



## Workshop Manual up! 2012 ➤

### Electrical system

Edition 03.2017





## List of Workshop Manual Repair Groups

### Repair Group

- 27 - Starter, current supply, CCS
- 90 - Gauges, instruments
- 92 - Windscreen wash/wipe system
- 94 - Lights, bulbs, switches - exterior
- 96 - Lights, bulbs, switches - interior
- 97 - Wiring

Technical information should always be available to the foremen and mechanics, because their careful and constant adherence to the instructions is essential to ensure vehicle road-worthiness and safety. In addition, the normal basic safety precautions for working on motor vehicles must, as a matter of course, be observed.

All rights reserved.  
No reproduction without prior agreement from publisher.



## Contents

<b>27 - Starter, current supply, CCS</b>	<b>1</b>
<b>1 Battery</b>	<b>1</b>
1.1 Assembly overview - battery	1
1.2 Removing and installing battery	3
1.3 Removing and installing earth wire with battery monitor control unit J367	4
1.4 Adapting battery monitor control unit J367	5
1.5 Disconnecting and connecting battery	5
1.6 Removing and installing battery tray	8
1.7 Checking battery	9
1.8 Charging battery	9
<b>2 Alternator</b>	<b>10</b>
2.1 Assembly overview - alternator	10
2.2 Removing and installing alternator	11
2.3 Checking alternator	14
2.4 Checking poly V-belt	14
2.5 Removing and installing poly V-belt pulley	14
2.6 Removing and installing voltage regulator	19
<b>3 Starter motor</b>	<b>24</b>
3.1 Assembly overview - starter	24
3.2 Removing and installing starter motor	25
3.3 Checking starter	27
<b>4 Cruise control system (CCS)</b>	<b>28</b>
<b>5 Start/stop system</b>	<b>29</b>
5.1 General description - start/stop system	29
5.2 Removing and installing voltage stabiliser	30
<b>90 - Gauges, instruments</b>	<b>31</b>
<b>1 Dash panel insert</b>	<b>31</b>
1.1 Assembly overview - dash panel insert	31
1.2 Removing and installing dash panel insert KX2	36
<b>2 Horn</b>	<b>38</b>
2.1 Assembly overview - horn	38
2.2 Removing and installing treble horn H2 and bass horn H7	39
<b>92 - Windscreen wash/wipe system</b>	<b>40</b>
<b>1 windscreen wiper system.</b>	<b>40</b>
1.1 Assembly overview - windscreen wiper system	40
1.2 Moving wipers to service position	41
1.3 Removing and installing wiper blade	41
1.4 Removing and installing wiper arms	42
1.5 Adjusting wiper arms	44
1.6 Renewing windscreen wiper rubber	46
1.7 Removing and installing wiper motor V	47
1.8 Renewing wiper motor	49
<b>2 Windscreen washer system</b>	<b>52</b>
2.1 Assembly overview - windscreen washer system	52
2.2 Removing and installing washer fluid reservoir	53
2.3 Removing and installing windscreen washer pump	54
2.4 Removing and installing spray jets	55
2.5 Adjusting spray jets	56
<b>3 Rear window wiper system</b>	<b>57</b>
3.1 Assembly overview - rear window wiper system	57



3.2	Removing and installing wiper blade	58
3.3	Removing and installing wiper arm	58
3.4	Adjusting wiper arm	59
3.5	Removing and installing rear window wiper motor V12	60
<b>4</b>	<b>Rear window washer system</b>	<b>61</b>
4.1	Assembly overview - rear window washer system	61
4.2	Removing and installing spray jet	61
4.3	Adjusting spray jet	62
<b>5</b>	<b>Washer fluid lines</b>	<b>63</b>
5.1	Repairing washer fluid lines	63
<b>94</b>	<b>Lights, bulbs, switches - exterior</b>	<b>64</b>
<b>1</b>	<b>Headlights</b>	<b>64</b>
1.1	Assembly overview - headlight	64
1.2	Removing and installing headlight	66
1.3	Adjusting headlights	67
1.4	Adjusting headlight installation position	67
1.5	Removing and installing front turn signal bulb M5 / M7	68
1.6	Installing repair kit for headlight housing	70
1.7	Converting headlights from driving on right to driving on left	73
1.8	Converting headlights from driving on left to driving on right	74
1.9	Removing and installing headlight range control motor V48 / V49	74
1.10	Removing and installing dipped beam bulb	75
1.11	Removing and installing bulb for daytime running light/side light	77
<b>2</b>	<b>Fog lights</b>	<b>79</b>
2.1	Assembly overview - fog lights	79
2.2	Removing and installing fog light	79
2.3	Removing and installing fog light bulb	80
2.4	Adjusting fog lights	81
<b>3</b>	<b>Turn signal repeater</b>	<b>82</b>
3.1	Removing and installing turn signal repeater	82
3.2	Removing and installing turn signal light bulb	83
<b>4</b>	<b>Tail lights</b>	<b>84</b>
4.1	Assembly overview - tail lights in body	84
4.2	Removing and installing bulb carrier	85
4.3	Removing and installing tail light bulb M2 / M4	85
4.4	Removing and installing tail light	86
4.5	Removing and installing rear fog light bulb L46 / L47	87
4.6	Removing and installing brake and tail light bulb M21 / M22	88
4.7	Removing and installing reversing light bulb	88
4.8	Removing and installing turn signal bulb	89
<b>5</b>	<b>High-level brake light</b>	<b>90</b>
5.1	Removing and installing additional brake light	90
<b>6</b>	<b>Number plate light</b>	<b>93</b>
6.1	Removing and installing number plate light X4 / X5	93
6.2	Removing and installing bulb for number plate light X4 / X5	93
<b>7</b>	<b>Steering column switch module</b>	<b>95</b>
7.1	Steering column switch module ► 10.2013	95
7.2	Steering column switch module 11.2013 ►	103
<b>8</b>	<b>Parking aid</b>	<b>115</b>
8.1	Assembly overview – parking aid	115
8.2	Removing and installing rear parking aid warning buzzer H15	115
8.3	Adapting volume and frequency of rear parking aid warning buzzer	116
8.4	Removing and installing rear parking aid senders	116



8.5	Removing and installing parking aid control unit J446	118
<b>9</b>	<b>Emergency braking function</b>	<b>120</b>
9.1	Removing and installing City Emergency Braking System	120
<b>96</b>	<b>Lights, bulbs, switches - interior</b>	<b>122</b>
<b>1</b>	<b>Lights</b>	<b>122</b>
1.1	Removing and installing front passenger airbag warning lamp	122
1.2	Removing and installing indicator lamp for central locking SAFELOCK function	122
1.3	Checking indicator lamp for central locking SAFELOCK function	122
1.4	Removing and installing front interior and reading light	123
1.5	Removing and installing bulbs for front interior and reading light	126
1.6	Removing and installing front reading lights	128
<b>2</b>	<b>Controls</b>	<b>130</b>
2.1	Removing and installing light switch	130
2.2	Removing and installing headlight range control regulator	131
2.3	Removing and installing switch module in middle of dash panel	131
2.4	Removing and installing start-stop operation button	132
2.5	Removing and installing hazard warning light switch	133
2.6	Removing and installing pushbutton for heated rear window	133
2.7	Removing and installing seat heater pushbutton	133
2.8	Removing and installing key-operated switch to deactivate front passenger side airbag	133
2.9	Removing and installing operating unit for window regulator in driver door E512	134
2.10	Removing and installing front window regulator switch	135
2.11	Removing and installing mirror adjustment switch E43 / E168	136
2.12	Removing and installing driver side interior locking button for central locking system	137
2.13	Removing and installing centre console switch module	138
2.14	Removing and installing pushbutton for emergency braking function	139
2.15	Removing and installing sliding sunroof adjustment regulator	139
<b>3</b>	<b>Immobiliser</b>	<b>140</b>
3.1	Removing and installing immobiliser control unit	140
3.2	Removing and installing immobiliser reader coil	141
<b>4</b>	<b>Cigarette lighter, socket</b>	<b>142</b>
4.1	Removing and installing cigarette lighter	142
4.2	Removing and installing 12 V socket	142
4.3	Removing and installing bulb for illuminating cigarette lighter	142
<b>97</b>	<b>Wiring</b>	<b>143</b>
<b>1</b>	<b>Relay carriers, fuse holders, electronics boxes</b>	<b>143</b>
1.1	Removing and installing electronics box (E-box)	143
1.2	Removing and installing relay and fuse holder in electronics box	145
1.3	Removing and installing relay and fuse holder behind dash panel on driver side	147
<b>2</b>	<b>Select Control units</b>	<b>153</b>
2.1	Removing and installing onboard supply control unit J519	153
2.2	Removing and installing data bus diagnostic interface J533	155
<b>3</b>	<b>Connectors</b>	<b>156</b>
3.1	Repairing electrical wiring harnesses and plug-in connections	156
<b>4</b>	<b>Vehicle diagnosis, testing and information systems</b>	<b>157</b>
4.1	Online system test	157





## 27 – Starter, current supply, CCS

### 1 Battery

(VRL010214; Edition 03.2017)

- ⇒ [“1.1 Assembly overview - battery”, page 1](#)
- ⇒ [“1.2 Removing and installing battery”, page 3](#)
- ⇒ [“1.4 Adapting battery monitor control unit J367”, page 5](#)
- ⇒ [“1.5 Disconnecting and connecting battery”, page 5](#)
- ⇒ [“1.6 Removing and installing battery tray”, page 8](#)
- ⇒ [“1.7 Checking battery”, page 9](#)
- ⇒ [“1.8 Charging battery”, page 9](#)

#### 1.1 Assembly overview - battery

##### Warning notices and safety regulations

All the instructions and information for this manual are found in the workshop manual “Electrical System, General Information”. A link to this workshop manual is not possible at present for technical reasons. Please select the workshop manual “Electrical System, General Information” manually in ELSA.

##### Battery terminal connection

All the instructions and information for this manual are found in the workshop manual “Electrical System, General Information”. A link to this workshop manual is not possible at present for technical reasons. Please select the workshop manual “Electrical System, General Information” manually in ELSA.



### 1 - Earth wire battery terminal clamp

- Comply with the instructions regarding threaded connections of the battery terminals  
⇒ [page 1](#)
- Depending on vehicle equipment, the battery monitor control unit - J367- may be installed instead.
- Removing and installing battery monitor control unit - J367-  
⇒ [page 4](#)
- Specified torque for nut securing wire to body: 20 Nm

### 2 - Securing nut for earth wire battery terminal clamp

- M6
- Specified torque: 6 Nm

### 3 - Earth wire cover

### 4 - electronics box with holder

- Removing and installing  
⇒ [page 143](#)
- Specified torque for nut securing electronics box to battery terminal clamp for positive cable: 6 Nm

### 5 - Positive wire battery terminal clamp

- Specified torque for nut securing electronics box to battery terminal clamp for positive cable: 6 Nm

### 6 - Securing nut for positive wire battery terminal clamp

- Comply with the instructions regarding threaded connections of the battery terminals ⇒ [page 1](#)
- M6
- Specified torque: 6 Nm

### 7 - Clamping plate securing nut

- M8
- Specified torque: 9 Nm

### 8 - Clamping plate

- Observe assembly note

### 9 - Battery

- In the case of vehicles with start/stop system, observe instructions for replacement of battery  
⇒ [page 3](#) .
- Removing and installing ⇒ [page 3](#)

### 10 - Nuts for securing battery tray

- M6
- Specified torque: 9 Nm

### 11 - Battery tray

- Removing and installing ⇒ [page 8](#)

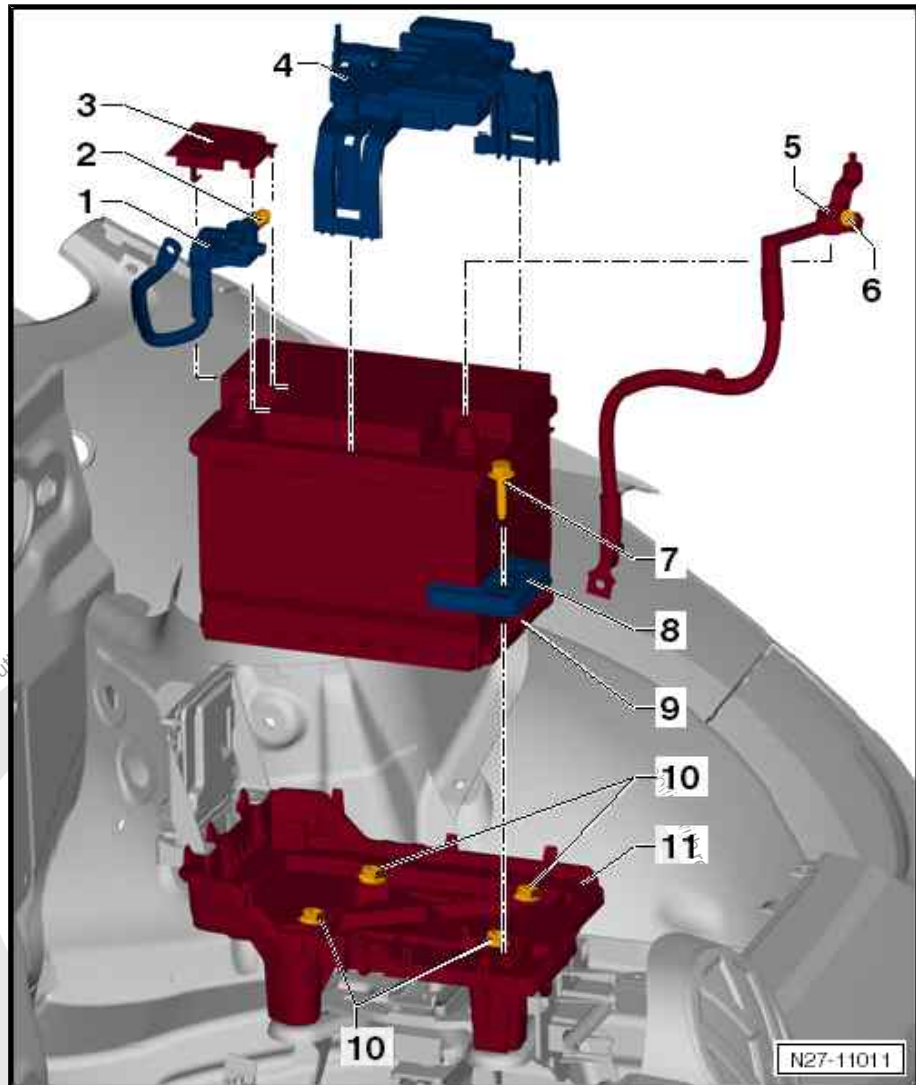





- ❑ Nuts for securing battery tray to body: 15 Nm
- ❑ Bolts for securing bracket of engine control unit to battery tray: 8 Nm

## 1.2 Removing and installing battery

### Special tools and workshop equipment required

- ◆ Torque wrench - V.A.G 1331-

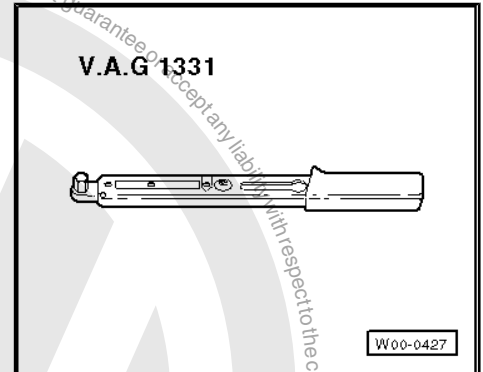

**WARNING**

*Risk of injury. Comply with the warning notices and safety regulations ⇒ [page 1](#).*

**Caution**

*To disconnect and reconnect the battery, the procedure described in the workshop manual should be strictly adhered to ⇒ [page 5](#).*

### Replacing battery on vehicles with start/stop system:

Because of its higher deep-cycle resistance, only a special starter battery is used in vehicles with a start/stop system.

When renewing the starter battery, note correct part designation in ⇒ ETKA (electronic parts catalogue). Starter batteries for use in vehicles with a start/stop system are marked with "AGM" (Absorbent Glass Mat) or "EFB" (Enhanced Flooded Battery).

### **i** Note

- ◆ *In vehicles with a battery sensor (start-stop system), the battery has to be parameterised after a new starter battery has been installed.*
- ◆ *The battery parameterisation sends the technical data of the new battery to the battery monitor.*
- ◆ *Performing battery parameterisation ⇒ [page 5](#).*

### Removing

- Disconnect battery ⇒ [page 5](#).



- Undo and remove bolt -1- and remove clamping plate -2-.
- Remove battery -4-.

### Installing



#### Caution

*A loosely fitted battery creates the following dangers:*

- ◆ *Shortened service life caused by vibration damage (danger of explosion).*
- ◆ *Damage to the grid plates of the battery.*
- ◆ *Damage to battery casing by clamping bracket (possible leakage of acid with high consequential costs).*
- ◆ *Poor crash safety.*

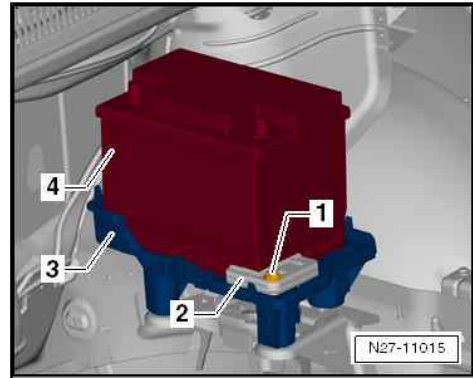

Install in the reverse order of removal, observing the following:

- Place battery -4- on battery tray -3- and push towards rear.
- Put clamping plate -2- on and secure with bolt -1-.
- Check battery is firmly seated after installation.
- Connect battery ⇒ [page 5](#) .



#### Note

- ◆ *In vehicles with a battery sensor (start-stop system), the battery has to be parameterised after a new starter battery has been installed.*
- ◆ *The battery parameterisation sends the technical data of the new battery to the battery monitor.*
- ◆ *Performing battery parameterisation ⇒ [page 5](#) .*

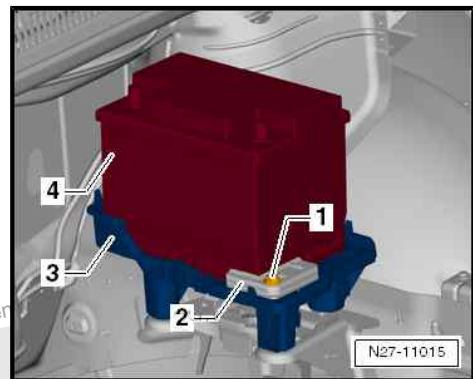

### Specified torques

- ◆ ⇒ ["1.1 Assembly overview - battery", page 1](#)

## 1.3 Removing and installing earth wire with battery monitor control unit - J367-

### Special tools and workshop equipment required

- ◆ Torque wrench - V.A.G 1331-

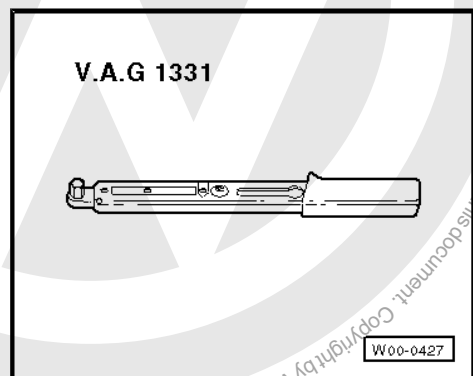



## Removing

- Separate electrical connector -2- on battery monitor control unit - J367- -3-.
- Remove battery - A- ⇒ [page 3](#) .
- Remove engine control unit ⇒ Rep. gr. 23 ; Engine control unit; Removing and installing engine control unit - J623- .

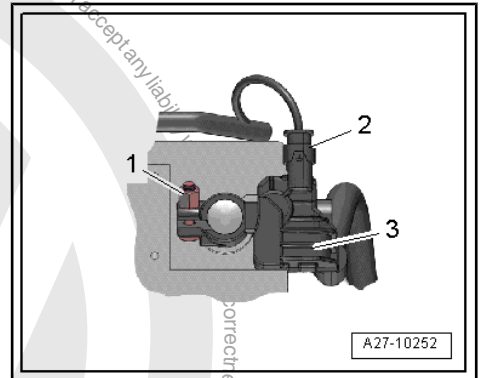

- Unscrew nut -1-.
- Remove earth wire with battery monitor control unit - J367- -2-.

## Installing

Install in the reverse order of removal, observing the following:

- Adapt battery monitor control unit - J367- ⇒ [page 5](#) .

## Specified torques

- ◆ ⇒ [“1.1 Assembly overview - battery”, page 1](#)

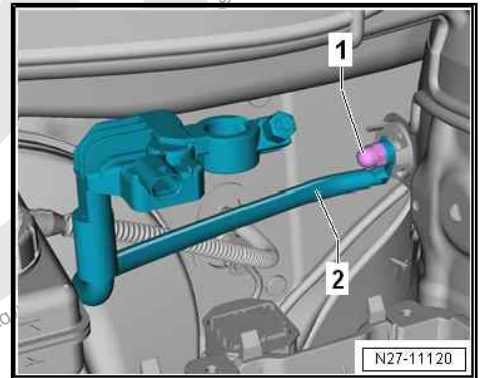

## 1.4 Adapting battery monitor control unit - J367-

After the installation of a new starter battery or a new battery monitor control unit - J367- , the battery monitor control unit - J367- must be adapted.

- Connect vehicle diagnostic tester ⇒ [page 157](#) .
- Adapt battery monitor control unit - J367- ⇒ Vehicle diagnostic tester.

## 1.5 Disconnecting and connecting battery

### Special tools and workshop equipment required

- ◆ Torque wrench - V.A.G 1331-

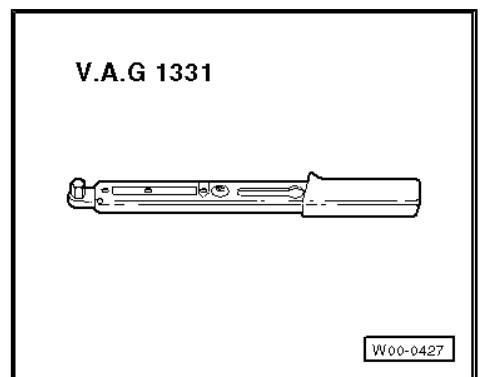

### Recharging battery or jump start on vehicles with start/stop system:

When recharging or jump starting vehicles with start/stop system, note the following: first connect charging cable to battery positive terminal then body earth. This ensures that the battery sensor is not bridged. The direct charging of the battery on the negative terminal clamp means that the battery sensor is shunted and the



battery data are not registered by the sensor while charging. The values concerning the battery state saved in the data bus diagnostic interface do not then correspond to the values of the charged battery.



### WARNING

*Risk of injury. Comply with the warning notices and safety regulations => [page 1](#).*

## Disconnecting battery



### Note

- ◆ *By disconnecting the battery earth wire (open circuit), safety is ensured when carrying out work on the electrical system.*
- ◆ *The battery positive wire need only be disconnected for removal of the battery.*
  
- Switch off ignition and all electrical consumers, and withdraw ignition key.
- Fold up cover (if fitted) of earth wire on battery terminal clamp.
- First, undo the nut of earth wire battery terminal clamp -1- and pull terminal clamp off battery negative terminal.
  
- Fold up cover of electronics box -1- and remove nut -2-.
- Release the catches -arrows- on each side of the electronics box holder and remove electronics Box together with holder upwards off the battery.

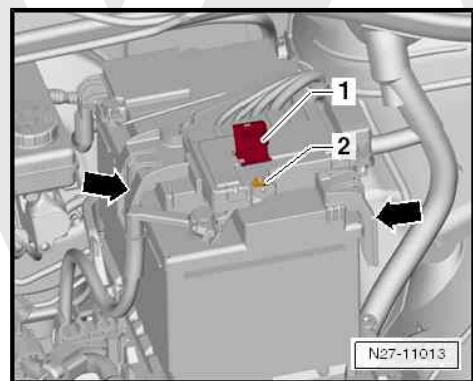
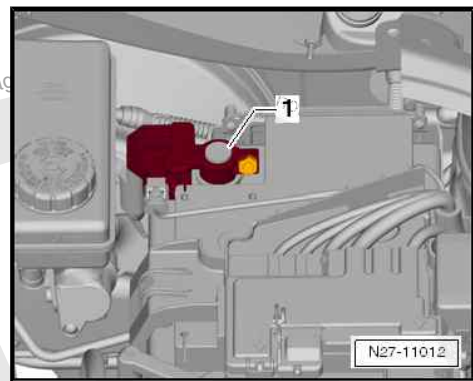



- Then undo the nut of battery terminal clamp for positive cable -1- and pull terminal clamp -2- off battery positive terminal.

### Connecting battery



#### Caution

Comply with instructions regarding threaded connections of the battery terminals ⇒ [page 1](#).

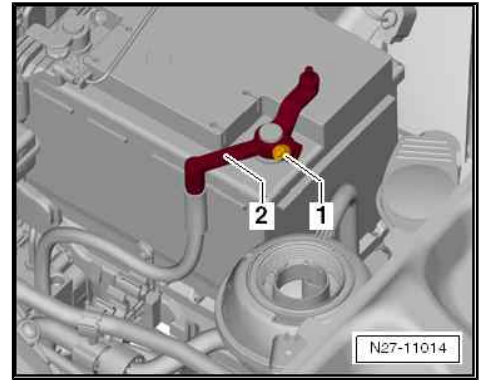

- Connect battery terminal clamp of positive cable -2- to positive terminal of battery. Tighten securing nut -1- to specified torque as per assembly overview ⇒ [page 1](#).

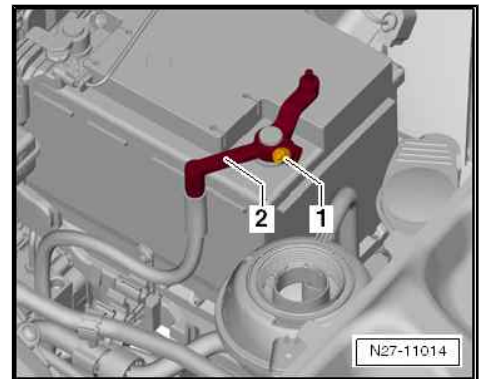

- Place electronics box together with holder onto battery and secure with latches -arrows-.
- Screw on nut -2- and tighten to torque prescribed in assembly overview ⇒ [page 1](#).
- Close cover -1- and secure with latch.

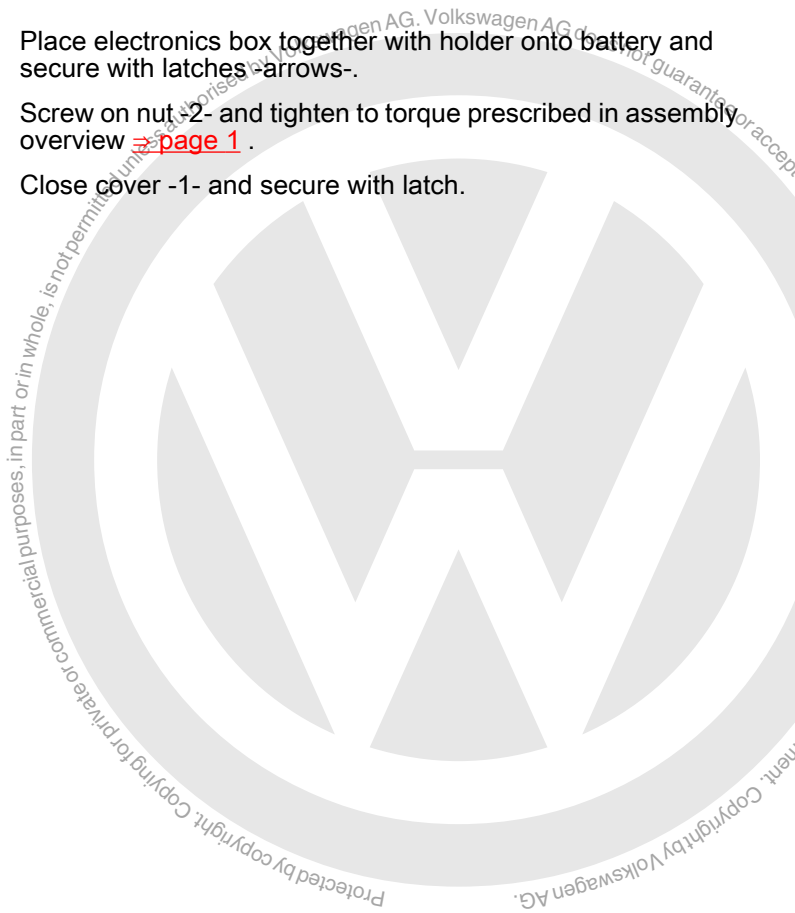
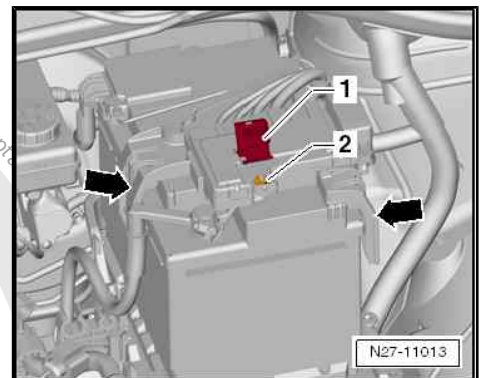



- Connect battery terminal clamp of earth wire -1- to negative terminal of battery.
- Tighten securing nut.
- Work through steps listed in table.

**Procedures after reconnecting battery:**

Procedure	Performed
Ignition with ignition key: switch on ignition and then switch off again.	
Read event memory: => Guided fault finding using VAS 5051A .	
Check time on clock and change as necessary.	
Open all electric windows fully and close again.	
Functional check: check all electrical consumers.	

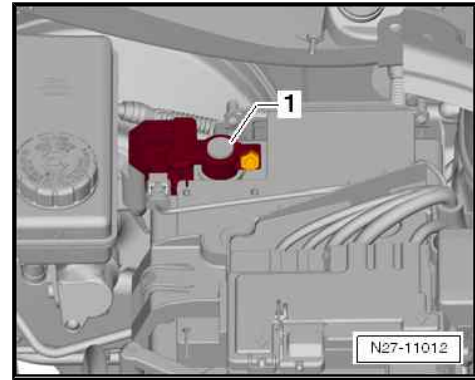

Table can be printed out if necessary.

**Specified torques**

- ◆ => ["1.1 Assembly overview - battery", page 1](#)

**1.6 Removing and installing battery tray**

**Special tools and workshop equipment required**

- ◆ Torque wrench - V.A.G 1331-

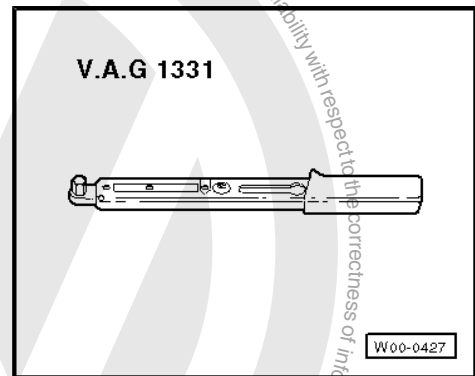

**Removing**

- Remove battery => [page 9](#)





- Unscrew securing nuts and bolts -2-.
- Release the two catches -3-, and pull refrigerant line holder -4- off battery tray.
- Unclip all lines from refrigerant line retainer -5-.
- Pull catch -6- at bottom of refrigerant line holder -5-, and pull holder upwards off battery tray.
- Lift battery tray -1-.

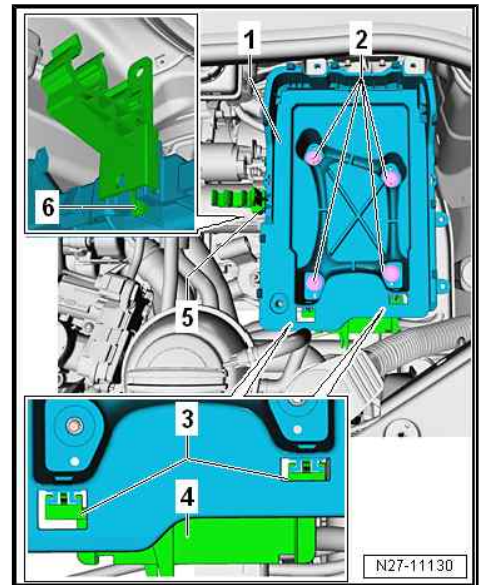

- Disconnect connectors from engine control unit. To do this, press catch -1- with a screwdriver in -direction of arrow-.
- Swing locking bar -2- in -direction of arrow-, and pull connector -3- off engine control unit.

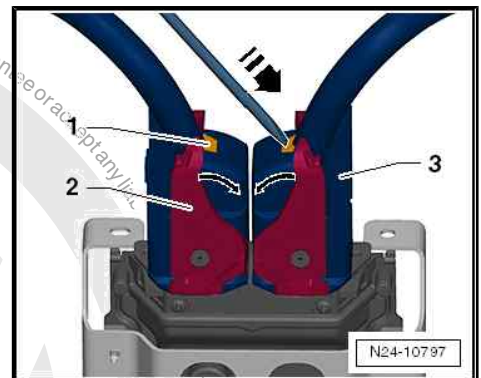

### Installing

Install in the reverse order of removal, observing the following:

### Specified torques

- ◆ => ["1.1 Assembly overview - battery", page 1](#)

## 1.7 Checking battery

Check battery => Electrical system, General information; Rep. gr. 27 ; Checking battery .

The battery - A- is monitored in the self-diagnosis function of the data bus diagnostic interface - J533- in "Guided Fault Finding" mode => Vehicle diagnostic tester.

## 1.8 Charging battery

Charging battery => Electrical System, General Information; Rep. gr. 27 ; Charging battery .



## 2 Alternator

⇒ [“2.1 Assembly overview - alternator”, page 10](#)

⇒ [“2.2 Removing and installing alternator”, page 11](#)

⇒ [“2.3 Checking alternator”, page 14](#)

⇒ [“2.4 Checking poly V-belt”, page 14](#)

⇒ [“2.5 Removing and installing poly V-belt pulley”, page 14](#)

⇒ [“2.6 Removing and installing voltage regulator”, page 19](#)

### 2.1 Assembly overview - alternator

#### 1 - Protective cap

#### 2 - Nut for securing battery positive cable

- ❑ Specified torque: 20 Nm
- ❑ Securing B+ cable on alternator

#### 3 - Securing bolts for protective cap

#### 4 - Alternator

- ❑ Removing and installing alternator ⇒ [page 11](#)
- ❑ Checking alternator ⇒ [page 14](#)
- ❑ Removing and installing poly V-belt pulley on alternator ⇒ [page 14](#)
- ❑ Removing and installing voltage regulator ⇒ [page 19](#)

#### 5 - Poly V-belt pulley

- ❑ Checking poly V-belt ⇒ [page 14](#)
- ❑ Specified torque: 65 Nm, without free-wheel on alternator
- ❑ Specified torque: 80 Nm, with freewheel on alternator

#### 6 - Hexagon head flange bolts

- ❑ M8
- ❑ Specified torque: 20 Nm

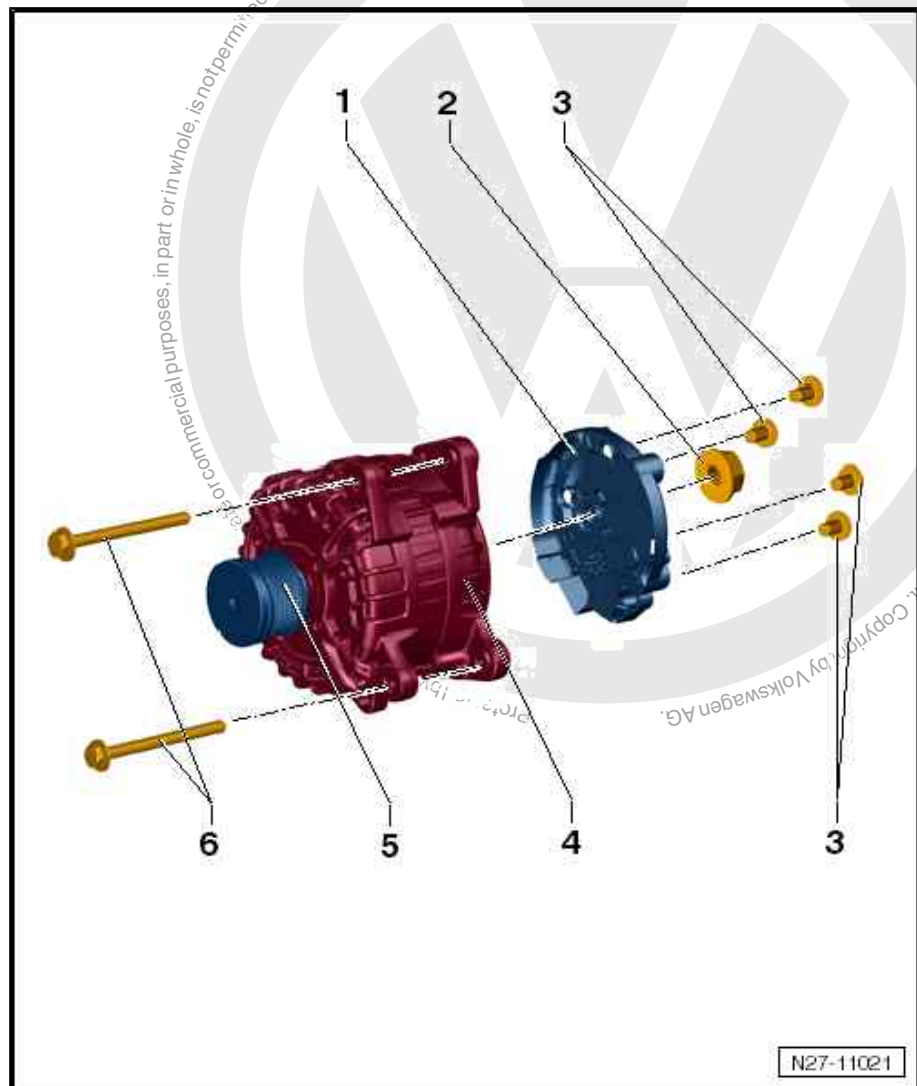

N27-11021





## 2.2 Removing and installing alternator

⇒ ["2.2.1 Removing and installing alternator, petrol engine", page 11](#)

⇒ ["2.2.2 Removing and installing alternator, natural gas engine", page 12](#)

### 2.2.1 Removing and installing alternator, petrol engine



#### Caution

*To disconnect and reconnect the battery, the procedure described in the workshop manual should be strictly adhered to ⇒ [page 5](#).*

#### Special tools and workshop equipment required

- ◆ Torque wrench - V.A.G 1331-

V.A.G 1331



W00-0427

#### Removing

- Disconnect battery ⇒ [page 5](#).
- Move lock carrier to service position ⇒ General body repairs, exterior; Rep. gr. 50 ; Lock carrier; Moving to and back from service position .
- Remove poly V-belt ⇒ Rep. gr. 13 ; Cylinder block, pulley end; Removing and installing poly V-belt .
- Unscrew the two securing bolts -arrows- of alternator - C- .
- Detach alternator - C- -1- and turn it over, taking into account the lengths of attached wires.

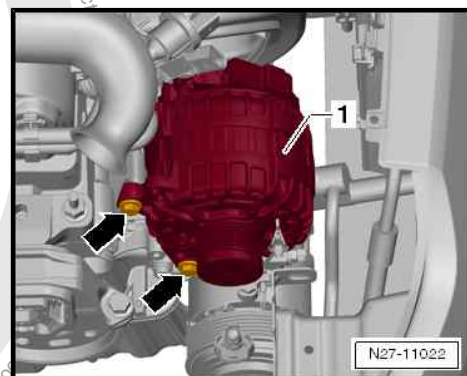

N27-11022



- Release and pull off DF cable connector -4-.
- Undo nut -3- and detach B+ wire -2- from connection thread.
- Remove alternator - C- -1- by taking it upwards out of vehicle.

### Installing

Install in the reverse order of removal observing the following:



#### Caution

- ◆ *When fitting used poly V-belts, take note of the direction of rotation as marked during removal!*
- ◆ *Before installing poly V-belt, ensure that all ancillaries (alternator, air conditioner compressor) are secure.*
- ◆ *When fitting belt, ensure that poly V-belt seats correctly in pulleys!*

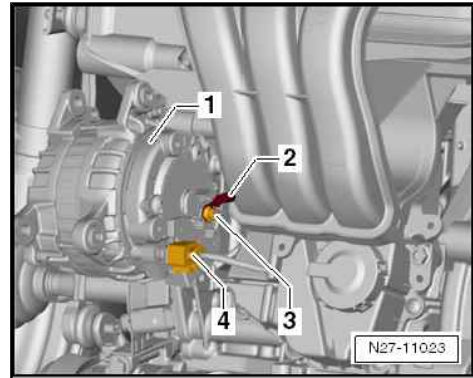

- Drive threaded bushes -A- approx. 4 mm in direction of arrow out of housing of alternator - C- .
- Connect battery ⇒ [page 5](#) .
- Start engine and check belt running.

### Specified torques

- ◆ ⇒ ["2.1 Assembly overview - alternator", page 10](#)

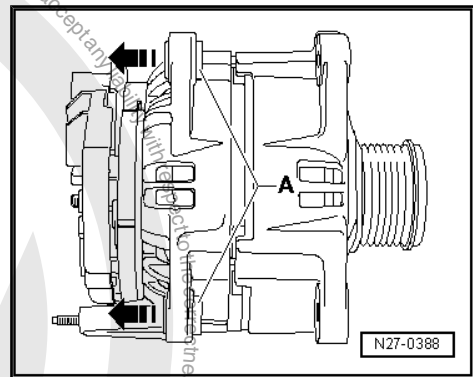

## 2.2.2 Removing and installing alternator, natural gas engine



#### Caution

*To disconnect and reconnect the battery, the procedure described in the workshop manual should be strictly adhered to ⇒ [page 5](#) .*

### Special tools and workshop equipment required

- ◆ Torque wrench - V.A.G 1331-

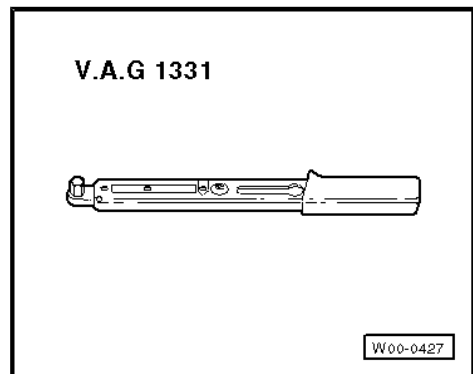

### Removing

- Disconnect battery ⇒ [page 5](#) .



- Move lock carrier to service position ⇒ General body repairs, exterior; Rep. gr. 50 ; Lock carrier; Moving to and back from service position .
- Remove poly V-belt ⇒ Rep. gr. 13 ; Cylinder block, pulley end; Removing and installing poly V-belt .
- Remove tensioner for poly V-belt ⇒ Rep. gr. 13 ; Cylinder block (pulley end); Removing and installing tensioner for poly V-belt .

#### Vehicles with air conditioning system

 **Caution**

**Risk of damage to air conditioner compressor, refrigerant lines and refrigerant hoses:**

◆ **Do NOT stretch, kink or bend refrigerant lines and hoses.**

- Remove air conditioner compressor from bracket ⇒ Heating, air conditioning system; Rep. gr. 87 ; Air conditioner compressor; Removing air conditioner compressor from and installing on bracket .
- Secure air conditioner compressor to lock carrier so that refrigerant lines are not under tension.

#### Continued for all vehicles

- Unscrew the two bolts -arrows- of alternator - C- .
- Detach alternator - C- -1- and turn it over, taking into account the lengths of attached wires.

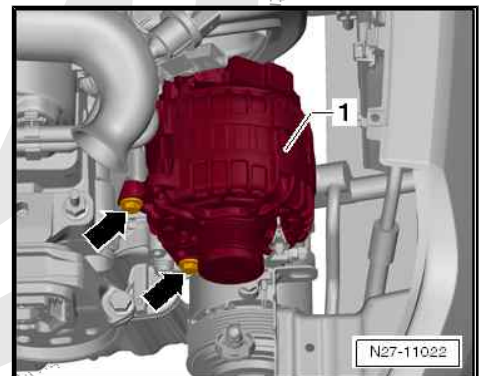

- Release and disconnect connector -4-.
- Unscrew securing nut -3-, and detach battery positive cable -2- from connection thread.
- Remove alternator - C- -1- by taking it downwards out of vehicle.

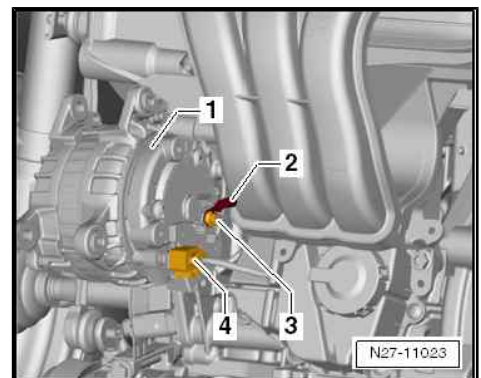

#### Installing

Install in the reverse order of removal observing the following:

 **Caution**

◆ **When fitting used poly V-belts, take note of the direction of rotation as marked during removal!**

◆ **Before installing poly V-belt, ensure that all ancillaries (alternator, air conditioner compressor) are secure.**

◆ **When fitting belt, ensure that poly V-belt seats correctly in pulleys!**



- Drive threaded bushes -A- approx. 4 mm in direction of arrow out of housing of alternator - C- .
- Connect battery ⇒ [page 5](#) .
- Start engine and check belt running.

#### Specified torques

- ◆ ⇒ ["2.1 Assembly overview - alternator", page 10](#)

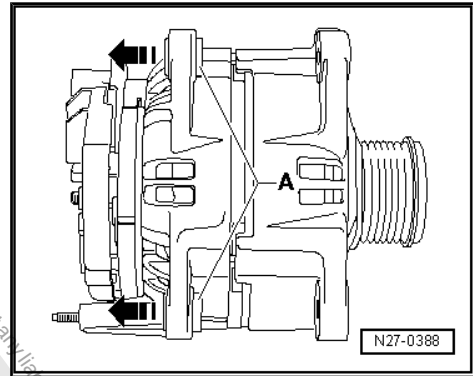

## 2.3 Checking alternator

- Connect vehicle diagnostic tester ⇒ [page 157](#) .
- Check alternator - C- ⇒ Vehicle diagnostic tester.

## 2.4 Checking poly V-belt

- Use a socket spanner to turn engine at vibration damper on pulley.
- Check poly V-belt for:
  - ◆ Sub-surface cracks (cracks, core ruptures, cross sectional breaks)
  - ◆ Layer separation (top layer, cord strands)
  - ◆ Base break-up
  - ◆ Frayed cord strands
  - ◆ Flank wear (material wear, frayed flanks, flank brittleness - glassy flanks-, surface cracks)
  - ◆ Traces of oil and grease



#### Caution

*In order to avoid failures and malfunctions, the poly V-belt must be replaced if it is damaged.*

## 2.5 Removing and installing poly V-belt pulley

⇒ ["2.5.1 Removing and installing poly V-belt pulley without free-wheel on alternator", page 14](#)

⇒ ["2.5.2 Removing and installing poly V-belt pulley, with free-wheel on alternator, Bosch", page 15](#)

⇒ ["2.5.3 Removing and installing poly V-belt pulley, with free-wheel on alternator, Valeo", page 17](#)

### 2.5.1 Removing and installing poly V-belt pulley without freewheel on alternator

Special tools and workshop equipment required



- ◆ Socket - VAS 3310-

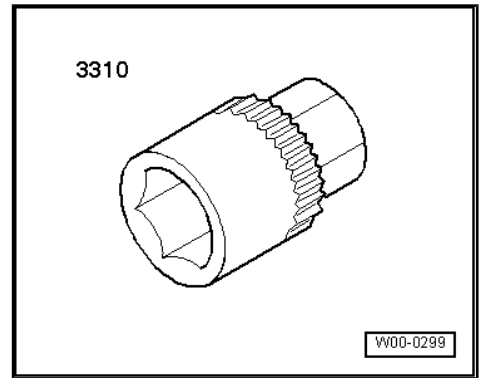

- ◆ Torque wrench - V.A.G 1332-

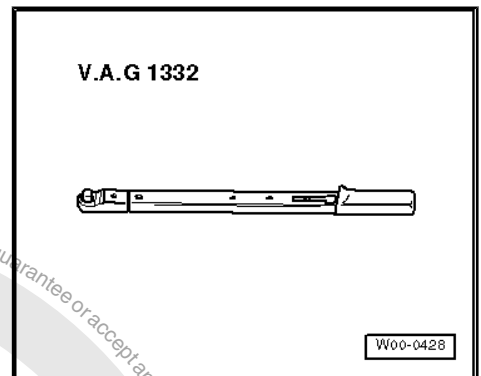

### Removing

- Remove alternator ⇒ [page 10](#) .
- Clamp alternator in a vice at securing points.
- Use socket - VAS 3310- to unscrew poly V-belt pulley securing nut from alternator shaft.

### Installing

Install in the reverse order of removal, observing the following:

### Specified torques

- ◆ ⇒ [“2.1 Assembly overview - alternator”, page 10](#)

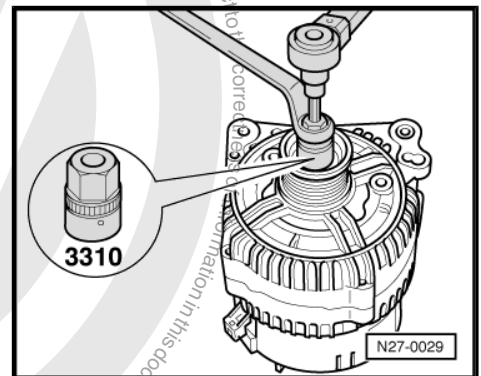

## 2.5.2 Removing and installing poly V-belt pulley, with freewheel on alternator, Bosch

Special tools and workshop equipment required



◆ Multipoint adapter - T10474-

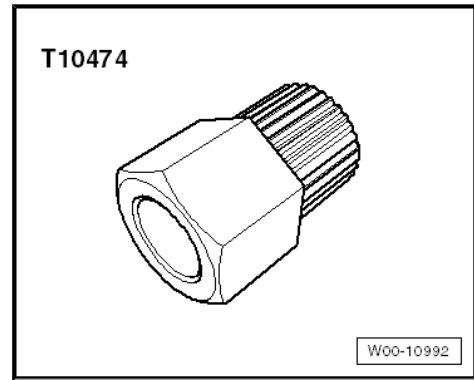

◆ Torque wrench - V.A.G 1332-

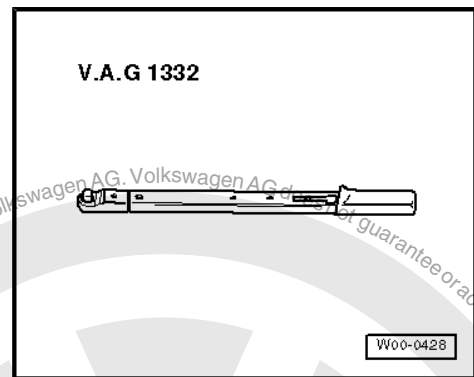

◆ Socket drive with 8 mm hexagon socket or TORX T50

**Removing**

- Remove alternator ⇒ [page 10](#) .
- Clamp alternator in a vice at securing points.
- Remove protective cap (where there is one) from poly V-belt pulley with freewheel.
- Insert multipoint adapter - T10474- -1- into poly V-belt pulley and fit an open-end spanner (width across flats 17 mm) to it.
- Insert hexagon socket or TORX socket -2- into alternator shaft.
- Turn generator shaft clockwise (left-handed thread) to loosen it, counterholding it with the open-end spanner.
- Hold poly V-belt pulley with freewheel stationary with your hand and turn alternator shaft until poly V-belt pulley with freewheel can be removed.

**Installing**

Install in the reverse order of removal observing the following:

The torque wrench - V.A.G 1332- must be modified for assembly of poly V-belt with freewheel as follows:

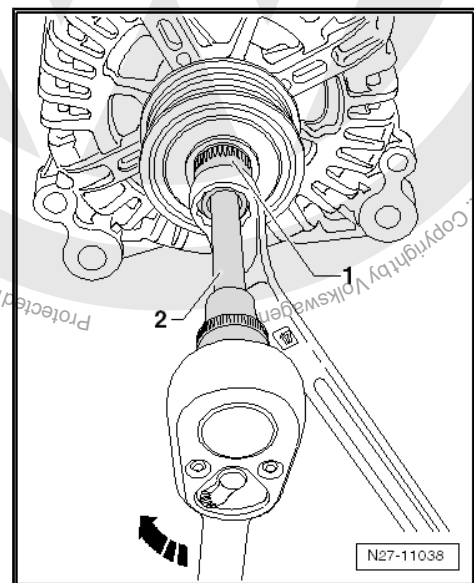





- Release socket drive -1- and pull off grip -2-.
- Turn torque wrench grip -2- 180° and reinsert socket drive.
- Set turning direction of torque wrench to anti-clockwise at socket drive.
- First screw poly V-belt pulley with freewheel onto alternator shaft by hand as far as possible.
- Insert multipoint adapter - T10474- -1- into poly V-belt pulley and fit an open-end spanner (width across flats 17 mm) to it.
- Insert hexagon socket or TORX socket -2- into alternator shaft.
- Turn alternator shaft anti-clockwise using torque wrench - V.A.G 1332- -3- in order to tighten poly V-belt pulley with freewheel.

**Specified torques**

- ◆ ⇒ [“2.1 Assembly overview - alternator”, page 10](#)

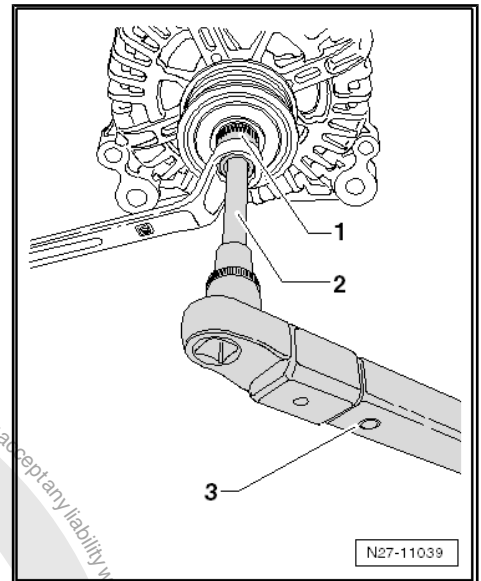
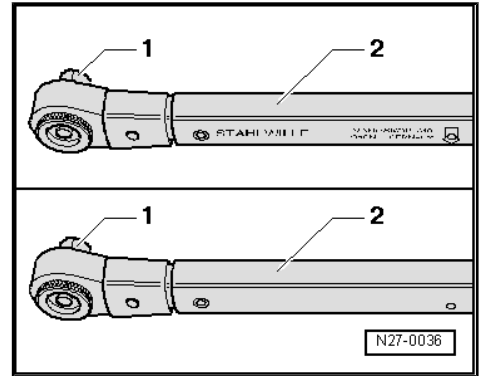

**2.5.3 Removing and installing poly V-belt pulley, with freewheel on alternator, Valeo**

**Special tools and workshop equipment required**

- ◆ Multipoint adapter - T10474-

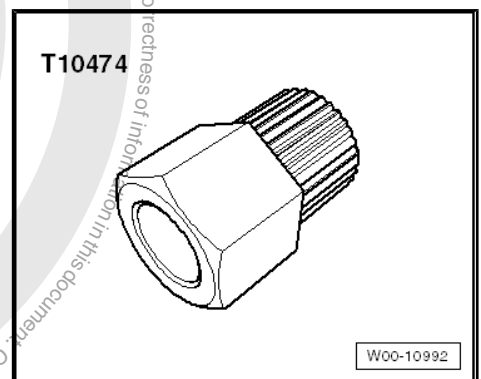

Protected by copyright. Copying for private or commercial purposes, in part or in whole, is not permitted unless authorised by Volkswagen AG. Volkswagen AG does not guarantee or accept any liability with respect to the correctness of information in this document.



◆ Torque wrench - V.A.G 1332-

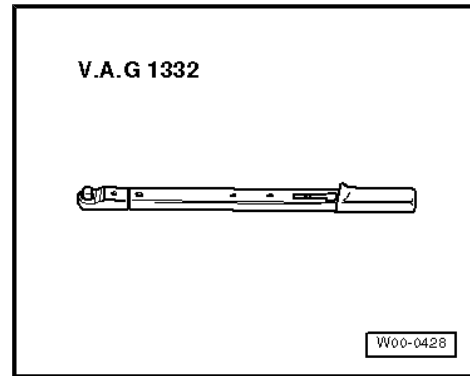

◆ Socket drive with 8 mm hexagon socket or TORX T50

**Removing**

- Remove alternator ⇒ [page 10](#) .
- Clamp alternator in a vice at securing points.
- Remove protective cap (where there is one) from poly V-belt pulley with freewheel.
- Insert multipoint adapter - T10474- -1- into poly V-belt pulley and fit an open-end spanner (width across flats 17 mm) to it.
- Insert hexagon socket or TORX socket -2- into alternator shaft.
- Turn generator shaft clockwise (left-handed thread) to loosen it, counterholding it with the open-end spanner.
- Hold poly V-belt pulley with freewheel stationary with your hand and turn alternator shaft until poly V-belt pulley with freewheel can be removed.

**Installing**

Install in the reverse order of removal observing the following:

The torque wrench - V.A.G 1332- must be modified for assembly of poly V-belt with freewheel as follows:

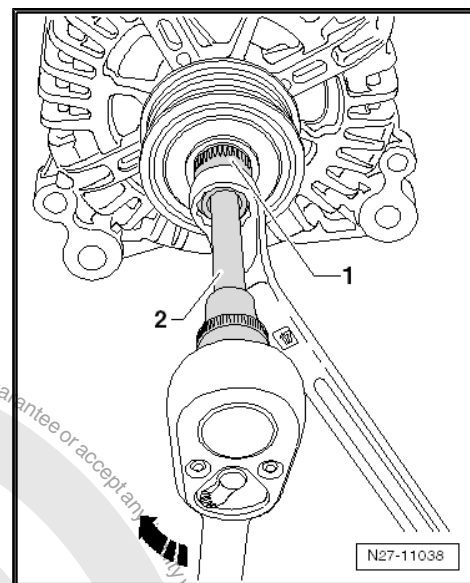

- Release socket drive -1- and pull off grip -2-.
- Turn torque wrench grip -2- 180° and reinsert socket drive.
- Set turning direction of torque wrench to anti-clockwise at socket drive.
- First screw poly V-belt pulley with freewheel onto alternator shaft by hand as far as possible.
- Insert multipoint adapter - T10474- -1- into poly V-belt pulley and fit an open-end spanner (width across flats 17 mm) to it.

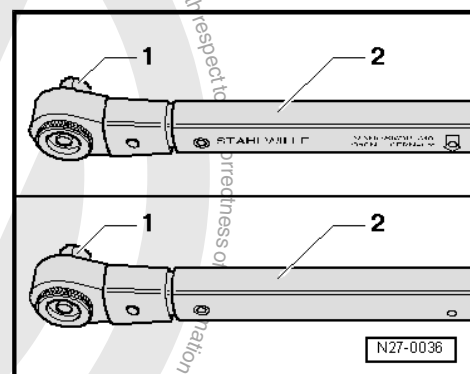





- Insert hexagon socket or TORX socket -2- into alternator shaft.
- Turn alternator shaft anti-clockwise using torque wrench - V.A.G 1332- -3- in order to tighten poly V-belt pulley with freewheel.

#### Specified torques

- ◆ ⇒ ["2.1 Assembly overview - alternator", page 10](#)

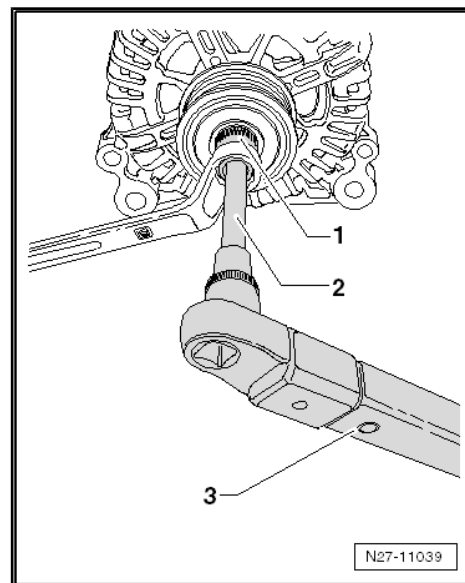

## 2.6 Removing and installing voltage regulator

⇒ ["2.6.1 Removing and installing voltage regulator, Bosch, version 1", page 19](#)

⇒ ["2.6.2 Removing and installing voltage regulator, Bosch, version 2", page 20](#)

⇒ ["2.6.3 Removing and installing voltage regulator, Valeo", page 21](#)

### 2.6.1 Removing and installing voltage regulator, Bosch, version 1

#### Special tools and workshop equipment required

- ◆ Torque screwdriver - V.A.G 1624-

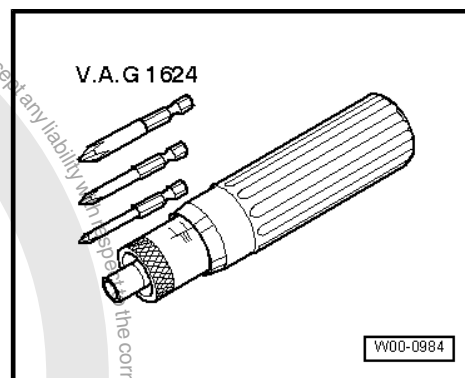

#### Removing

- Remove alternator ⇒ [page 11](#) .



- Remove securing bolt and nuts -arrows- and remove deflector cap from alternator.

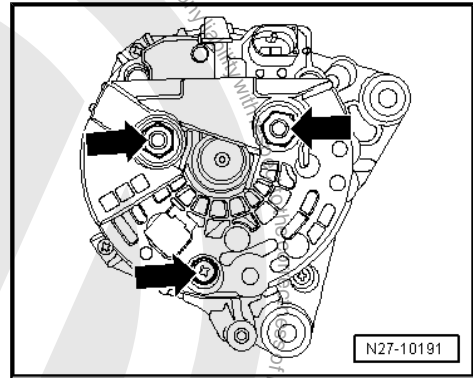

- Unscrew securing bolts of voltage regulator -arrows-.
- Remove voltage regulator from alternator.

### Installing

Install in the reverse order of removal observing the following:

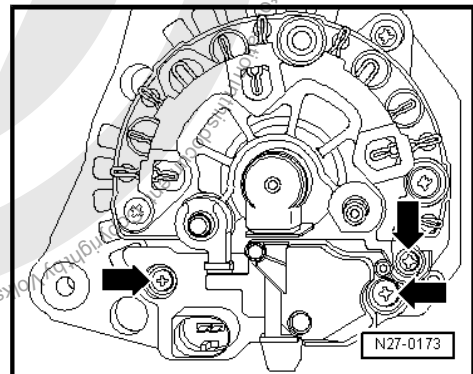

### Specified torques

Component	Specified torque
M5 securing bolt securing protective cap to alternator	4.5 Nm
M4 securing bolt securing voltage regulator to alternator	2 Nm

## 2.6.2 Removing and installing voltage regulator, Bosch, version 2

### Special tools and workshop equipment required

- ◆ Offset screwdriver for slotted screws - VAS 6416-

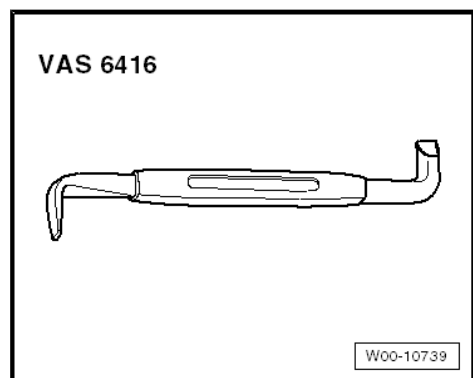



- ◆ Torque screwdriver - V.A.G 1624-

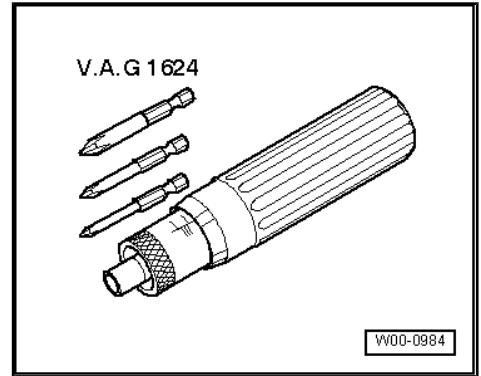

### Removing

- Remove alternator - C- → [page 11](#) .
- Using offset screwdriver for slotted-head screws - VAS 6416- , carefully lever off protective cap -1- at fasteners -arrows-.

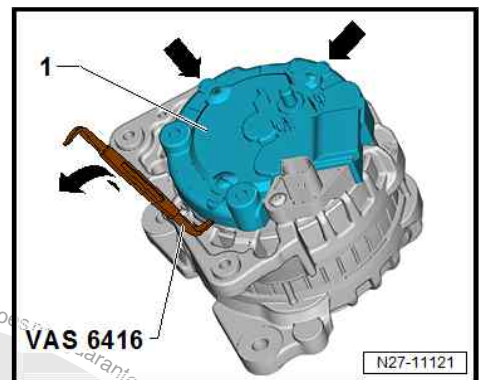

- Unscrew securing bolts -arrows- for voltage regulator - C1- .
- Detach voltage regulator - C1- from alternator - C- .

### Installing

Install in the reverse order of removal observing the following:

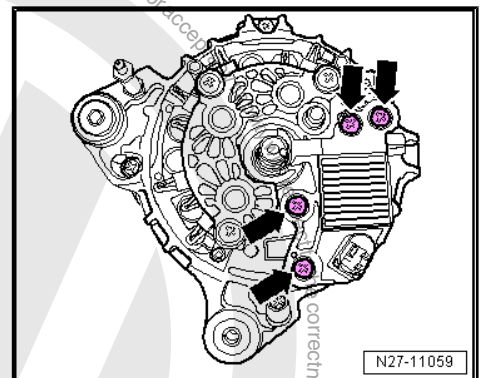

### Specified torques

Component	Specified torque
M4 securing bolt securing voltage regulator to alternator	2 Nm

## 2.6.3 Removing and installing voltage regulator, Valeo

### Special tools and workshop equipment required



- ◆ Torque wrench - V.A.G 1783/-

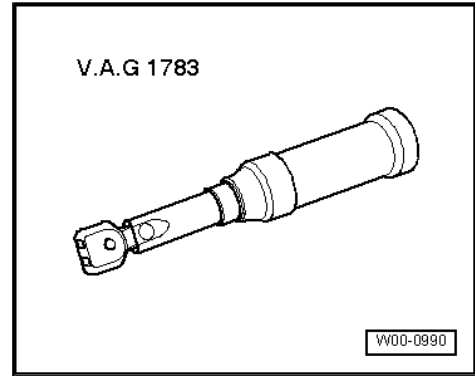

### Removing

- Remove alternator ⇒ [page 11](#) .
- Remove clamping rings -arrows- and remove protective cap from alternator.

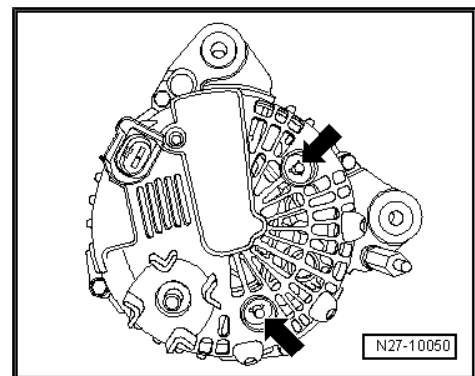

- Unscrew securing bolts of voltage regulator -arrows-.
- Remove voltage regulator from alternator.

### Installing

Install in the reverse order of removal observing the following:

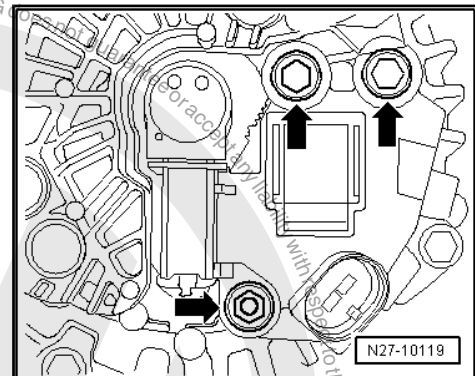

- Remove locking lugs -arrows- and pull protective cap off voltage regulator.
- Push carbon brushes into housing of voltage regulator and insert voltage regulator into alternator.
- Tighten threaded connections to specified torques.

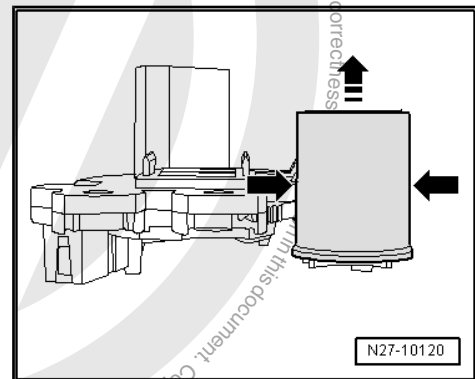



- Push protective cap into guides -arrows- until it can be heard to engage.

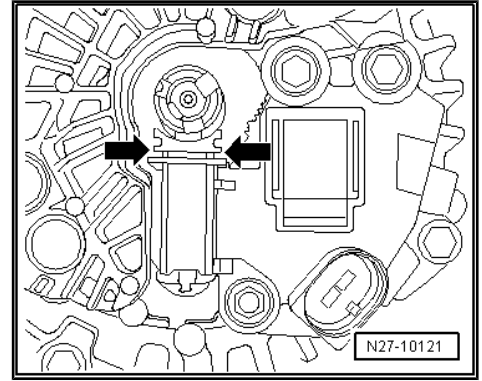

### Specified torques

Component	Specified torque
Voltage regulator to alternator	2 Nm
Protective cap to alternator	4.5 Nm





### 3 Starter motor

⇒ "3.1 Assembly overview - starter", page 24

⇒ "3.2 Removing and installing starter motor", page 25

⇒ "3.3 Checking starter", page 27

#### 3.1 Assembly overview - starter

##### 1 - Starter motor

- Removing and installing  
⇒ page 25
- Checking ⇒ page 27

##### 2 - Battery positive wire connection to starter

##### 3 - Battery positive wire securing nut to starter

- M8
- Specified torque: 15 Nm

##### 4 - Protective cap

##### 5 - Starter securing bolts

- M10 x 55
- Specified torque: 40 Nm

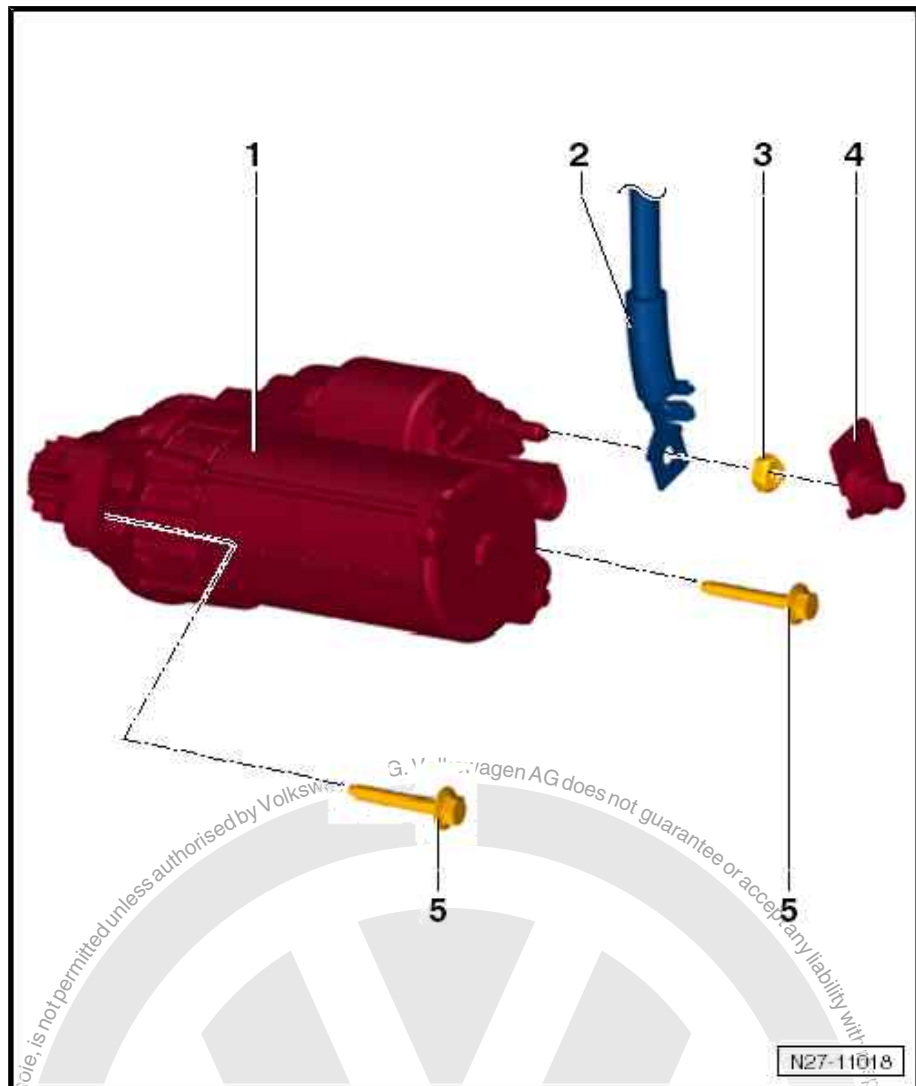



## 3.2 Removing and installing starter motor

⇒ ["3.2.1 Removing and installing starter, manual gearbox", page 25](#)

⇒ ["3.2.2 Removing and installing starter, automated manual gearbox", page 26](#)

### 3.2.1 Removing and installing starter, manual gearbox

#### Renewing starter on vehicles with start/stop system:

Due to the higher requirements on the starter when the start/stop system is activated, e.g. in urban traffic/driving, the deep-cycle resistance has been increased and the ring gear reinforced.

When renewing starter, make sure the new one with the correct part designation as shown in ⇒ Electronic parts catalogue (ETKA) is used. Components adapted to start/stop system are not identified separately and are not or barely different from normal components in their appearance.

#### Special tools and workshop equipment required

- ◆ Torque wrench - V.A.G 1331-

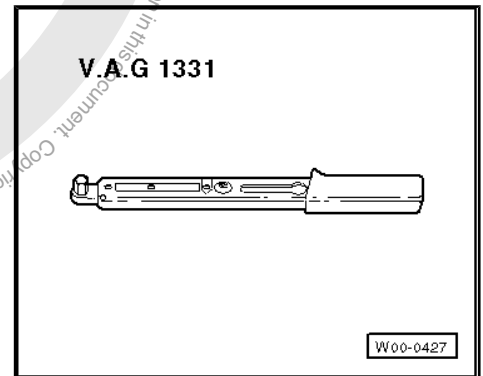

#### Removing

- Remove battery tray ⇒ [page 8](#) .
- Unclip gear selector cables from gearbox ⇒ Rep. gr. 34 ; Selector mechanism; Overview - selector mechanism .
- Lever off cover -2- and undo nut beneath it.
- Detach B+ wire -1- from connection thread.
- Release and disconnect connector -3-.

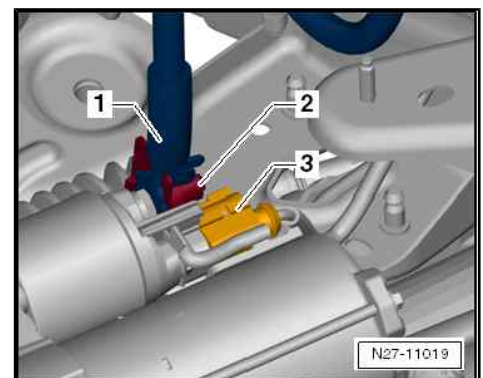



- Unscrew starter securing bolts -2-.
- Remove starter -1- by taking it upwards out of the vehicle.

### Installing

Install in the reverse order of removal observing the following:

### Specified torques

- ◆ ⇒ ["3.1 Assembly overview - starter", page 24](#)

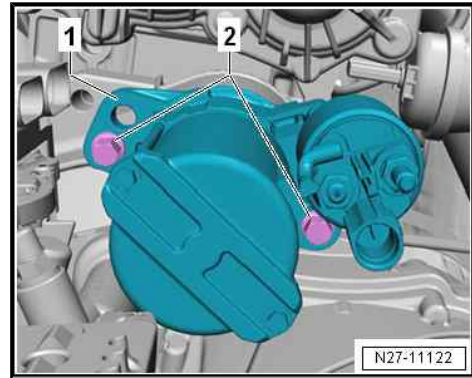

## 3.2.2 Removing and installing starter, automated manual gearbox

### Renewing starter on vehicles with start/stop system:

Due to the higher requirements on the starter when the start/stop system is activated, e.g. in urban traffic/driving, the deep-cycle resistance has been increased and the ring gear reinforced.

When renewing starter, make sure the new one with the correct part designation as shown in ⇒ [Electronic parts catalogue \(ETKA\)](#) is used. Components adapted to start/stop system are not identified separately and are not or barely different from normal components in their appearance.

### Special tools and workshop equipment required

- ◆ Torque wrench - V.A.G 1331-

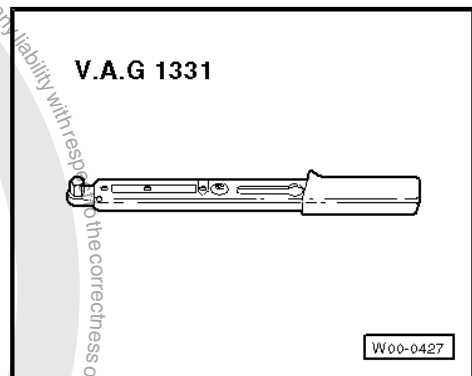

### Removing

- Remove battery tray ⇒ [page 8](#) .
- Lever off cover -2- and undo nut beneath it.
- Detach B+ wire -1- from connection thread.
- Release and disconnect connector -3-.

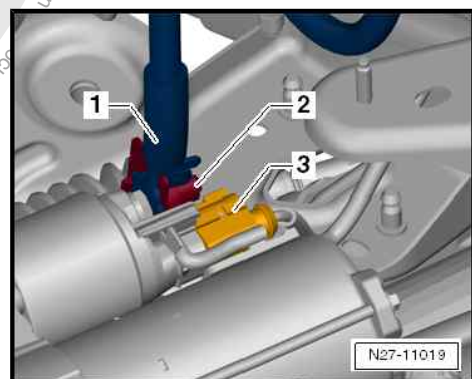





- Unscrew starter securing bolts -2-.
- Remove starter -1- by taking it upwards out of the vehicle.

### Installing

Install in the reverse order of removal observing the following:

### Specified torques

- ◆ ⇒ ["3.1 Assembly overview - starter", page 24](#)

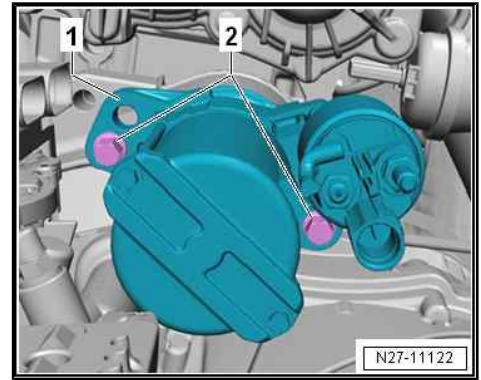

## 3.3 Checking starter

- Connect vehicle diagnostic tester ⇒ [page 157](#) .
- Check starter ⇒ Vehicle diagnostic tester.





## 4 Cruise control system (CCS)

All the instructions and information for this manual are found in the workshop manual "Electrical System, General Information". A link to this workshop manual is not possible at present for technical reasons. Please select the workshop manual "Electrical System, General Information" manually in ELSA.



## 5 Start/stop system

⇒ **“5.1 General description - start/stop system”, page 29**

⇒ **“5.2 Removing and installing voltage stabiliser”, page 30**

### 5.1 General description - start/stop system

#### General description:

The start/stop system is used for reducing fuel consumption by automatically switching off the engine when the vehicle is stationary and automatically starting it when the driver wants the vehicle to move on. The start/stop mode is automatically activated when, after starting to move, the vehicle is driven for about 4 seconds at a minimum speed of 3 km/h.

Following control units are involved in the start/stop system:

- ◆ Data bus diagnostic interface - J533- in the onboard power supply control unit - J519-
- ◆ Engine control unit - J623-
- ◆ ABS control unit - J104-

#### Recharging battery or jump start on vehicles with start/stop system:

When recharging or jump starting vehicles with start/stop system, note the following: first connect charging cable to battery positive terminal then body earth. This ensures that the battery sensor is not bridged. The direct charging of the battery on the negative terminal clamp means that the battery sensor is shunted and the battery data are not registered by the sensor while charging. Then, the values concerning the battery state and saved in the data bus diagnostic interface would not correspond to the values of the charged battery.

#### Replacing battery on vehicles with start/stop system:

Because of its higher deep-cycle resistance, only a special starter battery is used in vehicles with a start/stop system.

When renewing the starter battery, note correct part designation in ⇒ ETKA (electronic parts catalogue) . Starter batteries for use in vehicles with a start/stop system are marked with “AGM” (Absorbent Glass Mat) or “EFB” (Enhanced Flooded Battery).

#### Fault detection and fault display:

The start/stop system as a function is integrated in the engine control unit - J623- software.

The engine control unit - J623- features self-diagnosis to facilitate fault finding.

To localise faults, refer to chapter entitled “Vehicle diagnosis, testing and information system” and use “Guided fault finding” function.

The voltage stabiliser - J532- is secured on the floor covering under the left front seat. It has the task of stabilizing to 12 volts the high voltage fluctuations generated in the onboard supply by the start/stop operation.

#### Effects in case of voltage stabiliser failure:

If the voltage stabiliser is defective, devices such as the radio, radio navigation or telephone will perform a reset if their own voltage supply is not sufficient when the starter is operated. If, in start/stop mode, the mentioned electrical consumers are identified as causing a reset for each motor start, this indicates a defective voltage stabiliser. At present, no direct entries can be made concerning malfunction of the voltage stabiliser, e.g. in the event



memory of the diagnostic interface or in the onboard supply control unit. If radio, radio/navigation and telephone units have failed together, first check fuse of voltage stabiliser.

## 5.2 Removing and installing voltage stabiliser

### Removing

- Push driver's seat as far back as possible.
- Detach Velcro strip of voltage stabiliser - J532- -1- from floor covering.
- Release and pull off connector -2- and remove voltage stabiliser - J532- from vehicle.

### Installing

Install in the reverse order of removal observing the following:

- During installation, first attach and lock the connector, and then attach the stabiliser in its original position on the floor covering by means of the Velcro strip.

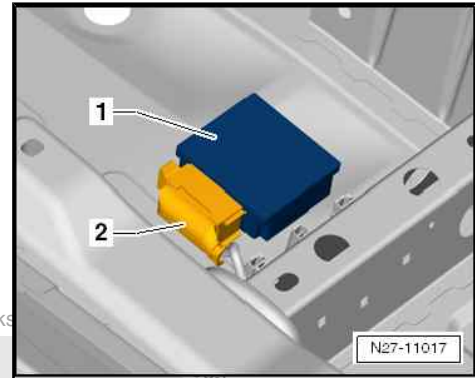



## 90 – Gauges, instruments

### 1 Dash panel insert

⇒ [“1.1 Assembly overview - dash panel insert”, page 31](#)

⇒ [“1.2 Removing and installing dash panel insert KX2 ”, page 36](#)

#### 1.1 Assembly overview - dash panel insert

⇒ [“1.1.1 Assembly overview - dash panel insert, indicator lamps, petrol engine”, page 31](#)

⇒ [“1.1.2 Assembly overview - dash panel insert, indicator lamps, natural gas engine”, page 34](#)

⇒ [“1.1.3 Assembly overview - dash panel insert, rear”, page 36](#)

##### 1.1.1 Assembly overview - dash panel insert, indicator lamps, petrol engine



#### Note

*Depending on the equipment, different dash panel inserts are used and, as a result, the arrangement of the indicator lamps can deviate from the illustration.*





**1 - Indicator lamp for left turn signal**

- Switched on

**2 - Electronic stabilisation programme (ESP) warning lamp**

- Flashes: electronic stabilisation programme (ESP) regulating
- Lights up: ESP fault or ESP switched off

**3 - Anti-lock brake system (ABS) warning lamp**

- Fault

**4 - Warning lamp for airbag system and belt tensioner**

- Airbag and/or belt tensioner defective

**5 - Seat belt warning lamp**

- Fasten seat belts!

**6 - Indicator lamp for tyre pressure monitor**

- Pressure of one particular tyre too low or sys-

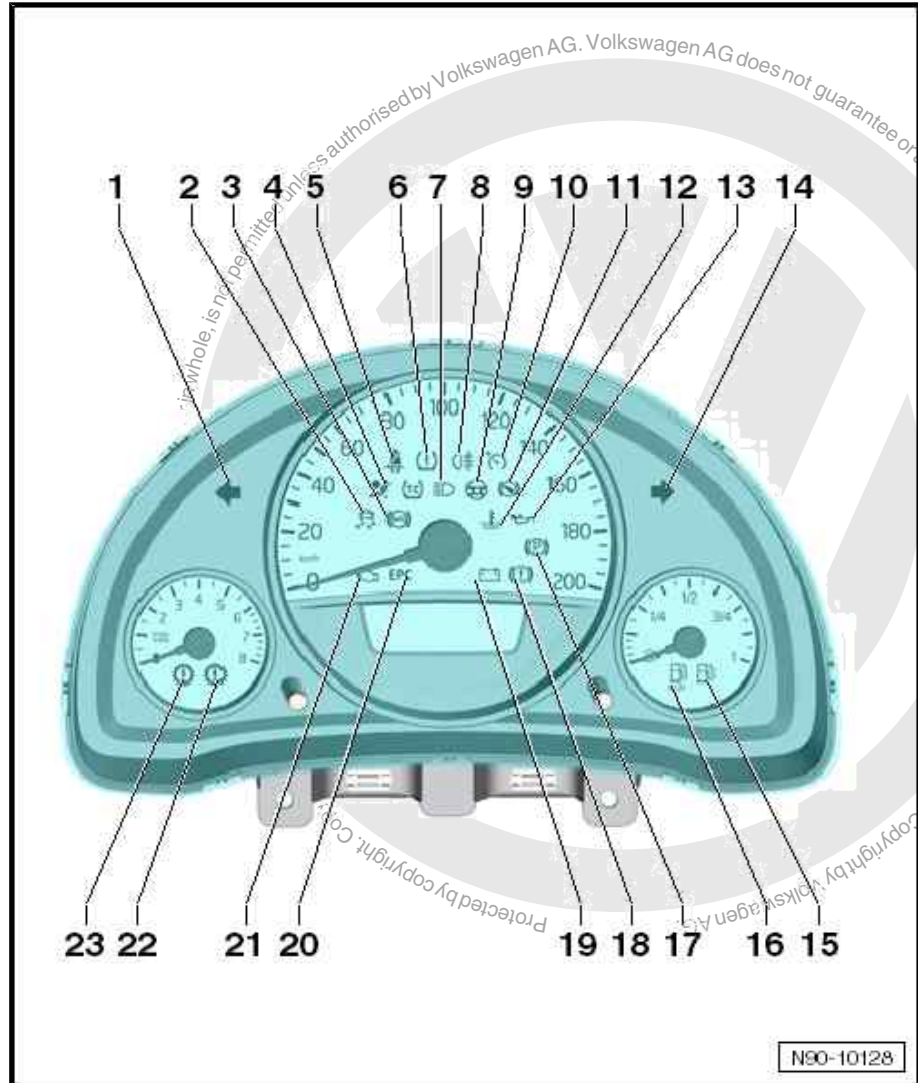



tem fault occurred

**7 - Main beam warning lamp**

- Switched on

**8 - Rear fog light warning lamp**

- Switched on

**9 - Indicator lamp for electro-mechanical power steering (EPS = Electronic Power Steering)**

- Lights up yellow: reduced electromechanical power steering
- Lights up red: eletromechanical power steering failure

**10 - Cruise control system (CCS) warning lamp**

- CCS regulating

**11 - Indicator lamp for "Operate foot brake"**

- Request from automated manual gearbox (SQ)
- Indicator lamp only fitted in vehicles with automated manual gearbox

**12 - Coolant temperature warning lamp**

- Coolant temperature too high or
- Engine coolant level too low

**13 - Oil pressure warning lamp**

- Oil pressure too low
- Switch off engine and check oil level

**14 - Indicator lamp for right turn signal**

- Switched on

**15 - Fuel level warning lamp**

- Fuel level too low (reserve)

**16 - Indicator lamp for natural gas level**

- Indicator lamp only fitted in natural gas vehicles
- Fuel level too low (reserve)

**17 - Parking brake indicator lamp**

- Parking brake applied

**18 - Brake system warning lamp**

- Lights up: fault in brake system
- Lights up: brake fluid low - stop engine, and check brake fluid level

**19 - Alternator warning lamp**

- Fault in alternator

**20 - Indicator lamp for engine fault EPC (electric throttle)**

- Fault

**21 - Indicator lamp for Electric On Board Diagnosis (EOBD)**

- Fault in exhaust system

**22 - Indicator lamp for fault in automated manual gearbox (red)**

- Indicator lamp only fitted in vehicles with automated manual gearbox

**23 - Indicator lamp for fault in automated manual gearbox (yellow)**

- Indicator lamp only fitted in vehicles with automated manual gearbox





## 1.1.2 Assembly overview - dash panel insert, indicator lamps, natural gas engine

### 1 - Indicator lamp for left turn signal

- Switched on

### 2 - Electronic stabilisation programme (ESP) warning lamp

- Flashes: electronic stabilisation programme (ESP) regulating
- Lights up: ESP fault or ESP switched off

### 3 - Anti-lock brake system (ABS) warning lamp

- Fault

### 4 - Warning lamp for airbag system and belt tensioner

- Airbag and/or belt tensioner defective

### 5 - Seat belt warning lamp

- Fasten seat belts!

### 6 - Indicator lamp for traction control

- Flashes: regulating
- Lights up: faulty or switched off by system

### 7 - Indicator lamp for tyre pressure monitor

- Pressure of one particular tyre too low or system fault occurred

### 8 - Main beam warning lamp

- Switched on

### 9 - Rear fog light warning lamp

- Switched on

### 10 - Indicator lamp for electromechanical power steering (EPS = Electronic Power Steering)

- Lights up yellow: reduced electromechanical power steering
- Lights up red: electromechanical power steering failure

### 11 - Cruise control system (CCS) warning lamp

- CCS regulating

### 12 - Indicator lamp for "Operate foot brake"

- Indicator lamp only fitted in vehicles with automated manual gearbox
- Request from automated manual gearbox (SQ)

### 13 - Coolant temperature indicator lamp (red)

- Coolant temperature too high or
- Coolant level too low.

### 14 - Oil pressure warning lamp

- Oil pressure too low
- Switch off engine and check oil level

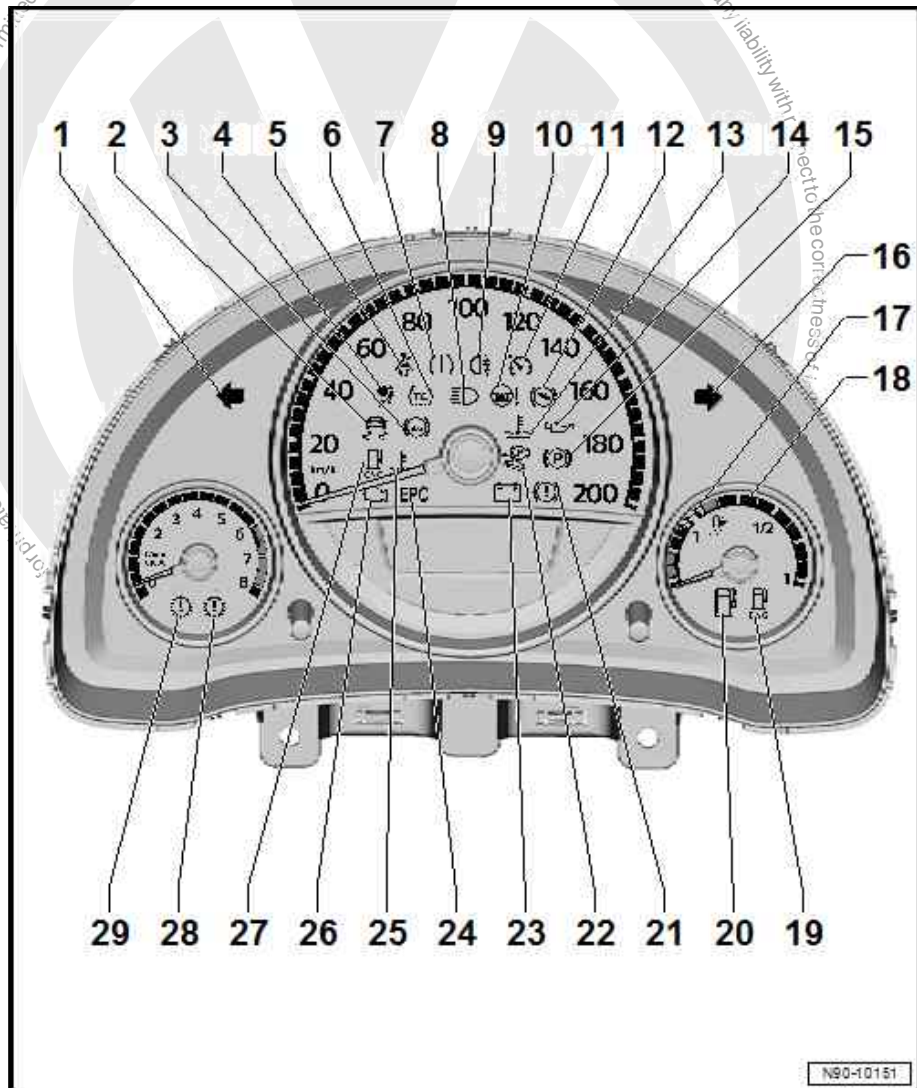





**15 - Parking brake indicator lamp**

- Parking brake applied

**16 - Indicator lamp for right turn signal**

- Switched on

**17 - Fuel gauge for petrol**

**18 - Fuel gauge for natural gas**

**19 - Indicator lamp for natural gas level**

- Fuel level too low (reserve)

**20 - Indicator lamp for fuel level**

- Fuel level too low (reserve)

**21 - Brake system warning lamp**

- Lights up: fault in brake system
- Lights up: brake fluid low - stop engine, and check brake fluid level

**22 - Indicator lamp for automated manual gearbox**

- Flashes: vehicle is not secured against rolling away

**23 - Indicator lamp for alternator**

- Fault in alternator

**24 - Indicator lamp for engine fault EPC (electric throttle)**

- Fault

**25 - Coolant temperature indicator lamp (blue)**

- Coolant temperature too low

**26 - Indicator lamp for Electric On Board Diagnosis (EOBD)**

- Fault in exhaust system

**27 - Indicator lamp for natural gas level**

- Natural gas tank almost empty

**28 - Indicator lamp for fault in automated manual gearbox (red)**

- Indicator lamp only fitted in vehicles with automated manual gearbox
- Fault in automated manual gearbox

**29 - Indicator lamp for fault in automated manual gearbox (yellow)**

- Indicator lamp only fitted in vehicles with automated manual gearbox
- Automated manual gearbox overheated or gears cannot be shifted properly



### 1.1.3 Assembly overview - dash panel insert, rear



#### Note

The dash panel insert must not be dismantled. If necessary, the dash panel insert is renewed as a unit.

- 1 - Warning buzzer
- 2 - Connector

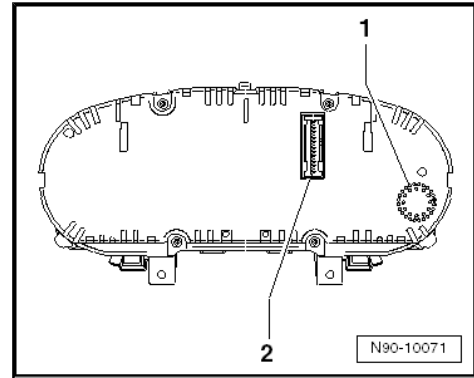

#### Note

Pin assignment of connectors on dash panel insert: → Current flow diagrams, Electrical fault finding and Fitting locations

### 1.2 Removing and installing dash panel insert - KX2-

#### Special tools and workshop equipment required

- ◆ Protective film - VAS 6773-



#### Note

- ◆ All indicator lamps in the dash panel insert - KX2- are equipped with light-emitting diodes. Light-emitting diodes cannot be renewed separately if defective. The dash panel insert must be renewed.
- ◆ The dash panel insert - KX2- must not be dismantled.
- ◆ It is not necessary to remove the steering wheel prior to removal of the dash panel insert - KX2- .
- ◆ If a new dash panel insert is installed, all ignition keys must be adapted.
- ◆ When renewing the dash panel insert - KX2- together with the control unit in dash panel insert - J285- , select **Renew** function for the respective control unit in **Guided Fault Finding** or **Guided Functions** mode → Vehicle diagnostic tester.
- Connect vehicle diagnostic tester → [page 157](#) .
- Read current data from dash panel insert (coding, service data, odometer reading) → Vehicle diagnostic tester.

#### Removing

- Switch off ignition and all electrical consumers, and withdraw ignition key.
- Lock steering wheel in lowest position.
- Loosen and remove gap cover of the steering column trim from dash panel ⇒ General body repairs, interior; Rep. gr. 68 ; Storage compartments/covers; Removing and installing gap cover in dash panel insert .



- Undo and remove bolts -arrows- securing dash panel insert -1-.

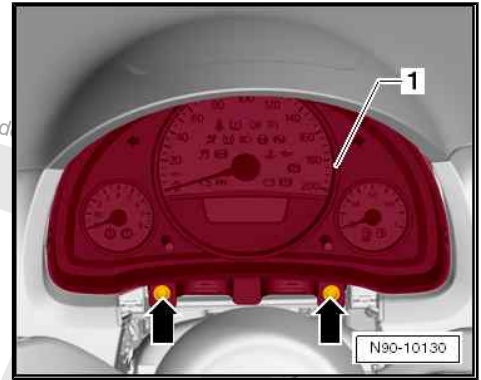

- Push protective films -1- on left and right into gap -arrows- between dash panel insert and dash panel cowling. If the protective film is not used, the dash panel cowling and the edge of the dash panel will be scratched near the dash panel insert.

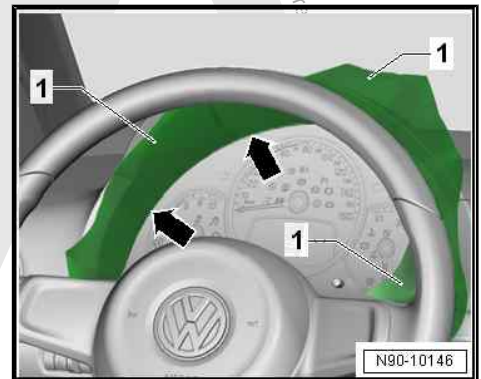

- Pull dash panel insert -1- straight forwards out of dash panel, taking connected wiring lengths into consideration.

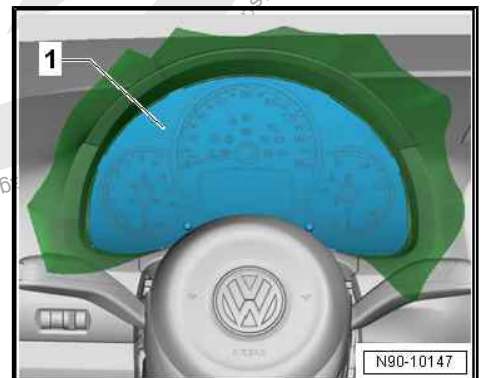

- Swing locking bar -1- in -direction of arrow- and pull off connector -2-.
- Remove dash panel insert from vehicle.

**Installing**

Install in the reverse order of removal observing the following:

**Specified torques**

Component	Specified torque
Securing bolts for securing dash panel insert to dash panel	1.5 Nm

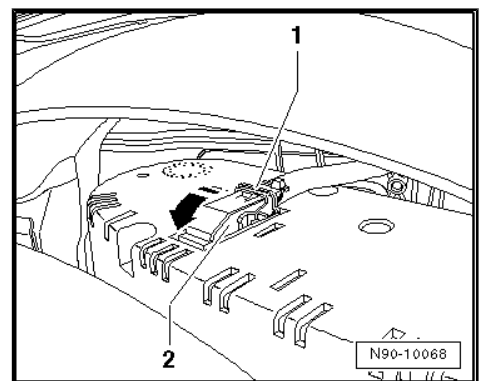



## 2 Horn

⇒ "2.1 Assembly overview - horn", page 38

⇒ "2.2 Removing and installing treble horn H2 and bass horn H7", page 39

### 2.1 Assembly overview - horn

#### 1 - Bracket

- For horn

#### 2 - Bass tone horn - H7-

- Removing and installing  
⇒ [page 39](#) .

#### 3 - Bolt

- 20 Nm

#### 4 - Bracket

- For horn

#### 5 - Nut

- 9 Nm

#### 6 - Treble tone horn - H2-

- Removing and installing  
⇒ [page 39](#) .

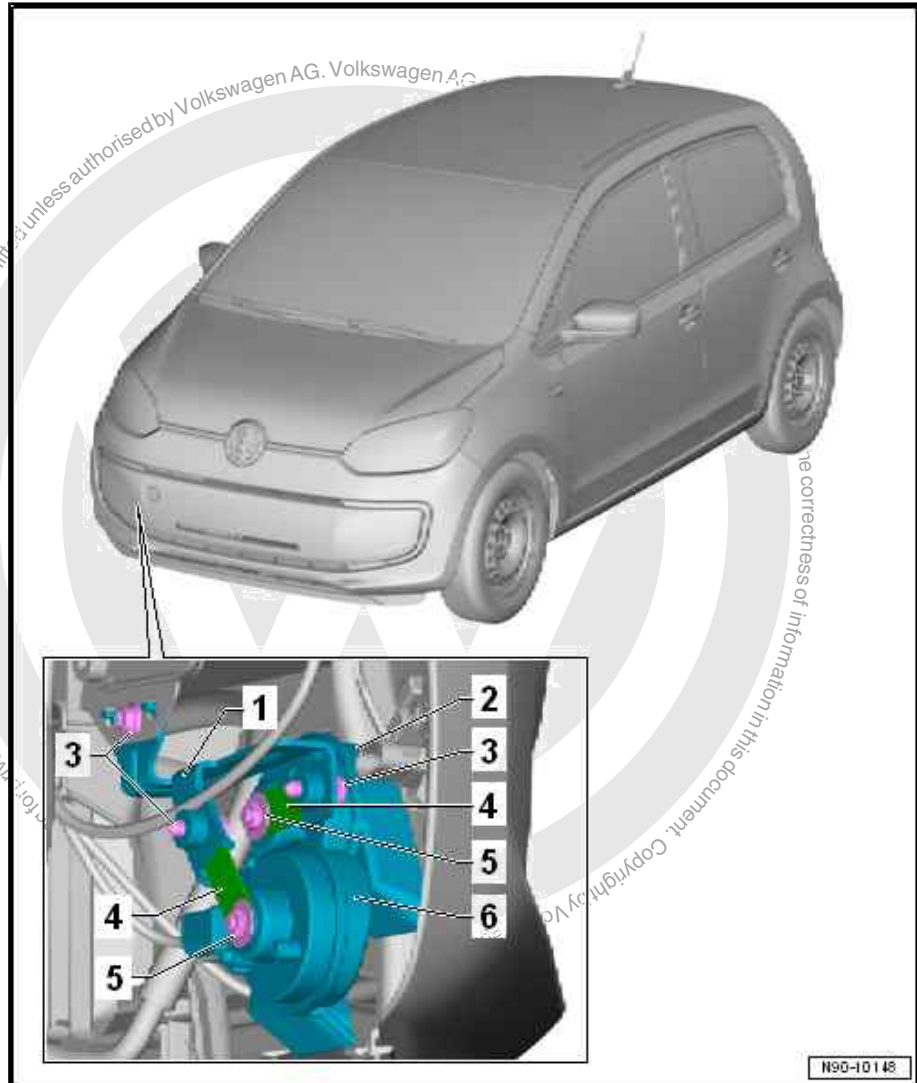



## 2.2 Removing and installing treble horn - H2- and bass horn - H7-

### Removing

- Unscrew bolt -1-.
- Remove bracket together with horns -2-.
- Disconnect connector.

### Removing horns from bracket

- Remove horns together with bracket ⇒ [page 39](#) .

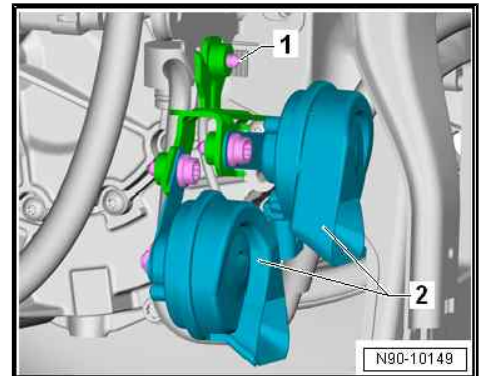

- Unscrew bolts -1-.
- Remove horns -2-.

### Installing

Install in the reverse order of removal, observing the following:

### Specified torques

- ◆ ⇒ ["2.1 Assembly overview - horn", page 38](#)

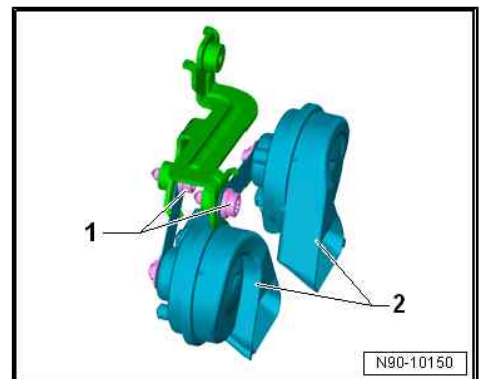

## 92 – Windscreen wash/wipe system

### 1 windscreen wiper system.

⇒ [“1.1 Assembly overview - windscreen wiper system”, page 40](#)

⇒ [“1.2 Moving wipers to service position”, page 41](#)

⇒ [“1.3 Removing and installing wiper blade”, page 41](#)

⇒ [“1.4 Removing and installing wiper arms”, page 42](#)

⇒ [“1.5 Adjusting wiper arms”, page 44](#)

⇒ [“1.6 Renewing windscreen wiper rubber”, page 46](#)

⇒ [“1.7 Removing and installing wiper motor V”, page 47](#)

⇒ [“1.8 Renewing wiper motor”, page 49](#)

### 1.1 Assembly overview - windscreen wiper system

#### 1 - Joint-free wipers

- ❑ Removing and installing  
⇒ [page 41](#)

#### 2 - Wiper arms

- ❑ Removing and installing  
⇒ [page 42](#)
- ❑ Adjusting ⇒ [page 44](#)

#### 3 - Wiper arm securing nut to linkage

- ❑ Specified torque: 20 Nm

#### 4 - Caps

#### 5 - Wiper frame securing bolts with linkage to body

- ❑ Specified torque: 8 Nm

#### 6 - Wiper frame with linkage

- ❑ Removing and installing  
⇒ [page 47](#)

#### 7 - Wiper motor securing bolts to wiper frame with linkage

- ❑ Specified torque: 9 Nm

#### 8 - Securing nut of motor crank of wiper motor shaft

- ❑ Specified torque: 25 Nm

#### 9 - Wiper motor - V- with control unit for wiper motor - J400

- ❑ Removing and installing  
⇒ [page 47](#)
- ❑ Renewing ⇒ [page 49](#)

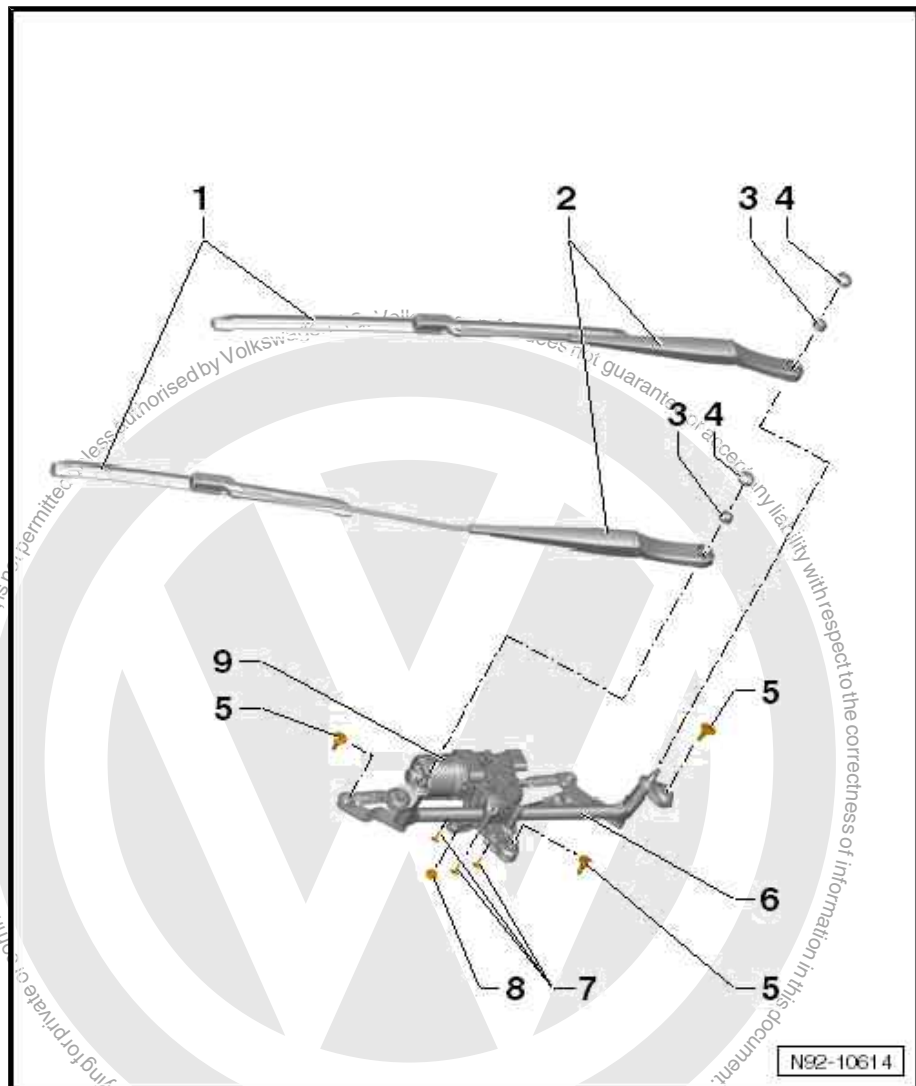





## 1.2 Moving wipers to service position



### Caution

**Risk of damaging the bonnet when moving wipers back into the park position.**

- ◆ Do not manoeuvre the vehicle with wiper arms folded out.
- ◆ The wipers automatically move back to the park position when the wiper switch is operated or when road speed exceeds 6 km/h.



### Caution

**Risk of damage to wiper blades due to freezing.**

- ◆ In the event of frost, check if wiper blades are frozen.



### Note

*If it is necessary for the windscreen wiper motor to run during the working procedure, the bonnet must be closed completely, as otherwise the power supply to the wiper motor will be interrupted.*

- Switch on ignition briefly, then switch it off again.
- Actuate “flick wiper” function within 10 seconds. The wipers are moving to “service position”.

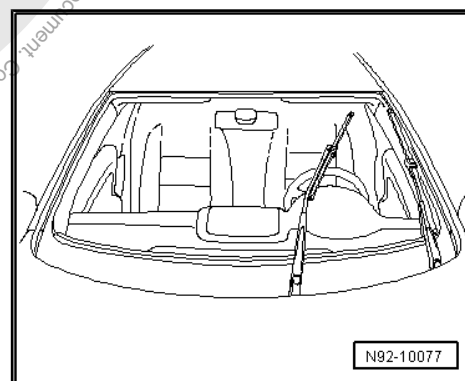

## 1.3 Removing and installing wiper blade

### Removing



### Caution

**Risk of damage to the wiper blade.**

- ◆ Joint-free wipers are very flexible. To lift the wiper blades off the windscreen, touch them only in the area in which the wiper blades are attached to the wipers.

- Move wipers to service position ⇒ [page 41](#) .
- Lift up wiper arm.





- Press button -1- and pull wiper blade mounting -3- out of wiper arm -2- in -direction of arrow-.

### Installing

Install in the reverse order of removal observing the following:



#### Caution

*Risk of damage to the vehicle body.*

- ◆ *Wiper blades for driver and front passenger sides each have a different length.*

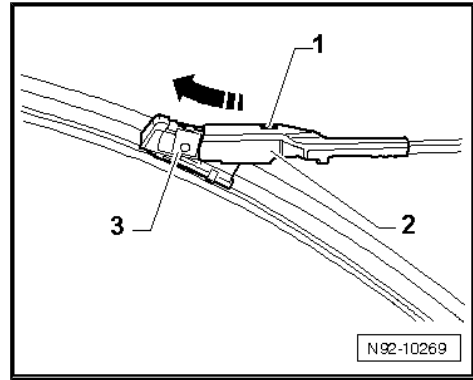

- Push wiper blade -3- onto wiper arm -2- as far as stop. Ensure that wiper blade is pushed into wiper arm until retaining clip is heard to engage.
- Carefully fold wiper arm back onto windscreen.

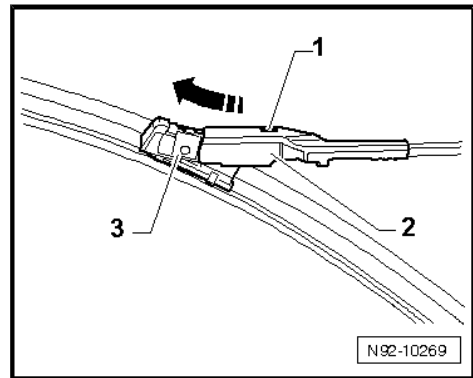

## 1.4 Removing and installing wiper arms

### Special tools and workshop equipment required

- ◆ Puller - T10369/1-

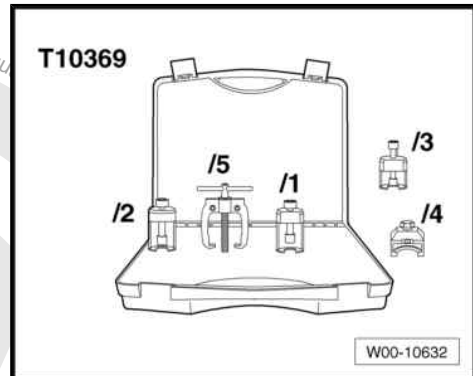

### Removing



#### Caution

*Risk of damage to wiper shafts.*

- ◆ *There is a risk of damage to the wiper shafts when trying to release the wiper arms without using the puller - T10369/1-.*



**i** Note

- ◆ *If it is necessary for the wiper motor to run during the working procedure, the bonnet must be closed as otherwise the power supply to the wiper motor will be interrupted.*
- ◆ *The removal and installation procedure is described for left-hand drive vehicles. Removal and installation for right-hand drive vehicles is similar.*
- Move wipers to service position ⇒ [page 41](#) .
- Switch off ignition and all electrical consumers, and withdraw ignition key.
- Lever off cover caps -arrows- using a screwdriver.

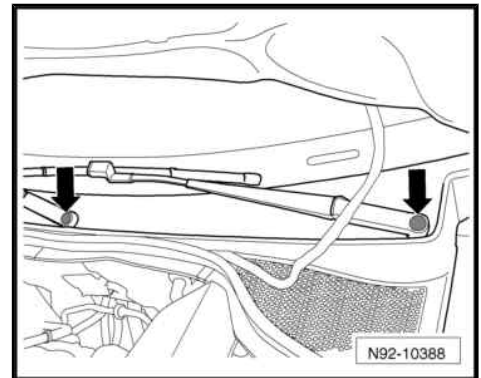

- Loosen nuts -arrows- a few turns.

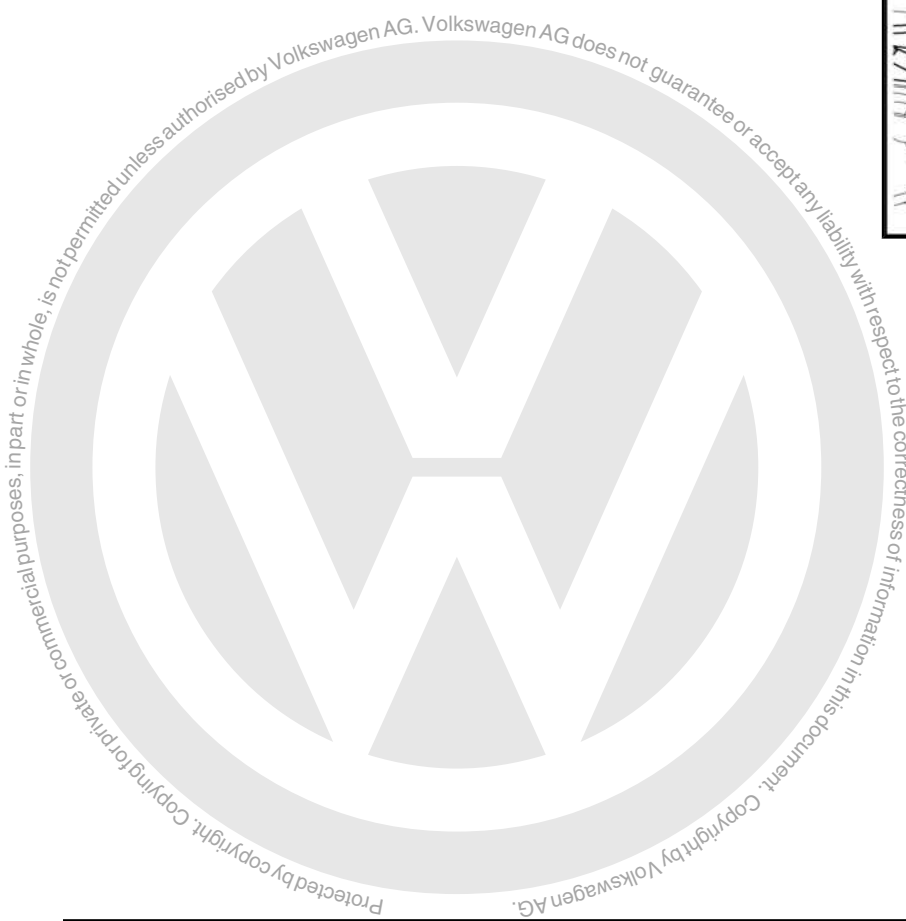
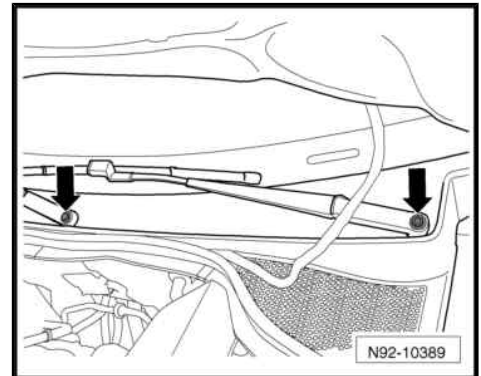



- Slide legs of puller - T10369/1- -2- under wiper arm -4- as shown in the illustration.



### Caution

*The wiper shaft may be damaged.*

*Always use thrust piece -3- to loosen wiper arm.*

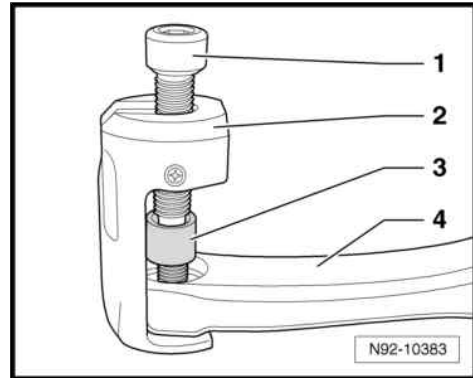

- Turn thrust bolt -1- of puller clockwise until thrust piece -3- comes into contact with wiper shaft. Turn thrust bolt -1- of puller clockwise using an Allen key (6 mm AF) until wiper arm -4- is loosened off shaft.
- Remove puller and wiper arm.
- Repeat this process with the second wiper arm.

### Installing

Install in the reverse order of removal observing the following:



### Caution

*Risk of damage to the vehicle body.*

- ◆ *Wiper arms for driver and front passenger sides each have a different length.*

- Close bonnet.
- Switch on ignition.
- Actuate "flick wipe" function and allow wiper motor to move to its end position.
- Switch off ignition.
- Open bonnet.
- Fit wiper arm together with attached wiper blade onto wiper shaft.
- Fit the two wiper arms in approximate park position on wiper arm shafts and tighten securing nuts -arrows- by hand.
- Adjust wiper arms ⇒ [page 44](#) .

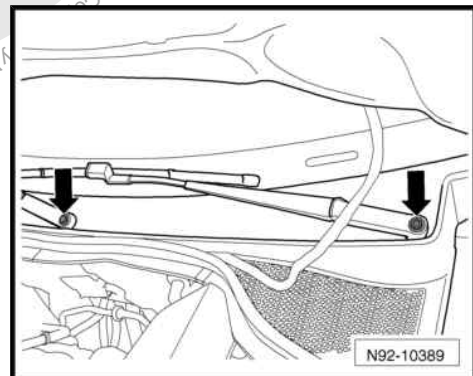

## 1.5 Adjusting wiper arms

Special tools and workshop equipment required



- ◆ Torque wrench - V.A.G 1331-

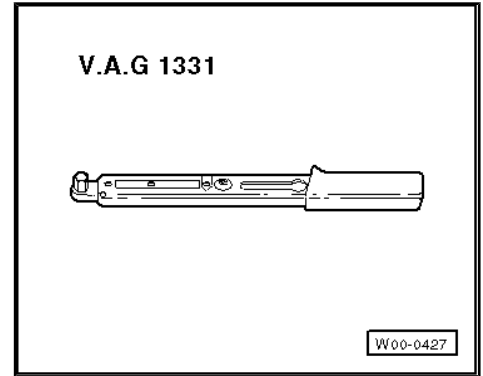

**i** Note

The removal and installation procedure is described for left-hand drive vehicles. Removal and installation for right-hand drive vehicles is similar.

- Move wipers to park position and then switch off ignition.
- Adjust windscreen wiper park position.

**i** Note

The specified setting position for the wiper blade park position -a- must be measured and adjusted between the middle of the wiper blade tip -1- and the top of the plenum chamber cover -2-.

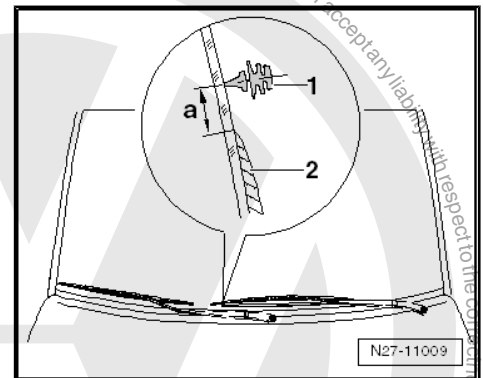

**Driver side:**

Set wipers to dimension -a- between centre of wiper rubber -1- and upper edge of plenum chamber cover -2-.

- ◆ Dimension -a- = 30 mm.
- Adjust wiper blade park position by moving wiper arm if necessary ⇒ [page 42](#) .
- Tighten nut.

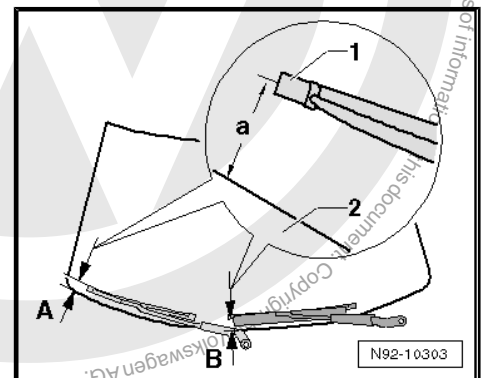



### Front passenger side:

Set wipers to dimension -a- between centre of wiper rubber -1- and upper edge of plenum chamber cover -2-.

- ◆ Dimension -a- = 30 mm.
- Adjust wiper blade park position by moving wiper arm if necessary ⇒ [page 42](#) .
- Tighten nut.

### Specified torques

- ◆ ⇒ ["1.1 Assembly overview - windscreen wiper system"](#), [page 40](#)

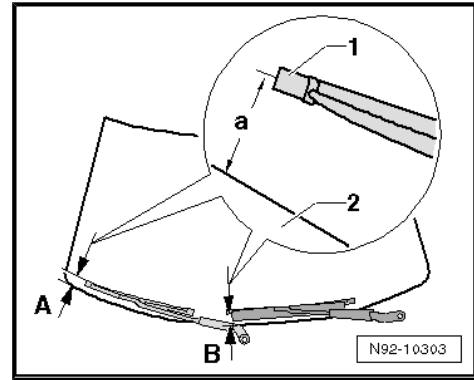

## 1.6 Renewing windscreen wiper rubber



### Note

Refer to chapter »Distinguishing features of joint-free wiper blades« in Workshop manual "Electrical system, General information". A link to this workshop manual is not possible at present for technical reasons. Please select the workshop manual "Electrical System, General Information" manually in ELSA.

- Remove wiper blade ⇒ [page 41](#) .
- Check to see on which side the wiper rubber blade cannot be pushed into the guide.
- On the side that cannot be pushed into the guide, carefully lever off the cap -1-.

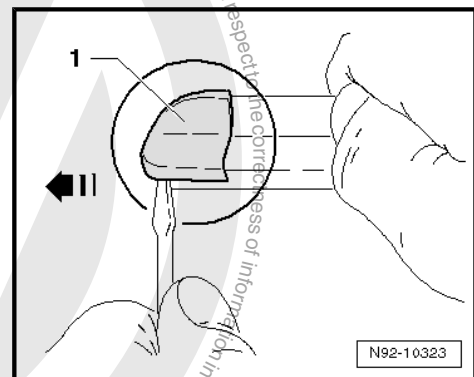

- Using a suitable screwdriver, open the wiper rubber stop -A- by bending up.
- Renew wiper rubber blade.



### Note

Ensure that wiper rubber blade is seating correctly in wiper rubber blade guides.

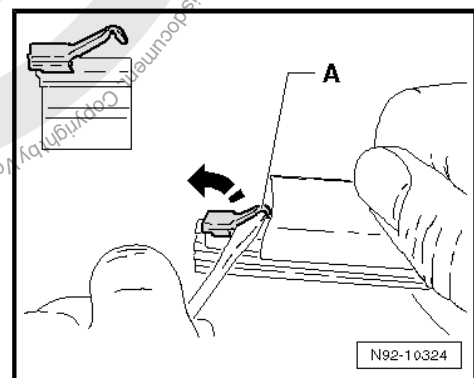



- Push wiper blade stop -A- back down using a suitable screwdriver until wiper rubber blade can no longer be moved in the guide.

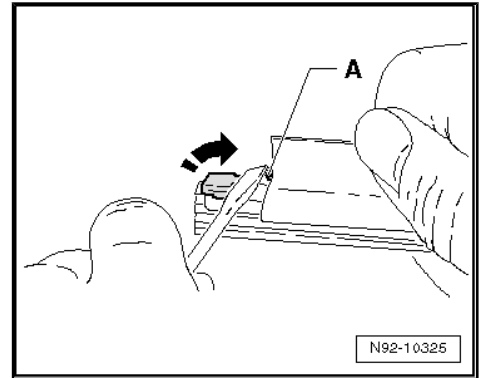

- Fit new cap -1- and check it is seated securely.
- Fit windscreen wiper blade => [page 41](#) .
- Check wiper blade is working correctly.

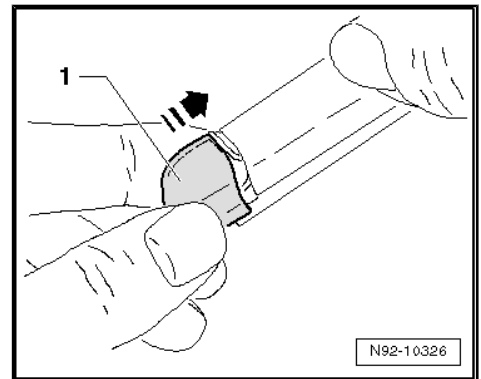

## 1.7 Removing and installing wiper motor - V-



### Caution

To disconnect and reconnect the battery, the procedure described in the workshop manual should be strictly adhered to => [page 5](#) .



### Note

- ◆ The wiper motor control unit - J400- and the wiper motor - - are combined to form one unit. If the wiper motor control unit - J400- is renewed, the coding must be read out first and the new wiper motor control unit - J400- must be code with this value.
- ◆ The illustrations show removal and installation of the windscreen wiper system in an LHD vehicle.
- ◆ Removal and installation of the windscreen wiper system in an RHD vehicle are analogous.

### Special tools and workshop equipment required



- ◆ Torque wrench - V.A.G 1331-

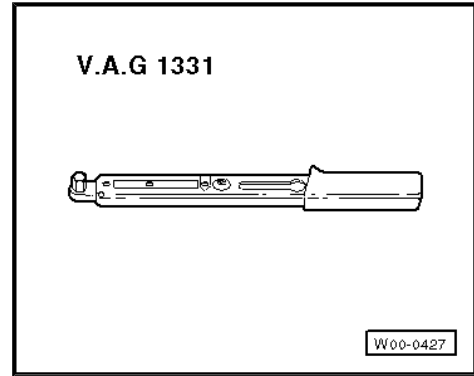

### Removing

- All wiper arms to move to park position and then switch off ignition.
- Disconnect battery ⇒ [page 5](#) .
- Remove wiper arms ⇒ [page 42](#) .
- Remove plenum chamber cover ⇒ General body repairs, exterior; Rep. gr. 50 ; Bulkhead; Assembly overview - plenum chamber cover .
- Undo screws -arrows- and pull wiper frame together with linkage and motor -1- sideways so that they come out of the plenum chamber a little, taking connected wiring lengths into consideration.

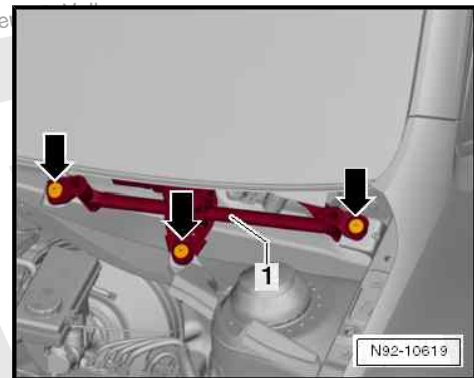

- Release and pull off connector -1-, and remove wiper frame together with linkage and motor -2- from vehicle.

### Installing

Install in the reverse order of removal observing the following:

- Insert wiper frame together with linkage and wiper motor -1- into plenum chamber.

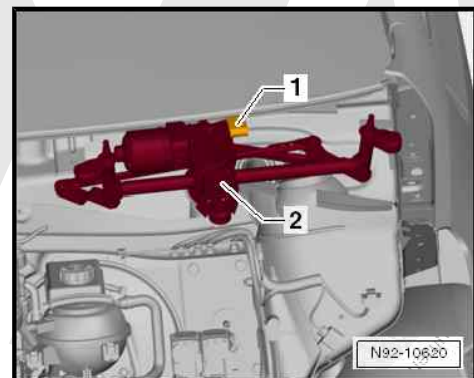





- Screw in securing bolts -arrows-.
- Push connector onto connection on wiper motor so that connector latches into place.
- Install plenum chamber cover => General body repairs, exterior; Rep. gr. 50 ; Bulkhead; Assembly overview - plenum chamber cover
- Connect battery => [page 5](#) .
- Installing wiper arms => [page 42](#) .

### Specified torques

- ◆ ["1.1 Assembly overview - windscreen wiper system", page 40](#)

## 1.8 Renewing wiper motor

### Special tools and workshop equipment required

- ◆ Removal lever - 80-200-
- ◆ Torque wrench - V.A.G 1331-

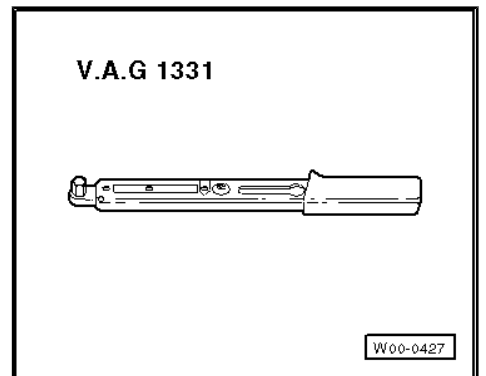
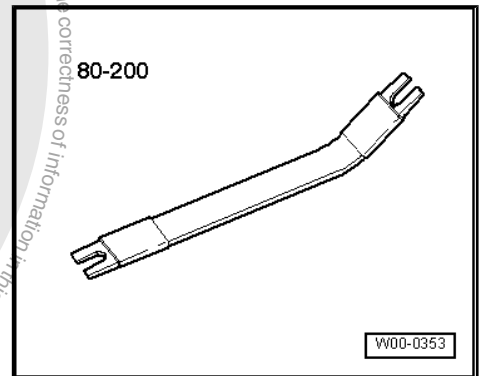
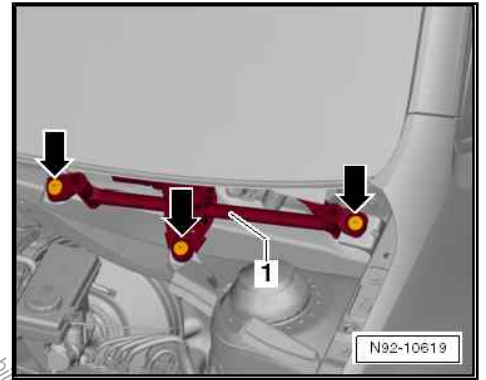

### Removing

- Remove windscreen wiper motor => [page 47](#) .
- Lever linkage -1- off ball head of motor crank arm -arrow- using removal lever - 80-200- .

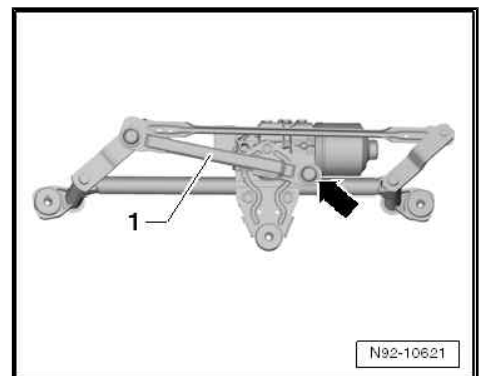



- Unscrew securing nut -1-, and pull motor crank -3- off wiper motor shaft.
- Undo screws -arrows-, then pull retaining plate -4- and wiper motor together with control unit -2- out of the wiper frame.

### Installing



#### WARNING

- ◆ *Danger from pinching!*
- ◆ *Danger of becoming caught/pinched in the rotating parts*
- ◆ *Do not hold wiper motor near rotating parts after it has been removed.*

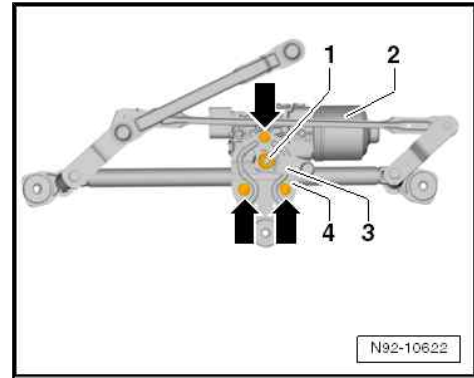

- Operate wiper motor briefly until park position is reached:
- ◆ Reconnect battery.
- ◆ Attach connector to wiper motor.
- ◆ Briefly press the windscreen wiper switch (flick wipe) with the ignition switched on and allow the wiper motor to return to the park position.
- ◆ Switch off ignition.
- ◆ Release connector and pull it off the wiper motor.
- ◆ Disconnect battery.

- Insert wiper motor with control unit -2- into wiper frame, place retaining plate -1- in position, and secure it with 3 bolts -arrows-.
- Screw in the 3 securing bolts -arrows-.

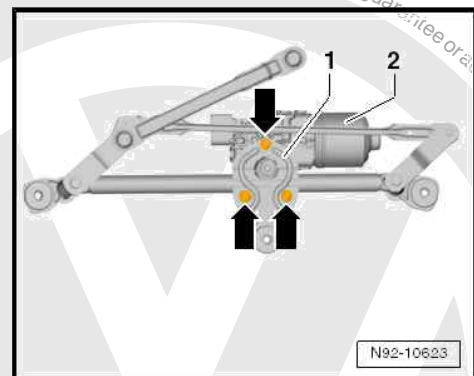

- Fit motor crank -4- onto shaft of wiper motor -2- so that the 3 illustrated points -1-, -2- and -3- are in line with each other.
- Screw on securing nut -5-.

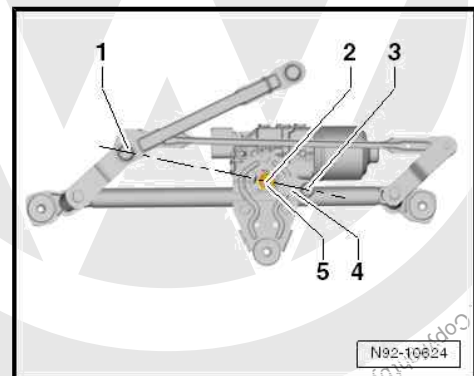



- Press ball head -arrow- of linkage -1- onto motor crank until it latches into place.
- Install windscreen wiper motor => [page 47](#) .

### Specified torques

- ◆ => ["1.1 Assembly overview - windscreen wiper system", page 40](#)

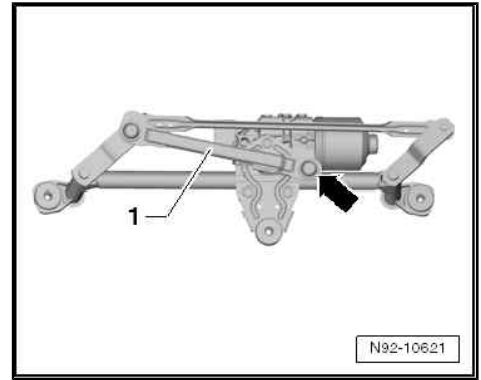



## 2 Windscreen washer system

⇒ ["2.1 Assembly overview - windscreen washer system", page 52](#)

⇒ ["2.2 Removing and installing washer fluid reservoir", page 53](#)

⇒ ["2.3 Removing and installing windscreen washer pump", page 54](#)

⇒ ["2.4 Removing and installing spray jets", page 55](#)

⇒ ["2.5 Adjusting spray jets", page 56](#)

### 2.1 Assembly overview - windscreen washer system

#### 1 - Angled piece

- ❑ Connection to right windscreen washer system spray jet
- ❑ Overview of hose couplings for washer fluid lines ⇒ [page 63](#)

#### 2 - Right windscreen washer system spray jet

- ❑ Removing and installing ⇒ [page 55](#)
- ❑ Adjusting ⇒ [page 56](#)

#### 3 - Angled piece

- ❑ Connection to left windscreen washer system spray jet
- ❑ Overview of hose couplings for washer fluid lines ⇒ [page 63](#)

#### 4 - Left windscreen washer system spray jet

- ❑ Removing and installing ⇒ [page 55](#)
- ❑ Adjusting ⇒ [page 56](#)

#### 5 - Y-piece

- ❑ Distribution of wash water line to windscreen washer system spray jets

#### 6 - Hose

- ❑ Repairing washer fluid

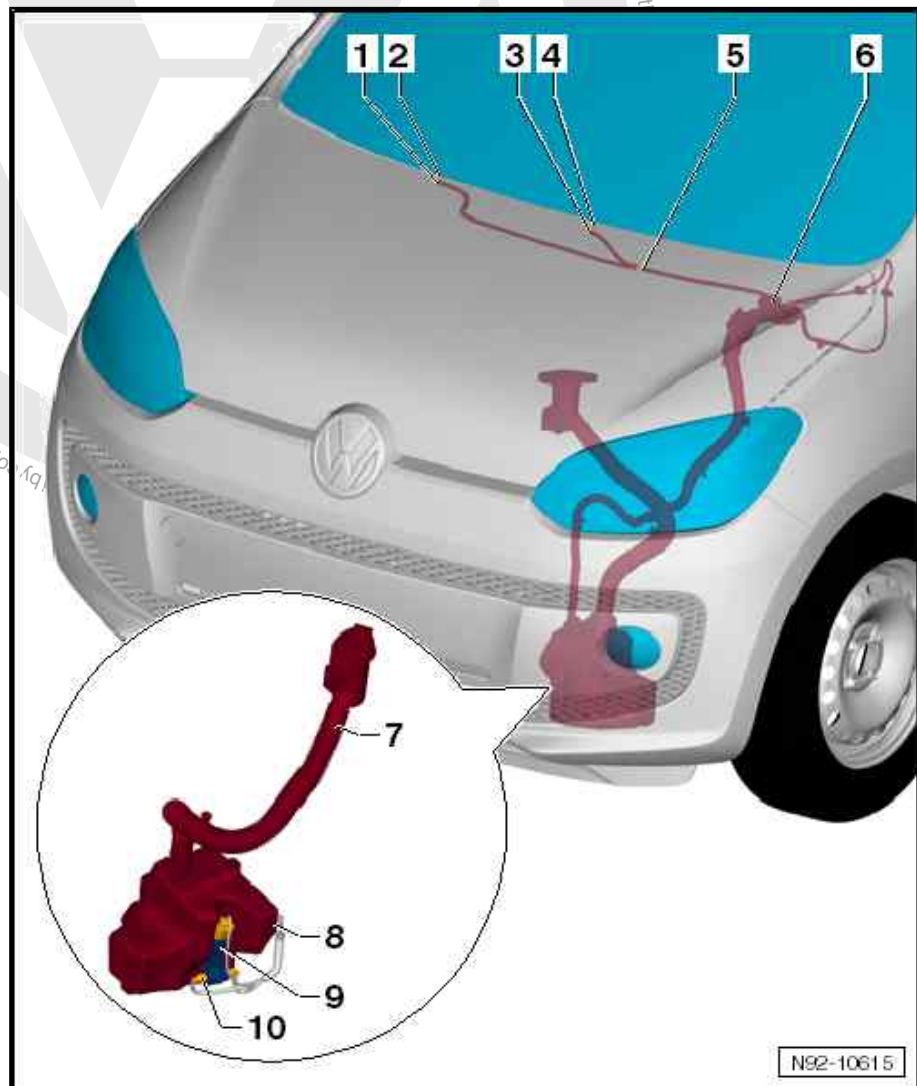



lines ⇒ [page 63](#)

### 7 - Connecting pipe with filler neck to reservoir

- ❑ Removed and installed together with reservoir ⇒ [page 53](#)

### 8 - Washer fluid reservoir

- ❑ Removing and installing ⇒ [page 53](#)
- ❑ Specified torque of bolt for securing reservoir to body - 8 Nm

### 9 - Windscreen and rear window washer pump - V59-

- ❑ Removing and installing ⇒ [page 54](#)

### 10 - Angled connection piece

- ❑ Connection to windscreen and rear window washer pump - V59-
- ❑ Overview of hose couplings for washer fluid lines ⇒ [page 63](#)

## 2.2 Removing and installing washer fluid reservoir

### Removing

- Switch off ignition and all electrical consumers, and withdraw ignition key.
- Remove front bumper cover ⇒ General body repairs, exterior; Rep. gr. 63 ; Front bumper; Assembly overview - front bumper cover .
- Press locking mechanism -arrow- and pull filler neck -1- upwards out of mounting on lock carrier.
- Pull windscreen and rear window washer pump - V59- -2- together with connected lines upwards out of reservoir -5-.
- Collect any escaping washer fluid in a suitable container.

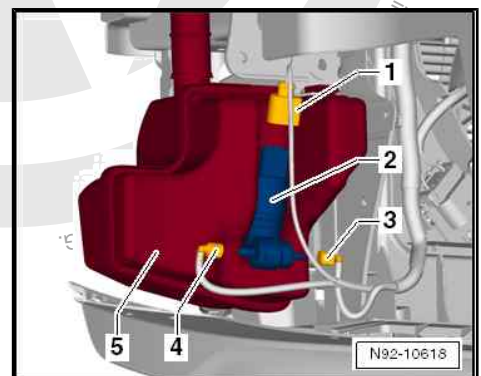
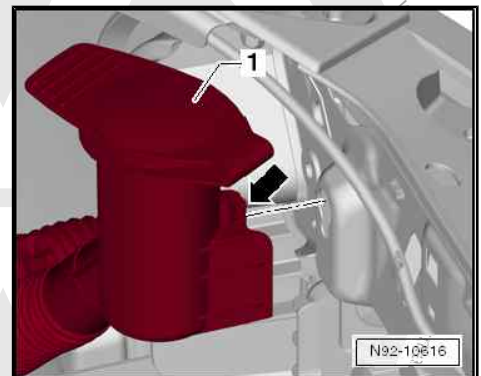



- Release connecting pipe clip together with filler neck -2- from body.
- Undo and remove securing bolt -5- and pull reservoir -4- out of guide -3- in -direction of arrow- towards the rear.
- Remove reservoir -4- together with connecting pipe and filler neck -1- from vehicle.

### Installing

Install in the reverse order of removal observing the following:

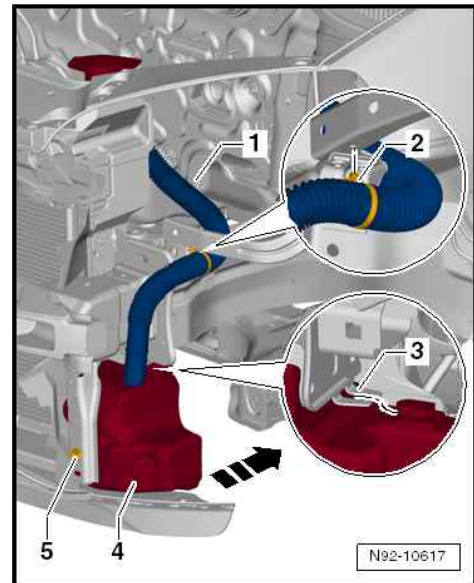

- Guide connecting pipe clip together with filler neck -1- upwards through body.
- Push reservoir -4- onto guide -3- and secure with bolt -5-.
- Secure connecting pipe together with filler neck -1- in body -2- and push filler neck into mounting on lock carrier until filler neck audibly engages.

### Specified torques

- ◆ ⇒ ["2.1 Assembly overview - windscreen washer system", page 52](#)

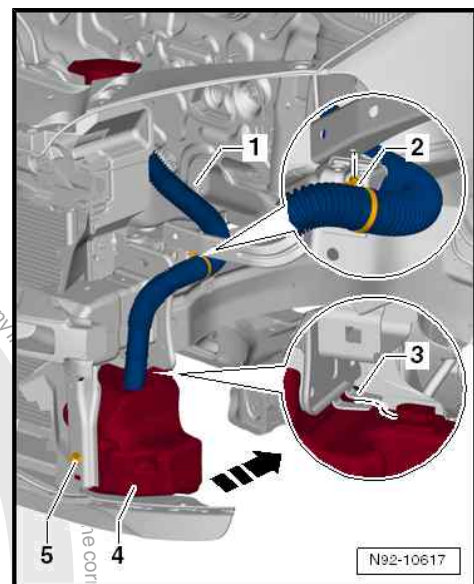

## 2.3 Removing and installing windscreen washer pump

### Removing

- Switch off ignition and all electrical consumers, and withdraw ignition key.
- Detach front left wheel housing liner in front area ⇒ General body repairs, exterior; Rep. gr. 63 ; Front bumper; Assembly overview - front bumper cover .





- To release, twist securing clips on angled connection pieces -3- and -4-, and pull connection pieces off windscreen and rear window washer pump - V59- -2-.
- Collect any escaping washer fluid in a suitable container.
- Pull windscreen and rear window washer pump - V59- -2- upwards out of reservoir -5-.
- Release and pull off connector -1-.

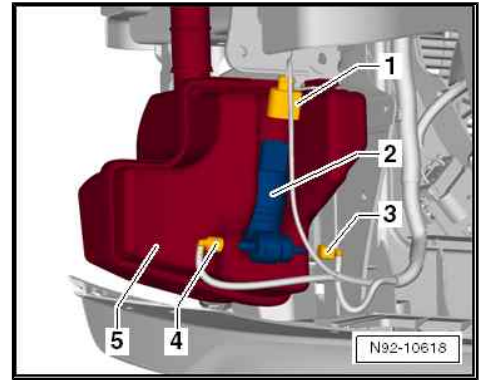

**i Note**

*The connections to the pump and hose lines are colour-coded in order to prevent the washer fluid lines being incorrectly connected to the front and rear washer fluid pump - V59- . The hose connections must be connected to the correct colour-coded pump connections during installation.*

**Installing**

Installation is carried out in the reverse sequence of removal.

**2.4 Removing and installing spray jets**

**Removing**

- Switch off ignition and all electrical consumers, and withdraw ignition key.
- Push spray jet upwards -arrow A- and pull out of front flap -arrow B-.

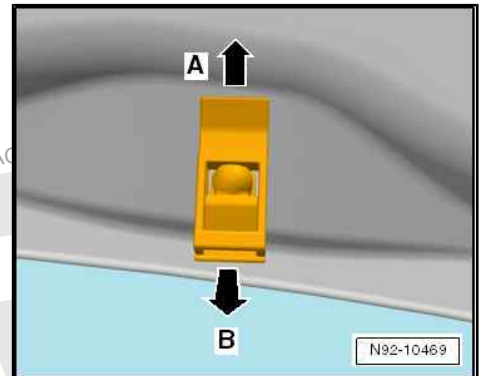

- Release securing clip -3- and pull hose connection -2- off spray jet.
- Depending on the equipment, release and pull off connector -1- and then remove spray jet.

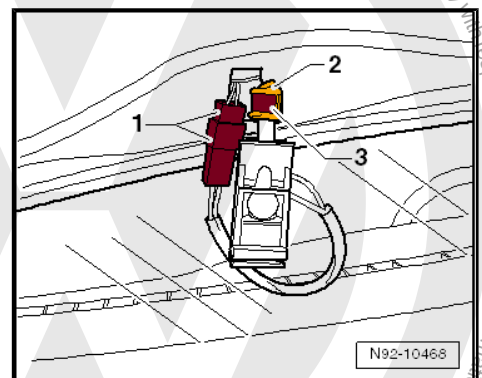

**Installing**





- Depending on the equipment, reconnect plug-in connection -1-.
- Fit hose connection -2- onto spray jet and lock hose clip -3-.
- Starting at the top, push spray jet into mounting hole until it locks in place audibly.
- Adjusting spray jets => [page 56](#) .

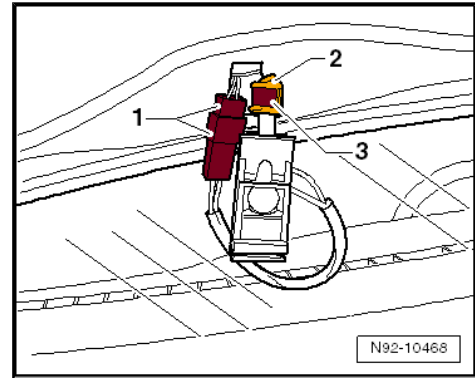

## 2.5 Adjusting spray jets



### Note

*In case of uneven spray field due to soiling in the spray jet, remove spray jet and rinse it through with water counter to spraying direction. Subsequent blowing through with compressed air against the spraying direction is permitted. Do not use any objects to clean the spray jets.*

Adjusting spray jets for windscreen washer system: "Maintenance manual" => Maintenance ; Booklet 35.1 ; Descriptions of work .

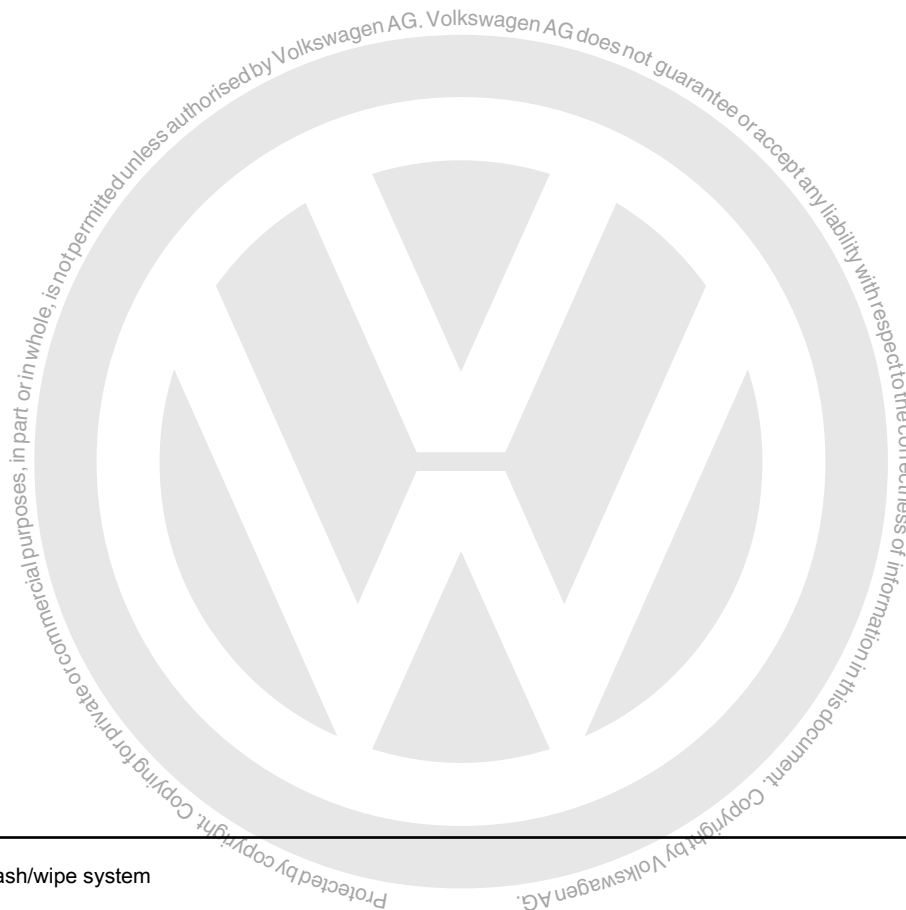



### 3 Rear window wiper system

⇒ [“3.1 Assembly overview - rear window wiper system”, page 57](#)

⇒ [“3.2 Removing and installing wiper blade”, page 58](#)

⇒ [“3.3 Removing and installing wiper arm”, page 58](#)

⇒ [“3.4 Adjusting wiper arm”, page 59](#)

⇒ [“3.5 Removing and installing rear window wiper motor V12”, page 60](#)

#### 3.1 Assembly overview - rear window wiper system

1 - Cover

2 - Securing nut

- ❑ Specified torque: 12 Nm

3 - Joint-free wiper blade

- ❑ Removing and installing  
⇒ [page 58](#)

4 - Wiper arm

- ❑ Removing and installing  
⇒ [page 58](#)
- ❑ Adjusting park position  
⇒ [page 59](#)

5 - Seal

- ❑ In rear window

6 - Rear window wiper motor - V12-

- ❑ Removing and installing  
⇒ [page 60](#)

7 - Spacer

8 - Rubber ring

9 - M6 securing nut with washer

- ❑ Specified torque: 8 Nm

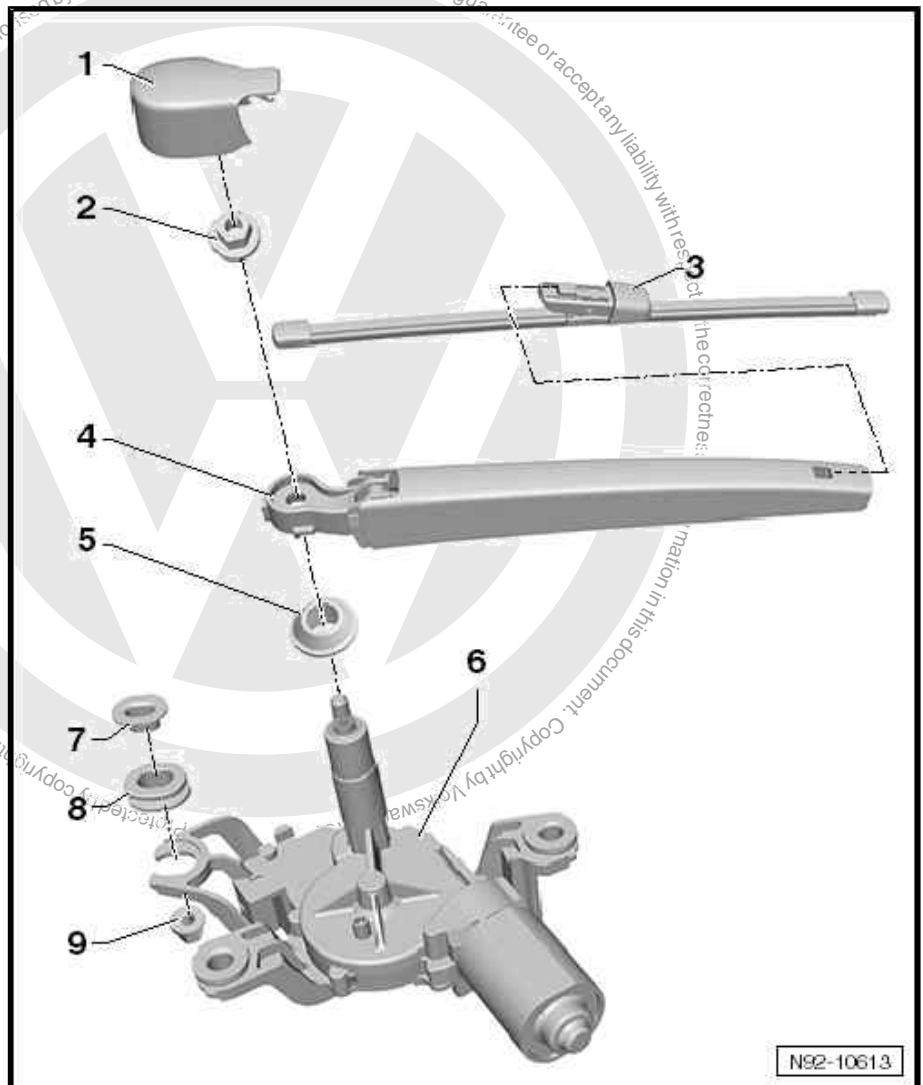



### 3.2 Removing and installing wiper blade

#### Removing



#### Caution

*Risk of damage to the wiper blade.*

- ◆ *Joint-free wipers are very flexible. To lift the wiper blades off the rear window, touch them only in the area in which the wiper blades are attached to the wipers.*

- Fold up wiper arm -2-.
- Press button -1- and push wiper blade -3- out of mounting in -direction of arrow-.

#### Installing

Install in the reverse order of removal, observing the following:  
The wiper blade should be heard to engage in the wiper arm.

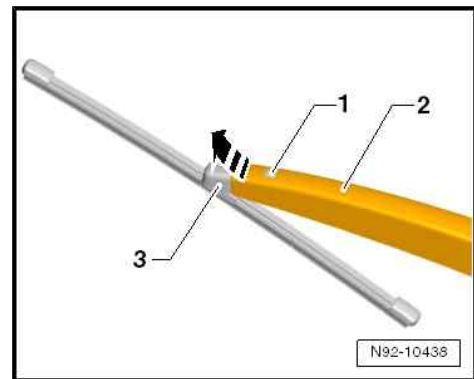

### 3.3 Removing and installing wiper arm

#### Special tools and workshop equipment required

- ◆ Puller - T10369-

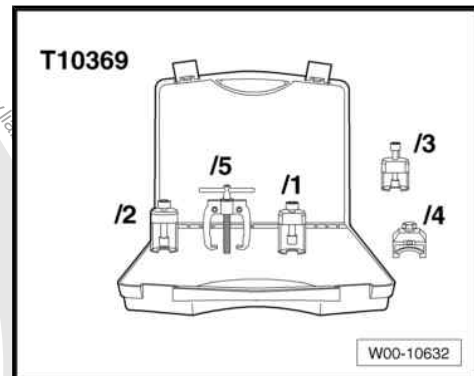

- ◆ Torque wrench - V.A.G 1331-

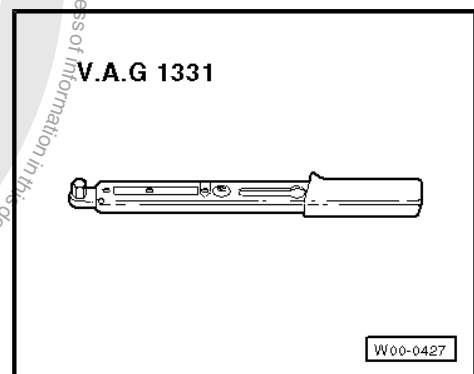

#### Removing

- Switch on ignition.



- Actuate "rear window wipe" function and allow wiper arm to move to its end position.
- Switch off ignition.
- Withdraw ignition key.
- Fold cover cap -1- of rear window wiper up and unclip it.
- Loosen but do not completely remove securing nut -arrow-.

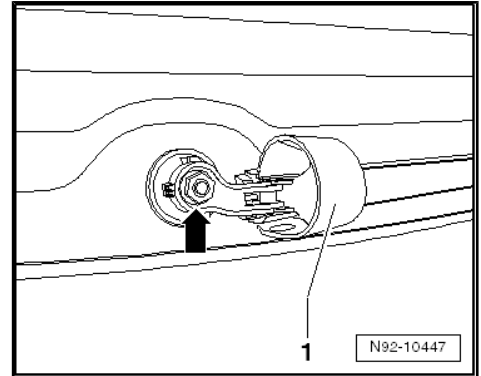

- Fit puller - T10369/5- to wiper arm -2-.
- Fit thrust piece -3- to wiper shaft.
- Screw in bolt -1- until wiper arm has been pulled off the wiper shaft.
- Unscrew nut -4- completely and remove wiper arm.

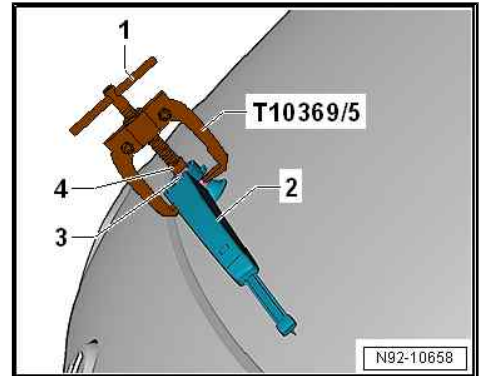

#### Installing

Install in the reverse order of removal, observing the following:

- Fit wiper arm in approximate park position on wiper shaft, and tighten securing nut -arrow- by hand .
- Adjust wiper arm => [page 59](#) .

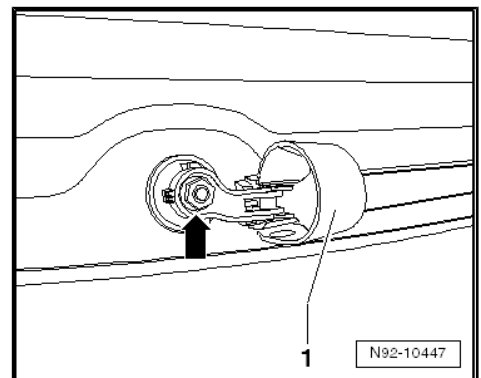

### 3.4 Adjusting wiper arm

#### Special tools and workshop equipment required

- ◆ Torque wrench - V.A.G 1331-

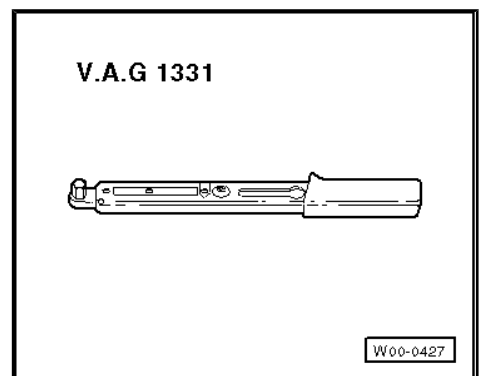



- To set the parking position, align the wiper blade tip with the lowest heating wire of the heated rear window
- Adjust rear window wiper park position by moving wiper arm if necessary ⇒ [page 58](#) .
- Tighten nut.

#### Specified torques

- ◆ ⇒ [“3.1 Assembly overview - rear window wiper system”, page 57](#)

### 3.5 Removing and installing rear window wiper motor - V12-

#### Special tools and workshop equipment required

- ◆ Torque wrench, V.A.G 1331-

#### Removing

- Remove wiper arm ⇒ [page 58](#) .
- Remove rear lid trim ⇒ General body repairs, interior; Rep. gr. 70 ; Luggage compartment trims; Fitting locations overview – luggage compartment trims .
- Release and pull off connector -1-.
- Remove securing nuts -arrows-.
- Remove rear window wiper motor - V12- -4-.

#### Installing

Install in the reverse order of removal observing the following:

- If necessary, moisten inner side of rear window seal with rubber and plastic compatible lubricant (e.g. polyethylene glycol).

- Check seal is seated correctly in opening of rear window. Mark -1- on seal must align with mark -2- on rear window.

#### Specified torques

- ◆ ⇒ [“3.1 Assembly overview - rear window wiper system”, page 57](#)

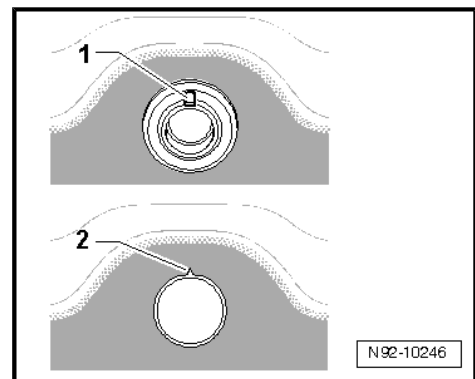
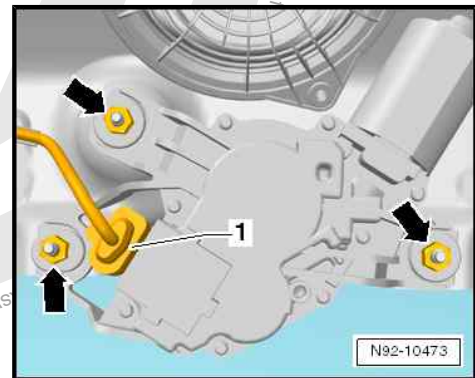



## 4 Rear window washer system

⇒ [“4.1 Assembly overview - rear window washer system”, page 61](#)

⇒ [“4.2 Removing and installing spray jet”, page 61](#)

⇒ [“4.3 Adjusting spray jet”, page 62](#)

### 4.1 Assembly overview - rear window washer system

**1 - Filler pipe with filler neck for reservoir for windscreen washer system**

- Removing and installing  
⇒ [page 53](#)

**2 - Windscreen and rear window washer pump - V59-**

- Removing and installing  
⇒ [page 54](#)

**3 - Washer fluid reservoir**

- Removing and installing  
⇒ [page 53](#)
- Specified torque of bolt for securing reservoir to body - 8 Nm

**4 - Angled connection piece**

- Connection to windscreen and rear window washer pump - V59-

**5 - Connection piece**

- Point of separation, interior wiring harness to rear lid wiring harness

**6 - Spray jet for rear window washer system**

- In high-level brake light
- Removing and installing  
⇒ [page 61](#)
- Adjusting ⇒ [page 62](#)

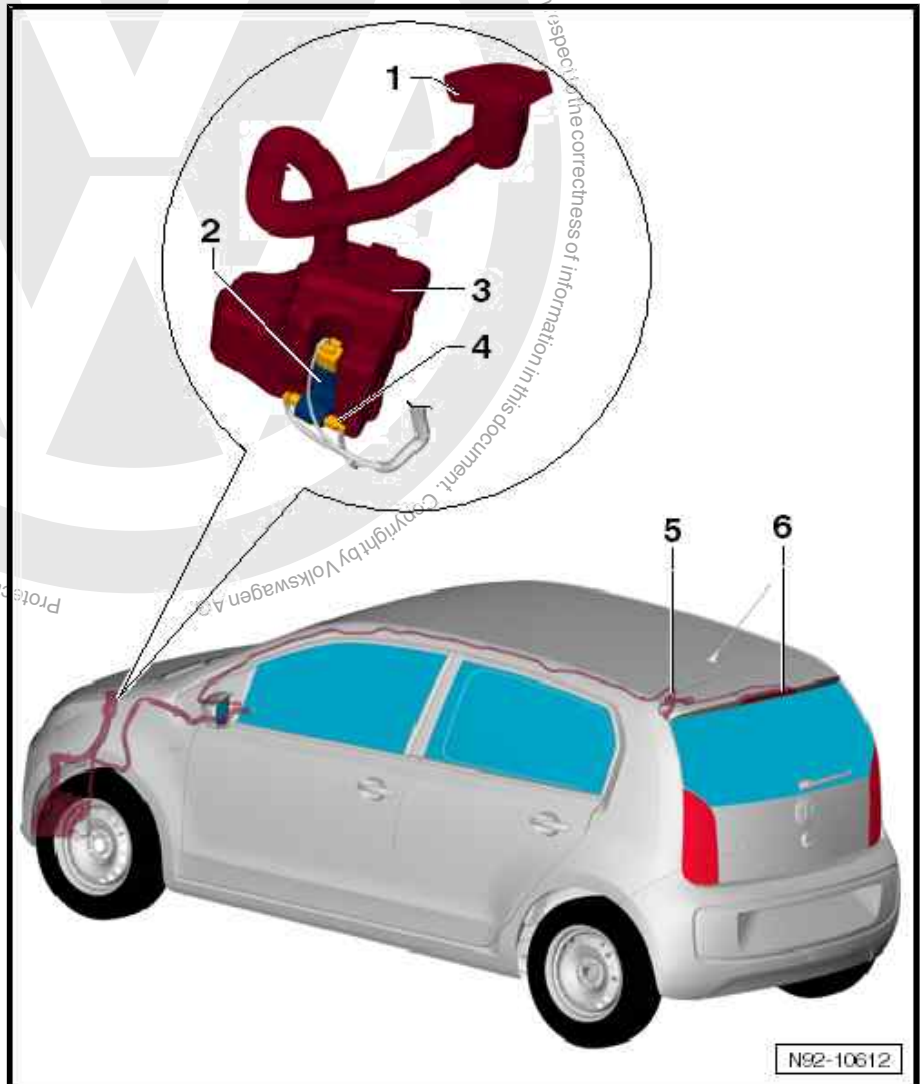

### 4.2 Removing and installing spray jet

The spray jet for rear window washer system is installed in high-level brake light - M25- .

#### Removing

- Remove high-level brake light - M25- ⇒ [page 90](#) .



- Release both catches -arrows- and pull spray jet -1- to rear out of high-level brake light - M25- .

#### Installing

- Install in reverse order of removal.
- Adjusting spray jet ⇒ [page 62](#) .

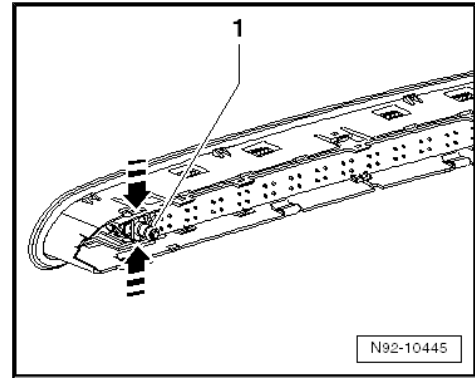

### 4.3 Adjusting spray jet



#### Note

*In case of uneven spray field due to impurities within the spray jet: remove spray jet and rinse it through with water, opposite to direction of spray. Subsequent blowing through with compressed air against the spraying direction is permitted. Do not use any objects to clean the spray jets.*

Adjusting rear window washer system spray jets “Maintenance manual” ⇒ Maintenance ; Booklet 35.1 ; Descriptions of work .

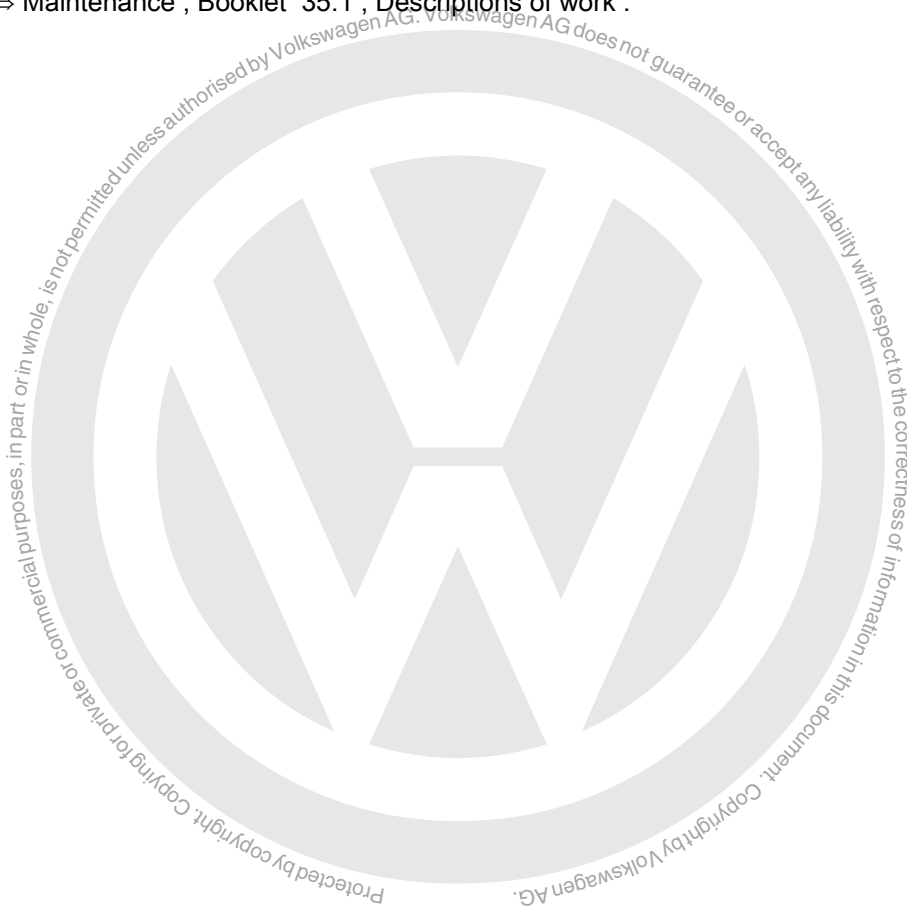





## 5 Washer fluid lines

⇒ **“5.1 Repairing washer fluid lines”, page 63**

### 5.1 Repairing washer fluid lines

All instructions and notes regarding this chapter are available under ⇒ Electrical System, General Information; Rep. gr. 92 ; Hose repair .

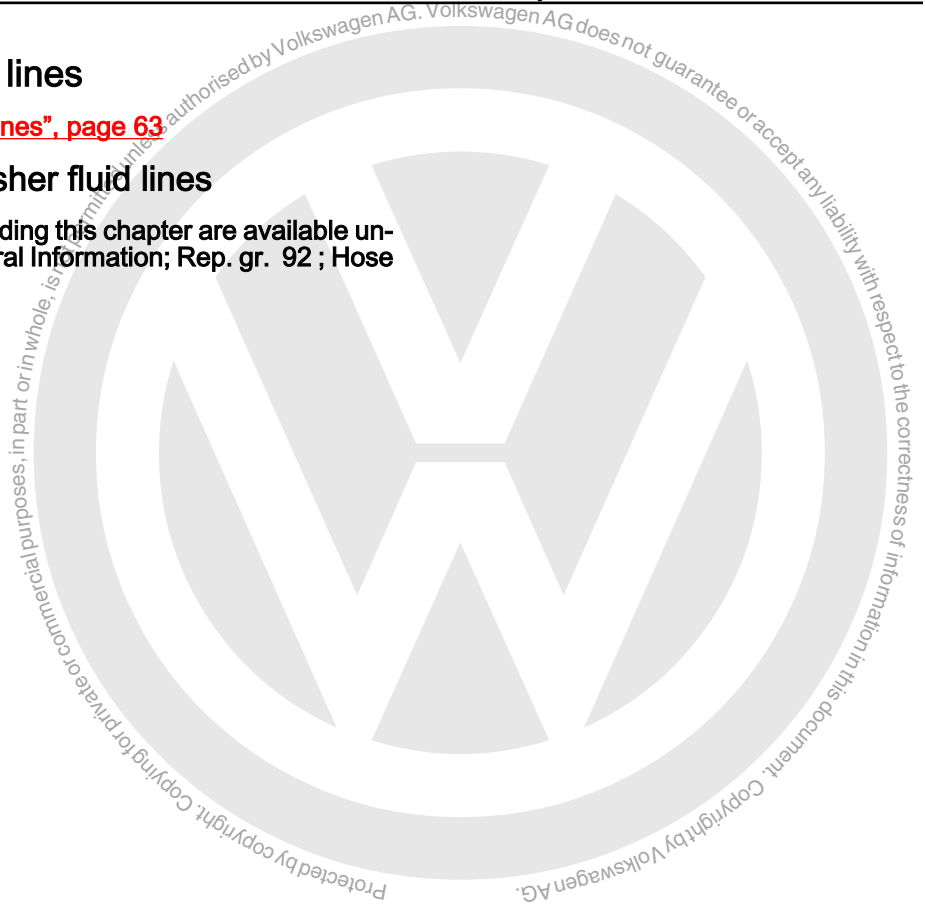



## 94 – Lights, bulbs, switches - exterior

### 1 Headlights

- ⇒ [“1.1 Assembly overview - headlight”, page 64](#)
- ⇒ [“1.2 Removing and installing headlight”, page 66](#)
- ⇒ [“1.3 Adjusting headlights”, page 67](#)
- ⇒ [“1.4 Adjusting headlight installation position”, page 67](#)
- ⇒ [“1.5 Removing and installing front turn signal bulb M5 / M7”, page 68](#)
- ⇒ [“1.6 Installing repair kit for headlight housing”, page 70](#)
- ⇒ [“1.7 Converting headlights from driving on right to driving on left”, page 73](#)
- ⇒ [“1.8 Converting headlights from driving on left to driving on right”, page 74](#)
- ⇒ [“1.9 Removing and installing headlight range control motor V48 / V49”, page 74](#)
- ⇒ [“1.10 Removing and installing dipped beam bulb”, page 75](#)
- ⇒ [“1.11 Removing and installing bulb for daytime running light/ side light”, page 77](#)

#### 1.1 Assembly overview - headlight



**1 - Inner bolt securing headlight to body**

- ❑ Specified torque: 4 Nm

**2 - Bracket securing bolts to body**

**3 - Carrier**

**4 - Front left turn signal bulb - M5- or front right turn signal bulb - M7-**

- ❑ Bulb 12V, PY21W
- ❑ Removing and installing ⇒ [page 68](#)

**5 - Bulb holder with grip element**

- ❑ For front left turn signal bulb - M5- or front right turn signal bulb - M7-

**6 - Bulb for daytime running light/side light**

- ❑ Left bulb which functions as bulb for left side light - M1- and bulb for left daytime running light - L174-
- ❑ Right bulb which functions as bulb for right side light - M3- and bulb for right daytime running light - L175-
- ❑ Bulb: 12 V, 21/5 W
- ❑ Removing and installing ⇒ [page 77](#)

**7 - Bulb holder with grip element**

- ❑ For side light/daytime running light bulb

**8 - Rear bolt securing headlight to body**

- ❑ Specified torque: 4 Nm

**9 - Upper bolt securing headlight to bracket**

- ❑ Specified torque: 4 Nm

**10 - Adapter**

**11 - Left headlight range control motor - V48- or right headlight range control motor - V49-**

- ❑ Removing and installing ⇒ [page 74](#)

**12 - Cover**

**13 - Bulb for dipped beam and main beam**

- ❑ Left bulb which functions as bulb for left dipped beam - M29- and bulb for left main beam - M30-
- ❑ Right bulb which functions as bulb for right dipped beam - M31- and bulb for right main beam - M32-
- ❑ Bulb H4 12V, 60/55W
- ❑ Removing and installing ⇒ [page 75](#)

**14 - Front left headlight - MX1- or front right headlight - MX2-**

- ❑ Removing and installing ⇒ [page 66](#)
- ❑ Correcting installation position of headlight ⇒ [page 67](#)
- ❑ Installing repair kit for headlight housing ⇒ [page 70](#)

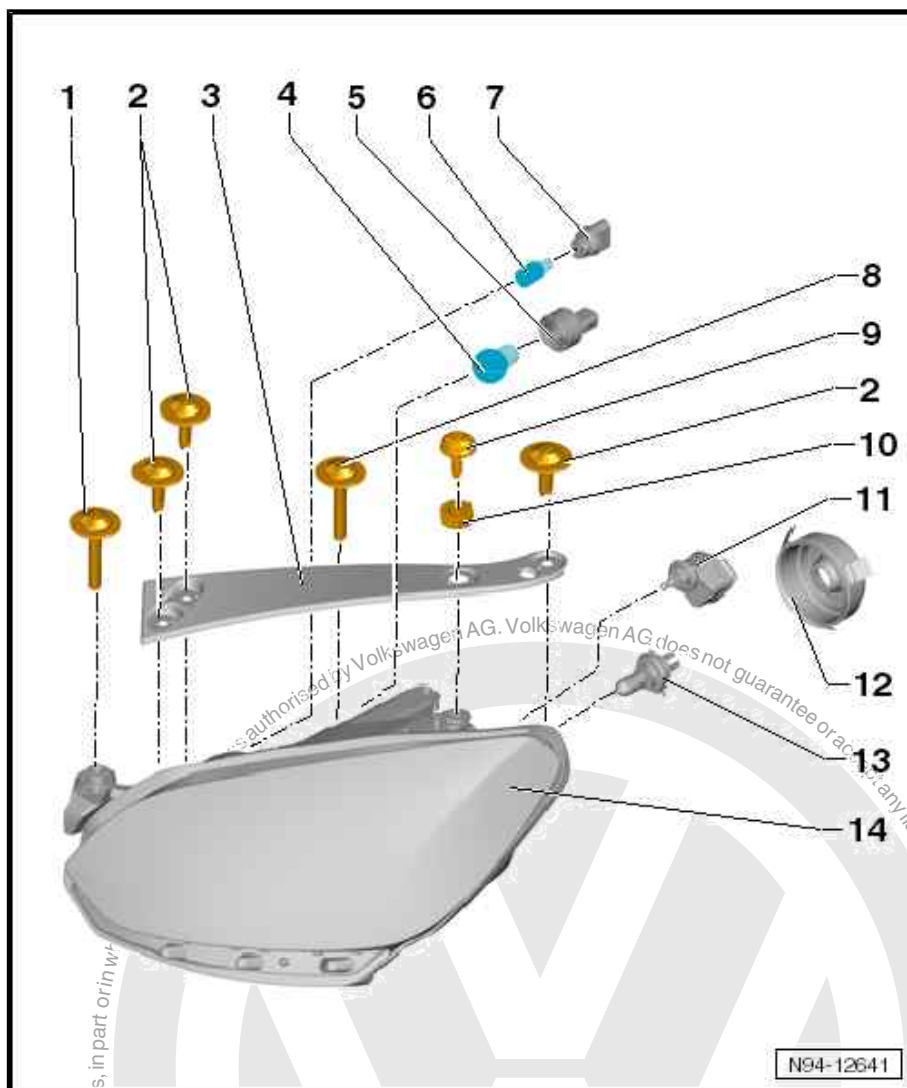



- ❑ Changing headlights over from driving on right to driving on left ⇒ [page 73](#)
- ❑ Changing headlights over from driving on left to driving on right ⇒ [page 74](#)

## 1.2 Removing and installing headlight

### Special tools and workshop equipment required

- ◆ Torque wrench - V.A.G 1331-

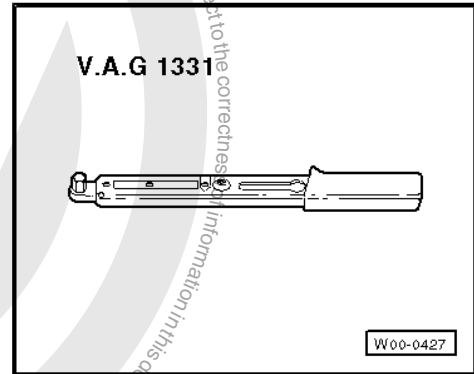

### Note

- ◆ *It is not necessary to disconnect the battery earth wire.*
- ◆ *The illustrations show removal and installation of the left headlight. The removal and installation of the right headlight follows the same principle.*
- ◆ *If a headlight is removed, it should always be adjusted following installation ⇒ Maintenance ; Booklet 35.1 ; Description of work .*

### Removing

- Switch off ignition and all electrical consumers, and withdraw ignition key.
- Remove front bumper cover ⇒ General body repairs, exterior; Rep. gr. 63 ; Front bumper; Assembly overview - front bumper cover .
- Release connectors -1-, -2-, -3- and -4- and pull them off.

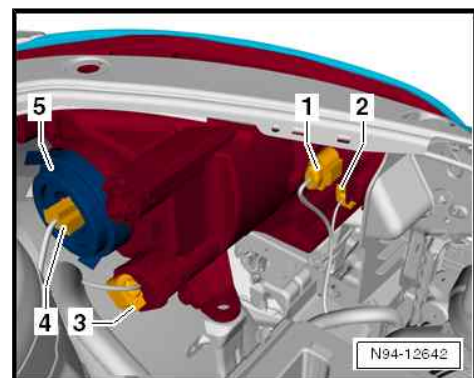



- Undo and remove inner bolt and upper bolt -arrows- and remove adapter -1- under the upper bolt.

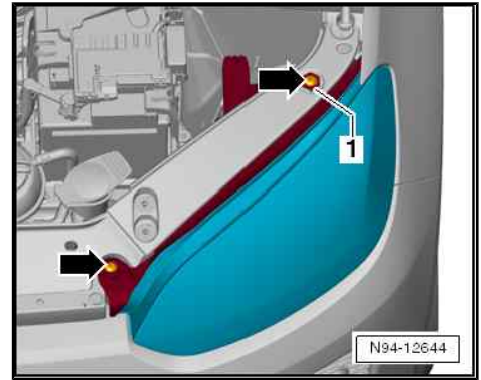

- Undo and remove rear bolt -arrow-.
- Remove headlight forwards out of body aperture.

### Installing

Install in the reverse order of removal, observing the following:

- Check installation position so that shut lines/gaps around headlight are even. If the shut lines/gaps around the headlight are uneven, the installation position must be adjusted => [page 67](#) .
- Check functions of headlight.
- Checking headlight settings and adjusting headlight if necessary "Maintenance manual" => Maintenance ; Booklet 35.1 ; Descriptions of work



### Specified torques

- ◆ => ["1.1 Assembly overview - headlight", page 64](#)

## 1.3 Adjusting headlights

Adjust headlights "Maintenance manual" => Maintenance ; Booklet 35.1 ; Descriptions of work .

## 1.4 Adjusting headlight installation position

### Special tools and workshop equipment required

- ◆ Torque wrench - V.A.G 1331-

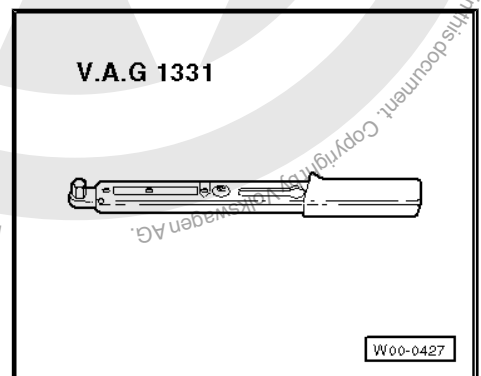

### Note

- ◆ *If the shut lines/gaps around the headlight are uneven after installation, the installation position must be adjusted.*
- ◆ *To adjust the installation position of the headlight, the front bumper does not have to be removed.*



- Switch off ignition and all electrical consumers, and withdraw ignition key.
- Loosen rear securing bolt -arrow-.

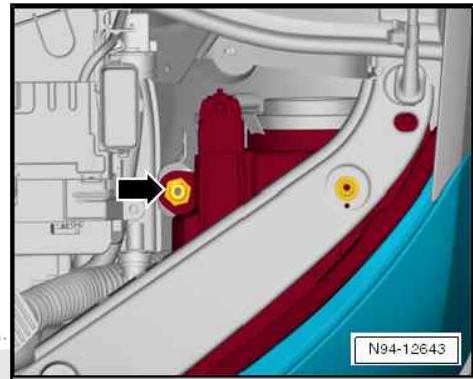

- Loosen inner and upper securing bolt -arrows-

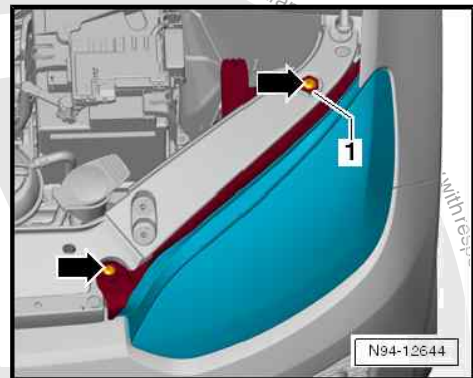

- Adjust shut lines/flushness to body by pushing in or pulling out alignment bush -arrow- on headlight.
- Tighten bolts.
- Check headlight installation position to ensure gaps are even; correct if necessary.
- Check functions of headlight.
- Checking headlight settings and adjusting headlight if necessary "Maintenance manual" ⇒ Maintenance ; Booklet 35.1 ; Descriptions of work

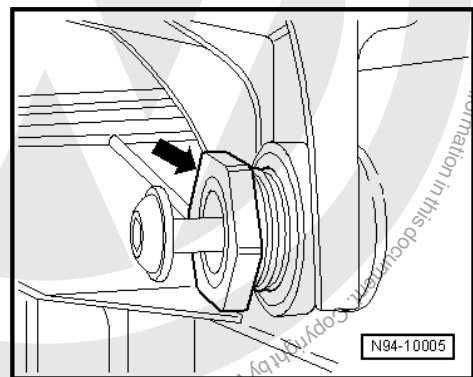

#### Specified torques

- ◆ ⇒ ["1.1 Assembly overview - headlight", page 64](#)

### 1.5 Removing and installing front turn signal bulb -M5- / -M7-



#### Caution

***Filament bulbs and gas discharge bulbs under pressure!***

***Danger of injury due to bursting filament lamps and gas discharge bulbs!***

- ◆ ***Remove filament bulbs and gas discharge bulbs carefully.***
- ◆ ***Always wear safety goggles and gloves when removing and installing filament bulbs or gas discharge bulbs!***
- ◆ ***Avoid contact with burst glass bulbs.***





**i** Note

*The removal and installation procedure is described for the left-hand side. The removal and installation procedure for the right-hand side is basically the same.*

**Removing**

- Switch off ignition and all electrical consumers, and withdraw ignition key.
- Release and pull off connector -2-.

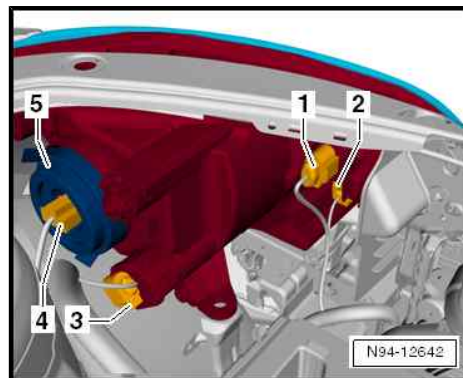

- Turn bulb holder -1- in -direction of arrow- as far as stop and remove it together with bulb for front turn signal towards the rear and out of headlight.

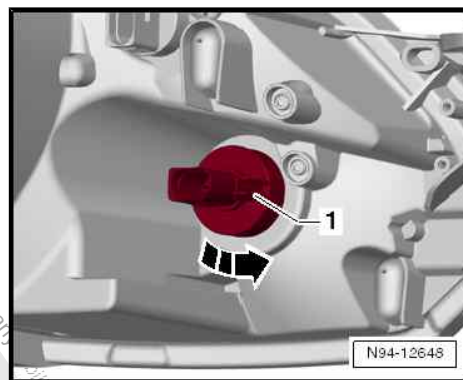





- Push front turn signal bulb -2- into holder and, at the same time, turn it in -direction of arrow- and pull it out of holder -1-.

Front turn signal bulb : 12V, PY21W

### Installing

Install in the reverse order of removal, observing the following:



#### Caution

##### *Risk of damage to the headlight.*

- ◆ *Do not touch the glass part of the bulb with bare fingers. Fingers leave traces of grease on the glass bulb, which evaporate when the bulb is switched on and cause the glass bulb to cloud over.*
- ◆ *Wear e.g. clean fabric gloves when inserting bulbs.*
- ◆ *Make sure the bulb holder is correctly seated when installing. The ingress of water will cause permanent damage to the headlight.*

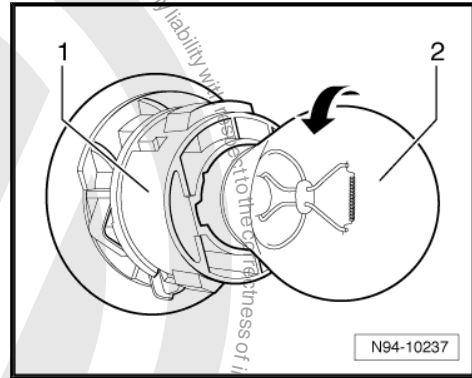

- Check functions of headlight.
- Check headlight adjustment, and readjust as necessary  
"Maintenance manual" ⇒ Maintenance ; Booklet 35.1 ; Descriptions of work .

## 1.6 Installing repair kit for headlight housing

⇒ ["1.6.1 Repairing upper fastening points", page 70](#)

⇒ ["1.6.2 Repairing inner retaining tab", page 71](#)

⇒ ["1.6.3 Repairing rear retaining tab", page 72](#)

### 1.6.1 Repairing upper fastening points

If the upper fastening point -1- is damaged or broken off, it can be repaired by installing a repair kit. There is therefore no need to replace the entire headlight.



#### Note

- ◆ *Check that there is no further damage to the headlight that would make installation of the repair kit unnecessary.*
- ◆ *The repair kits for the left and right headlights ⇒ ETKA (electronic parts catalogue) are different.*
- Switch off ignition and all electrical consumers, and withdraw ignition key.
- Remove headlight ⇒ [page 66](#) .

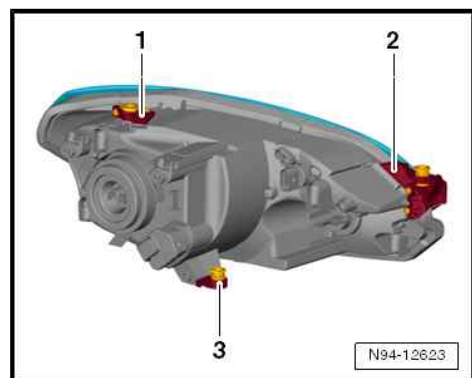



- Remove old fastening point -1- as far as necessary until new fastening point is lying evenly on the surface.

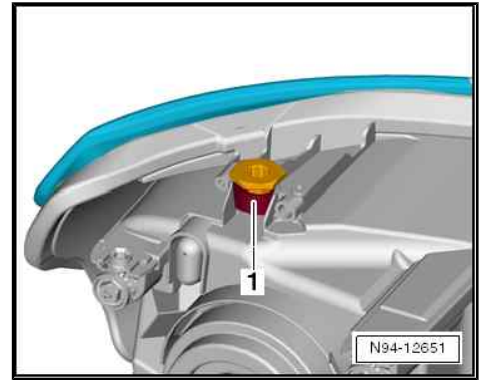

- Slot new retaining tab -B- onto base of old retaining tab on headlight, ensuring a positive fit, and tighten the two screws -A-.
- Install headlight => [page 66](#) .
- Check headlight settings and adjust if necessary “Maintenance Manual” => Maintenance ; Booklet 35.1 ; Descriptions of work

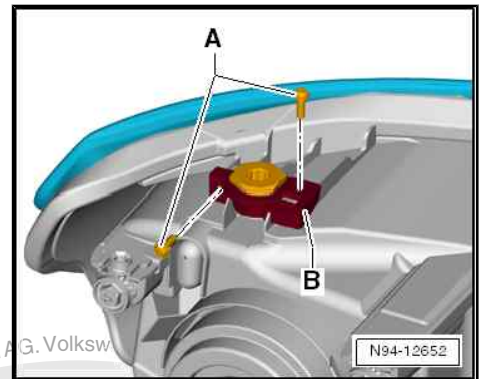

### Specified torques

Component	Specified torque
Securing bolts	1 Nm

## 1.6.2 Repairing inner retaining tab

If the inner retaining tab -2- is damaged or broken off, it can be repaired by installing a repair kit. There is therefore no need to replace the entire headlight.



### Note

- ◆ Check that there is no further damage to the headlight that would make installation of the repair kit unnecessary.
- ◆ The repair kits for the left and right headlights => ETKA (electronic parts catalogue) are different.
- Switch off ignition and all electrical consumers, and withdraw ignition key.
- Remove headlight => [page 66](#) .

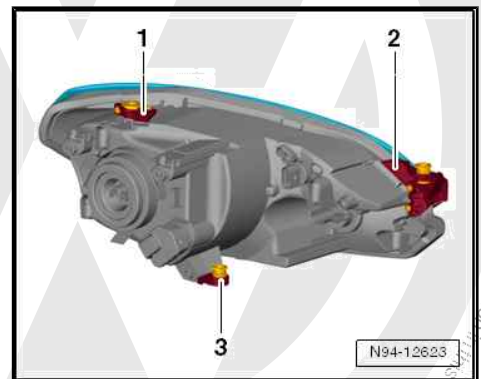



- Remove old retaining tab -1- as far as necessary until repair tab can be attached.

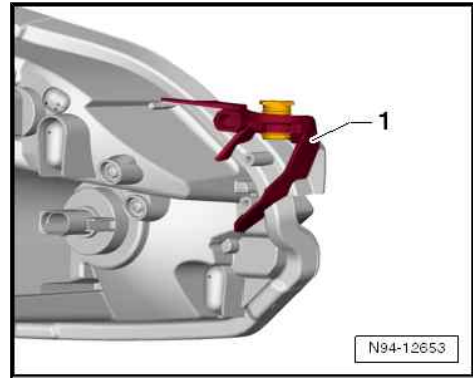

- Slot new retaining tab -B- onto base of old retaining tab on headlight, ensuring a positive fit, and tighten the two screws -A-.
- Install headlight ⇒ [page 66](#) .
- Check headlight settings and adjust if necessary "Maintenance Manual" ⇒ Maintenance ; Booklet 35.1 ; Descriptions of work

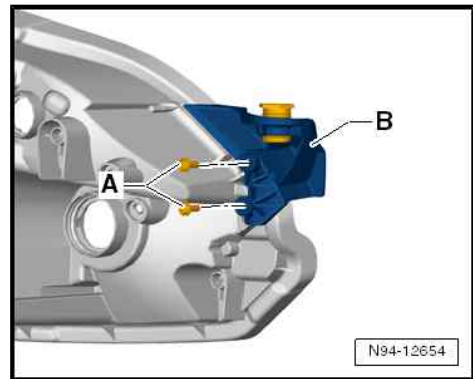

#### Specified torques

Component	Specified torque
Securing bolts	1 Nm

### 1.6.3 Repairing rear retaining tab

If the rear retaining tab -3- is damaged or broken off, it can be repaired by installing a repair kit. There is therefore no need to replace the entire headlight.



#### Note

- ◆ Check that there is no further damage to the headlight that would make installation of the repair kit unnecessary.
- ◆ The repair kits for the left and right headlights ⇒ ETKA (electronic parts catalogue) are different.
- Switch off ignition and all electrical consumers, and withdraw ignition key.
- Remove headlight ⇒ [page 66](#) .

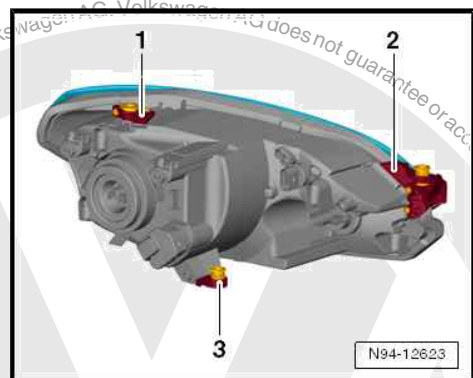



- Remove old retaining tab -1- as far as necessary until repair tab can be attached.

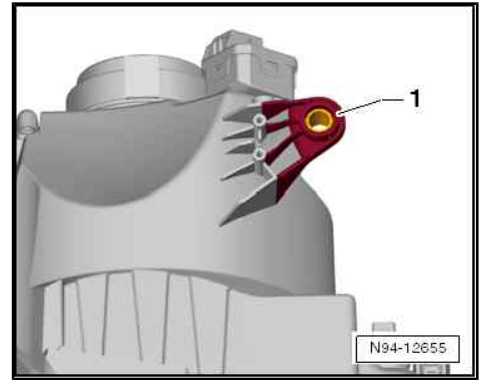

- Slot new retaining tab -B- onto base of old retaining tab on headlight, ensuring a positive fit, and tighten the two screws -A-.
- Install headlight => [page 66](#) .
- Check headlight settings and adjust if necessary "Maintenance Manual" => Maintenance ; Booklet 35.1 ; Descriptions of work

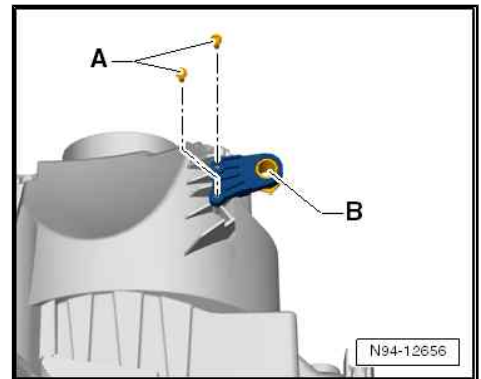

**Specified torques**

Component	Specified torque
Securing bolts	1 Nm

**1.7 Converting headlights from driving on right to driving on left**

**i Note**

- ◆ *To avoid dazzling oncoming traffic with the asymmetrical lights, both headlights should normally be converted relevant to the country (driving on the left or right) in which the vehicle is being driven.*
- ◆ *The asymmetrical dipped beam of the headlights in the up! remains below the legally prescribed dazzle values even if the headlight lens is masked.*
- ◆ *Converting the headlights temporarily for use in countries where vehicles drive on the other side of the road is therefore unnecessary.*



## 1.8 Converting headlights from driving on left to driving on right



### Note

- ◆ *To avoid dazzling oncoming traffic with the asymmetrical lights, both headlights should normally be converted relevant to the country (driving on the left or right) in which the vehicle is being driven.*
- ◆ *The asymmetrical dipped beam of the headlights in the up! remains below the legally prescribed dazzle values even if the headlight lens is masked.*
- ◆ *Converting the headlights temporarily for use in countries where vehicles drive on the other side of the road is therefore unnecessary.*

## 1.9 Removing and installing headlight range control motor -V48- / -V49-

Left headlight range control motor - V48- and right headlight range control motor - V49- are installed in the headlights in such a way that they can be replaced.



### Note

*The removal and installation procedure is described for the left-hand side. The removal and installation procedure for the right-hand side is basically the same.*

### Removing

- Remove headlight ⇒ [page 66](#) .
- Turn headlight range control motor -1- in -direction of arrow- as far as it will go.

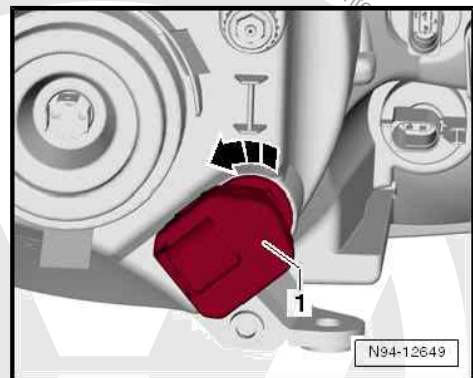





- Swing ball head of actuator -2- towards the right out of mounting in headlight -1- and remove actuator -3- from headlight housing.

### Installing

Install in the reverse order of removal, observing the following:



#### Caution

**Risk of damage to the headlight.**

- ◆ **Make sure the left headlight range control motor - V48- is correctly seated when installing. The ingress of water will cause permanent damage to the headlight.**

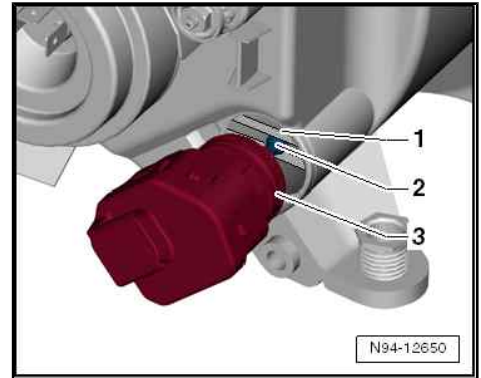

- Insert headlight range control motor into headlight in position it was in before it was removed.
- Swing ball head of headlight range control motor -2- into mounting in headlight -1- from the right, while pulling the reflector towards the rear.
- Insert the actuator -3- into its mounting on headlight housing and lock it in place by turning it clockwise as far as it will go.
- Check functions of headlight.
- Check headlight adjustment, and readjust if necessary  
⇒ Maintenance ; Booklet 35.1 ; Descriptions of work .

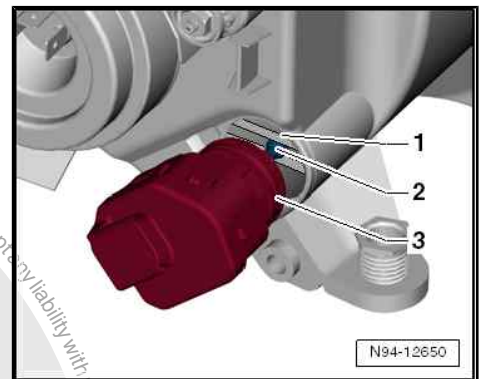

## 1.10 Removing and installing dipped beam bulb



#### Caution

**Filament bulbs and gas discharge bulbs under pressure!**

**Danger of injury due to bursting filament lamps and gas discharge bulbs!**

- ◆ **Remove filament bulbs and gas discharge bulbs carefully.**
- ◆ **Always wear safety goggles and gloves when removing and installing filament bulbs or gas discharge bulbs!**
- ◆ **Avoid contact with burst glass bulbs.**

The bulb for the dipped beam and main beam is a single component and functions as the bulb for the left dipped beam headlight - M29- and bulb for the left main beam headlight - M30- or, respectively, the bulb for the right dipped beam headlight - M31- and bulb for right main beam headlight - M32- .



### Note

- ◆ The illustrations show removal and installation of the bulb for dipped beam and main beam of left headlight. Removal and installation of the bulb for dipped beam and main beam of right headlight are analogous.
- ◆ The headlight does not need to be removed in order to install or remove bulb for dipped beam and main beam.

### Removing

- Switch off ignition and all electrical consumers, and withdraw ignition key.
- Release and pull off connector -4-.
- Pull cover -5- off rear of headlight.

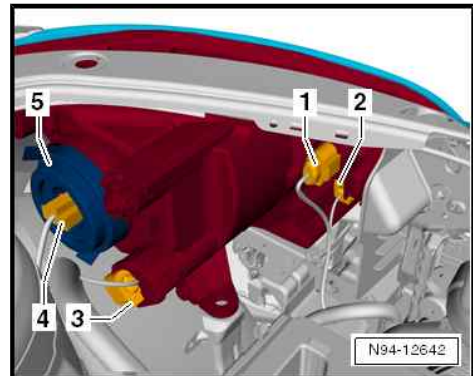

- Release retaining clip -2- and pull it to one side.
- Remove bulb for dipped beam and main beam -1- from reflector.

Bulb for dipped beam and main beam: H4 12V, 60/55W

### Installing

Install in the reverse order of removal, observing the following



### Caution

**Make sure cover cap is correctly seated when installing. The ingress of water will cause permanent damage to the headlight.**

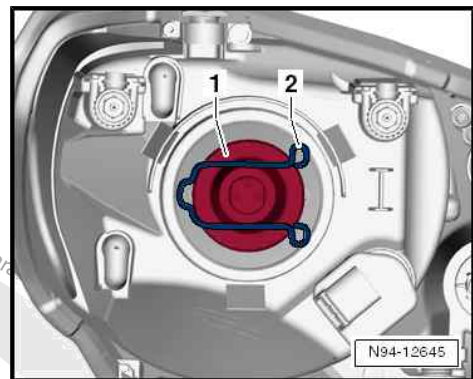

### Note

*Do not touch bulb glass when installing a bulb. Fingers leave traces of grease on the glass, which evaporate when the bulb is switched on and cause the glass to cloud over.*

- Check functions of headlight.
- Check headlight adjustment, and readjust as necessary  
"Maintenance manual" ⇒ Maintenance ; Booklet 35.1 ; Descriptions of work .





## 1.11 Removing and installing bulb for day-time running light/side light



### Caution

**Filament bulbs and gas discharge bulbs under pressure!**

**Danger of injury due to bursting filament lamps and gas discharge bulbs!**

- ◆ Remove filament bulbs and gas discharge bulbs carefully.
- ◆ Always wear safety goggles and gloves when removing and installing filament bulbs or gas discharge bulbs!
- ◆ Avoid contact with burst glass bulbs.



### Note

The illustrations show removal and installation of the bulb for side light/daytime running light on left. Removal and installation of bulb for side light/daytime running light on right are analogous.

### Removing

- Switch off ignition and all electrical consumers, and withdraw ignition key.
- Release and pull off connector -1-.

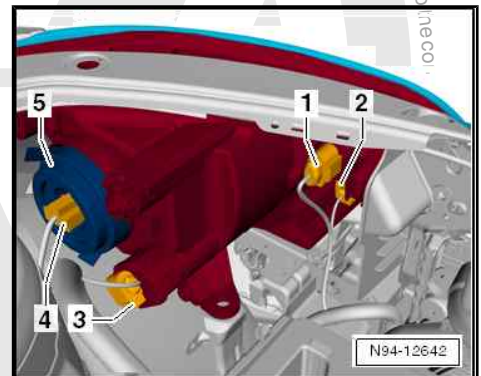

- Turn bulb holder -1- in -direction of arrow- as far as stop and remove it together with bulb for side light/daytime running light towards the rear and out of headlight.

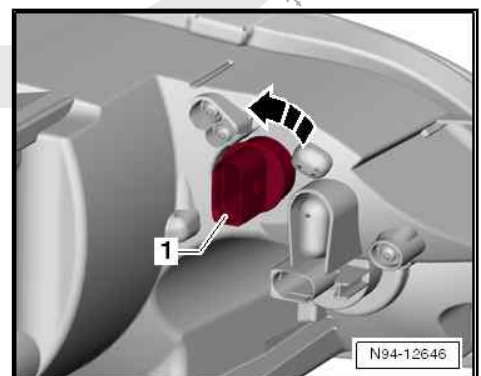



- Pull bulb for side light/daytime running light -2- in a straight line out bulb holder -1-.

Bulb for side light/daytime running light: 12V, 21/5W

### Installing

Install in the reverse order of removal, observing the following:



#### Caution

**Risk of damage to the headlight.**

- ◆ **Do not touch the glass part of the bulb with bare fingers. Fingers leave traces of grease on the glass bulb, which evaporate when the bulb is switched on and cause the glass bulb to cloud over.**
- ◆ **Wear e.g. clean fabric gloves when inserting bulbs.**
- ◆ **Make sure the bulb holder is correctly seated when installing. The ingress of water will cause permanent damage to the headlight.**

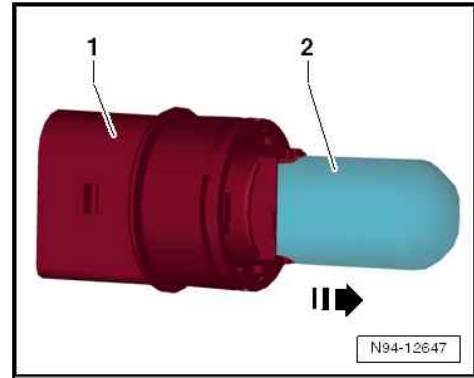

- Check functions of headlight.
- Check headlight adjustment, and readjust as necessary  
"Maintenance manual" ⇒ Maintenance ; Booklet 35.1 ; Descriptions of work.



## 2 Fog lights

⇒ [“2.1 Assembly overview - fog lights”, page 79](#)

⇒ [“2.2 Removing and installing fog light”, page 79](#)

⇒ [“2.3 Removing and installing fog light bulb”, page 80](#)

⇒ [“2.4 Adjusting fog lights”, page 81](#)

### 2.1 Assembly overview - fog lights

#### 1 - Securing bolts

- ❑ Specified torque:  
1.5 Nm

#### 2 - Front bumper cover

#### 3 - Fog light housing

- ❑ Removing and installing  
⇒ [page 79](#)

#### 4 - Left fog light bulb - L22- or right fog light bulb - L23-

- ❑ Bulb HB4 12V, 51 W
- ❑ Removing and installing  
⇒ [page 80](#)

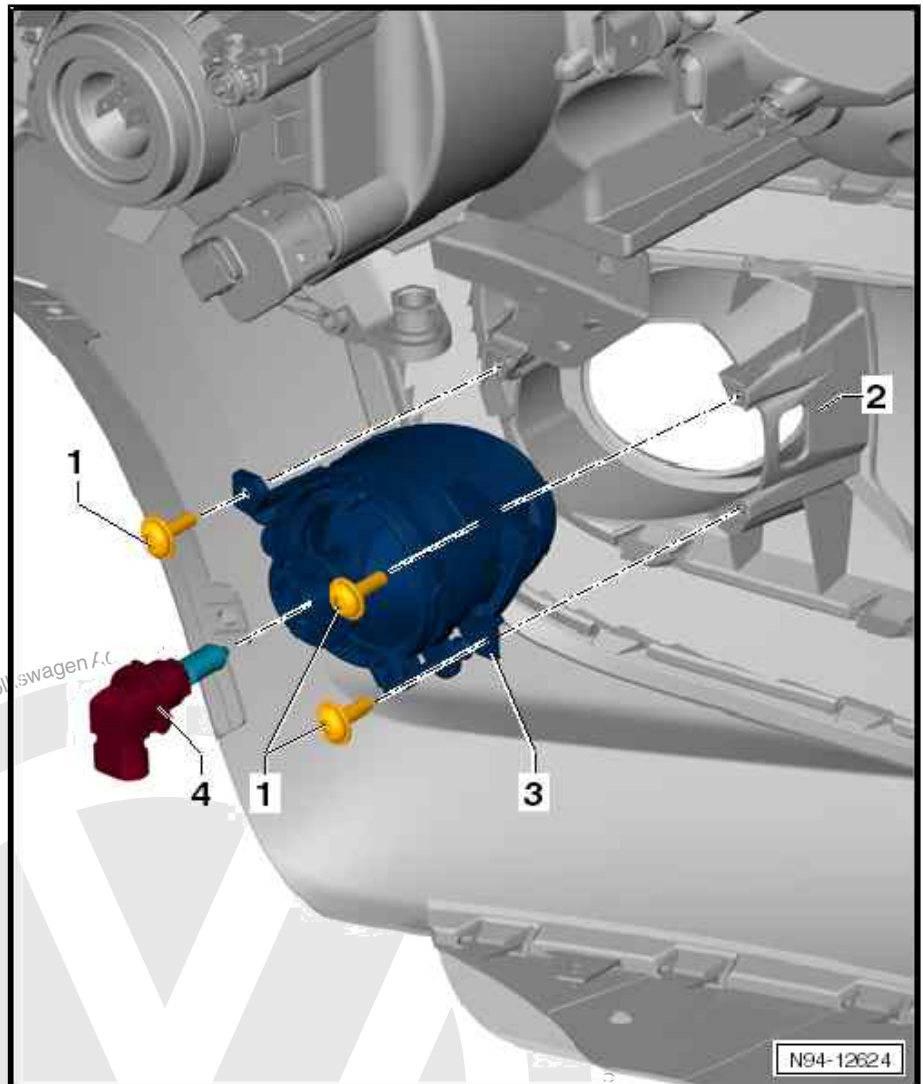

### 2.2 Removing and installing fog light



#### Note

*The removal and installation procedure is described for the left-hand side. The removal and installation procedure for the right-hand side is basically the same.*



## Removing

- Switch off ignition and all electrical consumers, and withdraw ignition key.
- Detach front area of liner in front wheel housing to gain access to back of fog light ⇒ General body repairs, exterior; Rep. gr. 66 ; Wheel housing liner: Assembly overview - front wheel housing liner .
- Release and pull off connector -1-.



### Note

*When the fog light is being removed, it may be necessary to push the flexible filling pipe of the washer fluid reservoir to one side a little in order to gain access to all the securing screws.*

- Undo screws -arrows- and remove fog light housing -2- from front bumper cover -3-.

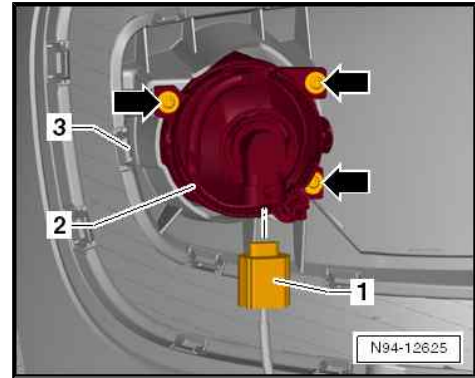

## Installing

Install in the reverse order of removal, observing the following:

- Check function of fog light.
- Check fog light settings, and adjust if necessary ⇒ Maintenance ; Booklet ; Descriptions of work .

## Specified torques

- ◆ ⇒ ["2.1 Assembly overview - fog lights", page 79](#)

## 2.3 Removing and installing fog light bulb



### Note

*The removal and installation procedure is described for the left-hand side. The removal and installation procedure for the right-hand side is basically the same.*

## Removing

- Switch off ignition and all electrical consumers, and withdraw ignition key.
- Detach front area of liner in front wheel housing to gain access to back of fog light ⇒ General body repairs, exterior; Rep. gr. 66 ; Wheel housing liner: Assembly overview - front wheel housing liner .



- Release and pull off connector -1-.
- Turn bulb holder -2- together with fog light bulb in -direction of arrow- and remove from fog light housing -3-.



**Note**

*The fog light bulb is permanently attached to the bulb holder and cannot be renewed separately.*

Fog light bulb : HB4 12 V, 51 W

**Installing**

Install in the reverse order of removal, observing the following:



**Caution**

**Risk of damage to the headlight.**

- ◆ **Do not touch the glass part of the bulb with bare fingers. Fingers leave traces of grease on the glass bulb, which evaporate when the bulb is switched on and cause the glass bulb to cloud over.**
- ◆ **Wear e.g. clean fabric gloves when inserting bulbs.**
- ◆ **Make sure the bulb holder is correctly seated when installing. The ingress of water will cause permanent damage to the headlight.**

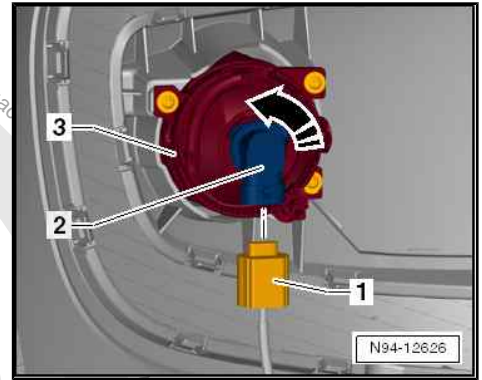

- Check function of headlight.
- Adjusting fog lights => [page 81](#) .

## 2.4 Adjusting fog lights

Adjusting fog lights: "Maintenance manual" => Maintenance ; Booklet 35.1 ; Descriptions of work .



### 3 Turn signal repeater

⇒ "3.1 Removing and installing turn signal repeater", page 82

⇒ "3.2 Removing and installing turn signal light bulb", page 83

#### 3.1 Removing and installing turn signal repeater

The turn signal lights are built into the front wings on the left and right.



#### Note

The removal and installation procedure is described for the left hand side. The removal and installation procedure for the right hand side is basically the same.

#### Removing

- Switch off ignition and all electrical consumers, and withdraw ignition key.



#### Caution

*Release of side turn signals is only possible in one direction. Great care must be taken when signal lights are being removed as there is no way of determining which side of the turn signal light the fixed anchor point -1- and the spring clip -2- are on before the signal light is removed. If an attempt is made to lever the spring clip side out with force, there is a risk of damaging the turn signal and the paintwork of the body.*

- Mask off the painted area on both sides of the turn signal.
- Carefully press the turn signal light in the direction of the spring clip -arrow- and, starting with the fixed anchor point, pull it out of the body.
- Pull holder together with glass base bulb -1- off bulb housing -2- and remove bulb housing.

#### Installing

Install in the reverse order of removal, observing the following.

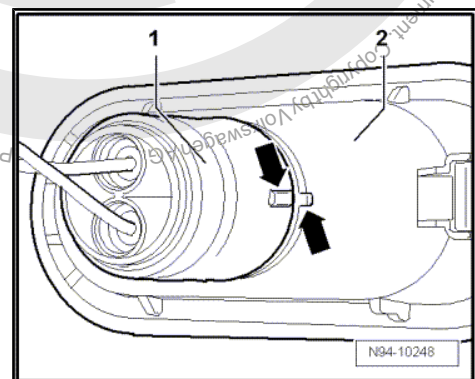
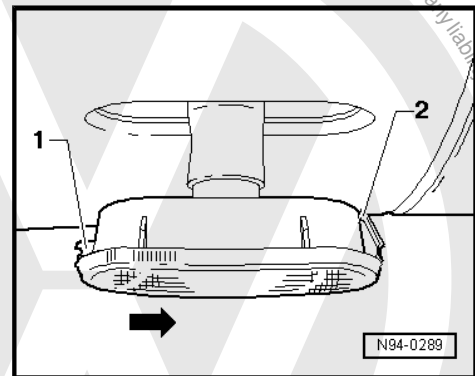





- Fit holder together with glass base bulb -1- onto bulb housing -2- so that retaining lugs -arrows- are opposite one another.

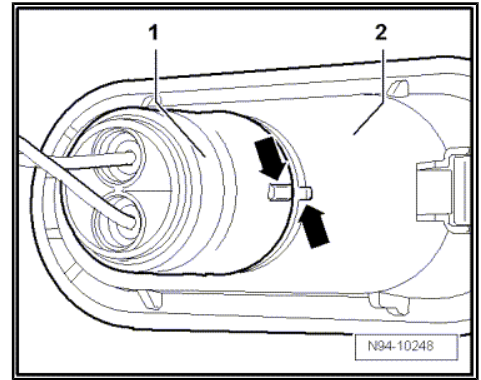

- Insert bulb housing into body, starting with the spring clip -2-, press in direction of spring clip -arrow- and secure it in body with fixed anchor point -1-.
- Following installation, check whether turn signal light is functioning correctly.

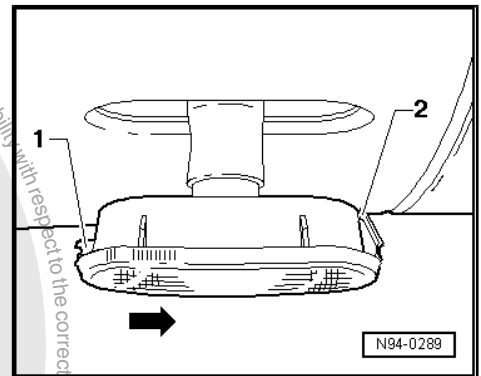

### 3.2 Removing and installing turn signal light bulb



#### Note

The removal and installation procedure is described for the left-hand side. The removal and installation procedure for the right-hand side is basically the same.

#### Removing

- Switch off ignition and all electrical consumers, and withdraw ignition key.
- Remove turn signal light ⇒ [page 82](#) .
- Pull glass-base bulb -1- in a straight line out of bulb holder -2-.

Bulb for turn signal : 12 V, W 5 W

#### Installing

Install in reverse order of removal.

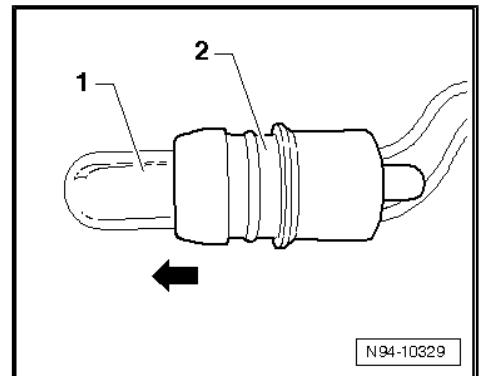



## 4 Tail lights

⇒ [“4.1 Assembly overview - tail lights in body”, page 84](#)

⇒ [“4.2 Removing and installing bulb carrier”, page 85](#)

⇒ [“4.3 Removing and installing tail light bulb M2 / M4 ”, page 85](#)

⇒ [“4.4 Removing and installing tail light”, page 86](#)

⇒ [“4.5 Removing and installing rear fog light bulb L46 / L47 ”, page 87](#)

⇒ [“4.6 Removing and installing brake and tail light bulb M21 / M22 ”, page 88](#)

⇒ [“4.7 Removing and installing reversing light bulb”, page 88](#)

⇒ [“4.8 Removing and installing turn signal bulb”, page 89](#)

### 4.1 Assembly overview - tail lights in body

1 - Left tail light - MX3- or right tail light - MX4- in side panel

- ❑ Removing and installing  
⇒ [page 86](#)

2 - Tail light bulb carrier in side panel

- ❑ Removing and installing  
⇒ [page 85](#)

3 - Securing nut

- ❑ Specified torque: screw on by hand as far as stop (max. 2 Nm)

4 - Left brake and tail light bulb - M21- or right brake and tail light bulb - M22-

- ❑ Filament bulb  
12V, P21/4W

5 - Rear left turn signal bulb - M6- or rear right turn signal bulb - M8-

- ❑ Bulb 12V, RY10W

6 - Left tail light bulb - M4- or right tail light bulb - M2-

- ❑ Filament bulb  
12V, P21/4W

7 - Left reverse light bulb - M16- or right reverse light bulb - M17-

- ❑ Bulb 12 V, R10W

8 - Rear left fog light bulb - L46- or rear right fog light bulb - L47-

- ❑ The rear fog light bulb with its 4-watt spiral also functions as a tail light bulb.
- ❑ Filament bulb 12V, P21/4W

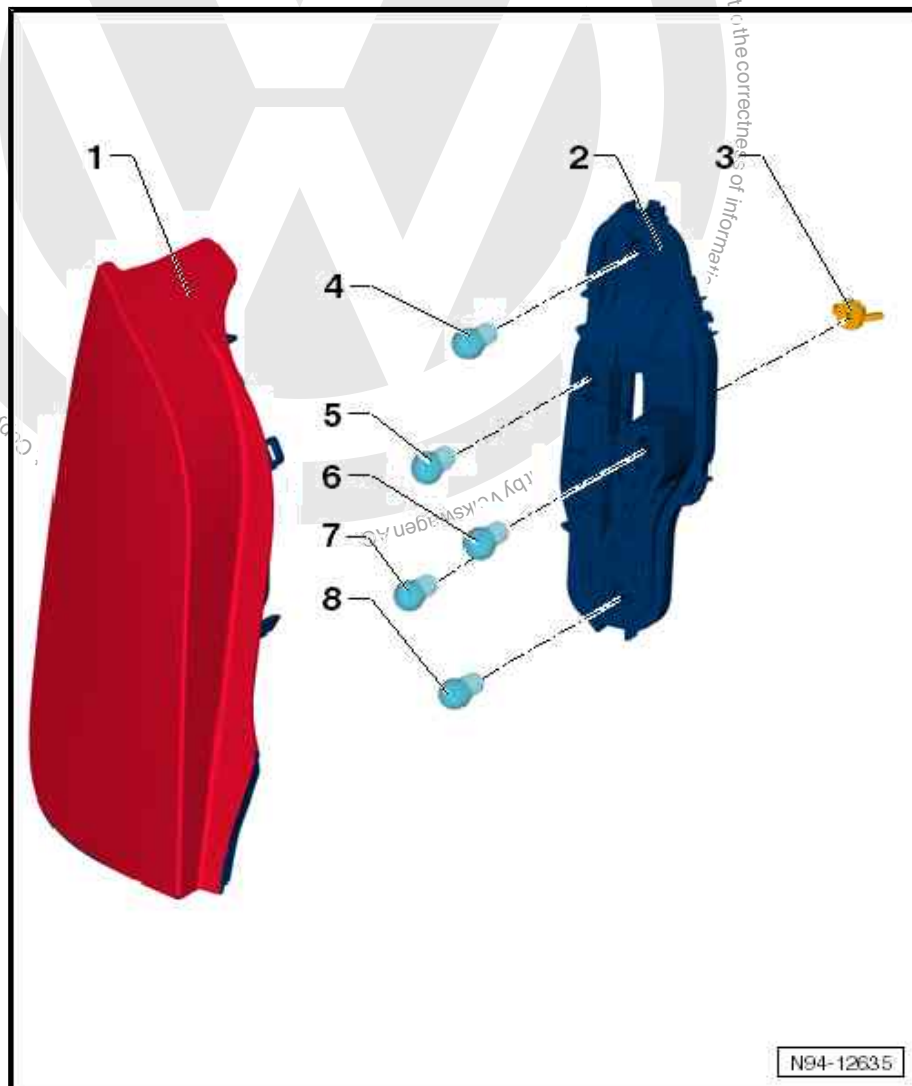



## 4.2 Removing and installing bulb carrier



Note

The removal and installation procedure is described for the left-hand side. The removal and installation procedure for the right-hand side is basically the same.

### Removing

- Switch off ignition and all electrical consumers, and withdraw ignition key.
- Remove tail light in side panel ⇒ [page 86](#) .
- Push catches -arrows- outwards and remove bulb carrier -1- from tail light housing.

### Installing

Install in the reverse order of removal, observing the following:



Note

When installing bulb carrier, make sure that all catches engage audibly.

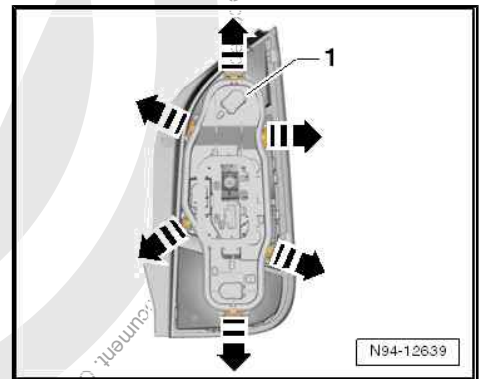

## 4.3 Removing and installing tail light bulb - M2- / -M4-



Note

The removal and installation procedure is described for the left-hand side. The removal and installation procedure for the right-hand side is basically the same.

### Removing

- Switch off ignition and all electrical consumers, and withdraw ignition key.
- Remove tail light bulb carrier in side panel ⇒ [page 85](#) .
- Push rear light bulb -2- into holder, turn anti-clockwise and pull upwards out of bulb carrier -6-.

Bulb for rear light : filament bulb 12V, P21/4W

### Installing

Install in reverse order of removal.

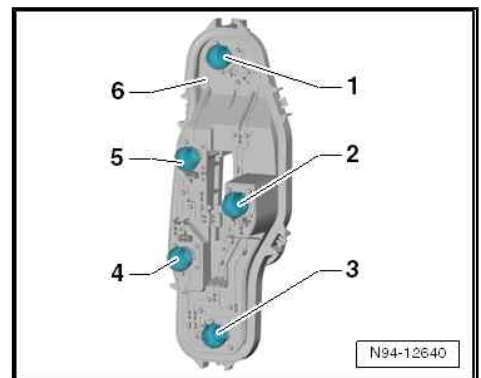



## 4.4 Removing and installing tail light



### Note

*The removal and installation procedure is described for the left-hand side. The removal and installation procedure for the right-hand side is basically the same.*

### Removing

- Switch off ignition and all electrical consumers, and withdraw ignition key.
- Remove service flap -1- from side panel trim in luggage compartment.

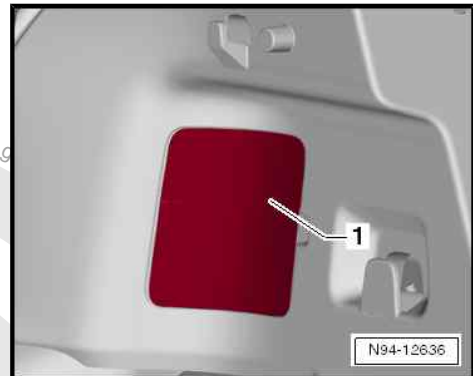

- Undo and remove nut -1- and remove tail light backwards out of body aperture in side panel, taking connected wiring lengths into consideration.

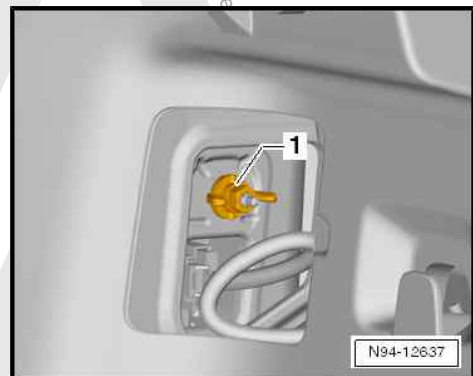



- Release and pull off connector -arrow- and then remove tail light.

**Installing**

Install in the reverse order of removal, observing the following:

 **Caution**

*Risk of wiring damage.*

*The wiring harness for the tail lights could become trapped when installing.*

*Once the electrical connector has been fitted, the wiring harness must be fed through the aperture to the inside without it getting trapped.*

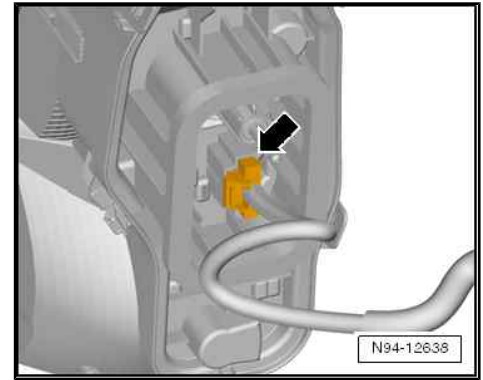

- Screw on securing nut by hand as far as stop.
- When installation is complete, check gap/shut lines to body and functions of tail light.

**Specified torques**

- ◆ ["4.1 Assembly overview - tail lights in body", page 84](#)

**4.5 Removing and installing rear fog light bulb -L46- / -L47-**

 **Note**

*The removal and installation procedure is described for the left-hand side. The removal and installation procedure for the right-hand side is basically the same.*

**Removing**

- Switch off ignition and all electrical consumers, and withdraw ignition key.
- Remove tail light bulb carrier in side panel ⇒ [page 85](#)
- Push rear fog light bulb -3- into holder, turn anti-clockwise and pull upwards out of bulb carrier -6-.

Bulb for rear fog light : filament bulb 12V, P21/4W

**Installing**

Install in reverse order of removal.

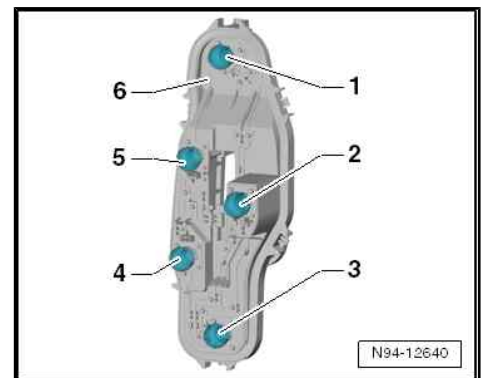



## 4.6 Removing and installing brake and tail light bulb -M21- / -M22-



### Note

The removal and installation procedure is described for the left-hand side. The removal and installation procedure for the right-hand side is basically the same.

### Removing

- Switch off ignition and all electrical consumers, and withdraw ignition key.
- Remove tail light bulb carrier in side panel ⇒ [page 85](#) .
- Push bulb for brake light and tail light -1- into holder, turn anti-clockwise and pull upwards out of bulb carrier -6-.

Bulb for brake light and tail light : filament bulb 12V, P21/4W

### Installing

Install in reverse order of removal.

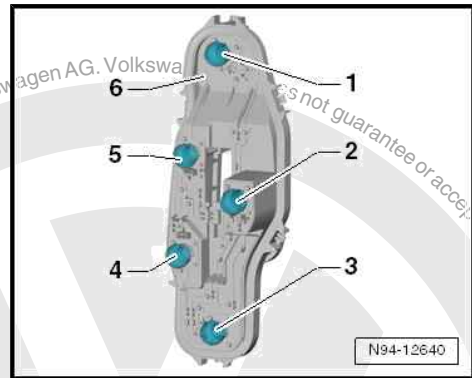

## 4.7 Removing and installing reversing light bulb



### Note

The removal and installation procedure is described for the left-hand side. The removal and installation procedure for the right-hand side is basically the same.

### Removing

- Switch off ignition and all electrical consumers, and withdraw ignition key.
- Remove tail light bulb carrier in side panel ⇒ [page 85](#) .
- Push reversing light bulb -4- into holder, turn anti-clockwise and pull upwards out of bulb carrier -6-.

Reversing light bulb : filament bulb 12V, R10W

### Installing

Install in reverse order of removal.

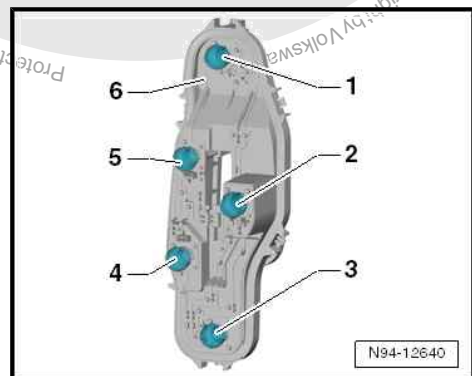



## 4.8 Removing and installing turn signal bulb

### Note

*The removal and installation procedure is described for the left-hand side. The removal and installation procedure for the right-hand side is basically the same.*

### Removing

- Switch off ignition and all electrical consumers, and withdraw ignition key.
- Remove tail light bulb carrier in side panel ⇒ [page 85](#) .
- Push turn signal bulb -5- into holder, turn anti-clockwise and pull upwards out of bulb carrier -6-.

Turn signal bulb : filament bulb 12V, RY10W

### Installing

Install in reverse order of removal.

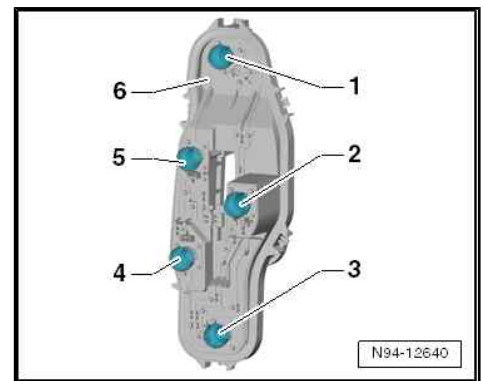



## 5 High-level brake light

⇒ "5.1 Removing and installing additional brake light",  
page 90

### 5.1 Removing and installing additional brake light



#### Caution

*When removing and installing components that are in view (switches, covers, trim and so on), mask off areas in which tools (assembly wedge - T10039/1-, screwdriver) are used to lever out those components using commercially available masking tape.*

#### Special tools and workshop equipment required

- ◆ Plastic wedge - T10039/1-

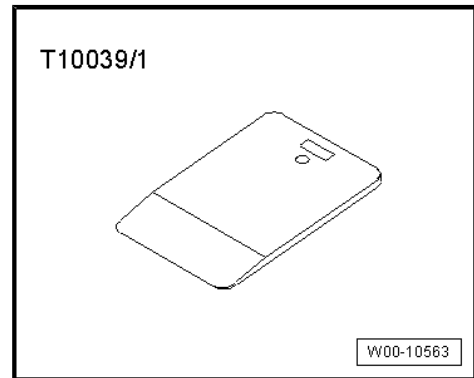

#### Removing

- Switch off ignition and all electrical consumers, and withdraw ignition key.

Attach a strip of commercially available adhesive tape -1- to the area of the rear lid above the bulb for the high-level brake light.

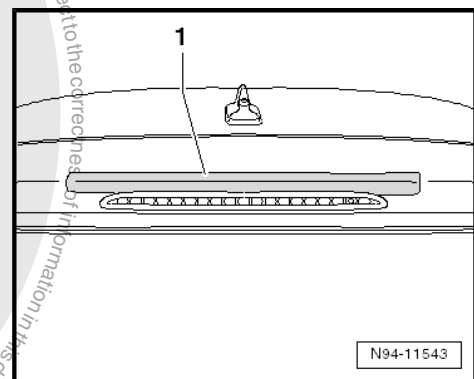





- Insert assembly wedge - T10039/1- -1- at top between bulb for high-level brake light - M25- -2- and rear lid.

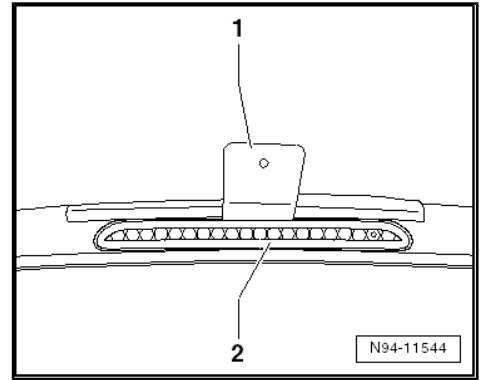

- Release catch of bulb for high-level brake light - M25- by pushing assembly wedge in direction of front of vehicle.
- Take high-level brake light bulb - M25- out of rear lid, taking connected wiring lengths into account.

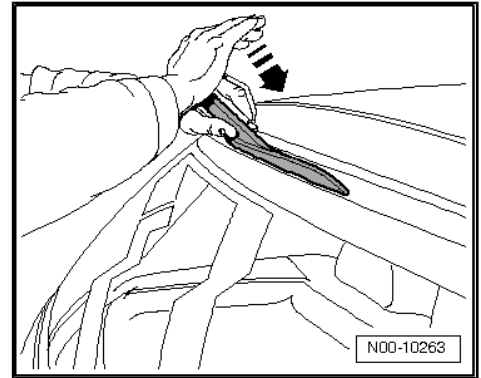



- Pull out hose lock -arrow- and pull off hose connection -1- from high-level brake light bulb - M25- .
- Release and pull connector -2- off and remove high-level brake light bulb - M25- .

### Installing

Install in the reverse order of removal observing the following:



#### Note

- ◆ *Failure of light-emitting diodes in high-level brake lights*
- ◆ *The individual LEDs (light-emitting diodes) in the high-level brake light are located together in groups of 3 LEDs and are supplied with current in groups.*
- ◆ *Due to the failure of individual LEDs, the intact LEDs of the group in question are placed under increased strain and it must therefore be anticipated that further LED will soon fail as well.*
- ◆ *If an LED group (3 individual light-emitting diodes) fails, the legal light values of the ECE ruling (ECE = Economic Commission for Europe) are still complied with.*
- ◆ *If more than 3 individual LEDs fail, the legal light values of the ECE ruling (ECE = Economic Commission for Europe) are no longer complied with and the lamp for the high-level brake light must be replaced.*

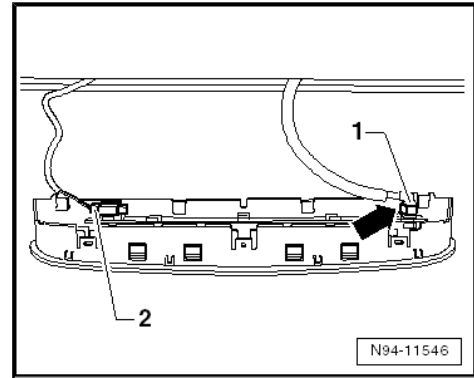

#### Note

*When installing high-level brake light bulb - M25- , ensure seal is seated correctly. Make sure that the seal is undamaged and that no loops are formed.*

- Push on connector and engage.
- Starting at the lower edge, insert bulb for high-level brake light into rear lid, making sure it engages securely.
- Check functioning of high-level brake light lamp - M25- .



## 6 Number plate light

⇒ [“6.1 Removing and installing number plate light X4 / X5”, page 93](#)

⇒ [“6.2 Removing and installing bulb for number plate light X4 / X5”, page 93](#)

### 6.1 Removing and installing number plate light - X4- / -X5-



#### Note

*When removing and installing components that are in view (switches, covers, trim and so on), mask off areas in which tools (assembly wedge - T10039/1-, screwdriver) are used to lever out those components using commercially available masking tape.*

#### Removing

- Switch off ignition and all electrical consumers, and withdraw ignition key.
- Lever left-hand side of number plate light -arrow- out of bumper cover, using a screwdriver.
- Pull number plate light out of bumper cover, taking connected wire lengths into account.

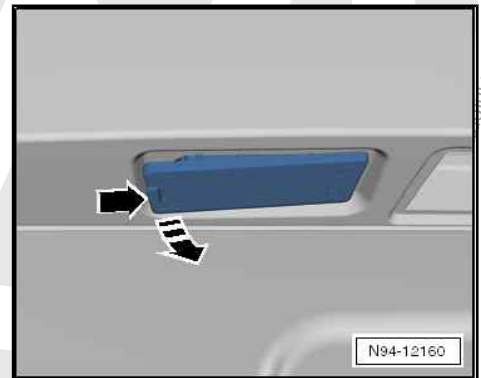

- Turn bulb holder -1- in -direction of arrow- and pull out.
- Remove number plate light.

#### Installing

Install in the reverse order of removal observing the following:

- Insert number plate light into bumper cover, starting at right-hand side, and then push it in on the left-hand side, making sure it is latched in place securely.
- Check function of number plate light.

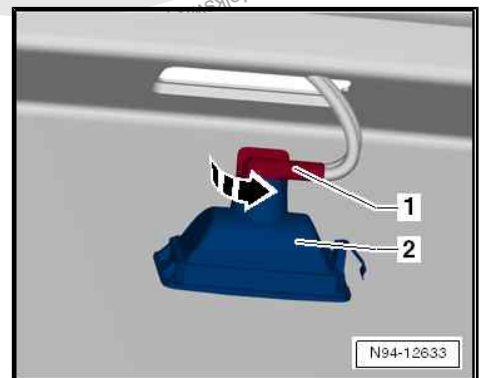

### 6.2 Removing and installing bulb for number plate light - X4- / -X5-

#### Removing

- Switch off ignition and all electrical consumers, and withdraw ignition key.
- Remove number plate light - X- ⇒ [page 93](#) .



- Pull glass base bulb -2- in -direction of arrow- out of bulb holder  
-1- in a straight line.

Bulb for number plate light -X- : glass-base bulb 12 V, 5 W.

### Installing

Installation is carried out in the reverse sequence of removal.

- Check function of number plate light.

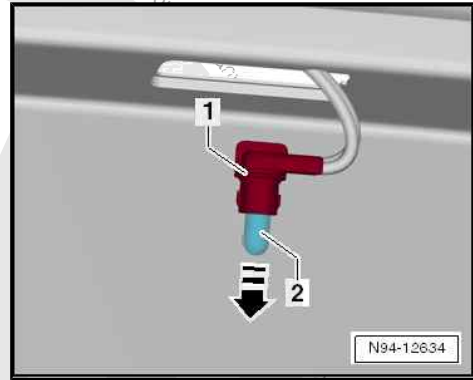



## 7 Steering column switch module

### 7.1 Steering column switch module ▶ 10.2013

⇒ [“7.1.1 Removing and installing steering column switch module”, page 95](#)

⇒ [“7.1.2 Removing and installing airbag coil connector and return ring with slip ring F138”, page 97](#)

⇒ [“7.1.3 Removing and installing steering angle sender G85”, page 98](#)

⇒ [“7.1.4 Removing and installing ignition/starter switch”, page 98](#)

⇒ [“7.1.5 Checking ignition/starter switch”, page 98](#)

⇒ [“7.1.6 Removing and installing lock cylinder”, page 99](#)

⇒ [“7.1.7 Removing and installing steering lock housing”, page 100](#)

#### 7.1.1 Removing and installing steering column switch module

##### Special tools and workshop equipment required

- ◆ Torque wrench - V.A.G 1331-

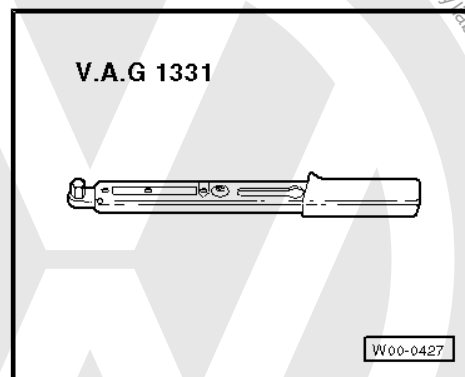

- ◆ Torque wrench - V.A.G 1783-

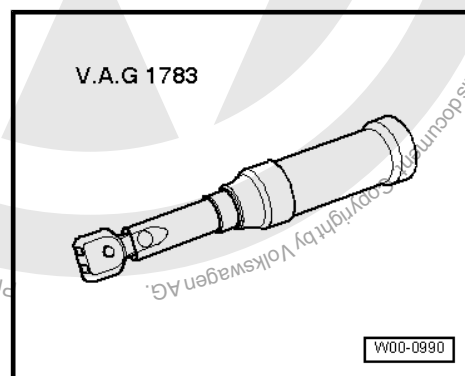

##### General description:

The following equipment-specific components are integrated into the steering column switch:

- ◆ Turn signal switch - E2-
- ◆ Washer pump switch (automatic wash/wipe and headlight washer system) - E44-



- ◆ Headlight dipper and flasher switch - E4-
- ◆ Parking light switch - E19-
- ◆ Intermittent wiper switch - E22-
- ◆ Rear window wiper switch - E34-
- ◆ Intermittent wiper regulator - E38-
- ◆ Cruise control system switch - E45-
- ◆ Cruise control system (CCS) SET button - E227-



#### Note

*The entire steering column combination switch is to be renewed if one of the above components is defective.*

The airbag coil connector and return spring with slip ring - F138- are attached to the steering column switch and are to be replaced separately ⇒ General body repairs, interior; Rep. gr. 69 ; Driver side airbag; Removing and installing return spring with slip ring (coil connector) .

#### Fault detection and fault display:

The following components feature self-diagnosis capability:

- ◆ Turn signal switch - E2-
- ◆ Washer pump switch (automatic wash/wipe and headlight washer system) - E44-
- ◆ Cruise control system switch - E45-
- ◆ Intermittent wiper switch - E22-
- ◆ Steering angle sender - G85-



#### Note

- ◆ *For removal and installation of the airbag coil connector and return spring with slip ring - F138- or the steering column switch, the steering wheel must be in the "centre position" (wheels in "straight ahead position").*
- ◆ *The airbag coil connector and return ring with slip ring - F138- is not to be moved out of position.*
- ◆ *If the steering angle sender - G85- is integrated into the airbag coil connector and return spring with slip ring - F138- (vehicles with EPS (electric power steering) and ESP), the steering angle sender must be reset after work has been done on the steering column switch.*
- ◆ *If the steering angle sender - G85- is integrated into the airbag coil connector and return spring with slip ring - F138- , there is a yellow marking to indicate the centre position.*

#### Removing

- Disconnect battery ⇒ [page 5](#) .
- Turn steering wheel to "centre position" (wheels in "straight ahead position").
- Remove steering wheel ⇒ Running gear, axles, steering; Rep. gr. 48 ; Steering wheel; Assembly overview - steering wheel .



- Move the steering column to its lowest position by means of the steering column adjustment feature and lock it in place with the locking lever.
- Remove steering column trim => General body repairs, interior; Rep. gr. 68 ; Compartments/covers; Assembly overview - steering column trim .
- Release securing bolt -arrow- of steering column switch -1-.

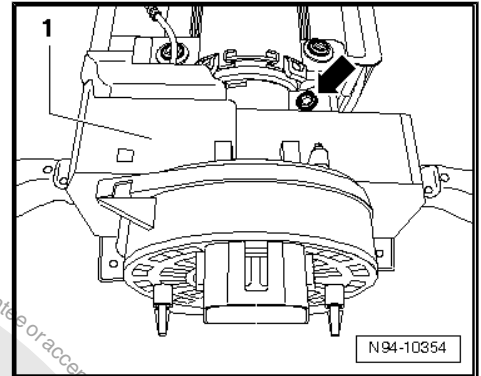

- Pull safety latch -2- upwards in -direction of arrow B- and pull connector -1- off steering column switch -3-.
- Pull steering column switch -3- towards the rear and off steering column.

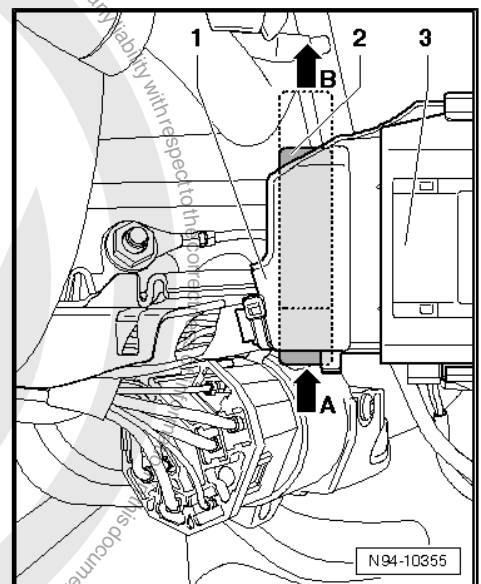

**Installing**

Install in the reverse order of removal observing the following:

- If the coil connector has been moved out of centre position accidentally, the centre position can be redetermined by turning the coil connector from one stop to another and counting the number of turns.
- If the steering angle sender - G85- is integrated into the airbag coil connector and return spring with slip ring - F138- (vehicles with EPS (electric power steering) and ESP), reset the steering angle sender.

**7.1.2 Removing and installing airbag coil connector and return ring with slip ring - F138-**

**Removing**

- Disconnect battery => [page 5](#) .
- Turn steering wheel to "centre position" (wheels in "straight ahead position").
- Remove steering wheel => Running gear, axles, steering; Rep. gr. 48 ; Steering wheel; Assembly overview - steering wheel .
- Move the steering column to its lowest position by means of the steering column adjustment feature and lock it in place with the locking lever.
- Remove steering column trim => General body repairs, interior; Rep. gr. 68 ; Compartments/covers; Assembly overview - steering column trim .





### 7.1.3 Removing and installing steering angle sender - G85-



#### Note

The steering angle sender is fitted depending on the equipment scope.

The steering angle sender - G85- is integrated in the coil connector. Thus, these parts form one component.

- Remove steering angle sender - G85- . To do this, refer to "Removing and installing airbag coil connector and return ring with slip ring - F138- " ⇒ [page 97](#) .

### 7.1.4 Removing and installing ignition/starter switch

#### Removing

- Disconnect battery ⇒ [page 5](#) .
- Remove steering column combination switch - E595- ⇒ [page 95](#) .
- Pull primary locking element -2-, release connector -1-, and pull it off ignition/starter switch - D- .

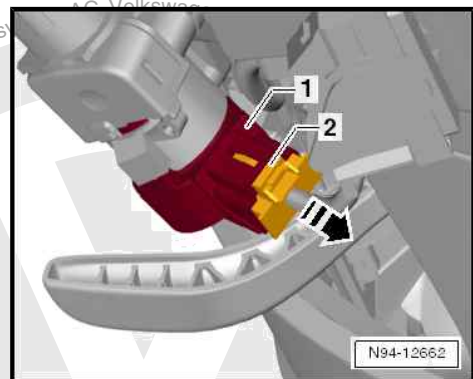

- Remove the locking paint of the two clamping screws -2-.
- Slightly loosen the two clamping bolts -2-, and pull ignition/starter switch - D- -1- in -direction of arrow- out of steering lock housing.

#### Installing

- Push ignition switch into steering lock housing.



#### Note

When installing the ignition/starter switch, ensure that the ignition/starter switch and the lock cylinder are in the same position, e.g. "ignition on".

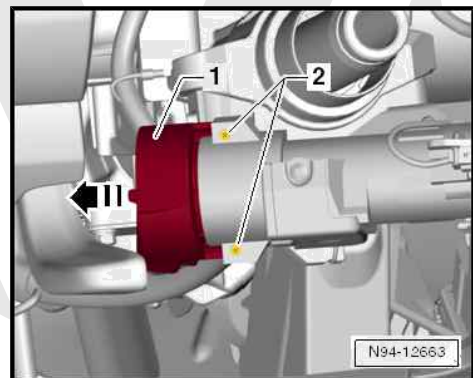

- Tighten clamping screws and seal with locking paint.
- Push connector onto ignition/starter switch, and push in primary locking element.
- Install all components in reverse order of removal.

### 7.1.5 Checking ignition/starter switch

- Connect vehicle diagnostic tester ⇒ [page 157](#) .



- Select operating mode "Guided Fault Finding" in vehicle diagnosis tester .
- Using "GoTo" button, select "Functions/component" and then the following menu options in succession:
  - ◆ Body
  - ◆ Electrical system
  - ◆ Self-diagnosis compatible systems
  - ◆ Onboard power supply control unit J519
  - ◆ Electrical components
  - ◆ Ignition/starter switch

### 7.1.6 Removing and installing lock cylinder

#### Removing

- Disconnect battery ⇒ [page 5](#) .
- Remove steering wheel ⇒ Running gear, axles, steering; Rep. gr. 48 ; Steering wheel; Assembly overview - steering wheel .
- Remove steering column trim ⇒ General body repairs, interior; Rep. gr. 68 ; Compartments/covers; Assembly overview - steering column trim .
- Release and pull connector -arrow- of immobiliser reader coil - D2- off the lock cylinder.

**i** Note

*The immobiliser reader coil - D2- is attached to the lock cylinder and cannot be renewed separately.*

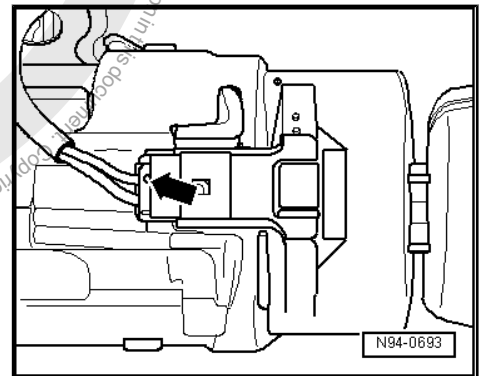

- Insert ignition key in lock cylinder and turn to "Drive" position.

Positions for key in lock cylinder:

- 1 - Position "Stop"
- 2 - Position "Drive"
- 3 - Position "Start"

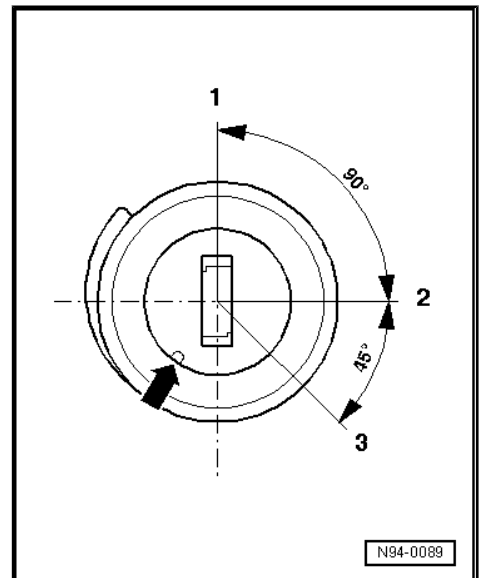



### Note

For reasons of clarity, the lock cylinder is shown in the following illustration without ignition key.

- Insert a piece of steel wire (approx. diameter: 1.2 mm) into hole -arrow- next to ignition key.
- Using steel wire -2- release locking lever -3- of lock cylinder -1- -arrow-.
- Pull lock cylinder -1- out of steering lock housing.

### Installing



### Note

For reasons of clarity, the ignition key is not shown in the following illustration.

- Insert ignition key in lock cylinder and turn to "Drive" position.
- Using steel wire -2- release locking lever -3- of lock cylinder -1- -arrow-.
- Insert lock cylinder -1- in steering lock housing.



### Note

The connection for the reader coil of the immobiliser must be inserted in the steering lock housing guide.

- Pull steel wire -2- out of lock cylinder -1- and check lock cylinder is seated correctly in the steering lock housing.
- Push connector -arrow- onto immobiliser reader coil - D2- on lock cylinder.
- Install all components in reverse order of removal.

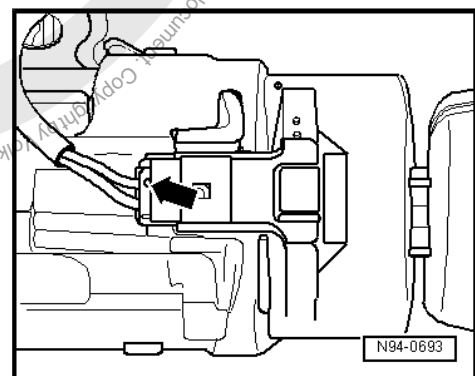
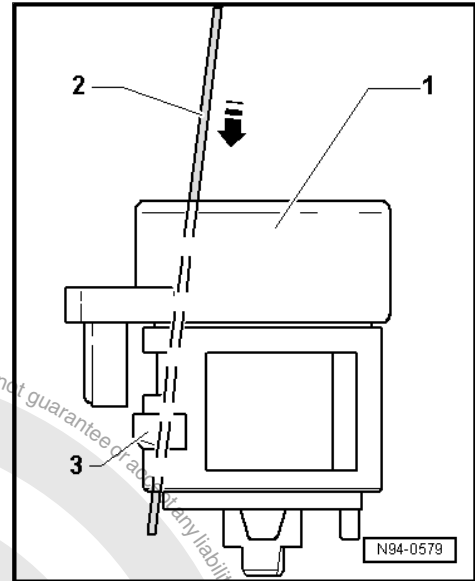

## 7.1.7 Removing and installing steering lock housing



### Caution

To disconnect and reconnect the battery, the procedure described in the workshop manual should be strictly adhered to ⇒ [page 5](#).



**Caution**

- ◆ *The steering lock could be destroyed.*
- ◆ *If the steering lock is actuated without lock cylinder, it will block and must be renewed.*
- ◆ *The steering lock must not be actuated without lock cylinder.*

**Special tools and workshop equipment required**

- ◆ Angle hand drill
- ◆ Torque wrench - V.A.G 1410

V.A.G 1410



W00-0554

**Removing**



**Note**

*To remove the steering lock housing, the shear bolts must be drilled out. New shear bolts are required for subsequent installation ⇒ ETKA (electronic parts catalogue) .*

- Disconnect battery ⇒ [page 5](#) .
- Remove dash panel insert ⇒ [page 36](#) .
- Remove steering column combination switch ⇒ [page 95](#) .
- Remove lock cylinder ⇒ [page 99](#) .
- Remove ignition/starter switch ⇒ [page 98](#) .



**Caution**

- ◆ *Ensure that all the components mounted on the steering lock housing have been removed before drilling out the shear-head bolts.*
- ◆ *The drilling operation can cause swarf to penetrate the adjacent components resulting in damage and/or malfunction!*



### WARNING

***Danger of eye injury from drilling swarf.***

***When drilling out, swarf may fly off and cause eye injury.***

***Wear safety goggles.***

- Undo screw -1- and remove cable.
- Drill out shear-head bolts -arrows- of steering lock housing -2-.



### Note

*M8 bolts -arrows-, core diameter 6.8 mm*

- Pull steering lock housing -2- towards the rear and off steering column.

### Installing

- Push steering lock housing -2- onto steering column in a straight line as far as it will go and align with the threaded holes.
- Secure steering lock housing -2- to steering column using new shear-head bolts -arrows-.
- Tighten new shear-head bolts -arrows- until bolt heads shear off.
- Secure cable with screw -1-.
- Install all components in reverse order of removal.

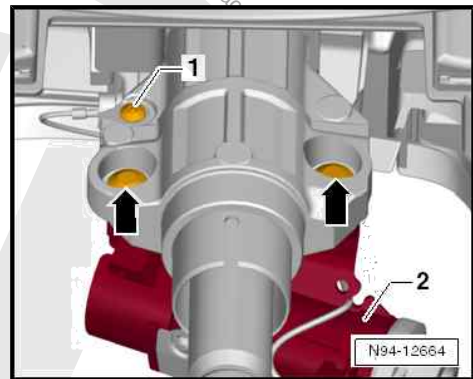
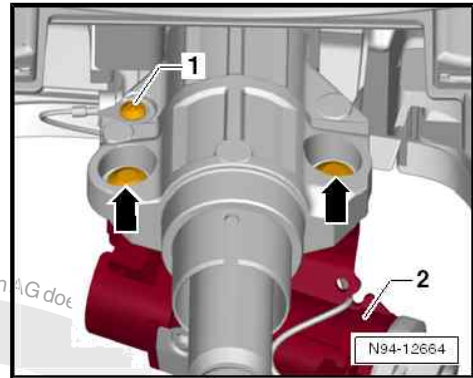



## 7.2 Steering column switch module 11.2013



⇒ [“7.2.1 Assembly overview - steering column switch module”, page 103](#)

⇒ [“7.2.2 Removing and installing airbag coil connector and return ring with slip ring F138”, page 104](#)

⇒ [“7.2.3 Removing and installing steering column combination switch E595”, page 106](#)

⇒ [“7.2.4 Removing and installing turn signal switch E2”, page 108](#)

⇒ [“7.2.5 Removing and installing cruise control system switch E45”, page 108](#)

⇒ [“7.2.6 Removing and installing intermittent wiper switch E22”, page 109](#)

⇒ [“7.2.7 Removing and installing ignition/starter switch D”, page 110](#)

⇒ [“7.2.8 Removing and installing lock cylinder”, page 110](#)

⇒ [“7.2.9 Removing and installing steering lock housing”, page 112](#)

⇒ [“7.2.10 Removing and installing ignition key withdrawal lock solenoid N376”, page 114](#)

### 7.2.1 Assembly overview - steering column switch module

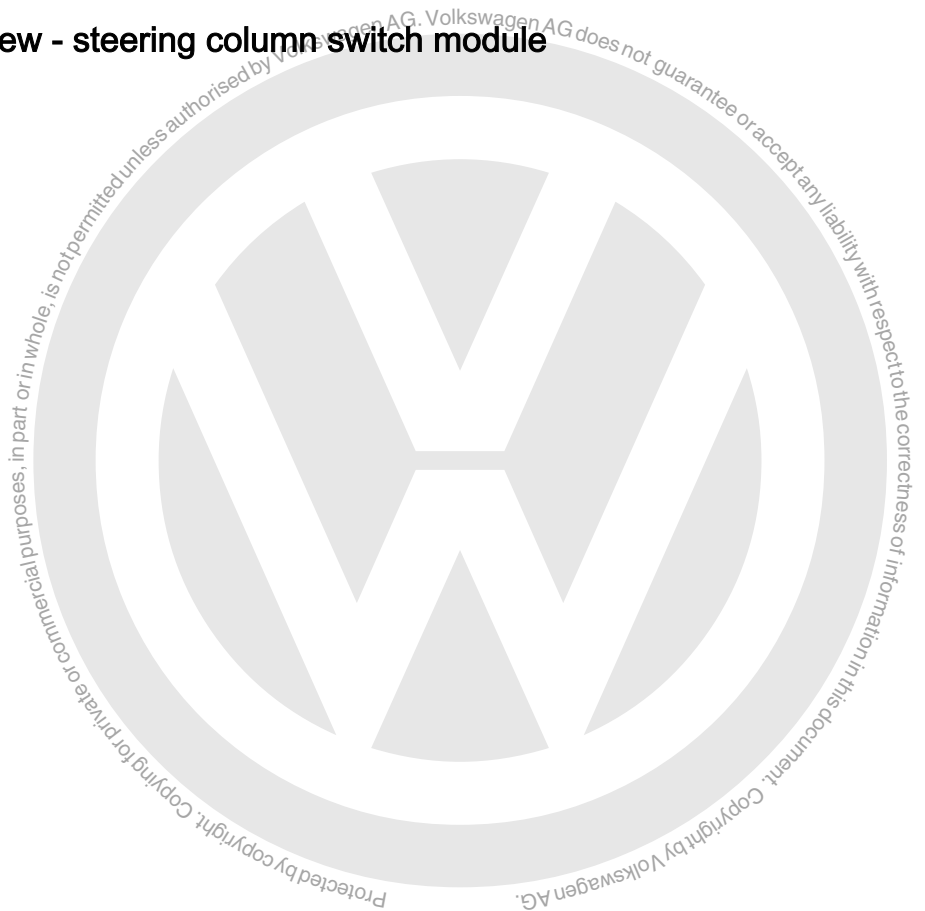



**1 - Shear bolt**

- For steering lock housing
- Qty. 2

**2 - Ignition key withdrawal lock solenoid - N376-**

- Only on vehicles with automatic gearbox or dual clutch gearbox
- Removing and installing ⇒ [page 114](#)

**3 - Ignition key**

**4 - Lock cylinder**

- Removing and installing ⇒ [page 110](#)
- With immobiliser reader coil - D2-
- Removing and installing immobiliser reader coil - D2- ⇒ [page 141](#)

**5 - Steering column combination switch - E595-**

- Removing and installing ⇒ [page 106](#)

**6 - Airbag coil connector and return ring with slip ring - F138-**

- Removing and installing ⇒ [page 104](#)

**7 - Bolt**

- Qty. 3
- 1.1 Nm

**8 - Ignition/starter switch - D-**

- Removing and installing ⇒ [page 110](#)

**9 - Steering lock housing**

- Removing and installing ⇒ [page 112](#)

**10 - Steering column**

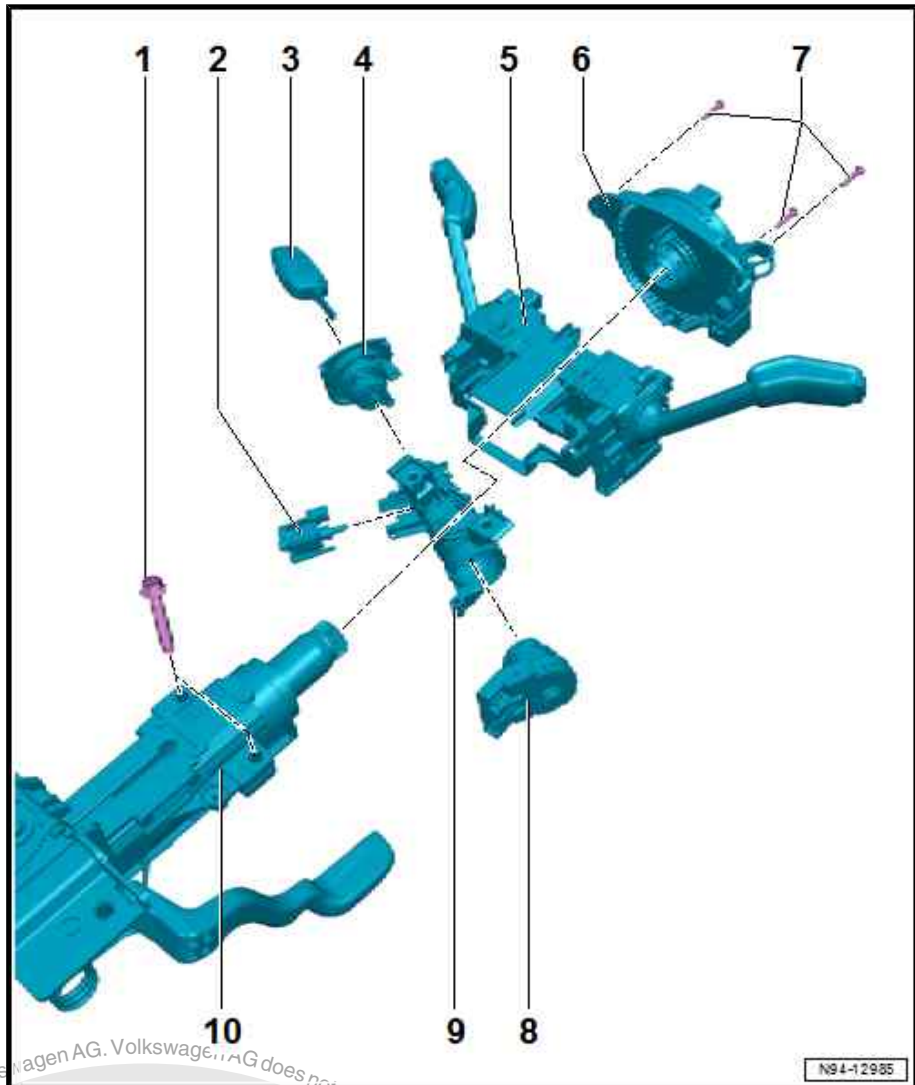

**7.2.2 Removing and installing airbag coil connector and return ring with slip ring - F138-**

**Special tools and workshop equipment required**





◆ Torque screwdriver - V.A.G 1624-

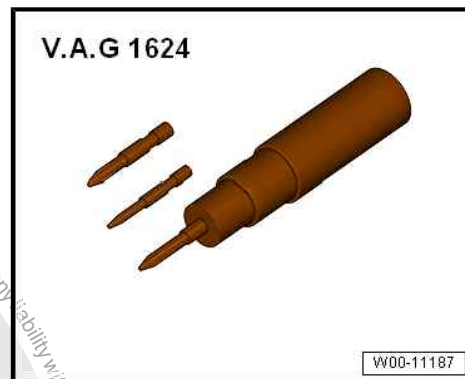

Depending on vehicle equipment, the steering angle sender - F138- may be integrated in the airbag coil connector and return ring with slip ring - G85- .



Note

*If the steering angle sender - G85- is defective, the airbag coil connector and return ring with slip ring - F138- must be renewed.*

Removing

- Remove lower steering column trim ⇒ General body repairs, interior; Rep. gr. 68 ; Compartments and covers; Removing and installing lower steering column trim .



WARNING

**Risk of damage to the electronic components due to electrostatic discharge.**

- ◆ *Before disconnecting the electrical connector, the mechanic must electrostatically discharge himself or herself by briefly grasping hold of door striker plate or similar.*



Caution

**Risk of damage to the return ring.**

- ◆ *The airbag coil connector and return ring with slip ring - F138- is not to be moved out of position.*



- Disconnect connector -2- on airbag coil connector and return ring with slip ring - F138- -1-.
- Unscrew bolts -arrows- of airbag coil connector and return ring with slip ring - F138- -1-.
- Remove airbag coil connector and return ring with slip ring - F138- -1- from steering column combination switch - E595- .

### Installing

Install in the reverse order of removal, observing the following:



#### Caution

**Risk of damage to airbag coil connector and return ring with slip ring - F138- .**

- ◆ **The airbag coil connector and return ring with slip ring - F138- is always centred when delivered as a replacement part.**
- ◆ **Do not change this setting.**

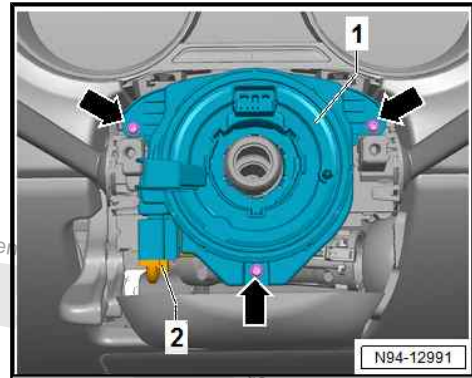

- Check the following before installing airbag coil connector and return ring with slip ring - F138- -1-:
- The airbag coil connector and return ring -2- must be visible through the aperture.

### Specified torques

- ◆ ⇒ [“7.2.1 Assembly overview - steering column switch module”, page 103](#)

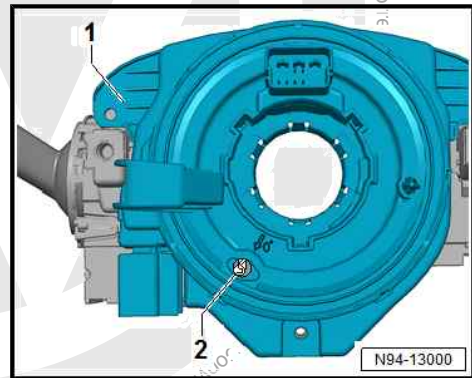

## 7.2.3 Removing and installing steering column combination switch - E595-

Depending on vehicle equipment, the following components are integrated into the steering column combination switch - E595- as one unit:

- ◆ Turn signal switch - E2-
- ◆ Headlight dipper and flasher switch - E4-
- ◆ Parking light switch - E19-
- ◆ Intermittent wiper switch - E22-
- ◆ Rear window wiper switch - E34-
- ◆ Intermittent wiper regulator - E38-
- ◆ Cruise control system switch - E45-
- ◆ Cruise control system (CCS) SET button - E227-



#### Note

*If one of the components is defective, the steering column combination switch - E595- must be renewed as a complete unit.*



## Removing

- Remove airbag coil connector and return ring with slip ring - F138- => [page 104](#) .
- Disconnect left connector -2- from steering column combination switch - E595- -1-.

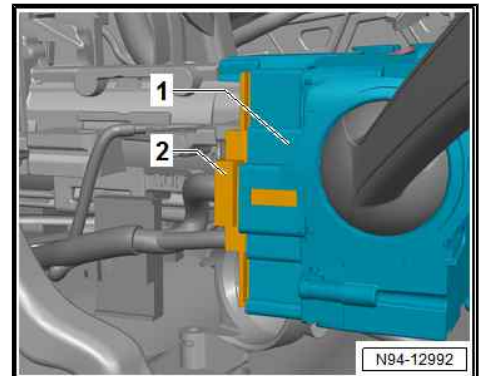

- Disconnect right connector -2- from steering column combination switch - E595- -1-.

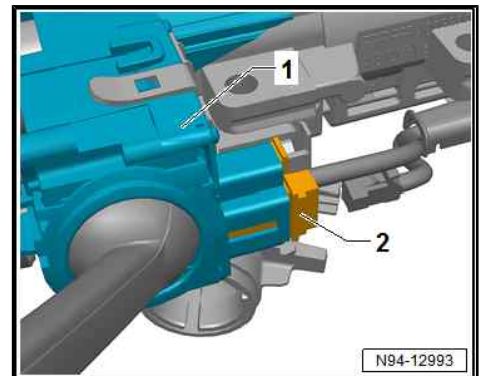

- Push upper retaining tabs -2- on steering column combination switch - E595- -1- in -direction of arrow-
- Pull steering column combination switch - E595- -1- at top slightly off steering column.

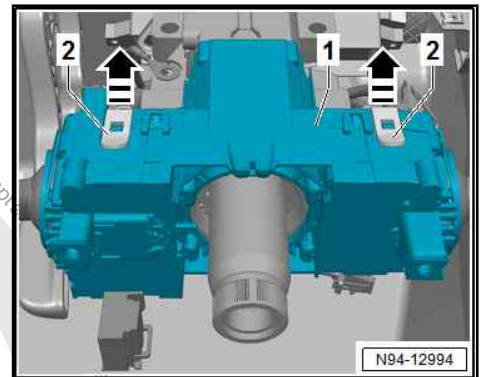

- Push lower retaining tabs -2- on steering column combination switch - E595- -1- in -direction of arrow-.
- Remove steering column combination switch - E595- -1- from steering column.

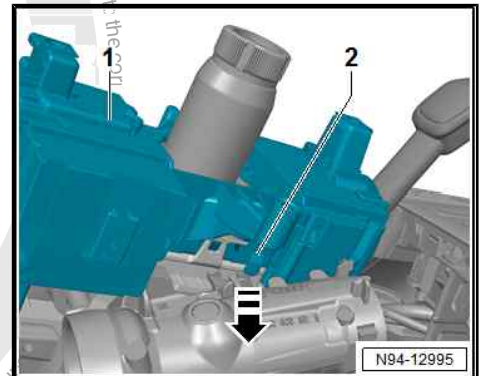

## Installing

Install in the reverse order of removal, observing the following:

- Install steering column combination switch - E595- , and engage it firmly at top and bottom.



## 7.2.4 Removing and installing turn signal switch - E2-

Depending on vehicle equipment, the following components are integrated into the steering column combination switch - E595- as one unit:

- ◆ Turn signal switch - E2-
- ◆ Headlight dipper and flasher switch - E4-
- ◆ Parking light switch - E19-
- ◆ Intermittent wiper switch - E22-
- ◆ Rear window wiper switch - E34-
- ◆ Intermittent wiper regulator - E38-
- ◆ Cruise control system switch - E45-
- ◆ Cruise control system (CCS) SET button - E227-



### Note

*If one of the components is defective, the steering column combination switch - E595- must be renewed as a complete unit.*

### Sequence of operations

- Removing and installing steering column combination switch - E595- → [page 106](#) .

## 7.2.5 Removing and installing cruise control system switch - E45-

Depending on vehicle equipment, the following components are integrated into the steering column combination switch - E595- as one unit:

- ◆ Turn signal switch - E2-
- ◆ Headlight dipper and flasher switch - E4-
- ◆ Parking light switch - E19-
- ◆ Intermittent wiper switch - E22-
- ◆ Rear window wiper switch - E34-
- ◆ Intermittent wiper regulator - E38-
- ◆ Cruise control system switch - E45-
- ◆ Cruise control system (CCS) SET button - E227-



### Note

*If one of the components is defective, the steering column combination switch - E595- must be renewed as a complete unit.*

### Sequence of operations

- Removing and installing steering column combination switch - E595- → [page 106](#) .



## 7.2.6 Removing and installing intermittent wiper switch - E22-

Depending on vehicle equipment, the following components are integrated into the steering column combination switch - E595- as one unit:

- ◆ Turn signal switch - E2-
- ◆ Headlight dipper and flasher switch - E4-
- ◆ Parking light switch - E19-
- ◆ Intermittent wiper switch - E22-
- ◆ Rear window wiper switch - E34-
- ◆ Intermittent wiper regulator - E38-
- ◆ Cruise control system switch - E45-
- ◆ Cruise control system (CCS) SET button - E227-



### Note

*If one of the components is defective, the steering column combination switch - E595- must be renewed as a complete unit.*

### Sequence of operations

- Removing and installing steering column combination switch - E595- => [page 106](#) .





## 7.2.7 Removing and installing ignition/starter switch - D-

### Removing

- Disconnect battery ⇒ [page 5](#) .
- Remove lower steering column trim ⇒ Rep. gr. 68 ; General body repairs, interior; Compartments/covers; Removing and installing lower steering column trim .
- Release electrical connector of ignition/starter switch - D- .
- Insert two small screwdrivers (e.g. jeweller screwdrivers) into openings -arrow- and lever off locking lugs to release ignition/starter switch - D- .
- Remove ignition/starter switch - D- -1- from steering lock.

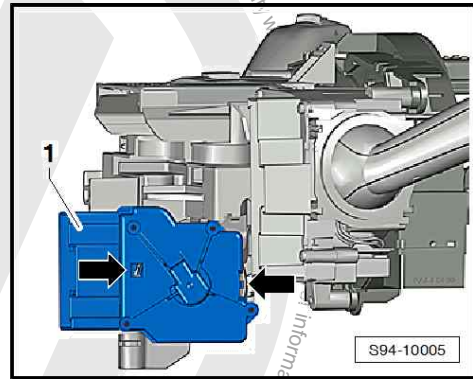

### Installing

Install in the reverse order of removal, observing the following:



#### Note

*When installing the ignition/starter switch, ensure that the ignition/starter switch and the lock cylinder are in the same position, e.g. "ignition on".*

- Insert ignition/starter switch - D- into steering lock until it can be heard to engage.

### Installing

Install in the reverse order of removal, observing the following:



#### Caution

**Risk of damage to the ignition/starter switch - D- .**

- ◆ *When delivered as a replacement part, the ignition/starter switch - D- is set to "On" position.*
- ◆ *Never set the ignition/starter switch - D- to another position than the "On" position.*

- Make sure that ignition/starter switch - D- is set to "On" position, and insert it in steering lock housing until it engages audibly.
- Connect battery ⇒ [page 5](#) .

## 7.2.8 Removing and installing lock cylinder

Special tools and workshop equipment required





- ◆ Locking pin - T40011- or suitable welding wire

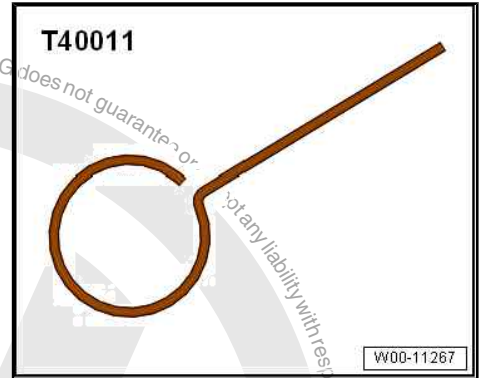

**i** Note

- ◆ *The immobiliser reader coil - D2- is integrated into the lock cylinder and cannot be renewed individually.*
- ◆ *If it is defective, the complete lock cylinder must be renewed.*

**Removing**

- Remove lower steering column trim ⇒ General body repairs, interior; Rep. gr. 68 ; Compartments and covers; Removing and installing lower steering column trim .

**⚠ WARNING**

**Risk of damage to the electronic components due to electrostatic discharge.**

- ◆ **Before disconnecting the electrical connector, the mechanic must electrostatically discharge himself or herself by briefly grasping hold of door striker plate or similar.**

- Disconnect connector -arrow- from immobiliser reader coil - D2- .

**i** Note

- ◆ *To remove the lock cylinder, it might be necessary to fold aside the ignition key.*
- ◆ *For reasons of clarity, the ignition lock is illustrated in the correct position without the ignition key.*

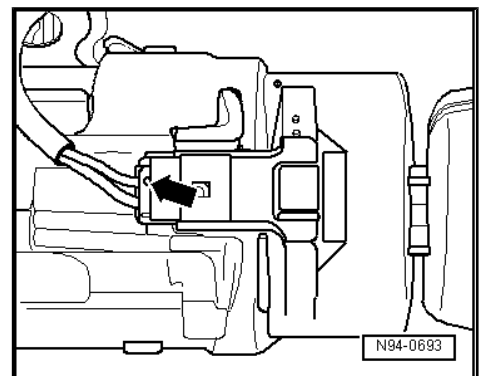

- Turn ignition key to "Ignition ON" position. This will align the recess in trim -arrow- with hole in ignition lock.

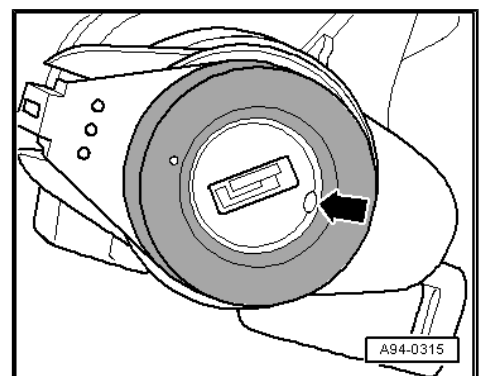





- Fold aside ignition key as far as possible.
- Insert locking pin - T40011- or suitable welding wire as far as stop in hole -2-, and release lock cylinder -1-.
- Pull lock cylinder -1- together with immobiliser reader coil - D2- out of steering lock housing.



#### WARNING

*Risk of seized steering lock.*

- ◆ *The steering lock must not be actuated without lock cylinder.*

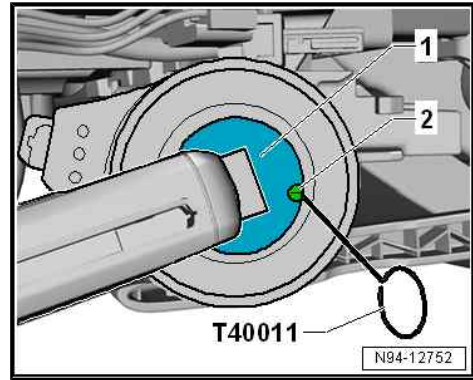

#### Note

*A seized steering lock must be renewed.*

#### Installing

Install in the reverse order of removal, observing the following:



#### Note

*A new lock cylinder can be ordered from the responsible distribution centre or the importer. When ordering, the vehicle-specific locking number according to the VIN must be provided.*

- Insert ignition key into lock cylinder and turn it to position "Ignition On".
- Insert locking pin - T40011- or suitable welding wire as far as stop into hole -2- again.
- Insert lock cylinder -1- together with immobiliser reader coil - D2- in steering lock housing -3-.
- Pull locking pin - T40011- or suitable welding wire out of hole -2-.
- Press in lock cylinder tightly until locking mechanism can be heard to engage.
- Connect connector to immobiliser reader coil - D2- .

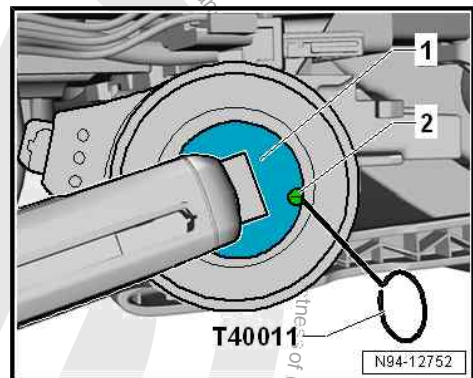

## 7.2.9 Removing and installing steering lock housing

#### Removing

- Remove steering column combination switch - E595-  
⇒ [page 106](#) .



**WARNING**

*Risk of damage to the electronic components due to electrostatic discharge.*

- ◆ *Before disconnecting the electrical connector, the mechanic must electrostatically discharge himself or herself by briefly grasping hold of door striker plate or similar.*

- Disconnect connector -2- on ignition/starter switch - D- -1-.

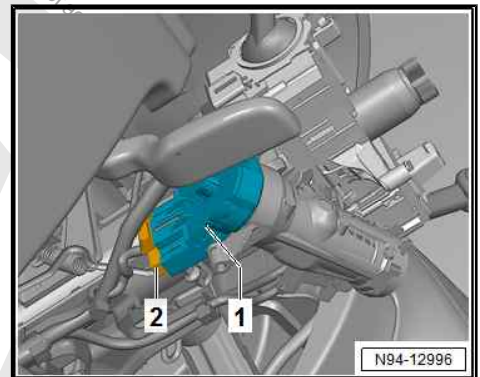

- Disconnect connector -arrow- from immobiliser reader coil - D2- .

**Vehicles with dual clutch gearbox**

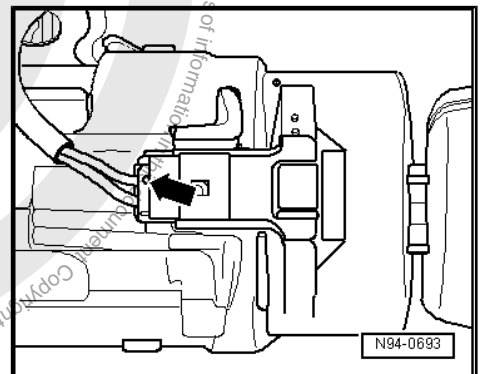

- Disconnect connector -2- from ignition key withdrawal lock solenoid - N376- -1-.

**Continued for all vehicles**



**WARNING**

*Danger of eye injury from drilling swarf.*

- ◆ *When drilling out, swarf may fly off and cause eye injury.*
- ◆ *Wear eye protection.*

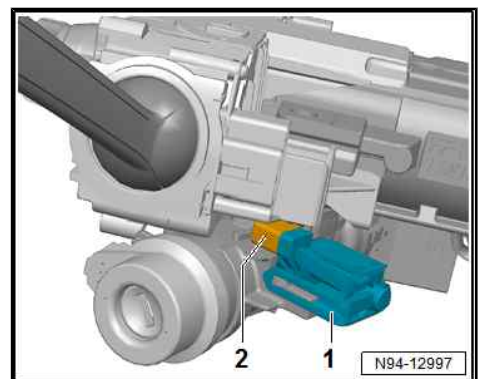

**Caution**

*Risk of damage to adjacent components.*

- ◆ *The drilling operation can cause swarf to penetrate the adjacent components resulting in damage and/or malfunction!*
- ◆ *Thoroughly remove any swarf.*



- Drill out shear heads -arrows- using an angle drill and an 8.5 mm drill bit.
- Remove steering lock housing from steering column.

The following components must be removed to renew the steering lock housing:

- ◆ Ignition/starter switch - D- ⇒ [page 110](#)
- ◆ Lock cylinder ⇒ [page 110](#)
- ◆ Ignition key withdrawal lock solenoid - N376- (vehicles with dual clutch gearbox) ⇒ [page 114](#)

### Installing

Install in the reverse order of removal, observing the following:

- Tighten new bolts -arrows- until shear heads break off.

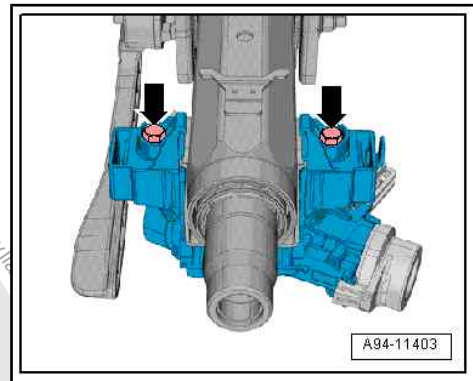
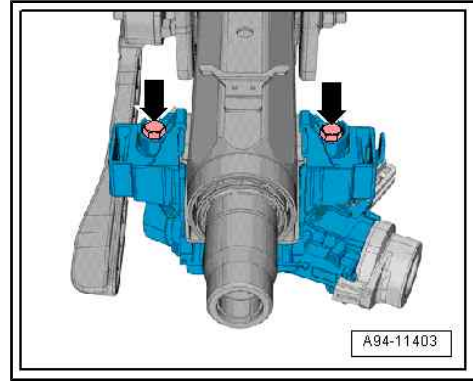

## 7.2.10 Removing and installing ignition key withdrawal lock solenoid - N376-

### Removing

Remove lower steering column trim ⇒ General body repairs, interior; Rep. gr. 68 ; Compartments and covers; Removing and installing lower steering column trim .



### WARNING

**Risk of damage to the electronic components due to electrostatic discharge.**

- ◆ **Before disconnecting the electrical connector, the mechanic must electrostatically discharge himself or herself by briefly grasping hold of door striker plate or similar.**

- Disconnect connector -2- from ignition key withdrawal lock solenoid - N376- -1-.
- Push retaining tab in -direction of arrow A-, and pull ignition key withdrawal lock solenoid - N376- -1- in -direction of arrow B- off steering lock housing -3-.

### Installing

Install in the reverse order of removal, observing the following:

- Perform functional check.

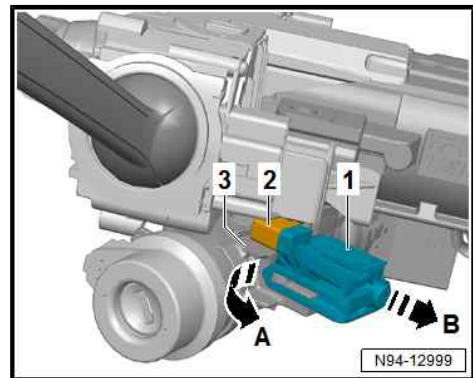



## 8 Parking aid

⇒ [“8.1 Assembly overview – parking aid”, page 115](#)

⇒ [“8.2 Removing and installing rear parking aid warning buzzer H15”, page 115](#)

⇒ [“8.3 Adapting volume and frequency of rear parking aid warning buzzer”, page 116](#)

⇒ [“8.4 Removing and installing rear parking aid senders”, page 116](#)

⇒ [“8.5 Removing and installing parking aid control unit J446”, page 118](#)

### 8.1 Assembly overview – parking aid

#### 1 - Parking aid senders in rear bumper cover

- Rear left parking aid sender - G203-
- Rear centre parking aid sender - G796-
- Rear right parking aid sender - G206-
- Removing and installing  
⇒ [page 116](#)

#### 2 - Parking aid control unit - J446-

- Removing and installing  
⇒ [page 118](#)
- Adapting functions of parking aid control unit  
⇒ [page 116](#)
- Coding parking aid control unit  
⇒ [page 116](#)

#### 3 - Parking aid warning buzzer - H15-

- Removing and installing  
⇒ [page 115](#)
- Adapting functions of warning buzzer  
⇒ [page 116](#)

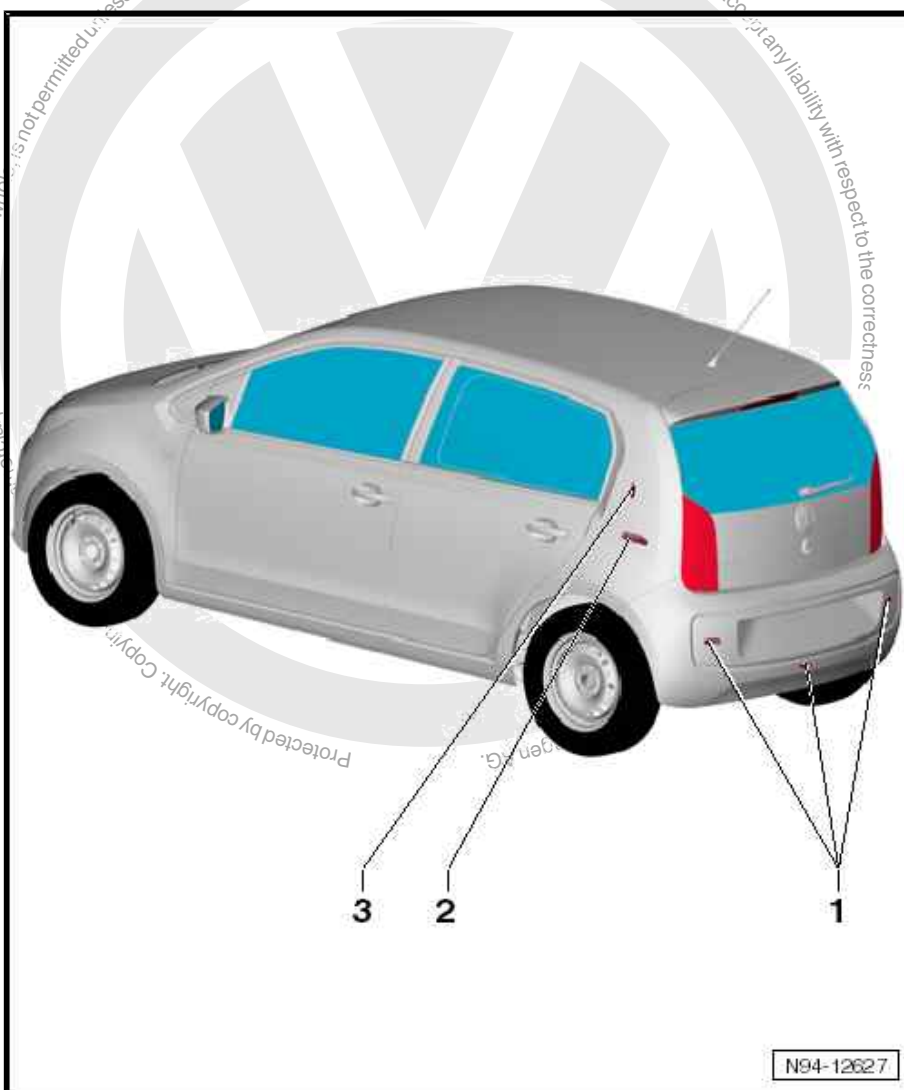

### 8.2 Removing and installing rear parking aid warning buzzer - H15-

The rear parking aid warning buzzer - H15- is under the right side panel trim in the luggage compartment.



## Removing

- Switch off ignition and all electrical consumers, and withdraw ignition key.
- Remove left luggage compartment side trim ⇒ General body repairs, interior; Rep. gr. 70 ; Luggage compartment trim; Assembly overview - luggage compartment side trim .
- Unscrew pins of spreader rivets, and release spreader rivets -arrows-.
- Release and pull off connector -2- and then remove warning buzzer -1-.

## Installing

Installation is carried out in the reverse sequence of removal.

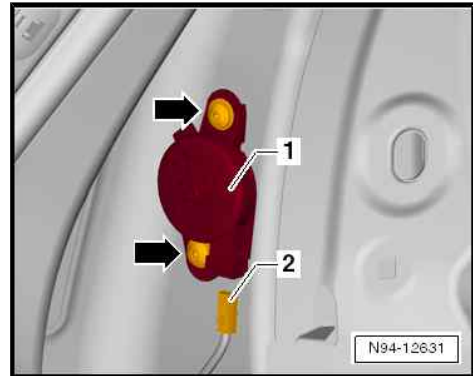

## 8.3 Adapting volume and frequency of rear parking aid warning buzzer

### Adapting parking aid control unit - J446-

The volume and frequency of the rear parking aid system warning buzzer - H15- can be adjusted by means of the parking aid control unit - J446- .

The following parking aid functions can be adapted with this programme:

- ◆ Activating tone for parking aid system
- ◆ Frequency of parking aid warning buzzer
- ◆ Volume of parking aid warning buzzer
- ◆ Lowering of the audio signal
- ◆ Optical display for assisted parking
- Connect vehicle diagnostic tester ⇒ [page 157](#) .
- Adapt volume and frequency of rear parking aid warning buzzer ⇒ Vehicle diagnostic tester.

### Coding parking aid control unit - J446-

- Connect vehicle diagnostic tester ⇒ [page 157](#) .
- Coding parking aid control unit - J446- ⇒ Vehicle diagnostic tester.

## 8.4 Removing and installing rear parking aid senders

The following parking aid senders are built into the rear bumper cover:

- ◆ Rear left parking aid sender - G203-
- ◆ Rear centre parking aid sender - G796-
- ◆ Rear right parking aid sender - G206-





**i Note**

- ◆ 3 parking aid senders are built into the rear bumper cover:
- ◆ To remove and install the two outer parking aid senders, the bumper cover must not be removed. The senders can be reached through the wheel housing.
- ◆ Removal and installation of the rear parking aid senders from and in the sender retainers is carried out in the same way for all senders and is described as follows for just one sender.

**Removing**

- Switch off ignition and all electrical consumers, and withdraw ignition key.



**Caution**

**The order for removing the senders must be adhered to under all circumstances.**

**The sender may otherwise be damaged. Fractures may occur if too much pressure is applied to the sender, and this may cause the sender to fail.**

**First, remove sender from holder and then release and pull off connector of sender.**

**Only for removing and installing the sender in the middle:**

- Remove rear bumper cover ⇒ General body repairs, exterior; Rep. gr. 63 ; Rear bumper; Assembly overview - rear bumper cover .

**Removal and installation of all senders, continued:**

- Unclip rubber cap -1- from sender retainer.

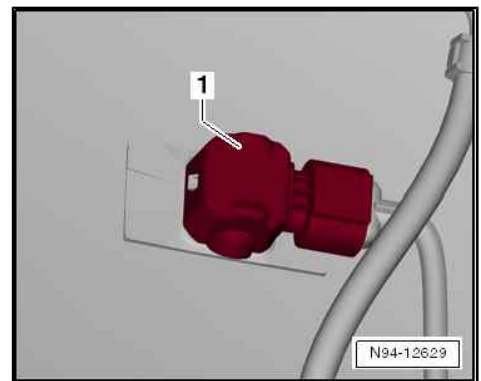

- Push fasteners -2- on sender retainer outwards.
- Pull sender -1- with wire connected towards rear and out of sender retainer.

**i Note**

- ◆ When removing the sender, make sure that the isolation ring (black silicone ring) on the sender head does not remain in the bracket or become lost.
- ◆ Stretching the isolation ring must be avoided under all circumstances.

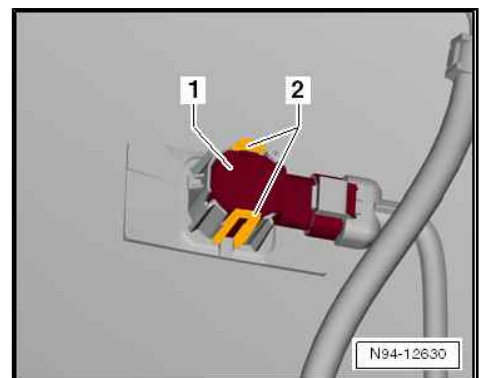



- Release connector -2- and then pull it off sender -1-.

### Installing

Install in the reverse order of removal observing the following:



#### Caution

*Function problems could occur if an incorrect or damaged isolation ring is used.*

*Stretching the isolation ring must be avoided under all circumstances.*

*Replace any damaged isolation rings and make sure that the right isolation ring is fitted in each case.*

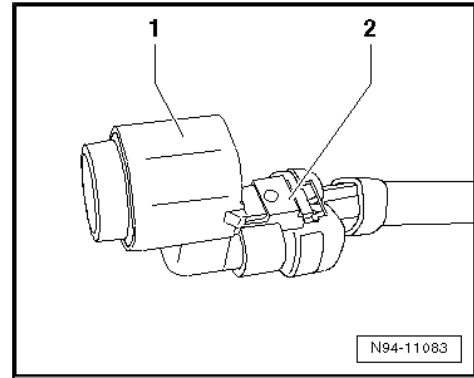

- Check isolation ring -1- of sender for damage and renew if necessary.



#### Note

- ◆ *When installing the sender, ensure that the isolation ring has been correctly fitted onto the sender head and does not ride or roll up on insertion into the sender retainer.*
- ◆ *Both locking lugs of sender retainer must audibly engage when installing the sender.*
- ◆ *Attach rubber cap to sender retainer so that it latches into place securely.*

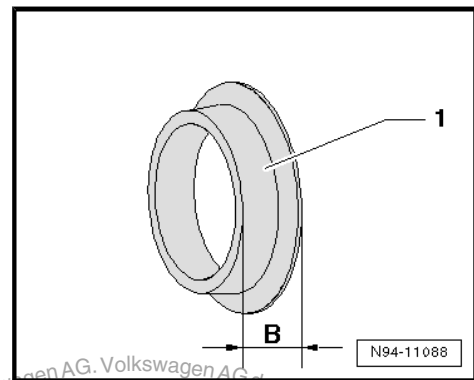

- After installing the sender, check that the sender is correctly seated in the bracket. The size -a- of the ring gap which is visible on the outer side of the bumper and is located between sender head and bumper cover must be the same all round.
- Check functions of parking aid system.

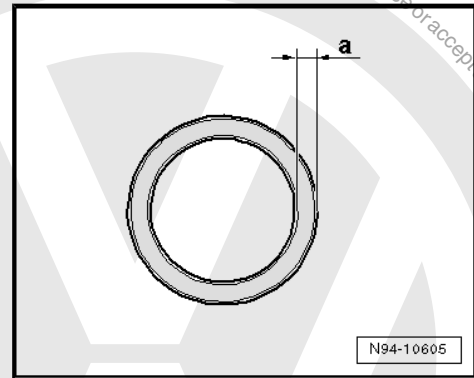

## 8.5 Removing and installing parking aid control unit - J446-

The parking aid control unit - J446- is located under the left side panel trim in the luggage compartment.

### Removing

- Switch off ignition and all electrical consumers, and withdraw ignition key.
- Remove left luggage compartment side trim ⇒ General body repairs, interior; Rep. gr. 70 ; Luggage compartment trim; Assembly overview - luggage compartment side trim .





- Release and pull off connector -2-.
- Undo the two nuts -arrows- and remove parking aid control unit - J446- -1-.

### Installing

Install in the reverse order of removal observing the following:

- Tighten the two nuts to torque specified in assembly overview  
⇒ [page 115](#) .

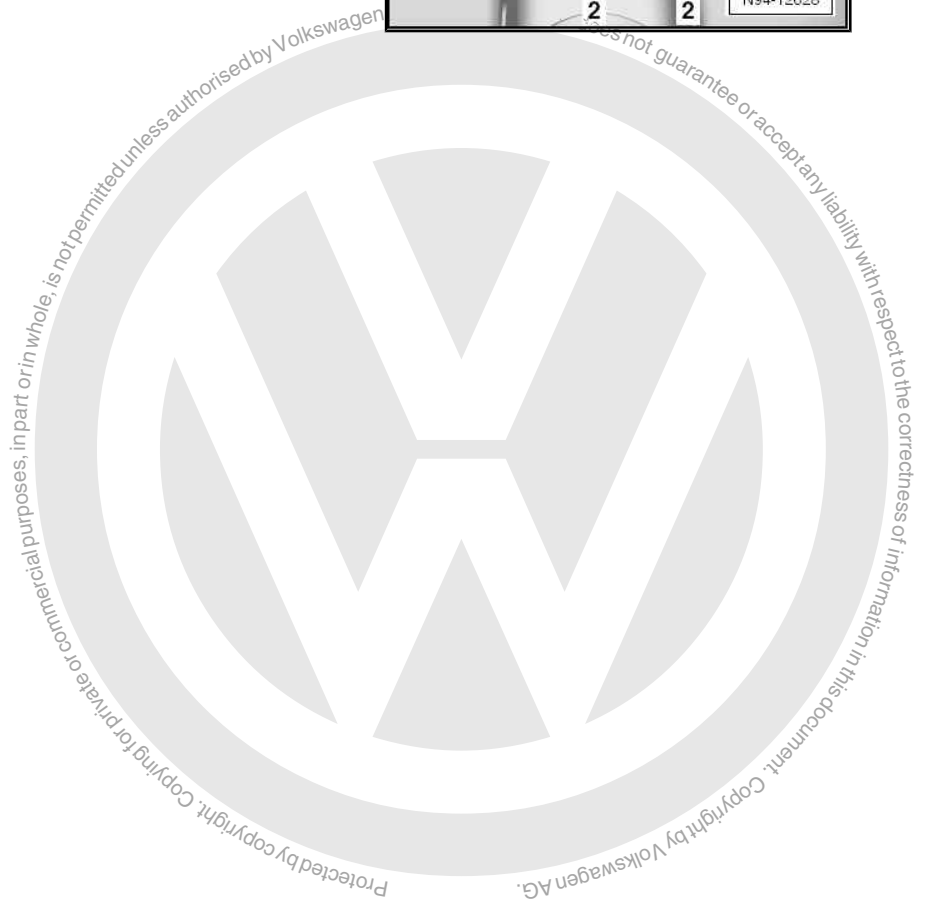
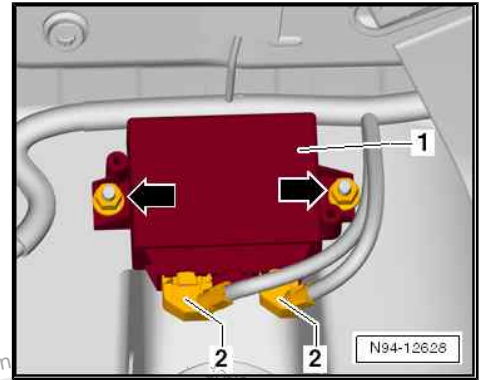



## 9 Emergency braking function

⇒ **“9.1 Removing and installing City Emergency Braking System”,  
page 120**

### 9.1 Removing and installing City Emergency Braking System

General description ⇒ [page 120](#)

Removing ⇒ [page 121](#)

Installing ⇒ [page 121](#)

#### General description

The emergency braking function detects the traffic situation by means of the emergency braking function sensor unit - J939- attached to the interior mirror up to a distance of around 10 metres in front of the vehicle in a speed range of approximately 5 km/h to 30 km/h.

If the system detects a possible collision with a vehicle driving in front, the vehicle is prepared for possible emergency braking. If the driver does not react to the threat of a collision, the system can brake the vehicle automatically in order to reduce the speed for a possible collision. If the emergency braking function determines that the driver does not brake sufficiently when faced with the threat of a collision, the system can increase the braking force in order to reduce the speed for a possible collision.

**In the following situations, it is possible that the emergency braking function will not react:**

- ◆ In tight curves
- ◆ When accelerator pedal is fully depressed
- ◆ If emergency braking function has been switched off or is faulty
- ◆ If the laser sensor is dirty, is covered or has overheated
- ◆ During a snowfall, in heavy rain or in dense fog
- ◆ If vehicle is offset in relation to other vehicles
- ◆ When other vehicles cut across the driving direction
- ◆ When there are oncoming vehicles in the same lane
- ◆ If vehicles are dirty with a low degree of reflection
- ◆ When there is a lot of dust in the air



#### Note

- ◆ *When the emergency braking function triggers a braking process, the pedal travel of the brake pedal decreases. As a result, the brake pedal feels “harder”.*
- ◆ *During automatic braking carried out by the emergency braking function, it is possible that unusual noises will occur. These are normal and are caused by the brake system.*
- ◆ *Automatic braking triggered by the emergency braking function can be cancelled by depressing the clutch pedal or the accelerator pedal, or by turning the steering wheel.*

The sensor unit for the emergency braking function - J939- is located under a cover next to the interior mirror.



## Removing

- Switch off ignition and all electrical consumers, and withdraw ignition key.
- Remove cover from interior mirror ⇒ General body repairs, interior; Rep. gr. 68 ; Interior mirror; Assembly overview - interior mirror .
- Release and pull off connector -1-.
- Pull catch -arrow- and remove sensor unit for emergency braking function - J939- -2- from holder on windscreen.

## Installing

Install in the reverse order of removal observing the following:



### Note

*Before installing, make sure that the sensor unit lenses and the windscreen in the installation area are clean in order to avoid malfunctions.*

- When installing the sensor unit -2-, first push it into the mounting -3- and then lock it securely into place with the catch -arrow-.



### Note

*If the sensor unit for the emergency braking function - J939- is removed, installed or replaced, coding or adaptation is not necessary.*

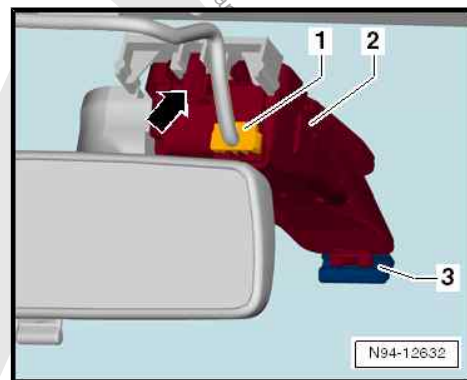
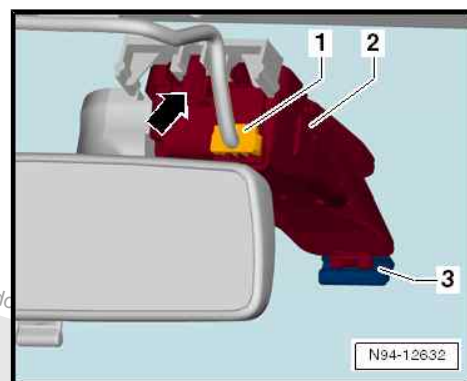



## 96 – Lights, bulbs, switches - interior

### 1 Lights

⇒ [“1.1 Removing and installing front passenger airbag warning lamp”, page 122](#)

⇒ [“1.2 Removing and installing indicator lamp for central locking SAFELOCK function”, page 122](#)

⇒ [“1.3 Checking indicator lamp for central locking SAFELOCK function”, page 122](#)

⇒ [“1.4 Removing and installing front interior and reading light”, page 123](#)

⇒ [“1.5 Removing and installing bulbs for front interior and reading light”, page 126](#)

⇒ [“1.6 Removing and installing front reading lights”, page 128](#)

#### 1.1 Removing and installing front passenger airbag warning lamp

The front passenger side airbag deactivated warning lamp - K145- is an integral part of the centre switch module in dash panel and cannot be renewed separately.

Removing and installing switch module in middle of dash panel  
⇒ [page 131](#) .

#### 1.2 Removing and installing indicator lamp for central locking SAFELOCK function

##### Removing

- Switch off ignition and all electrical consumers, and withdraw ignition key.
- Remove cover of door trim in mirror triangle ⇒ General body repairs, interior; Rep. gr. 70 ; Door trims; Assembly overview - front door trim .
- Press locking lugs -arrows- together, and pull central locking deadlock function warning lamp -SAFE- - K133- -1- out of cover of door trim.

##### Installing

Installation is carried out in the reverse sequence of removal.

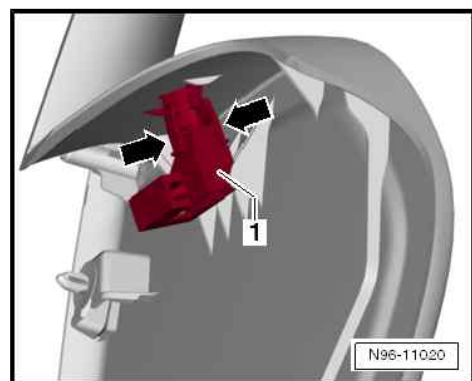

#### 1.3 Checking indicator lamp for central locking SAFELOCK function

The indicator lamp for the central locking SAFELOCK function - K133- can be checked by means of the final control diagnosis function of the onboard power supply control unit - J519- .



## 1.4 Removing and installing front interior and reading light

⇒ ["1.4.1 Removing and installing front interior light and reading light in vehicles without panoramic sunroof", page 123](#)

⇒ ["1.4.2 Removing and installing front interior and reading light in vehicles with panoramic sunroof", page 125](#)

### 1.4.1 Removing and installing front interior light and reading light in vehicles without panoramic sunroof

#### Special tools and workshop equipment required

- ◆ Torque wrench - V.A.G 1331-

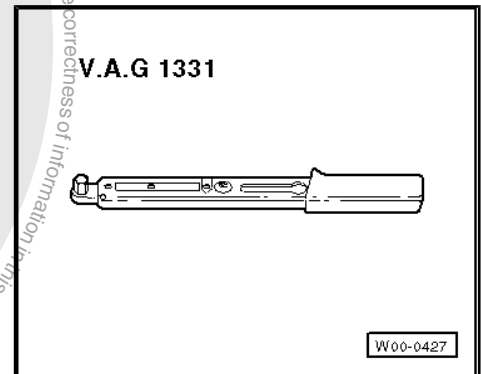

- ◆ Removal wedge - VAS 3409-

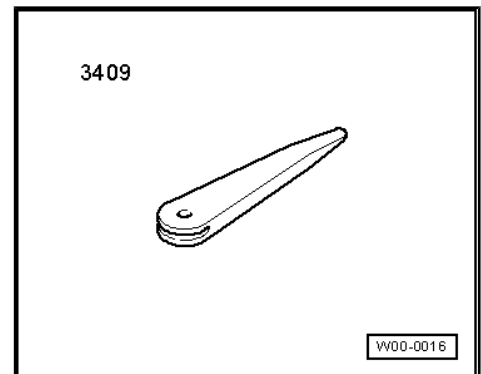

#### Note

*When removing and installing components that are in view (switches, covers, trim and so on), mask off areas in which tools (removal wedge - VAS 3409-, screwdriver) are used to lever out those components using commercially available masking tape.*

#### Removing

- Switch off ignition and all electrical consumers, and pull out ignition key.



- Using the removal wedge - VAS 3409- or a suitable screwdriver, carefully lever out the lens -1- at its catches -arrows- and remove it from the front interior light W1-2-

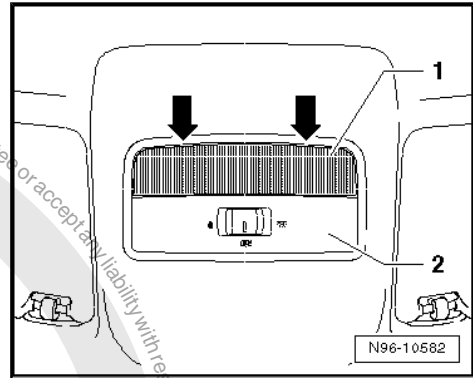

- Remove securing bolts -1-.
- Release the locking lugs by pushing them in -direction of arrows- and remove front interior light - W1- -2- from roof trim, taking connected wiring lengths into consideration.

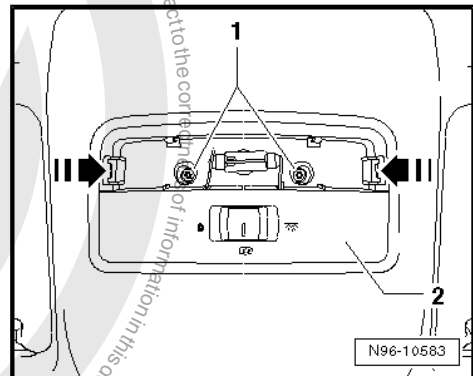

- Release and pull off connector -1-.

### Installing

Install in the reverse order of removal, observing the following:

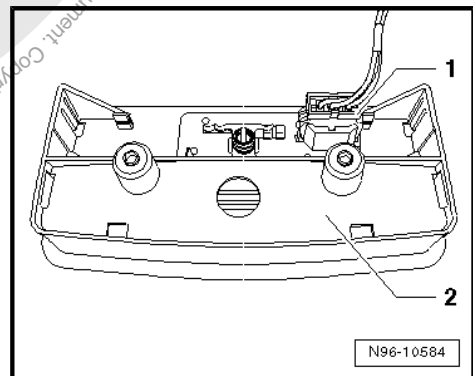

- Screw in securing bolts -1-.

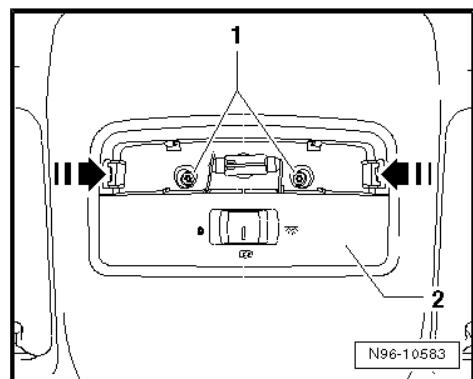

### Specified torques

Component	Specified torque
Securing bolts	1.5 Nm



## 1.4.2 Removing and installing front interior and reading light in vehicles with panoramic sunroof

The front interior and reading light contains the following components:

- ◆ Front interior light - W1-
- ◆ Front passenger reading light - W13-
- ◆ Driver side reading light - W19-
- ◆ Sliding sunroof adjustment regulator - EX4- ⇒ [page 139](#)

### Special tools and workshop equipment required

- ◆ Removal wedge - VAS 3409-

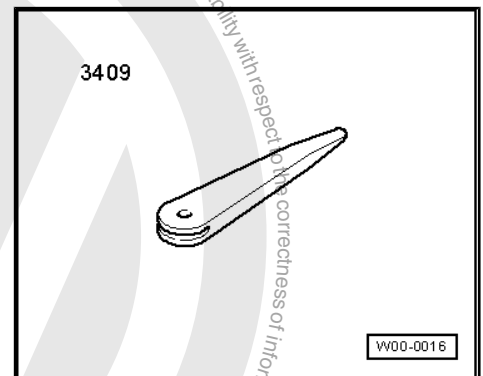

### Note

*When removing and installing components that are in view (switches, covers, trim and so on), mask off areas in which tools (removal wedge - VAS 3409-, screwdriver) are used to lever out those components using commercially available masking tape.*

### Removing

- Switch off ignition and all electrical consumers, and pull out ignition key.
- Using removal wedge - VAS 3409- , carefully lever off front interior and reading light lens -1- at catches -arrows-.

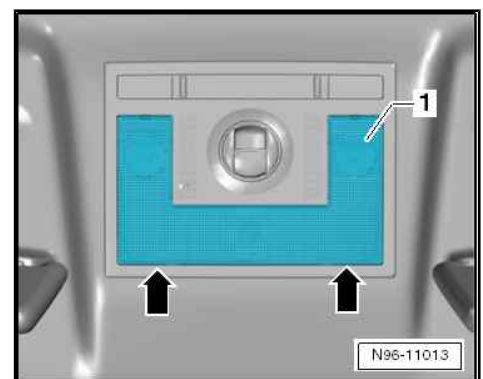





- Release the locking lugs by pushing them in -direction of arrows- and remove front interior and reading light -1- from roof trim, taking connected wiring lengths into consideration.

Release and detach connectors -1- and -2- and then remove front interior and reading light.

### Installing

Installation is carried out in reverse order of removal.

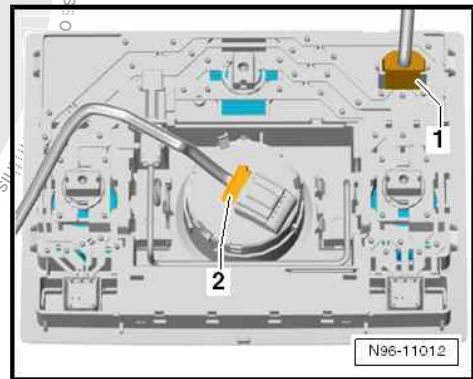
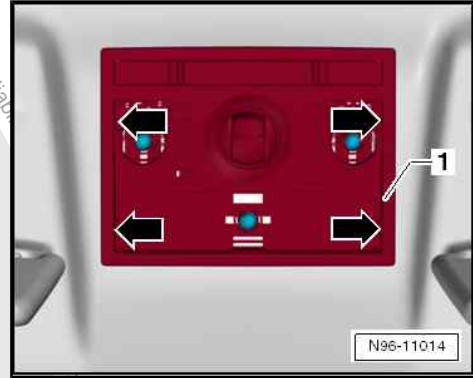

## 1.5 Removing and installing bulbs for front interior and reading light

⇒ [“1.5.1 Removing and installing bulbs for front interior and reading light in vehicles without panoramic sunroof”, page 126](#)

⇒ [“1.5.2 Removing and installing bulbs for front interior and reading light in vehicles with panoramic sunroof”, page 127](#)

### 1.5.1 Removing and installing bulbs for front interior and reading light in vehicles without panoramic sunroof



#### Note

*Bulb replacement does not involve removing front interior light - W1- .*

#### Removing

- Switch off ignition and all electrical consumers, and pull out ignition key.
- Remove lens ⇒ [page 123](#) .



- Remove bulb -2- from holder -1-.

Bulb for front interior light - W1- : festoon bulb 12V, 10W

### Installing

Installation is carried out in reverse order of removal.

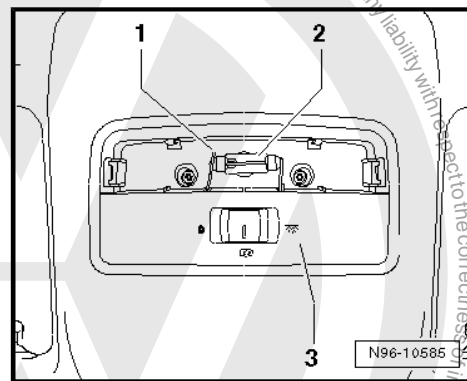

## 1.5.2 Removing and installing bulbs for front interior and reading light in vehicles with panoramic sunroof

### Special tools and workshop equipment required

- ◆ Removal wedge - VAS 3409-

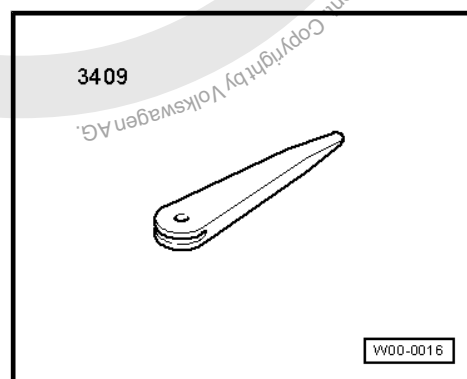

### Note

- ◆ *When removing and installing components that are in view (switches, covers, trim and so on), mask off areas in which tools (removal wedge - VAS 3409-, screwdriver) are used to lever out those components using commercially available masking tape.*
- ◆ *The front interior light - W1- has to be removed in order to change its bulb.*

### Removing

- Switch off ignition and all electrical consumers, and pull out ignition key.
- Remove front interior and reading light ⇒ [page 123](#) .



- Turn bulb holder -2- together with bulb of front interior light - W1- in -direction of arrow- and then remove.

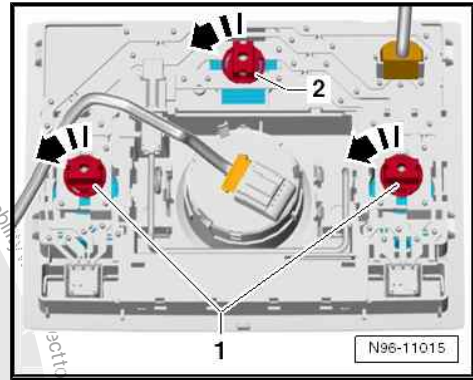

- Pull bulb -1- in -direction of arrow- out of bulb holder -2-.
- Bulb for front interior light - W1- : glass base bulb 12V, 5W.

### Installing

Installation is carried out in reverse order of removal.

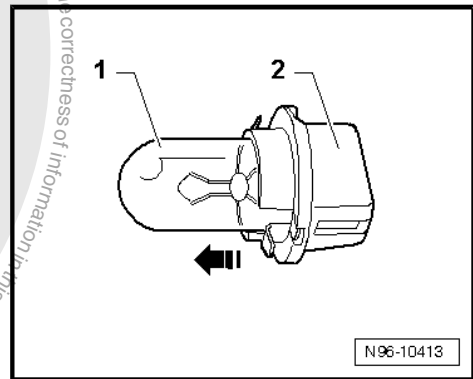

## 1.6 Removing and installing front reading lights

### Special tools and workshop equipment required

- ◆ Removal wedge - VAS 3409-

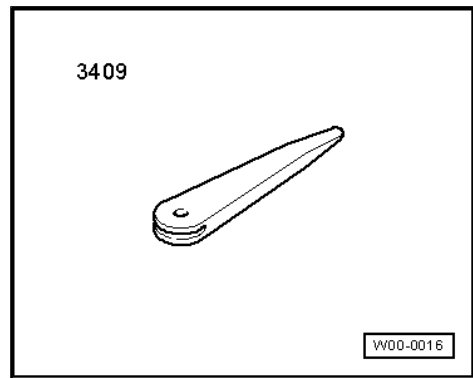

### Note

When removing and installing components that are in view (switches, covers, trim and so on), mask off areas in which tools (removal wedge - VAS 3409- , screwdriver) are used to lever out those components using commercially available masking tape.

### Removing

- Switch off ignition and all electrical consumers, and pull out ignition key.
- Remove front interior and reading light => [page 123](#) .



- Turn bulb holder -1- together with bulb of reading light in -direction of arrow- and then remove.

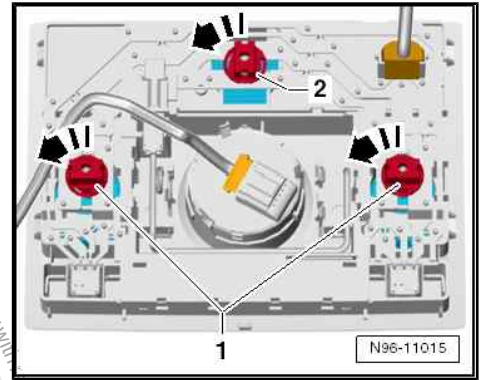

- Pull bulb -1- in -direction of arrow- out of bulb holder -2-.
- Renewing bulb for front passenger reading light - W13- or driver side reading light - W19- : glass base bulb 12V, 5W

**Installing**

Installation is carried out in reverse order of removal.

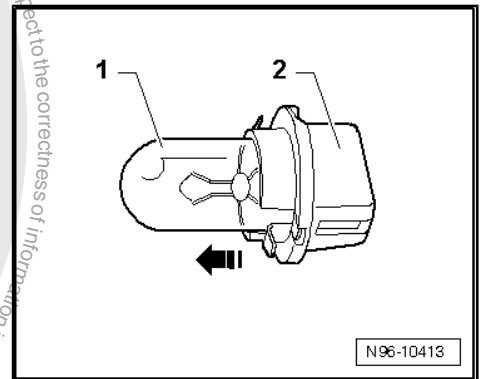



## 2 Controls

- ⇒ [“2.1 Removing and installing light switch”, page 130](#)
- ⇒ [“2.2 Removing and installing headlight range control regulator”, page 131](#)
- ⇒ [“2.3 Removing and installing switch module in middle of dash panel”, page 131](#)
- ⇒ [“2.4 Removing and installing start-stop operation button”, page 132](#)
- ⇒ [“2.5 Removing and installing hazard warning light switch”, page 133](#)
- ⇒ [“2.6 Removing and installing pushbutton for heated rear window”, page 133](#)
- ⇒ [“2.7 Removing and installing seat heater pushbutton”, page 133](#)
- ⇒ [“2.8 Removing and installing key-operated switch to deactivate front passenger side airbag”, page 133](#)
- ⇒ [“2.9 Removing and installing operating unit for window regulator in driver door E512”, page 134](#)
- ⇒ [“2.10 Removing and installing front window regulator switch”, page 135](#)
- ⇒ [“2.11 Removing and installing mirror adjustment switch E43 / E168”, page 136](#)
- ⇒ [“2.12 Removing and installing driver side interior locking button for central locking system”, page 137](#)
- ⇒ [“2.13 Removing and installing centre console switch module”, page 138](#)
- ⇒ [“2.14 Removing and installing pushbutton for emergency braking function”, page 139](#)
- ⇒ [“2.15 Removing and installing sliding sunroof adjustment regulator”, page 139](#)

### 2.1 Removing and installing light switch

The following components are integrated into the light switch - E1- depending on the equipment:

- ◆ Front and rear fog light switch - E23-
- ◆ Light switch illumination bulb - L9-

#### Removing

- Switch off ignition and all electrical consumers, and withdraw ignition key.
- Turn rotary knob of the light switch - E1- to the “0” position.
- Push grip of light switch - E1- in -1- and turn to right slightly -2-.
- Hold rotary knob in this position and pull light switch - E1- out of dash panel -3- by the rotary knob, taking connected wire lengths into consideration.
- Release and pull off connector.

#### Installing

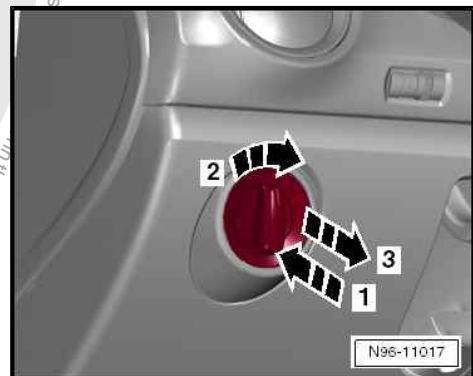



- Attach connector so that it latches into place.
- Hold light switch and press rotary knob of light switch - E1- firmly into dash panel -1- and then turn knob clockwise a little -2-.
- Hold rotary grip in this position and insert light switch - E1- into dash panel -3- using rotary grip.
- Turn grip of light switch to position "0", release and engage light switch -E1- .

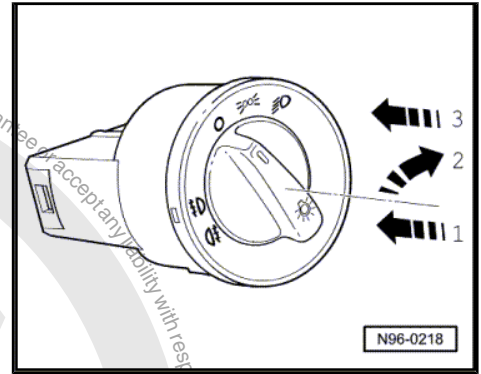

## 2.2 Removing and installing headlight range control regulator

### Removing

- Switch off ignition and all electrical consumers, and pull out ignition key.
- Remove footwell trim on driver side ⇒ General body repairs, interior; Rep. gr. 68 ; Storage compartments/covers; Assembly overview - dash panel cover on driver side .



*For reasons of clarity, the following illustration shows the installed headlight range control regulator - E102- from the rear.*

- Reach behind the dash panel and press together the two catches -arrows- on headlight range control regulator - E102- .
- Press headlight range control regulator - E102- -2- out of dash panel towards interior of vehicle.
- Release and pull off connector -1-.

### Installing

Installation is carried out in reverse order of removal.

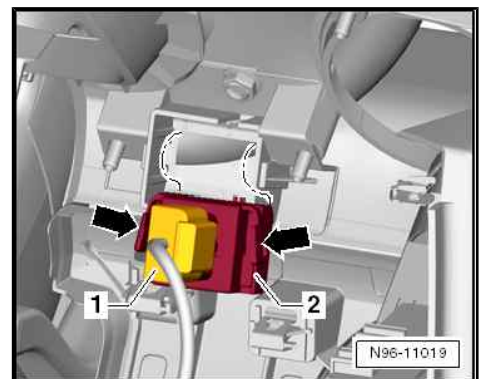

## 2.3 Removing and installing switch module in middle of dash panel

Depending on vehicle equipment, the following buttons and lights are integrated in the 2 switch modules on the left and right of the heating/air-conditioning controls. The procedure for removal and installation is identical for both switch modules and is therefore described for one switch module only. The removed switch modules cannot be dismantled further.

- ◆ Warning lamp button - E229-
- ◆ Front passenger side airbag deactivated warning lamp - K145-
- ◆ Heated rear window button - E230-
- ◆ Right seat heating button - E654-
- ◆ Left seat heating button - E653-
- ◆ Start/stop operation switch - E693-





### Special tools and workshop equipment required

- ◆ Removal wedge - VAS 3409-

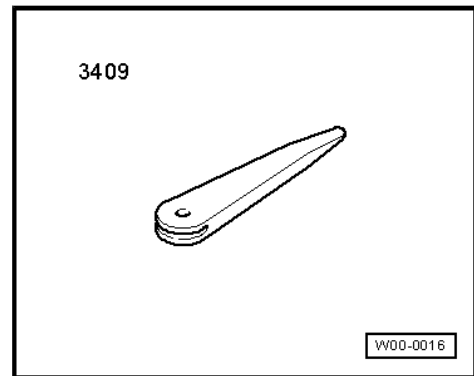

### Note

- ◆ *When removing and installing components that are in view (switches, covers, trim and so on), mask off areas in which tools (removal wedge - VAS 3409-, screwdriver) are used to lever out those components using commercially available masking tape.*
- ◆ *The procedure for removal and installation is identical for both switch modules and is therefore described for one switch module only.*

### Removing

- Switch off ignition and all electrical consumers, and withdraw ignition key.
- Remove dash panel trim in the middle ⇒ General body repairs, interior; Rep. gr. 68 ; Storage compartments/covers; Fitting locations overview - storage compartments/covers .
- Prise out the switch module in the middle of the dash panel, using the removal wedge - VAS 3409- to release the catches -arrows.
- Release and pull off connector and then remove switch module.

### Installing

Installation is carried out in reverse order of removal.

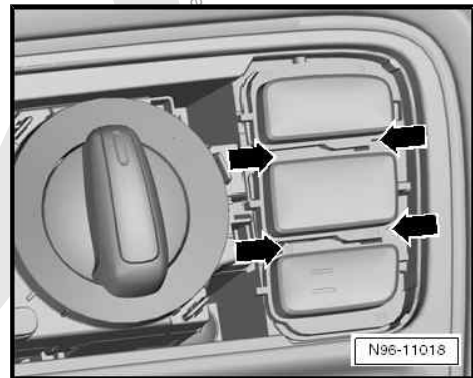

## 2.4 Removing and installing start-stop operation button

The pushbutton for start/stop mode - E693- is an integral part of the switch module in middle of dash panel and cannot be replaced separately.

- Removing and installing switch module in middle of dash panel ⇒ [page 131](#) .





## 2.5 Removing and installing hazard warning light switch

The hazard warning light switch - E229- is an integral part of the switch module in middle of dash panel and cannot be replaced separately.

Removing and installing switch module in middle of dash panel  
⇒ [page 131](#) .

## 2.6 Removing and installing pushbutton for heated rear window

The pushbutton for heated rear window - E230- is an integral part of the switch module in middle of dash panel and cannot be replaced separately.

Removing and installing switch module in middle of dash panel  
⇒ [page 131](#) .

## 2.7 Removing and installing seat heater pushbutton

The pushbutton for the seat heater on the right - E654- and the pushbutton for the seat heater on the left - E653- are integral parts of the switch module in middle of dash panel and cannot be replaced separately.

Removing and installing switch module in middle of dash panel  
⇒ [page 131](#) .

## 2.8 Removing and installing key-operated switch to deactivate front passenger side airbag

The key-operated switch for deactivating the front passenger side airbag - E224- is located in the cover on the side of the dash panel on the front passenger side.



### WARNING

- ◆ *Danger of the triggering of the airbag!*
- ◆ *Improper action on airbag unit may result in the triggering of the airbag!*
- ◆ *Observe safety precautions when working on airbag.*



### Note

*When removing and installing components that are in view (switches, covers, trim and so on), mask off areas in which tools (removal wedge - VAS 3409- , screwdriver) are used to lever out those components using commercially available masking tape.*

**Special tools and workshop equipment required**



◆ Removal wedge - VAS 3409-

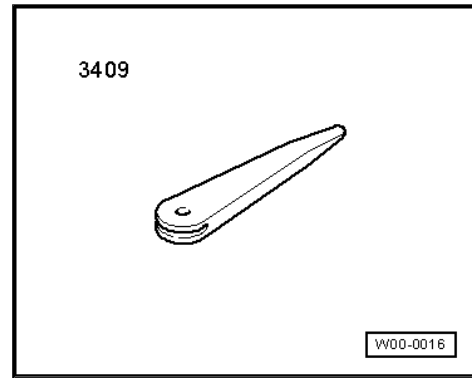

**Removing**

- Switch off ignition and all electrical consumers, and withdraw ignition key.
- Remove cover on side of dash panel on front passenger side ⇒ General body repairs, interior; Rep. gr. 68 ; Storage compartments/covers; Assembly overview - dash panel cover on driver side .
- Release and pull off connector -1-.
- Press catches -arrows- on both sides and push the key-operated switch for deactivating the front passenger side airbag -E224- -2- through the dash panel cover.

**Installing**

Installation is carried out in the reverse sequence of removal.

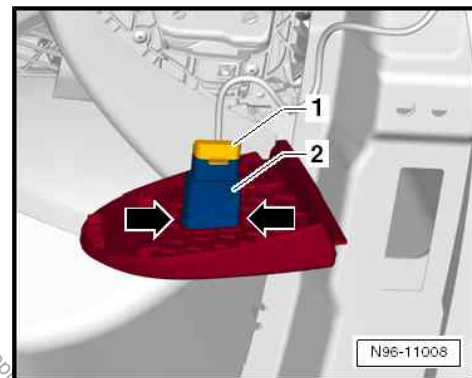

**2.9 Removing and installing operating unit for window regulator in driver door - E512-**

**Special tools and workshop equipment required**

◆ Removal wedge - VAS 3409-

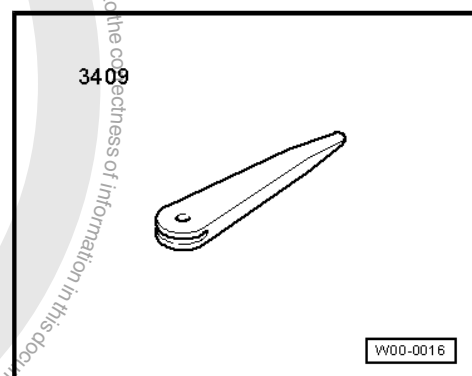

Depending on vehicle equipment, the operating unit for window regulator in driver door - E512- comprises the following buttons:

Driver side:

- ◆ Front left window regulator switch - E40-
- ◆ Driver side interior locking button for central locking system - E308-



- ◆ Mirror adjustment switch - E43-

Front passenger side:

- ◆ Front right window regulator switch - E41-



**Note**

- ◆ *The operating unit for window regulator in driver door - E308- must be removed before the driver side interior locking button for central locking system - E43- and the mirror adjustment switch - E512- can be removed or installed.*
- ◆ *The front left window regulator switch - E40- or the front right window regulator switch - E41- can be removed without the operating unit for window regulator in driver door - E512- having to be removed first.*
- ◆ *When removing and installing components that are in view (switches, covers, trim and so on), mask off areas in which tools (removal wedge - VAS 3409-, screwdriver) are used to lever out those components using commercially available masking tape.*

**Removing**

- Switch off ignition and all electrical consumers, and withdraw ignition key.
- Remove door panel trim on driver side ⇒ General body repairs, interior; Rep. gr. 70 ; Door trims; Assembly overview - front door trim .
- Release catches -arrows- of operating unit for window regulator in driver door - E512- -1- using the removal wedge - VAS 3409- or a suitable screwdriver.
- Remove switch element on driver side -1- from the door trim, beginning at the front.

**Installing**

Install in the reverse order of removal observing the following:

- Insert switch element on driver side -1- into the door trim, beginning at the rear -2-, and then push it in so that it latches into place securely.

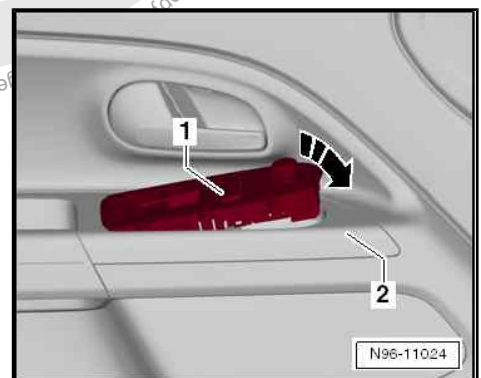
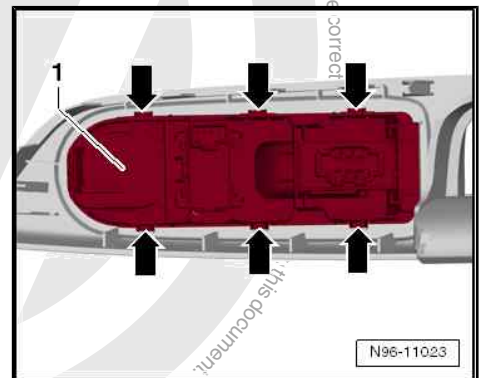

**2.10 Removing and installing front window regulator switch**

Special tools and workshop equipment required



◆ Removal wedge - VAS 3409-

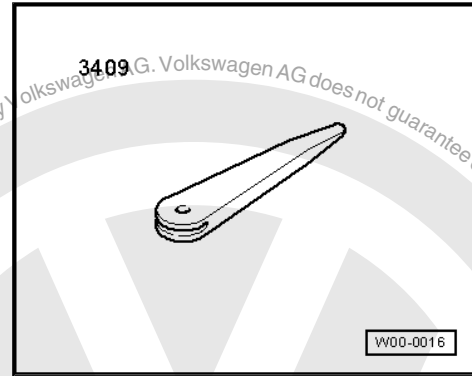

**Note**

- ◆ The following illustrations show removal and installation of the front left window regulator switch - E40- .
- ◆ Removal and installation of the front right window regulator switch - E41- are carried out in the same way.
- ◆ The operating unit for window regulator in driver door - E40- must not be removed in order to remove the front left window regulator switch - E512- .

**Removing**

- Switch off ignition and all electrical consumers, and withdraw ignition key.
- Remove front door trim ⇒ General body repairs, interior; Rep. gr. 70 ; Door trims; Assembly overview - front door trim .
- Release the two catches -arrows-, and remove front left window regulator switch - E40- -1- from operating unit for window regulator in driver door - E512- .

**Installing**

Installation is carried out in the reverse sequence of removal.

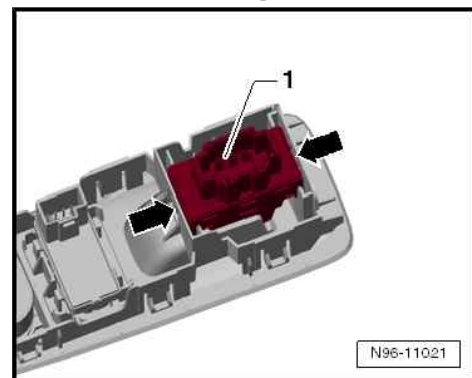

## 2.11 Removing and installing mirror adjustment switch -E43- / -E168-

Special tools and workshop equipment required



- ◆ Removal wedge - VAS 3409-

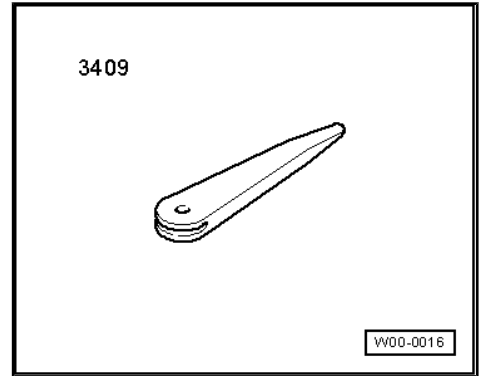

### Removing

- Remove switch element on driver side ⇒ [page 134](#) .
- Release the two catches -arrows-, and push mirror adjustment switch - E43- -1- out of operating unit for window regulator in driver door - E512- .

### Installing

Installation is carried out in the reverse sequence of removal.

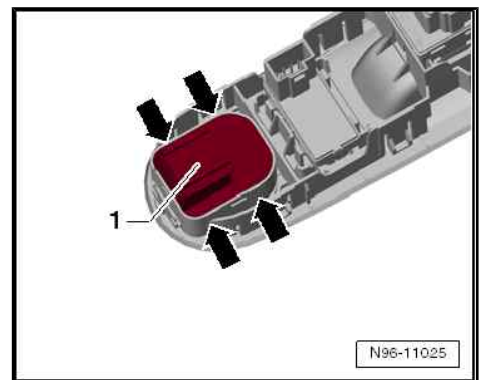

## 2.12 Removing and installing driver side interior locking button for central locking system

### Special tools and workshop equipment required

- ◆ Removal wedge - VAS 3409-

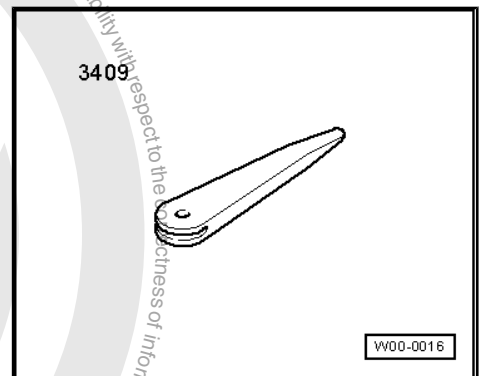

### Removing

- Remove operating unit for window regulator in driver door - E512- ⇒ [page 134](#) .



- Release the two catches -arrows-, and push driver side interior locking button for central locking system - E308- -1- out of operating unit for window regulator in driver door - E512- .

### Installing

Installation is carried out in the reverse sequence of removal.

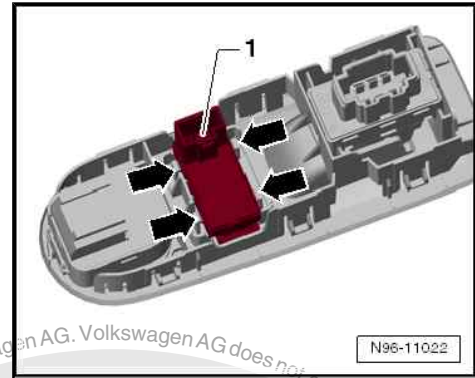

## 2.13 Removing and installing centre console switch module

The centre console switch module - EX23- is located in the centre console in front of the gear lever and, depending on the equipment in the vehicle, contains the following components:

- ◆ Tyre pressure monitor display button - E492-
- ◆ Pushbutton for emergency braking function - E773-
- ◆ Socket - U- or cigarette lighter - U1-

### Removing

- Switch off ignition and all electrical consumers, and withdraw ignition key.
- Remove cover of centre console ⇒ General body repairs, interior; Rep. gr. 68 ; Centre console; Assembly overview - centre console .
- Release the two catches -arrows- and pull the mounting frame -1- outwards out of centre console -2-.

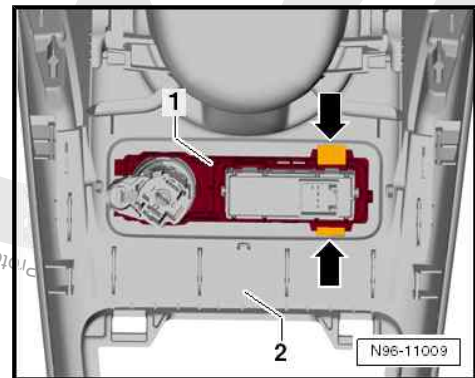

- Release the catches -arrows- with a suitable screwdriver and push centre console switch module - EX23- -1- out of mounting frame -2-.

### Installing

Install in the reverse order of removal observing the following:

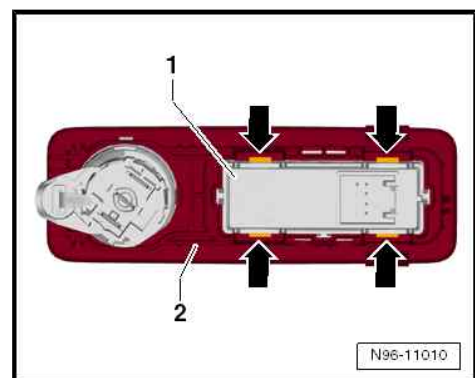





- First insert right side of mounting frame -1- into cover of centre console -2- and then push mounting frame in on left side to ensure it locks into place securely.

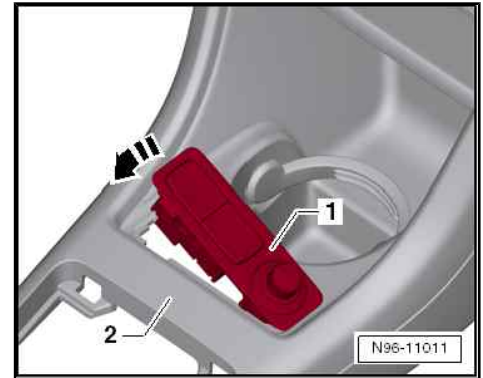

## 2.14 Removing and installing pushbutton for emergency braking function

The pushbutton for emergency braking function - E773- is an integral part of centre console switch module 1 - EX23- in the centre console in front of the gear lever.

Removing and installing centre console switch module - EX23-  
=> [page 138](#) .

## 2.15 Removing and installing sliding sunroof adjustment regulator

### Removing

- Switch off ignition and all electrical consumers, and pull out ignition key.
- Remove front interior and reading light => [page 123](#) .
- Release catches -arrows- and remove sliding sunroof adjustment regulator - EX4- -3- from interior and reading light.

### Installing

Installation is carried out in reverse order of removal.

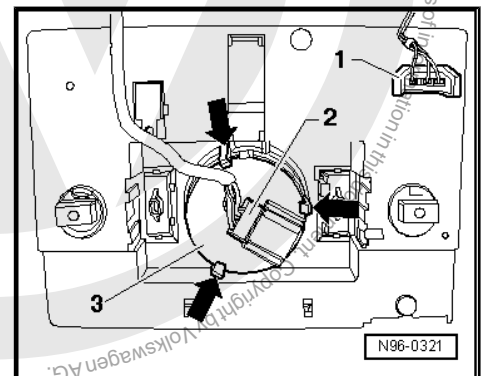





## 3 Immobiliser

⇒ [“3.1 Removing and installing immobiliser control unit”, page 140](#)

⇒ [“3.2 Removing and installing immobiliser reader coil”, page 141](#)

### 3.1 Removing and installing immobiliser control unit

#### General description:

The up! is equipped with a fourth-generation immobiliser with on-line link and download. The main component of the fourth generation immobiliser is a central database, in which all of the theft-relevant data from the participating control units is stored. Adapting the control units associated with the immobiliser is not possible without an online link to this database.

Online system test ⇒ [page 157](#) .

- ◆ A PIN request for the immobiliser components via fax or temporary access authorisation to the components is not available.
- ◆ All components associated with the immobiliser must be adapted online.
- ◆ All ignition keys (including re-ordered ones) are pre-coded to a specific vehicle in the factory and can only be adapted to this vehicle.
- ◆ The respective vehicle identification number must be specified when re-ordering ignition keys.
- ◆ It is no longer possible to adapt components of other brands for use in Volkswagen vehicles.

#### Immobiliser components:

- ◆ Immobiliser control unit - J362- ⇒ [page 140](#)
- ◆ Engine control unit - J623- ⇒ Rep. gr. 24 ; Engine control unit
- ◆ Immobiliser reader coil - D2- ⇒ [page 141](#)
- ◆ Ignition key



#### Note

*After lock set or control units have been replaced, the “New identity on renewing all components” function must be called up.*

#### Immobilizer control unit - J362- functions:

- ◆ Communication between all components associated with the immobiliser.
- ◆ Encryption of data between associated control units.

The immobiliser control unit - J362- is integrated in the dash panel insert. In the event of control unit failure, the complete dash panel insert must be renewed.

- Removing and installing dash panel insert ⇒ [page 36](#) .



### 3.2 Removing and installing immobiliser reader coil

The immobiliser reader coil - D2- is joined to the ignition switch lock cylinder and cannot be renewed individually.

- Removing and installing lock cylinder ⇒ [page 99](#) .





## 4 Cigarette lighter, socket

⇒ [“4.1 Removing and installing cigarette lighter”, page 142](#)

⇒ [“4.2 Removing and installing 12 V socket”, page 142](#)

⇒ [“4.3 Removing and installing bulb for illuminating cigarette lighter”, page 142](#)

### 4.1 Removing and installing cigarette lighter

All the instructions and information for this manual are found in the workshop manual “Electrical System, General Information”. A link to this workshop manual is not possible at present for technical reasons. Please select the workshop manual “Electrical System, General Information” manually in ELSA.

### 4.2 Removing and installing 12 V socket

All the instructions and information for this manual are found in the workshop manual “Electrical System, General Information”. A link to this workshop manual is not possible at present for technical reasons. Please select the workshop manual “Electrical System, General Information” manually in ELSA.

### 4.3 Removing and installing bulb for illuminating cigarette lighter

The bulb for illuminating the cigarette lighter - L28- is an integral part of the cigarette lighter - U1- and can only be installed or removed together with the cigarette lighter - U1- .

– Removing and installing cigarette lighter - U1- ⇒ [page 142](#) .





## 97 – Wiring

### 1 Relay carriers, fuse holders, electronics boxes

⇒ [“1.1 Removing and installing electronics box \(E-box\)”, page 143](#)

⇒ [“1.2 Removing and installing relay and fuse holder in electronics box”, page 145](#)

⇒ [“1.3 Removing and installing relay and fuse holder behind dash panel on driver side”, page 147](#)

#### 1.1 Removing and installing electronics box (E-box)

Special tools and workshop equipment required

- ◆ Torque wrench - V.A.G 1410-

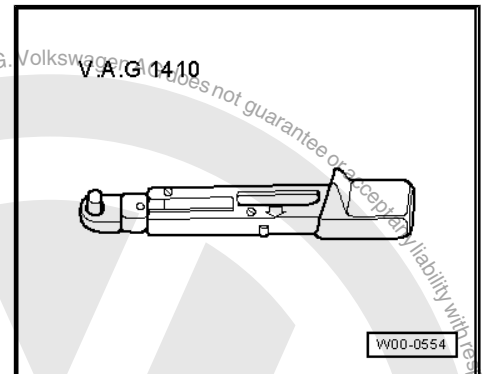

#### Caution

*To disconnect and reconnect the battery, the procedure described in the workshop manual should be strictly adhered to ⇒ [page 5](#).*

#### Removing

- Switch off ignition and all electrical consumers, and withdraw ignition key.
- Disconnect battery ⇒ [page 5](#).
- Release catches -arrows- and remove lid of electronics box -1-.
- Make a note of the assignment of electronics box connections.



#### Caution

- ◆ *Electrical components protected by the multiple fuse can fail!*
- ◆ *When the nuts for the wiring connections are undone, the multiple fuse will be damaged!*
- ◆ *The multiple fuse must be renewed after any loosening of the connections!*

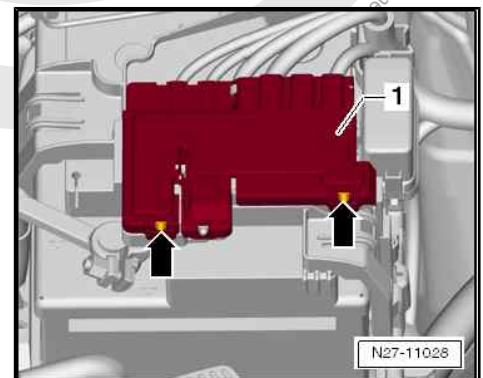



- Undo and remove all nuts of the wiring connections -arrows A- and remove wires from the connecting threads.
- Unscrew nut -arrow B-.
- Release the catches -arrow C- on each side of the electronics box holder and remove electronics Box together with holder upwards off the battery.

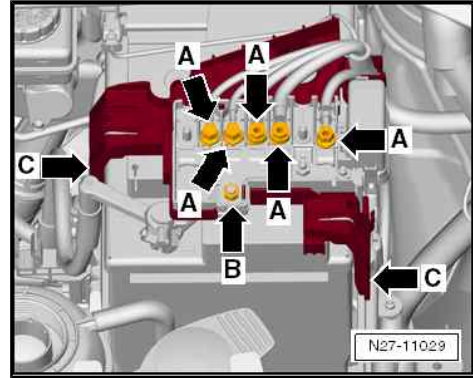

- Turn the electronics box holder over, release the catch -arrow- and remove electronics box from its holder.

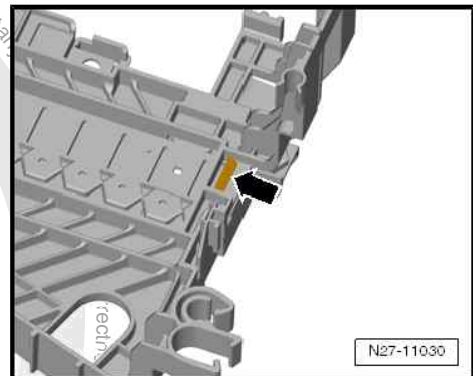

- Release locking lug -arrow- and pull fuse holder -1- upwards off the electronics box.
- Remove electronics box from vehicle.

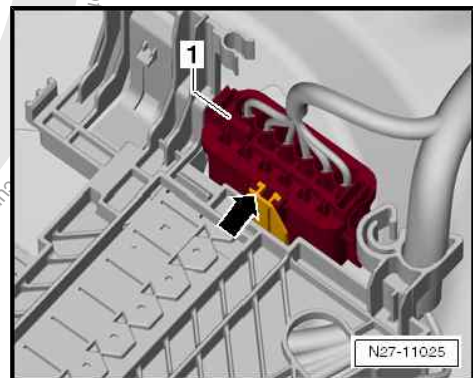

### Installing

Install in the reverse order of removal observing the following:

- Insert a new multiple fuse, and screw on nuts -arrows A- and -arrow B-.
- Connect battery => [page 5](#) .

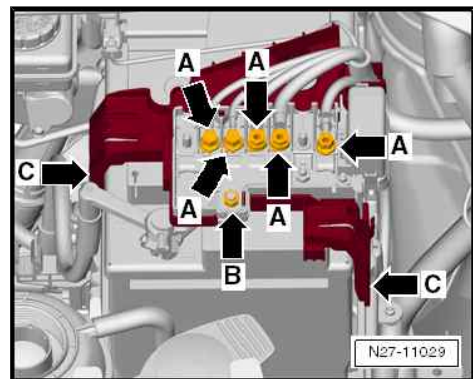

### Specified torques

Component	Specified torque
Nuts -arrows A- and -arrows B-	6 Nm



## 1.2 Removing and installing relay and fuse holder in electronics box

The fuse holder in the electronics box is attached to the side of the electronics box on the battery.

### Special tools and workshop equipment required

- ◆ Torque wrench - V.A.G 1410-

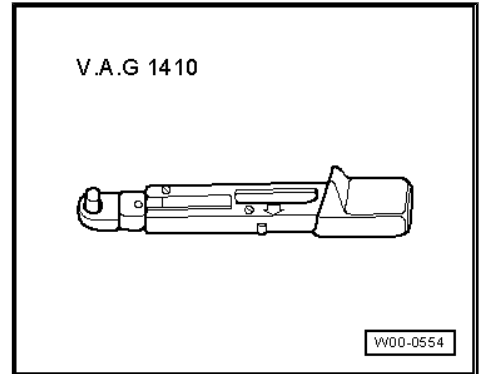

- ◆ Release tool set - VAS 1978/35-

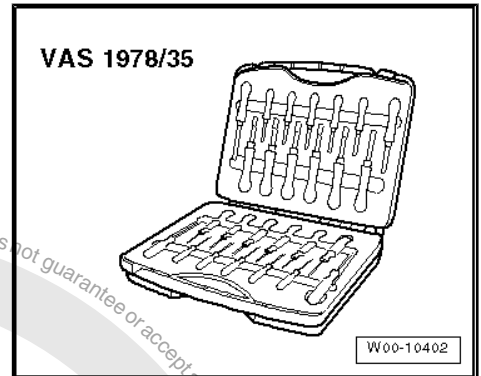

### Caution

*To disconnect and reconnect the battery, the procedure described in the workshop manual should be strictly adhered to ⇒ [page 5](#).*

### Removing

- Switch off ignition and all electrical consumers, and withdraw ignition key.
- Disconnect battery ⇒ [page 5](#).
- Remove electronics box on battery ⇒ [page 143](#).



### Caution

- ◆ *Electrical components protected by the multiple fuse can fail!*
- ◆ *When the nuts for the wiring connections are undone, the multiple fuse will be damaged!*
- ◆ *The multiple fuse must be renewed after any loosening of the connections!*





- Undo and remove the 2 nuts -arrows- and remove electroconductive plate -1- and multiple fuse -2- from electronics box.

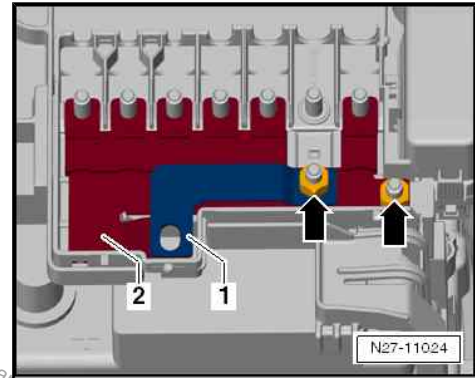

- Turn electronics box over, release locking lug -arrow- and pull fuse holder -1- upwards off the electronics box.

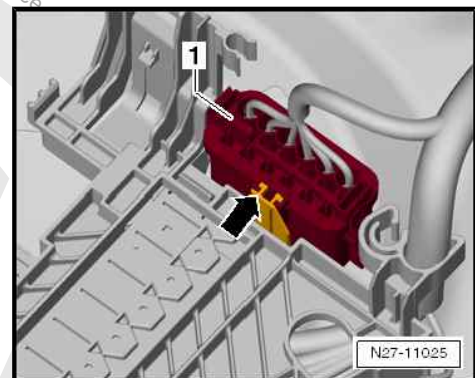

- Press catches at sides -arrows- and remove lid of fuse holder -1-.
- Make a note of the fuse assignment and remove all fuses from the fuse holder.

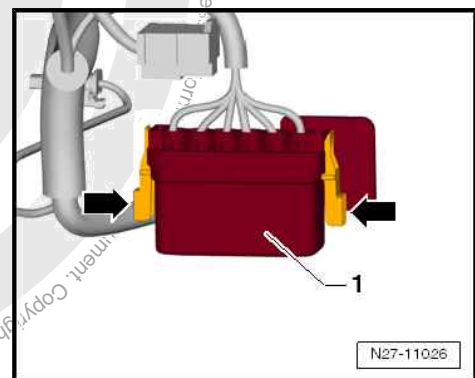

- Pull primary locking element -1- in -direction of arrow-, release all plug-in contacts with the correct release tool from the release tool set - VAS 1978/35- and then pull downwards out of the fuse holder.

**i** Note

The assignment of the correct release tool is shown in the table in the ⇒ operating instructions for the -VAS 1978/35-

**Installing**

Install in the reverse order of removal observing the following:

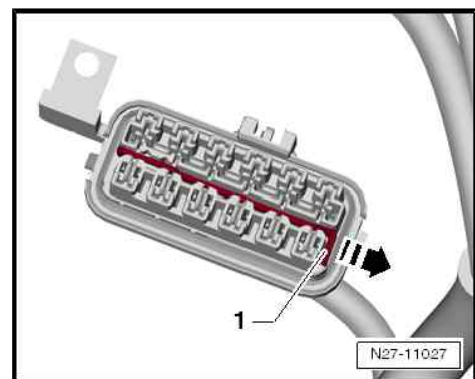





- Insert a new multiple fuse -2-, and screw on nuts -arrows-.
- Connect battery => [page 5](#) .

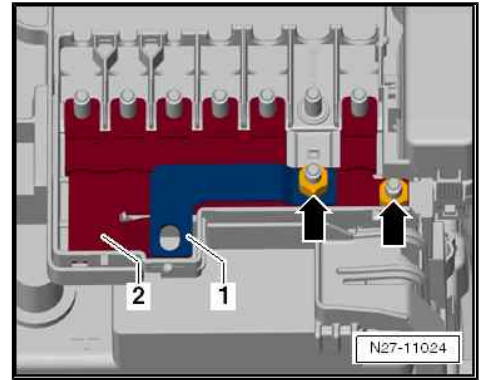

**Specified torques**

Component	Specified torque
Nuts -arrows-	6 Nm

**1.3 Removing and installing relay and fuse holder behind dash panel on driver side**

=> ["1.3.1 Removing and installing fuse holder behind dash panel on driver side", page 147](#)

=> ["1.3.2 Removing and installing fuse carrier on relay carrier", page 148](#)

=> ["1.3.3 Removing and installing dash panel relay carrier", page 150](#)

**1.3.1 Removing and installing fuse holder behind dash panel on driver side**

The fuse holder is located behind the right-hand side of the dash panel cover.

**Special tools and workshop equipment required**

- ◆ Torque wrench - V.A.G 1410-

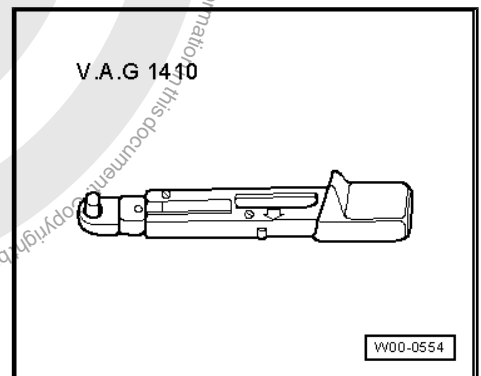

**Caution**

*To disconnect and reconnect the battery, the procedure described in the workshop manual should be strictly adhered to => [page 5](#) .*



### Note

- ◆ The illustrations show removal and installation of the fuse holder in an LHD vehicle.
- ◆ Removal and installation of the fuse holder in an RHD vehicle are analogous.

### Removing

- Switch off ignition and all electrical consumers, and withdraw ignition key.
- Disconnect battery ⇒ [page 5](#).
- Insert removal wedge - VAS 3409- or a screwdriver into opening -2- and lever the -1- dash panel cover off in -direction of arrow-.

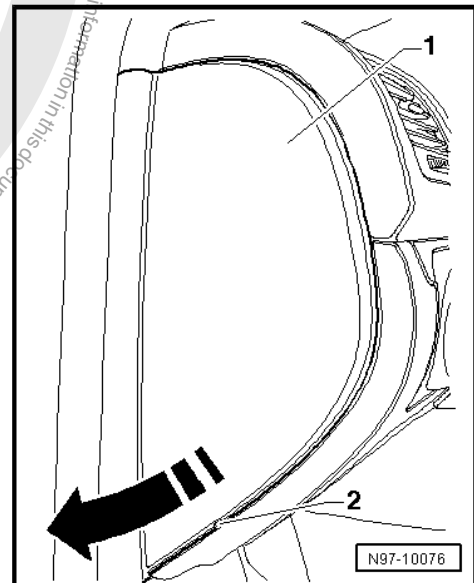

- Undo and remove screw -arrow- and pull fuse holder -1- together with carrier -2- upwards off the body.

### Installing

Install in the reverse order of removal observing the following:

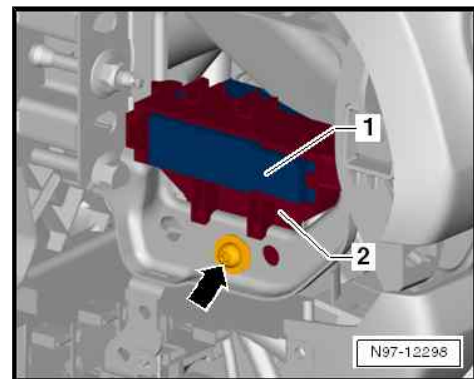

### Specified torques

Component	Specified torque
Securing bolt	1.5 Nm

## 1.3.2 Removing and installing fuse carrier on relay carrier

The fuse carrier is located behind the trim in the driver footwell, under the relay carrier.

### Special tools and workshop equipment required



- ◆ Torque wrench - V.A.G 1410-

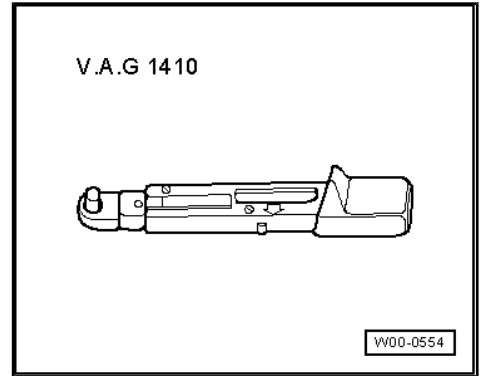

- ◆ Release tool set - VAS 1978/35-

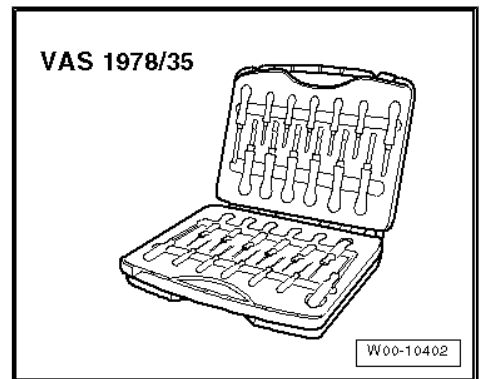

 **Caution**

*To disconnect and reconnect the battery, the procedure described in the workshop manual should be strictly adhered to ⇒ [page 5](#).*

-  **Note**
- ◆ *The illustrations show removal and installation of the fuse carrier in an LHD vehicle.*
  - ◆ *Removal and installation of the fuse carrier in an RHD vehicle are analogous.*

#### Removing

- Switch off ignition and all electrical consumers, and withdraw ignition key.
- Disconnect battery ⇒ [page 5](#).
- Remove trim in footwell ⇒ General body repairs, interior; Rep. gr. 68 ; Storage compartments/covers; Fitting locations overview - storage compartments/covers .
- Remove lower A-pillar trim on driver side ⇒ General body repairs, interior; Rep. gr. 70 ; Interior trims; Assembly overview - A-pillar trim .



- Undo screws -arrows- and pull fuse carrier -1- out of relay carrier, taking connected wiring lengths into consideration.
- Make a note of the fuse assignment and remove all fuses from the fuse carrier.
- Pull primary locking elements -1-, release all plug-in contacts with the correct release tool from the release tool set - VAS 1978/35- and then pull downwards out of the fuse carrier.



**Note**

The assignment of the correct release tool is shown in the table in the ⇒ operating instructions for the -VAS 1978/35-

**Installing**

Install in the reverse order of removal observing the following:

**Specified torques**

Component	Specified torque
Securing bolts securing fuse carrier to relay carrier	4 Nm

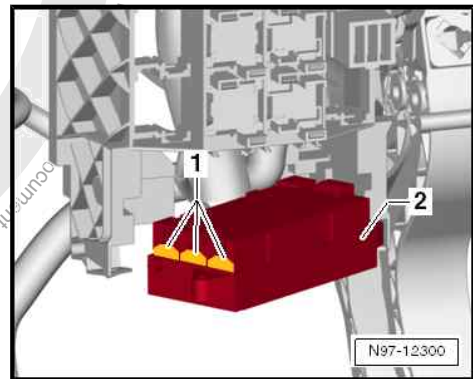
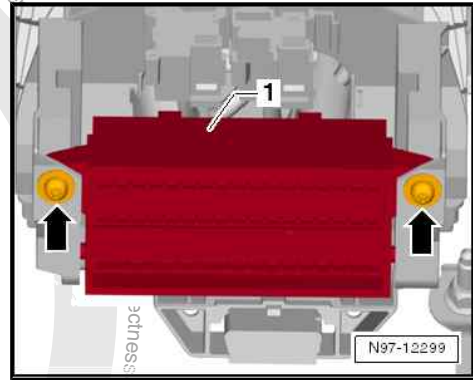

### 1.3.3 Removing and installing dash panel relay carrier

The dash panel relay carrier is built into the driver side footwell, underneath the dash panel.

**Special tools and workshop equipment required**

- ◆ Torque wrench - V.A.G 1410-

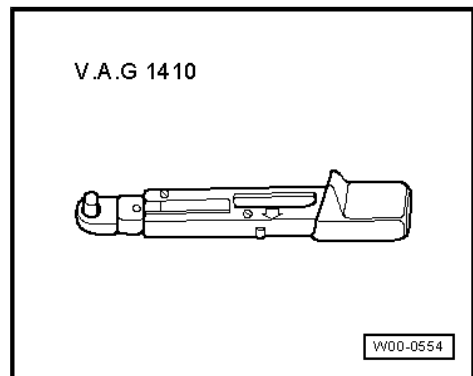



- ◆ Release tool set - VAS 1978/35-

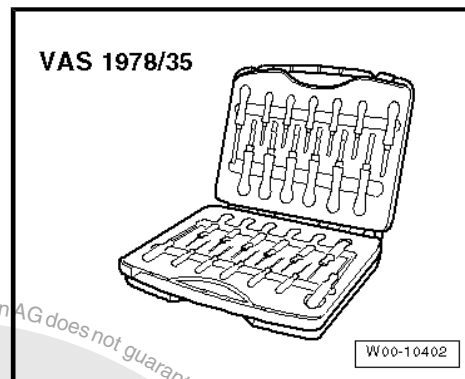

### Caution

*To disconnect and reconnect the battery, the procedure described in the workshop manual should be strictly adhered to ⇒ [page 5](#).*



### Note

- ◆ *The illustrations show removal and installation of the relay carrier in an LHD vehicle.*
- ◆ *Removal and installation of the relay carrier in an RHD vehicle are analogous.*

### Removing

- Switch off ignition and all electrical consumers, and withdraw ignition key.
- Disconnect battery ⇒ [page 5](#).
- Remove trim in footwell ⇒ General body repairs, interior; Rep. gr. 68 ; Storage compartments/covers; Fitting locations overview - storage compartments/covers .
- Remove lower A-pillar trim on driver side ⇒ General body repairs, interior; Rep. gr. 70 ; Interior trims; Assembly overview - A-pillar trim .
- Remove fuse holder from relay carrier ⇒ [page 148](#) .
- Remove onboard supply control unit - J519- ⇒ [page 153](#) .



### Note

*For reasons of clarity, the relay carrier is shown from the rear in the following illustrations.*



- Remove the 3 nuts (width across flats 10 mm) -arrows- and pull relay carrier -1- off threaded pins, taking connected wiring lengths into consideration.

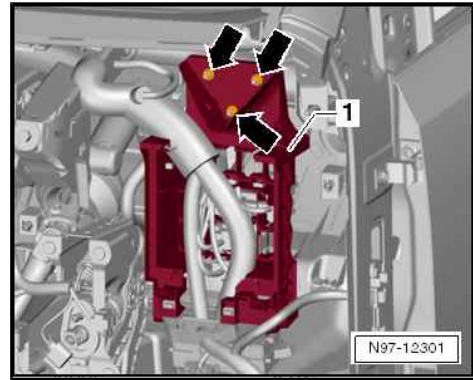

- Cut the cable tie -arrow- and unclip cable fuse -1- from relay carrier.
- Make a note of the assignment of the relays in the holder.

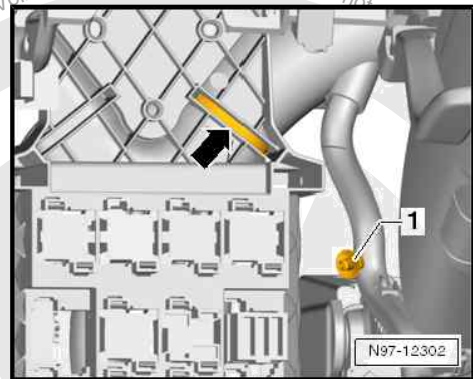

- Release all the connectors on rear of relay carrier -arrows- and pull them towards the rear out of the relay carrier together with the plugged-in relays.

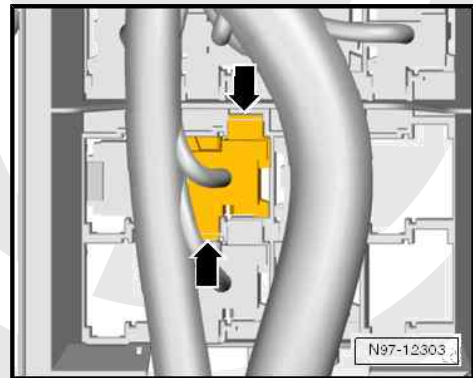

- Release diagnostic connector -1- in -direction of arrow-, and pull it out of relay carrier -2-.
- Remove relay carrier -2- from vehicle.

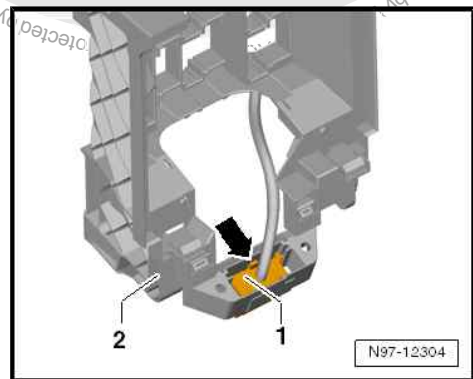

### Installing

Install in the reverse order of removal observing the following:



#### Note

*Attach all cable ties cut during removal and all cable fuses in their original positions*

### Specified torques

Component	Specified torque
Securing bolts securing relay carrier to body	4.5 Nm





## 2 Select Control units

⇒ ["2.1 Removing and installing onboard supply control unit J519"](#), page 153

⇒ ["2.2 Removing and installing data bus diagnostic interface J533"](#), page 155

### 2.1 Removing and installing onboard supply control unit - J519-

Removing and installing onboard supply control unit - J519-  
⇒ [page 154](#)

Renewing onboard power supply control unit ⇒ [page 155](#)

Coding onboard supply control unit ⇒ [page 155](#)

Adapting onboard supply control unit ⇒ [page 155](#)

Performing final control diagnosis of onboard supply control unit  
⇒ [page 155](#)

#### General description:

The onboard supply control unit - J519- is fastened to the rear of the relay carrier in the driver side footwell and performs the following functions in the vehicle.

- ◆ EFP relay
- ◆ Electrical load management
- ◆ Driver door contact
- ◆ Transfer of dimming information on the CAN bus
- ◆ Windscreen wiper speeds I, II and intermittent wiper
- ◆ Reading in of sender unit button for emergency braking function
- ◆ Operation of hazard warning flasher, turning signals, emergency braking flasher
- ◆ Horn
- ◆ Brake lights
- ◆ Terminal detection, terminal 15; S-contact
- ◆ Heated rear window
- ◆ Rear lid release without central locking
- ◆ Terminal 30, interior light
- ◆ CAN bus drive
- ◆ CAN diagnosis
- ◆ CAN gateway

The following functions can be adapted:

- ◆ Adapt remote control unit key
- ◆ Check remote control unit key
- ◆ Deactivate factory mode





#### Note

- ◆ *If the onboard supply control unit - J519- is to be renewed, the procedure for "replacing onboard supply control unit"  
⇒ [page 155](#) must always be carried out for reading the codes stored in the control unit.*
- ◆ *The following illustrations show removal on a LHD vehicle. Removal and installation of onboard supply control unit on an RHD vehicle are performed using the corresponding mirror-image procedure.*

#### Removing



#### Note

*If the onboard supply control unit is to be renewed, first carry out the work involved in "Renewing onboard supply control unit"  
⇒ [page 155](#) .*

- Switch off ignition and all electrical consumers, and withdraw ignition key.



#### Note

*The following illustration shows the installed onboard supply control unit on the rear of the relay carrier.*





- Pull the two clips -1- of the primary locking system downwards in -direction of arrow- and pull the two connectors -A- and -B- off the onboard supply control unit - J519- -2-.
- Press the two locking buttons -3- and pull onboard supply control unit - J519- -2- out of the holder, starting at the bottom.

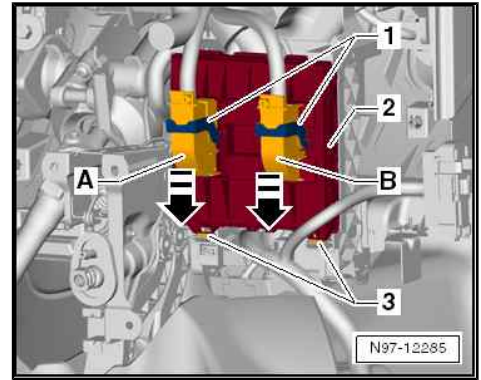

### Installing

Install in the reverse order of removal, observing the following:

- First insert the onboard supply control unit - J519- -2- into the top mountings -1- on the holder and then push unit into catches at bottom -3- until it engages audibly.

### Replacing onboard power supply control unit

This programme helps you to replace the onboard supply control unit. After replacement, the control unit must be coded online, after which the factory mode must be deactivated and the data bus diagnostic interface - J533- recoded. The programmes will be entered in the test schedule.

- Renew onboard power supply control unit ⇒ Vehicle diagnostic tester.

### Coding onboard supply control unit

- Coding onboard supply control unit ⇒ Vehicle diagnostic tester.

### Adapting onboard supply control unit

The following components can be adapted with this function:

- ◆ Adapting remote control unit key
- ◆ Checking remote control unit key
- ◆ Deactivating factory mode

### Final control diagnosis of onboard supply control unit

A final control test of the following components can be carried out with this function:

- ◆ Lighting
- ◆ Windscreen wiper/wash system
- ◆ Heating for windscreen, rear window, seat and mirror
- ◆ Central locking system
- ◆ Warning, monitoring and sliding/tilting sunroof
- ◆ Windows
- Perform final control diagnosis of onboard supply control unit ⇒ Vehicle diagnostic tester.

## 2.2 Removing and installing data bus diagnostic interface - J533-

The functions of the data bus diagnostic interface - J533- are integrated in the onboard supply control unit - J519- . The data bus diagnostic interface - J533- cannot be replaced separately.

- Removing and installing onboard supply control unit - J519- ⇒ [page 153](#) .



### 3 Connectors

⇒ ["3.1 Repairing electrical wiring harnesses and plug-in connections", page 156](#)

#### 3.1 Repairing electrical wiring harnesses and plug-in connections

All instructions and notes regarding this chapter are available under ⇒ Electrical System, General Information; Rep. gr. 97 ; Vehicle diagnosis, testing and information systems .





## 4 Vehicle diagnosis, testing and information systems

All instructions and notes regarding this chapter are available under ⇒ **Electrical System, General Information; Rep. gr. 97 ; Vehicle diagnosis, testing and information systems .**

⇒ **[“4.1 Online system test”, page 157](#)**

### 4.1 Online system test

The following processes are performed with this test program:

- ◆ System test for online connection
- ◆ Check of user authorization
- ◆ Test for correct line connection to Volkswagen database

Prerequisite: tester must have an online connection (network connection):

- Online system test ⇒ Vehicle diagnostic tester.

