



Workshop Manual

Polo 2014 ➤

up! 2012 ➤

up! 2017 ➤

5-speed manual gearbox 0CF

Edition 06.2018

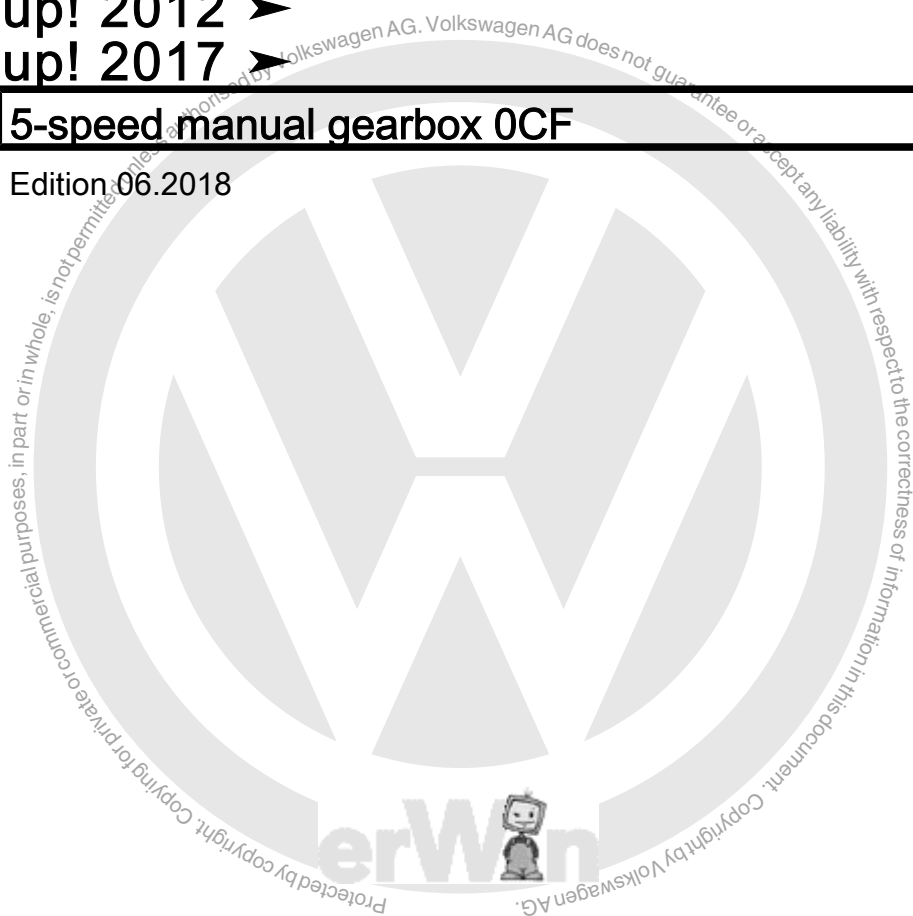



List of Workshop Manual Repair Groups

Repair Group

- 00 - Technical data
- 30 - Clutch
- 34 - Controls, housing
- 35 - Gears, shafts
- 39 - Final drive - differential



Technical information should always be available to the foremen and mechanics, because their careful and constant adherence to the instructions is essential to ensure vehicle road-worthiness and safety. In addition, the normal basic safety precautions for working on motor vehicles must, as a matter of course, be observed.

All rights reserved.
No reproduction without prior agreement from publisher.



Contents

00 - Technical data	1
1 Safety information	1
1.1 Safety measures when working on vehicles with a start/stop system	1
2 Identification	2
2.1 Gearbox identification	2
3 Repair instructions	3
3.1 General repair instructions	3
4 Technical data	6
4.1 Allocation gearbox - engine	6
4.2 Capacities	8
4.3 Calculation of gear ratios	8
5 Overview - power transmission	9
6 Electrical components	11
6.1 Overview of fitting locations - electrical components	11
30 - Clutch	13
1 Clutch operation	13
1.1 Overview of fitting locations – clutch mechanism	13
1.2 Assembly overview - pedal cluster	16
1.3 Assembly overview - clutch hydraulics	20
1.4 Assembly overview - clutch release mechanism	24
1.5 Removing and installing bearing bush	25
1.6 Removing and installing clutch pedal	26
1.7 Removing and installing over-centre spring	28
1.8 Removing and installing extension spring	30
1.9 Removing and installing mounting bracket	31
1.10 Removing and installing clutch master cylinder	39
1.11 Removing and installing clutch slave cylinder	41
1.12 Removing and installing lines for clutch mechanism	43
1.13 Bleeding clutch mechanism	46
1.14 Removing and installing clutch pedal switch F36	47
1.15 Checking clutch master cylinder and clutch slave cylinder	48
1.16 Removing and installing clutch position sender G476	48
1.17 Repairing clutch release mechanism	51
2 Clutch	53
2.1 Assembly overview - clutch	53
2.2 Removing and installing clutch	54
34 - Controls, housing	58
1 Selector mechanism	58
1.1 Installation position - selector mechanism	58
1.2 Overview - selector mechanism	60
1.3 Assembly overview - gear knob and cover	61
1.4 Assembly overview - Gear lever and selector housing	62
1.5 Assembly overview - Selector cables	65
1.6 Removing and installing gear knob	67
1.7 Emblem identification	69
1.8 Removing and installing selector mechanism	69
1.9 Repairing selector mechanism	72
1.10 Adjusting selector mechanism	76
1.11 Checking selector mechanism	78
1.12 Dismantling and assembling selector mechanism	78



1.13	Removing and installing selector cable	82
1.14	Renewing selector shaft seal	83
2	Removing and installing gearbox	85
2.1	Specified torques for gearbox	85
2.2	Removing gearbox	85
2.3	Installing gearbox	101
3	Assembly mountings	110
3.1	Assembly overview - assembly mountings	110
4	Transporting gearbox	114
5	Dismantling and assembling gearbox	115
5.1	Schematic overview - gearbox	115
5.2	Assembly overview - gearbox	116
5.3	Assembly overview - clutch housing	117
5.4	Assembly overview - selector unit	118
5.5	Assembly overview - shafts, differential, selector mechanism	119
5.6	Removing and installing selector unit with gearbox installed	119
5.7	Renewing selector shaft sleeve	123
5.8	Dismantling and assembling gearbox	124
6	Gearbox housing, clutch housing	131
6.1	Assembly overview - gearbox housing and clutch housing	131
7	Securing to engine and gearbox support	133
8	Gear oil	134
8.1	Checking gear oil level	134
8.2	Draining and filling gear oil	134
35 - Gears, shafts		136
1	Input shaft	136
1.1	Assembly overview - input shaft	136
1.2	Dismantling and assembling input shaft	138
1.3	Adjusting input shaft	144
1.4	Renewing input shaft seal	149
2	Output shaft	151
2.1	Assembly overview - output shaft	151
2.2	Dismantling and assembling output shaft	154
2.3	Adjusting output shaft	165
3	Reverse shaft	170
3.1	Removing and installing reverse shaft	170
39 - Final drive - differential		171
1	Oil seals	171
1.1	Overview of fitting locations - seals	171
1.2	Renewing left seal	172
1.3	Renewing right oil seal	173
2	Differential	174
2.1	Assembly overview - differential	174
2.2	Dismantling and assembling differential	175
2.3	Adjusting differential	182
3	Adjustment overview	185



00 – Technical data

1 Safety information

(VRL011884; Edition 06.2018)

⇒ [1.1 Safety measures when working on vehicles with a start/stop system", page 1](#)

1.1 Safety measures when working on vehicles with a start/stop system



WARNING

Risk of injury due to automatic start of engine on vehicles with a start/stop system.

- ◆ *Deactivate the start/stop system when working on vehicle. Switch off ignition.*
- ◆ *Switch on the ignition briefly only if required.*



2 Identification

⇒ "2.1 Gearbox identification", page 2

2.1 Gearbox identification

Code letters and production date -arrow 1- manual gearbox
OCF-arrow 2-

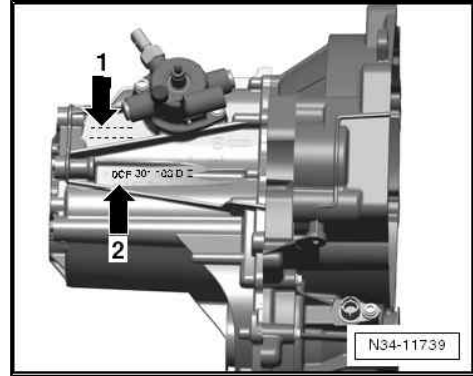

Manual gearbox OCF -arrow 2-

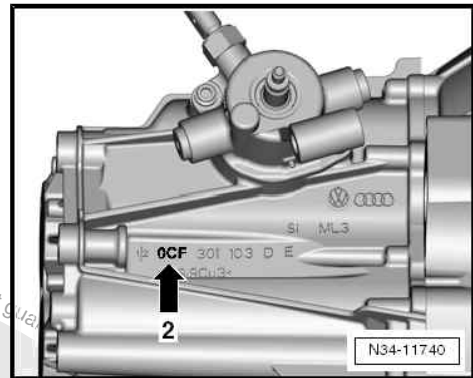

Codes and production date of gearbox

Example:	NNE	15	12	1
	Codes	Day	Month	Year (2011) of manufacture

Additional data provide information about the production facility.



Note

The gearbox code is also included on the vehicle data stickers.

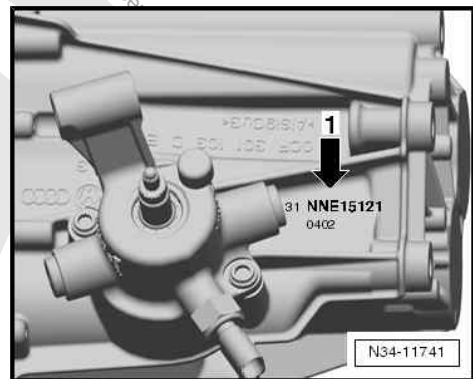



3 Repair instructions

⇒ **“3.1 General repair instructions”, page 3**

3.1 General repair instructions

To ensure flawless and successful gearbox repairs, the greatest care and cleanliness as well as the use of good and proper tools are essential. Of course, the basic rules for safety also apply during repair work.

A number of general notes on the individual repair procedures, which can otherwise be found in the relevant sections of the manual, are summarised here. They apply for this particular workshop manual.

Special tool

For a complete list of special tools used in this workshop manual, see ⇒ Workshop equipment and special tools .

Gearbox

- ◆ When installing the manual gearbox, ensure that the dowel sleeves between the engine and gearbox are correctly seated.
- ◆ When installing mounting brackets or waxed components, clean the contact surfaces. Contact surfaces must be free of wax and grease.
- ◆ Allocate bolts and other components using the ⇒ Electronic parts catalogue (ETKA) .
- ◆ If the gearbox is repaired, fill with gear oil.

Gaskets and seals

After removing gaskets and seals, always inspect contact surfaces of housing and shaft for burrs resulting from removal or for other signs of damage.

- ◆ Thoroughly clean joint surfaces and apply sealant .
- ◆ Allocation ⇒ Electronic parts catalogue (ETKA)
- ◆ Before installing radial oil seals, half-fill space between sealing lips with sealing grease -arrow-.
- ◆ Allocate grease using ⇒ Electronic parts catalogue (ETKA) .
- ◆ The open side of the oil seals faces toward the side with fluid filling.
- ◆ Lightly oil O-rings before installing; this prevents the rings being crushed when inserted.

Sealant

- ◆ Thoroughly clean housing joint surfaces before applying sealant .
- ◆ Apply sealant uniformly and not too thickly.
- ◆ Allocation ⇒ Electronic parts catalogue (ETKA) .
- ◆ Breather holes must remain free of sealant .

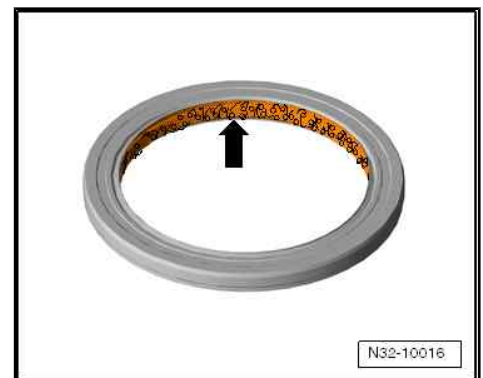



Locking devices

- ◆ Renew retaining rings.
- ◆ Do not overstretch retaining rings.
- ◆ Retaining rings must locate properly in grooves.
- ◆ Renew spring pins. Installation position: slot must be in line with direction of force.

Nuts and bolts

- ◆ Loosen and tighten securing bolts and nuts for covers and housings alternately and diagonally.
- ◆ Do not cant especially delicate parts, such as clutch pressure plates. Loosen and tighten bolts and nuts alternately and in stages.
- ◆ Specified torques given are for uncoiled nuts, bolts and screws.
- ◆ Renew self-locking bolts and nuts after each removal.
- ◆ Ensure with threaded connections that contact surfaces as well as nuts and bolts are re waxed only after assembly, if necessary.
- ◆ Use a thread chaser to clear residual locking fluid from all threaded holes into which self-locking bolts are to be screwed. Otherwise there is a danger of bolts shearing when subsequently being removed.
- ◆ Check pitch of thread, to ensure correct thread chaser is used to clean threads and to ensure the threads are not damaged.

Bearings

- ◆ Lubricate all bearings with gear oil before installing.
- ◆ Install new tapered roller bearings as supplied and do not lubricate additionally.
- ◆ Install needle bearings with lettered side (thicker metal) towards fitting tool.
- ◆ Tapered roller bearings fitted to one shaft must be renewed as a set. Use same make of bearings.
- ◆ Heat inner races to about 100°C with the inductive heater - VAS 6414- before installing.
- ◆ Do not interchange outer or inner races of bearings of the same size. The bearings are matched in pairs.

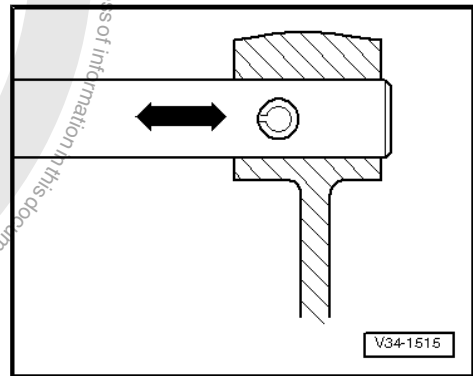
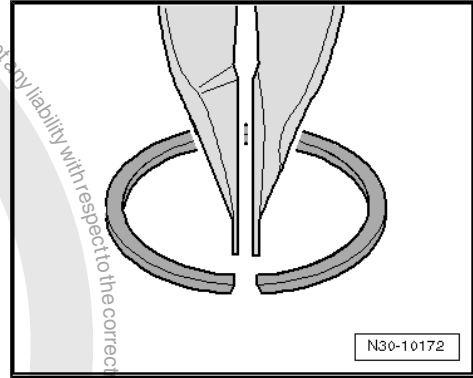



Shims

- ◆ Measure shims at several points with a micrometer. The various tolerances make it possible to achieve the exact shim thickness required.
- ◆ Check for burrs and damage.
- ◆ Install only flawless shims.

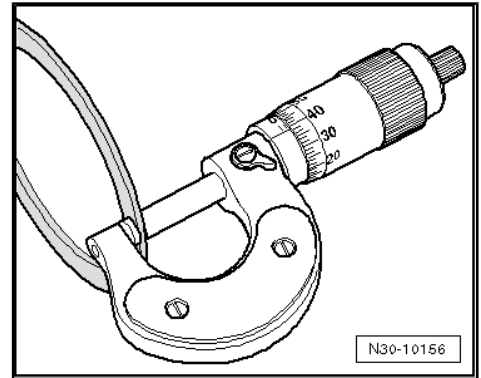

Synchro-rings

- ◆ Do not interchange them. When reusing synchro-rings, always fit to the same synchromeshed gear.
- ◆ Check for wear and renew if necessary.
- ◆ Check grooves -arrow 1- of synchro-ring -A- and inner ring for flat spots (worn grooves).
- ◆ If synchro-rings are coated, coating must not be damaged.
- ◆ If an intermediate ring -B- is installed, check the outer friction surface -arrow 2- and inner friction surface -arrow 3- of this intermediate ring for »scoring«, »signs of abnormal wear« and »blue discolouration (due to overheating)«.
- ◆ Check the cone of the synchromeshed gear for »scoring« and »signs of abnormal wear«.
- ◆ Moisten synchromesh mechanism with gear oil before installing.

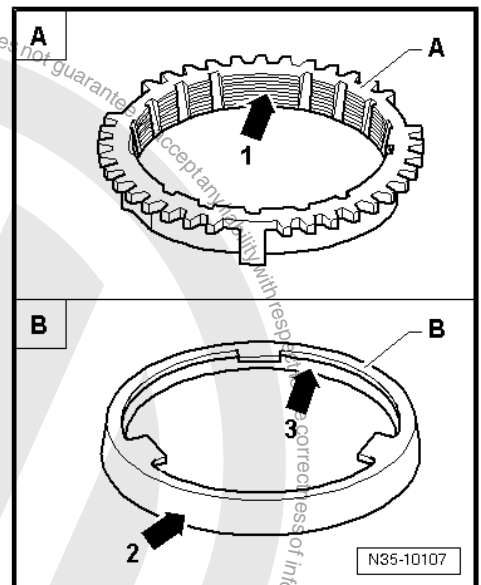

Gears and synchro-hubs

- ◆ Before installing, clean and heat with the inductive heater - VAS 6414- to maximum 100°C.
- ◆ Observe installation position

Synchromeshed gears

- ◆ After assembly, check synchromeshed gears for slight play, or for freedom of movement.

Clutch operation

Disconnect battery earth strap ⇒ Electrical system; Rep. gr. 27 ; Battery; Disconnecting and connecting battery .

When reconnecting battery, refer to ⇒ Electrical system; Rep. gr. 27 ; Battery; Disconnecting and connecting battery .

Clutch

- ◆ Ensure that the pressure plate does not cant: loosen and tighten bolts alternately and diagonally and in several gradual stages.
- ◆ In order to reduce the smell of a burned clutch, the clutch housing as well as the stopping face of the flywheel must be thoroughly cleaned with a cloth.



4 Technical data

⇒ "4.1 Allocation gearbox - engine", page 6 .

⇒ "4.2 Capacities", page 8 .

⇒ "4.3 Calculation of gear ratios", page 8 .

4.1 Allocation gearbox - engine

⇒ "4.1.1 Allocation gearbox - engine, up!", page 6 .

⇒ "4.1.2 Allocation gearbox - engine, Polo", page 7 .

4.1.1 Allocation gearbox - engine, up!

Manual gearbox		5-speed, 0CF		
Codes		NTK	NTL	NTM
Manufactured	from to	08.11 10.13	08.11 10.13	08.11 10.13
Allocation	Engine	1.0 l - 44 KW	1.0 l - 55 KW	1.0 l - 44 KW
Ratio Z2 : Z1	Final drive	74 : 19 = 3.895	75 : 18 = 4.1666	74 : 19 = 3.895

Glean following data from ⇒ Electronic parts catalogue (ETKA) :

- ◆ Individual gear ratios
- ◆ Gear oil
- ◆ Clutch allocation

Manual gearbox		5-speed, 0CF		
Codes		NTN	NZC	NZD
Manufactured	from to	08.11 10.13	02.12 10.13	02.12 10.13
Allocation	Engine	1.0 l - 55 KW	1.0 l - 44 KW	1.0 l - 55 KW
Ratio Z2 : Z1	Final drive	75 : 18 = 4.1666	74 : 19 = 3.895	75 : 18 = 4.1666

Glean following data from ⇒ Electronic parts catalogue (ETKA) :

- ◆ Individual gear ratios
- ◆ Gear oil
- ◆ Clutch allocation

Manual gearbox		5-speed, 0CF		
Codes		NZE	NZF	QCF
Manufactured	from to	02.12 10.13	02.12 10.13	10.13
Allocation	Engine	1.0 l - 44 KW	1.0 l - 50 KW 1.0 l - 55 KW	1.0 l - 44 KW
Ratio Z2 : Z1	Final drive	74 : 19 = 3.895	75 : 18 = 4.1666	74 : 19 = 3.895

Glean following data from ⇒ Electronic parts catalogue (ETKA) :

- ◆ Individual gear ratios
- ◆ Gear oil



◆ Clutch allocation

Manual gearbox		5-speed, 0CF		
Codes		QCG	QCH	QCJ
Manufactured	from to	10.13	10.13	10.13
Allocation	Engine	1.0 l - 55 KW	1.0 l - 44 KW	1.0 l - 50 KW 1.0 l - 55 KW
Ratio Z2 : Z1	Final drive	75 : 18 = 4.1666	74 : 19 = 3.895	75 : 18 = 4.1666

Glean following data from ⇒ Electronic parts catalogue (ETKA) :

- ◆ Individual gear ratios
- ◆ Gear oil
- ◆ Clutch allocation

Manual gearbox		5-speed, 0CF		
Codes		RNY, UCZ	RNZ, UDA	
Manufactured	from to	05.16	05.16	
Allocation	Engine	1.0 l - 44 KW 1.0 l - 55 KW	1.0 l - 44 KW 1.0 l - 55 KW	
Ratio Z2 : Z1	Final drive	74 : 19 = 3.895	74 : 19 = 3.895	

Glean following data from ⇒ Electronic parts catalogue (ETKA) :

- ◆ Individual gear ratios
- ◆ Gear oil
- ◆ Clutch allocation

4.1.2 Allocation gearbox - engine, Polo

Manual gearbox		5-speed, 0CF		
Codes		QAB	QAC	QAD
Manufactured	from to	01.14	01.14	01.14
Allocation	Engine	1.0 l - 44 KW	1.0 l - 44 KW	1.0 l - 55 KW
Ratio Z2 : Z1	Final drive	77 : 16 = 4.813	77 : 16 = 4.813	77 : 16 = 4.813

Glean following data from ⇒ Electronic parts catalogue (ETKA) :

- ◆ Individual gear ratios
- ◆ Gear oil
- ◆ Clutch allocation

Manual gearbox		5-speed, 0CF		
Codes		QAE		
Manufactured	from to	01.14		



Manual gearbox		5-speed, OCF	
Codes		QAE	
Allocation	Engine	1.0 l - 55 KW	
Ratio Z2 : Z1	Final drive	77 : 16 = 4.813	

Glean following data from ⇒ Electronic parts catalogue (ETKA) :

- ◆ Individual gear ratios
- ◆ Gear oil
- ◆ Clutch allocation

4.2 Capacities

Capacity of manual gearbox (gearbox completely dismantled)	1.3 l
Capacity of manual gearbox (if oil leaked during work on assembled gearbox, drive shaft oil seals were renewed or if gearbox was removed and reinstalled)	1.1 l

4.3 Calculation of gear ratios

Example:

	5th gear	Final drive
Drive gear	ZG ₁ = 46	ZA ₁ = 24
Driven gear	ZG ₂ = 33	ZA ₂ = 70

$$i = ZG_2 : ZG_1 \quad 1)$$

$$i_G = \text{Gear ratio} = ZG_2 : ZG_1 = 33 : 46 = 0.717$$

$$i_A = \text{Final drive ratio} = ZA_2 : ZA_1 = 70 : 24 = 2.917$$

$$i_{\text{total}} = \text{overall ratio} = i_G \times i_A = 0.717 \times 2.917 = 2.091$$

1) Z₁ = No. of teeth on driving gear, Z₂ = No. of teeth on driven gear



5 Overview - power transmission

Designation:

-Arrows- point in direction of travel.

- 1 - Engine
- 2 - Clutch
- 3 - Manual gearbox
- 4 - Input shaft
- 5 - Output shaft
- 6 - Differential

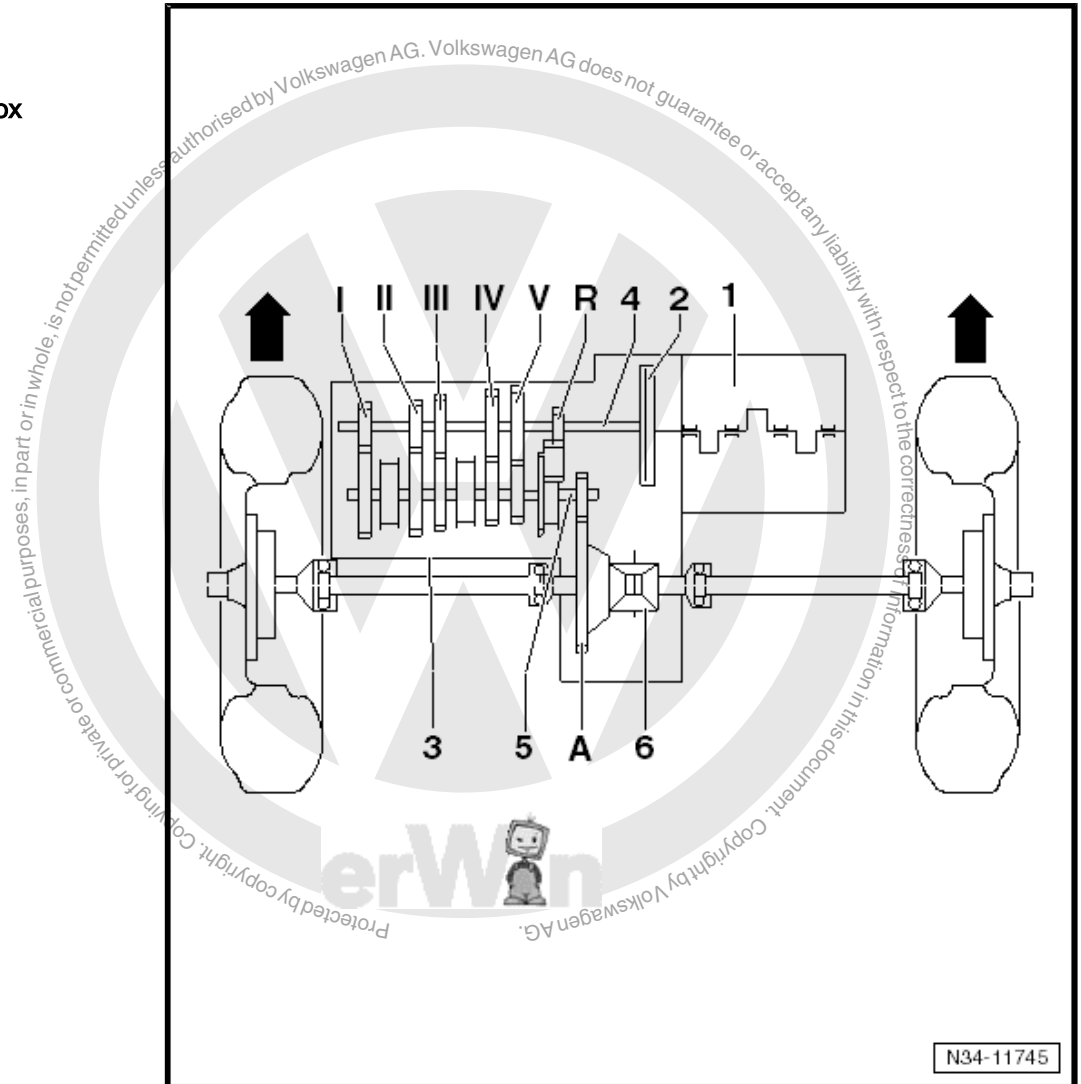

Ratio

-Arrows- point in direction of travel.



- I - 1st gear
- II - 2nd gear
- III - 3rd gear
- IV - 4th gear
- V - 5th gear
- R - Reverse gear
- A - Final drive

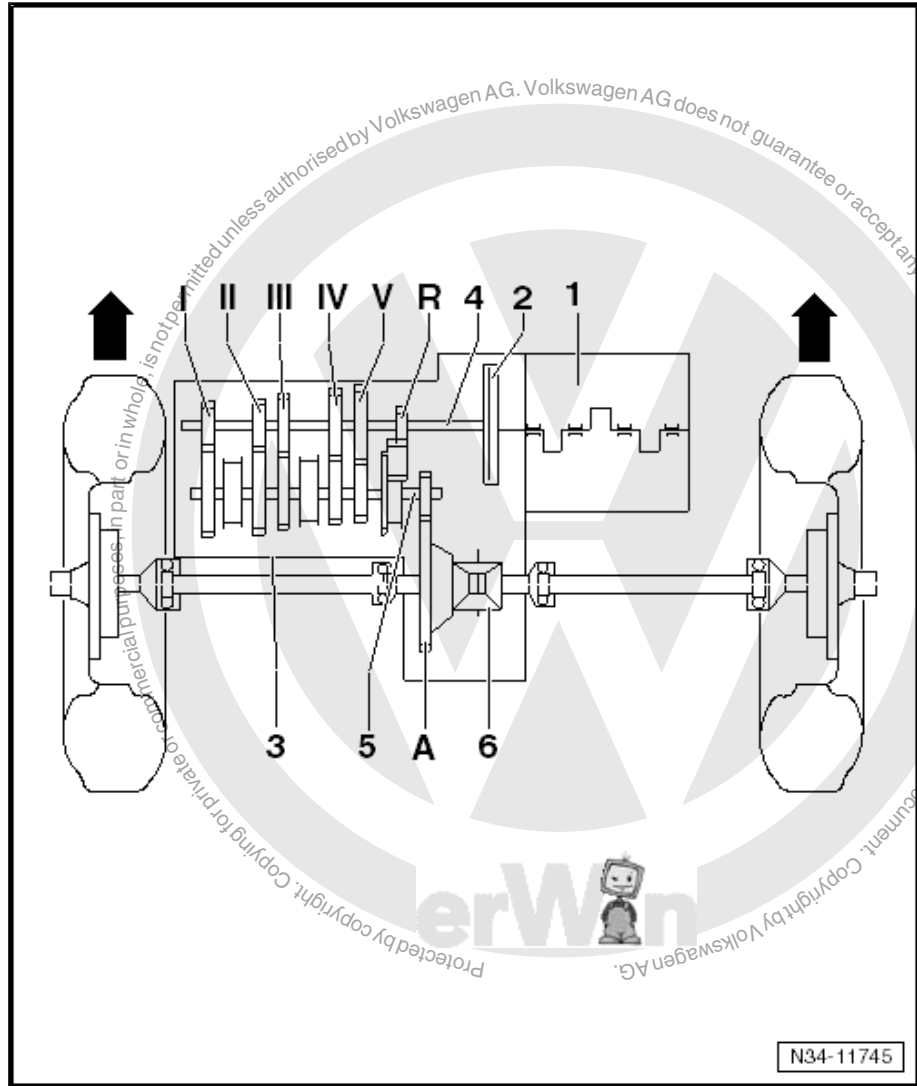



6 Electrical components

⇒ [“6.1 Overview of fitting locations - electrical components”, page 11](#)

6.1 Overview of fitting locations - electrical components

⇒ [“6.1.1 Overview of fitting locations – electrical components, manual gearbox”, page 11](#)

⇒ [“6.1.2 Overview of fitting locations – electrical components, clutch mechanism, up!”, page 11](#)

⇒ [“6.1.3 Overview of fitting locations – electrical components, clutch mechanism, Polo”, page 12](#)

6.1.1 Overview of fitting locations – electrical components, manual gearbox

1 - Gearbox neutral position sender - G701-

- Location: beneath selector unit
- Removing and installing
⇒ [page 119](#)

2 - Reversing light switch - F4-

- Location: on selector unit
- Removing and installing
⇒ [page 118](#)

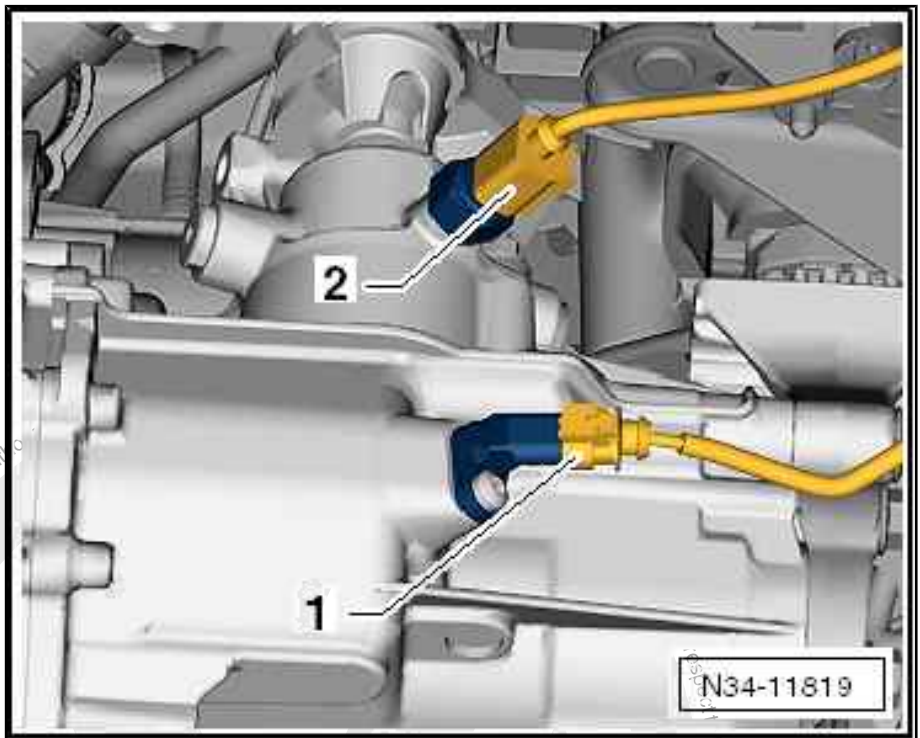

6.1.2 Overview of fitting locations – electrical components, clutch mechanism, up!

Clutch position sender - G476-

Location: in passenger compartment on clutch master cylinder.

Held in position by retainer -arrow A- and -arrow B-

Removing and installing clutch position sender - G476-

⇒ [page 48](#) .

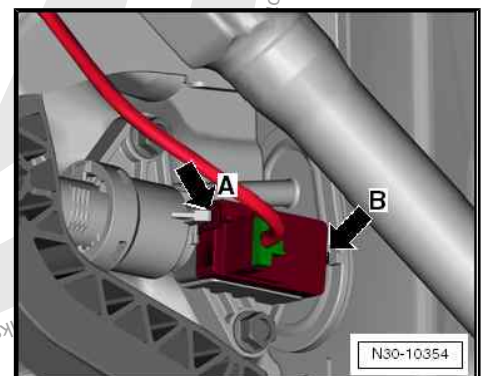



Clutch pedal switch - F36- (item -2-)

Location: in passenger compartment on mounting bracket for clutch pedal

Connector -1- is connected; plunger -3- makes contact with clutch pedal -4-.

Removing and installing clutch pedal switch - F36- => [page 47](#)

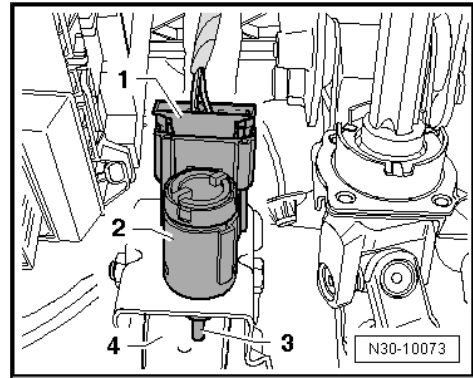

6.1.3 Overview of fitting locations – electrical components, clutch mechanism, Polo

Clutch position sender - G476- (-arrow A- and -arrow B-)

Fitting location:

In engine compartment beneath supply hose -1- on clutch cylinder -2- above line -3-.

Removing and installing clutch position sender - G476- => [page 49](#) .

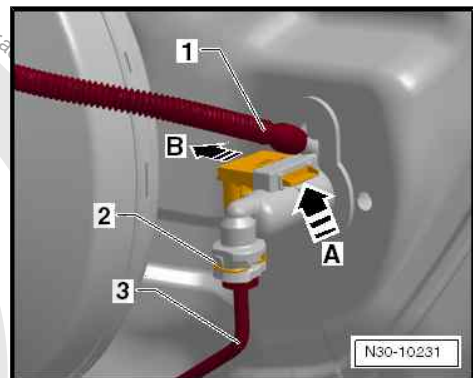



30 – Clutch

1 Clutch operation

- ⇒ [“1.1 Overview of fitting locations – clutch mechanism”, page 13](#)
- ⇒ [“1.2 Assembly overview - pedal cluster”, page 16](#)
- ⇒ [“1.3 Assembly overview - clutch hydraulics”, page 20](#)
- ⇒ [“1.4 Assembly overview - clutch release mechanism”, page 24](#)
- ⇒ [“1.5 Removing and installing bearing bush”, page 25](#)
- ⇒ [“1.6 Removing and installing clutch pedal”, page 26](#)
- ⇒ [“1.7 Removing and installing over-centre spring”, page 28](#)
- ⇒ [“1.8 Removing and installing extension spring”, page 30](#)
- ⇒ [“1.9 Removing and installing mounting bracket”, page 31](#)
- ⇒ [“1.10 Removing and installing clutch master cylinder”, page 39](#)
- ⇒ [“1.11 Removing and installing clutch slave cylinder”, page 41](#)
- ⇒ [“1.12 Removing and installing lines for clutch mechanism”, page 43](#)
- ⇒ [“1.13 Bleeding clutch mechanism”, page 46](#)
- ⇒ [“1.14 Removing and installing clutch pedal switch F36 ”, page 47](#)
- ⇒ [“1.15 Checking clutch master cylinder and clutch slave cylinder”, page 48](#)
- ⇒ [“1.16 Removing and installing clutch position sender G476 ”, page 48](#)
- ⇒ [“1.17 Repairing clutch release mechanism”, page 51](#)

1.1 Overview of fitting locations – clutch mechanism

- ⇒ [“1.1.1 Overview of fitting locations – clutch mechanism, up!”, page 13](#)
- ⇒ [“1.1.2 Overview of fitting locations – clutch mechanism, Polo”, page 15](#)

1.1.1 Overview of fitting locations – clutch mechanism, up!

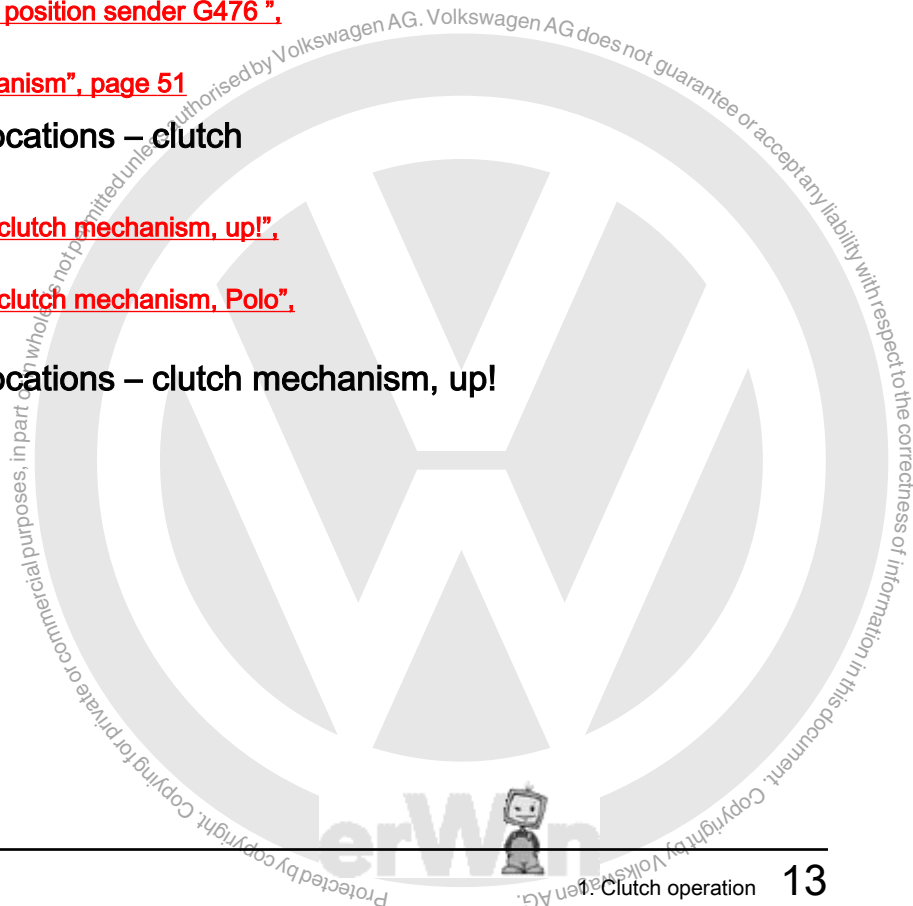



I -
⇒ ["1.2.1 Assembly overview - pedal cluster, up!"](#), page 16

II -
⇒ ["1.3 Assembly overview - clutch hydraulics"](#), page 20

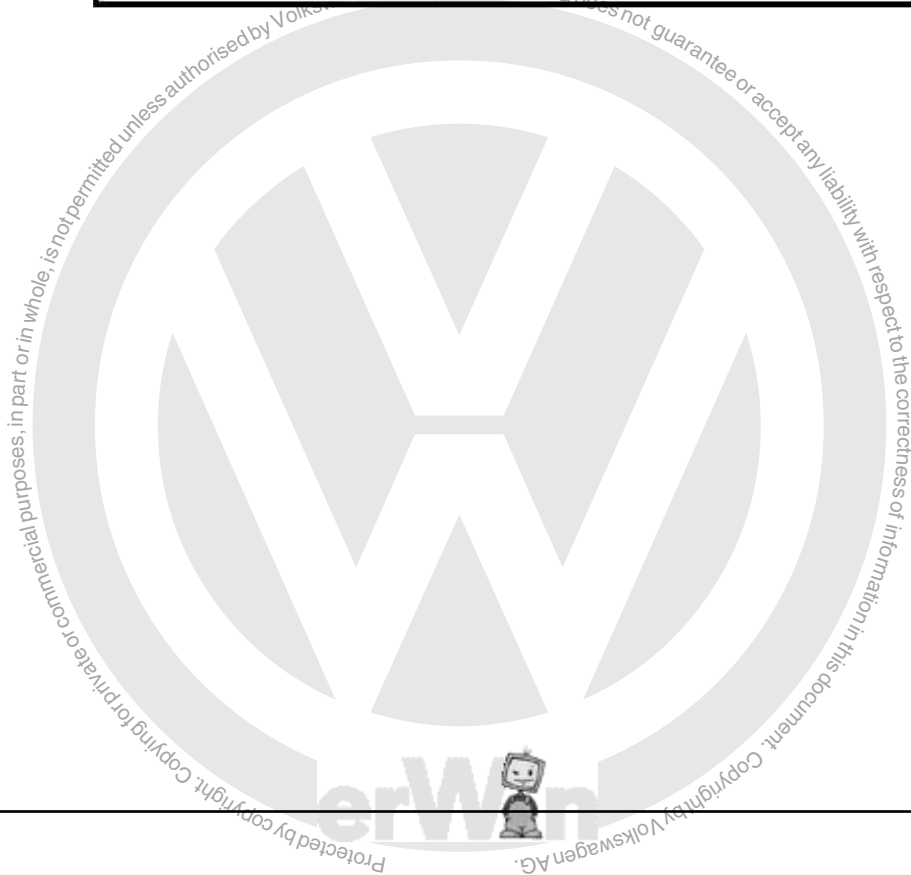
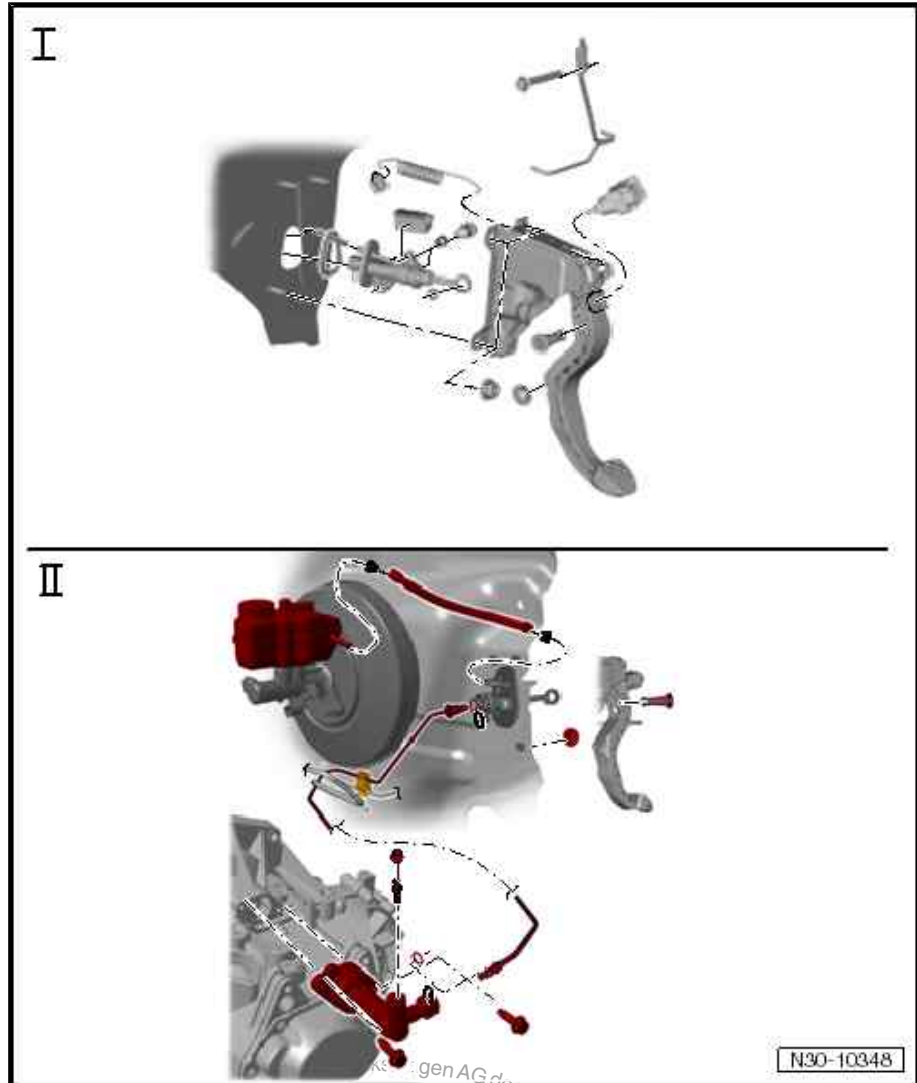



1.1.2 Overview of fitting locations – clutch mechanism, Polo

I -
⇒ [“1.2.2 Assembly overview – pedal cluster, Polo”, page 18](#)

II -
⇒ [“1.3.2 Assembly overview – clutch hydraulics, Polo, LHD vehicles”, page 22](#)

III -
⇒ [“1.3.3 Assembly overview – clutch hydraulics, Polo, RHD vehicles”, page 23](#)

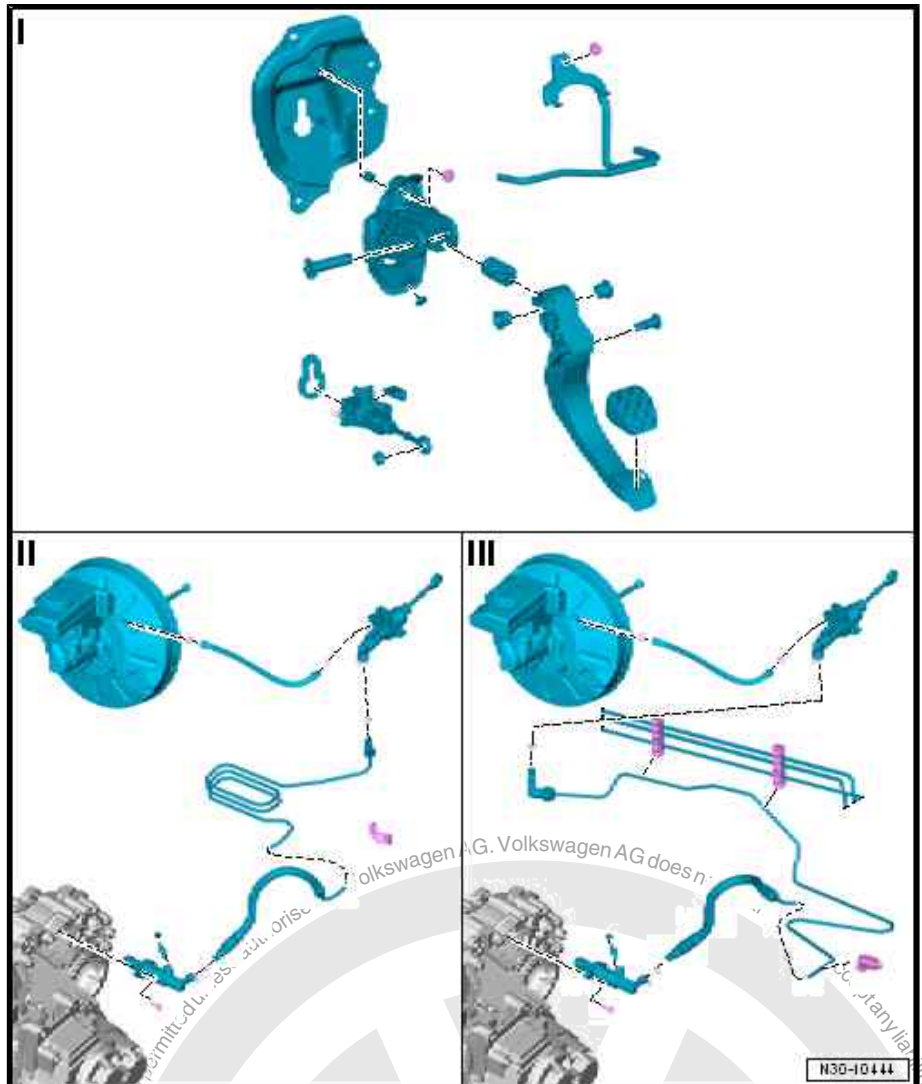



1.2 Assembly overview - pedal cluster

⇒ ["1.2.1 Assembly overview – pedal cluster, up!", page 16](#)

⇒ ["1.2.2 Assembly overview – pedal cluster, Polo", page 18](#)

1.2.1 Assembly overview – pedal cluster, up!

1 - Bulkhead

- With support for mounting bracket and clutch master cylinder.

2 - Seal

- Self-adhesive
- Renew after removing mounting bracket or clutch master cylinder
- Stick to clutch master cylinder.

3 - Supply hose

- Renewing ⇒ [page 20](#)

4 - Support

- fit into mounting bracket ⇒ [page 31](#) Installing extension spring
- No specific installation position needs to be adhered to.

5 - Clutch position sender - G476-

- Installed depending on version.
- Can be checked using ⇒ Vehicle diagnostic tester in [Guided Fault Finding](#) mode
- Allocation ⇒ Electronic parts catalogue (ETKA)
- Removing and installing ⇒ [page 48](#)

6 - Spring

- Hooked into mounting bracket and into clutch pedal
- Removing and installing ⇒ [page 30](#)

7 - Bush

- Qty. 2
- Chamfer -arrow- faces clutch master cylinder.
- Press in flush.

8 - Bolt

- 13 Nm

9 - Mounting bracket with clutch pedal

- Removing and installing ⇒ [page 31](#)

10 - Bolt

- LHD vehicles
- For crash bar on steering column

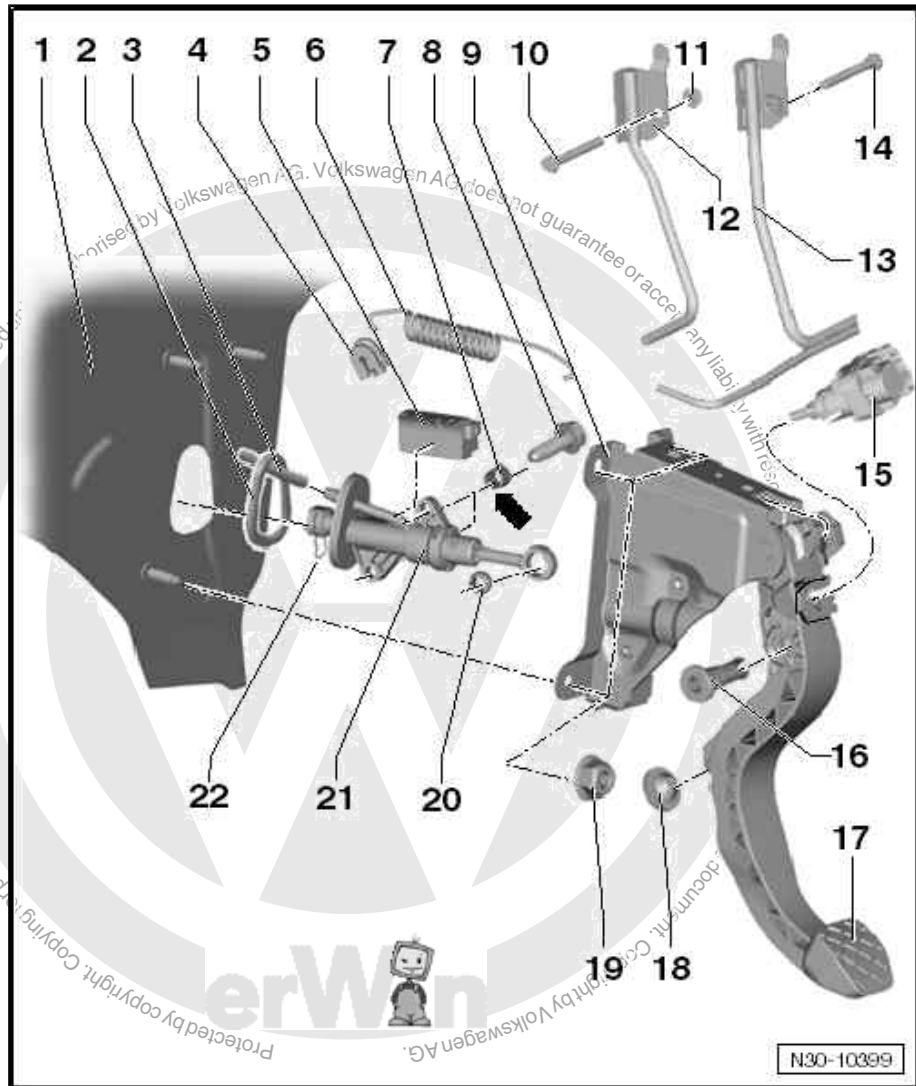



- 20 Nm

11 - Hexagon nut

- LHD vehicles
- For crash bar on steering column

12 - Crash bar

- LHD vehicles
- Attached to steering column
- Allocate components using ⇒ Electronic parts catalogue (ETKA)

13 - Crash bar

- RHD vehicles
- Attached to steering column
- Allocate components using ⇒ Electronic parts catalogue (ETKA)

14 - Bolt

- RHD vehicles
- For crash bar on steering column
- 20 Nm

15 - Clutch pedal switch - F36-

- Installed depending on version.
- Allocate components using ⇒ Electronic parts catalogue (ETKA)
- Removing and installing ⇒ [page 47](#)

16 - Bearing mounting

- For plunger/clutch master cylinder
- Renew after removal

17 - Cap

18 - Buffer stop

- For clutch pedal

19 - Hexagon nut

- Qty. 3
- Self-locking
- Renew after removal
- 25 Nm

20 - Bearing bush

- Removing and installing ⇒ [page 25](#)

21 - Clutch master cylinder

- Removing and installing ⇒ [page 39](#)

22 - Clip

- To remove pipe/hose line, pull out clip to stop
- Can be pressed in as far as stop before fitting line



1.2.2 Assembly overview – pedal cluster, Polo

1 - Clutch pedal

- Removing and installing
⇒ [page 26](#)

- Do not grease

2 - Bearing bush

- Removing and installing
⇒ [page 26](#)

- Do not grease

3 - Clutch master cylinder

- Removing and installing
⇒ [page 40](#)

4 - Clip

- To remove pipe/hose line, pull out clip to stop
- Can be pressed in as far as stop before fitting line

5 - Seal

- Self-adhesive
- Renew after removing mounting bracket or clutch master cylinder
- Glue onto clutch master cylinder

6 - Clutch position sender - G476-

- Can be checked using
⇒ Vehicle diagnostic tester in Guided Fault Finding mode
- Allocation ⇒ Electronic parts catalogue (ETKA)
- Removing and installing
⇒ [page 49](#)

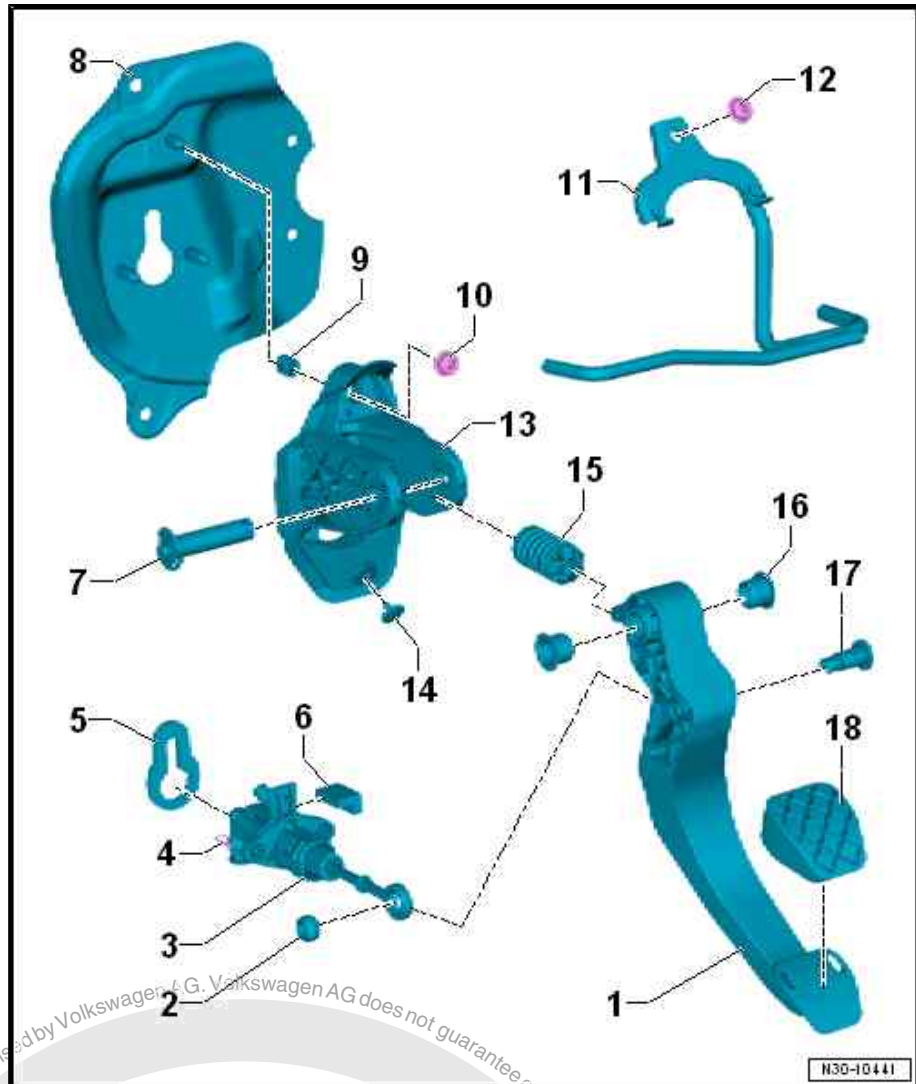

7 - Pivot pin

- Renew after removal
- Do not grease

8 - Bulkhead

- With studs for securing mounting bracket and master cylinder

9 - Bush

- For upper mounting hole in mounting bracket
- Bushes for lower mounting holes in mounting bracket are located in master cylinder

10 - Hexagon nut

- For securing mounting bracket and clutch master cylinder to plenum chamber bulkhead
- Qty. 3
- Self-locking
- Renew after removal
- 25 Nm

11 - Crash bar

- Secured to module carrier



- Allocate according to ⇒ Electronic parts catalogue (ETKA)

12 - Hexagon nut

- For crash bar on module carrier
- Renew after removal
- 20 Nm

13 - Mounting bracket

- For clutch pedal
- Removing and installing ⇒ [page 35](#)
- Using drift - VW 207- drive bushes for the studs used to fasten the mounting bracket onto the bulkhead, into the holes in the mounting bracket

14 - Buffer stop

15 - Over-centre spring or extension spring

- Grease support on mounting bracket
- For grease allocation, refer to ⇒ Electronic parts catalogue (ETKA)
- Installed depending on version.
- Different versions exist; for correct version refer to ⇒ Electronic parts catalogue (ETKA)
- Removing and installing over-centre spring ⇒ [page 28](#)
- Removal and installation of extension spring are identical to removal and installation of over-centre spring ⇒ [page 28](#)

16 - Bearing bush

- Do not grease

17 - Bearing mounting

- For plunger/clutch master cylinder
- Renew after removal
- Do not grease

18 - Cap



1.3 Assembly overview - clutch hydraulics

⇒ [“1.3.1 Assembly overview – clutch hydraulics, up!”](#), page 20

⇒ [“1.3.2 Assembly overview – clutch hydraulics, Polo, LHD vehicles”](#), page 22

⇒ [“1.3.3 Assembly overview – clutch hydraulics, Polo, RHD vehicles”](#), page 23

1.3.1 Assembly overview – clutch hydraulics, up!

1 - Brake fluid reservoir

2 - Supply hose

3 - Seal

- If damaged, renew together with supply hose
- The seals must be located in supply hose

4 - Clutch master cylinder

- Removing and installing ⇒ [page 39](#)

5 - Clip

- To remove pipe/hose line, pull out clip to stop
- Can be pressed in as far as stop before fitting line

6 - Mounting bracket with clutch pedal

7 - Bearing mounting

- For plunger/clutch master cylinder

8 - Hexagon nut

- ⇒ [page 16](#)

9 - Seal / O-ring

- Renew if damaged
- Pull onto line connection
- Insert with brake fluid
- Seals/O-rings are adapted to material of line connection ⇒ [page 43](#)
- Allocation ⇒ Electronic parts catalogue (ETKA)

10 - Pipe

- Installed on left-hand drive vehicles as an alternative to pipe/hose line.
- Different lengths for LHD and RHD vehicles.
- Allocation ⇒ Electronic parts catalogue (ETKA)

11 - Pipe/hose line

12 - Bracket

- Only LHD.
- Secured to body
- For brake lines, pipe line and pipe/hose line.
- Identifying differences between brackets for pipe line and pipe/hose line ⇒ [page 21](#) .

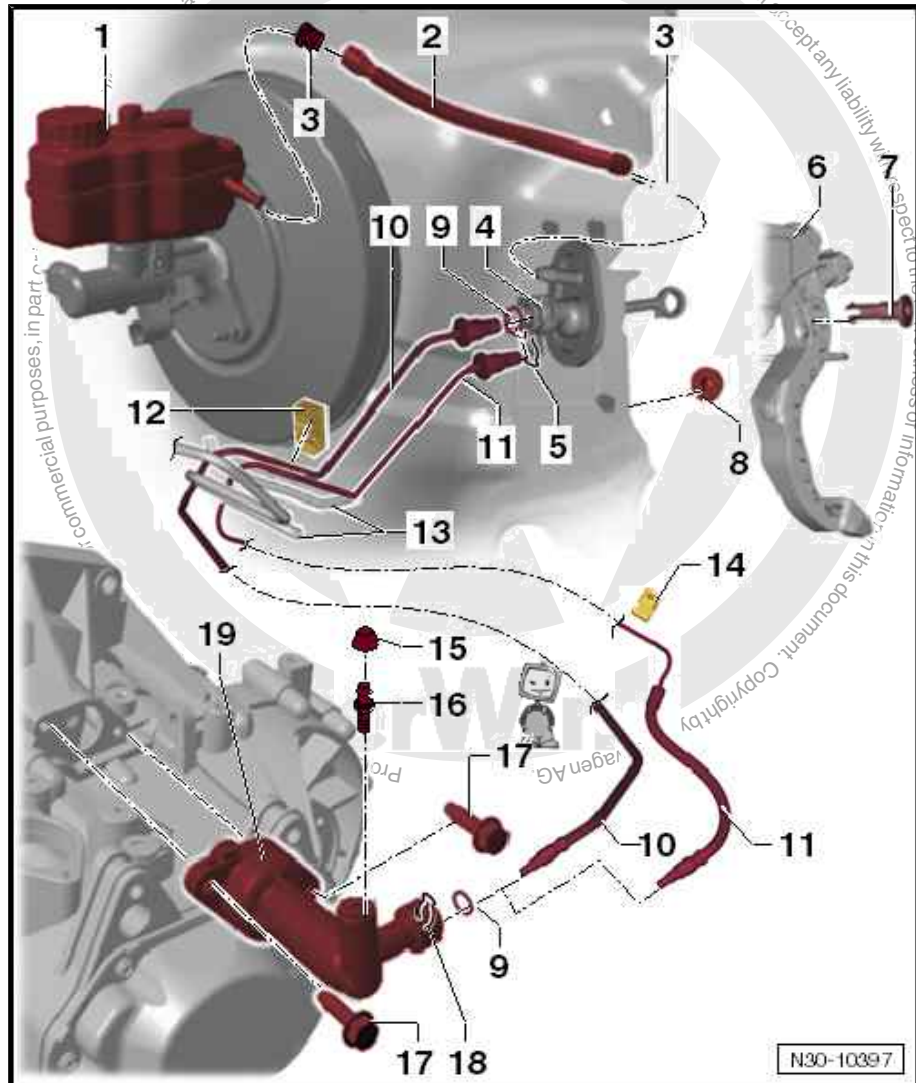



13 - Brake lines

- Various number
- Allocation ⇒ Electronic parts catalogue (ETKA)

14 - Bracket

- Only RHD.
- Secured to body

15 - Dust cap

16 - Bleeder valve

- Bleeding clutch mechanism ⇒ [page 46](#)
- Specified torque ⇒ [page 46](#)

17 - Hexagon bolt

- ⇒ [page 24](#)

18 - Clip

- To remove pipe/hose line, pull out clip to stop
- Can be pressed in as far as stop before fitting line

19 - Clutch slave cylinder

- Allocation ⇒ Electronic parts catalogue (ETKA)
- Removing and installing ⇒ [page 41](#)

LHD, identifying differences between brackets for pipe line and pipe/hose line

Dimension "a" mm	Line configuration
approx. 6	Pipe
approx. 8	Pipe/hose line

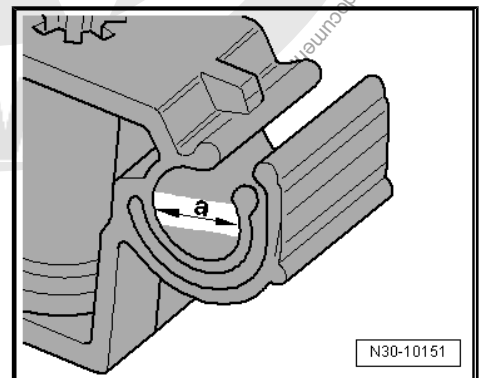



1.3.2 Assembly overview – clutch hydraulics, Polo, LHD vehicles

1 - Hexagon bolt

- Specified torque
⇒ [page 24](#)

2 - Bleeder valve

- Specified torque
⇒ [page 46](#)
- Bleeding clutch mechanism ⇒ [page 46](#)

3 - Dust cap

4 - Supply hose

5 - Brake fluid reservoir

6 - Seals

- Must be fitted in supply hose
- If damaged, renew together with supply hose

7 - Clutch master cylinder

- Removing and installing
⇒ [page 40](#)

8 - Clip

- To remove pipe/hose line, pull out clip to stop
- Can be pressed in as far as stop before fitting line

9 - Seal / O-ring

- Renew if damaged
- Pull onto line connection
- Insert with brake fluid
- Seals/O-rings are adapted to configuration of line connection
⇒ [page 43](#)
- Allocation ⇒ Electronic parts catalogue (ETKA)

10 - Pipe/hose line

- Actual number of windings may vary from that shown in illustration
- Allocation ⇒ Electronic parts catalogue (ETKA)
- Removing and installing ⇒ [page 43](#)

11 - Bracket

- For pipe/hose line

12 - Seal / O-ring

- Renew if damaged
- Pull onto line connection
- Insert with brake fluid
- Seals/O-rings are adapted to configuration of line connection ⇒ [page 43](#)
- Allocation ⇒ Electronic parts catalogue (ETKA)

13 - Clip

- To remove pipe/hose line, pull out clip to stop
- Can be pressed in as far as stop before fitting line

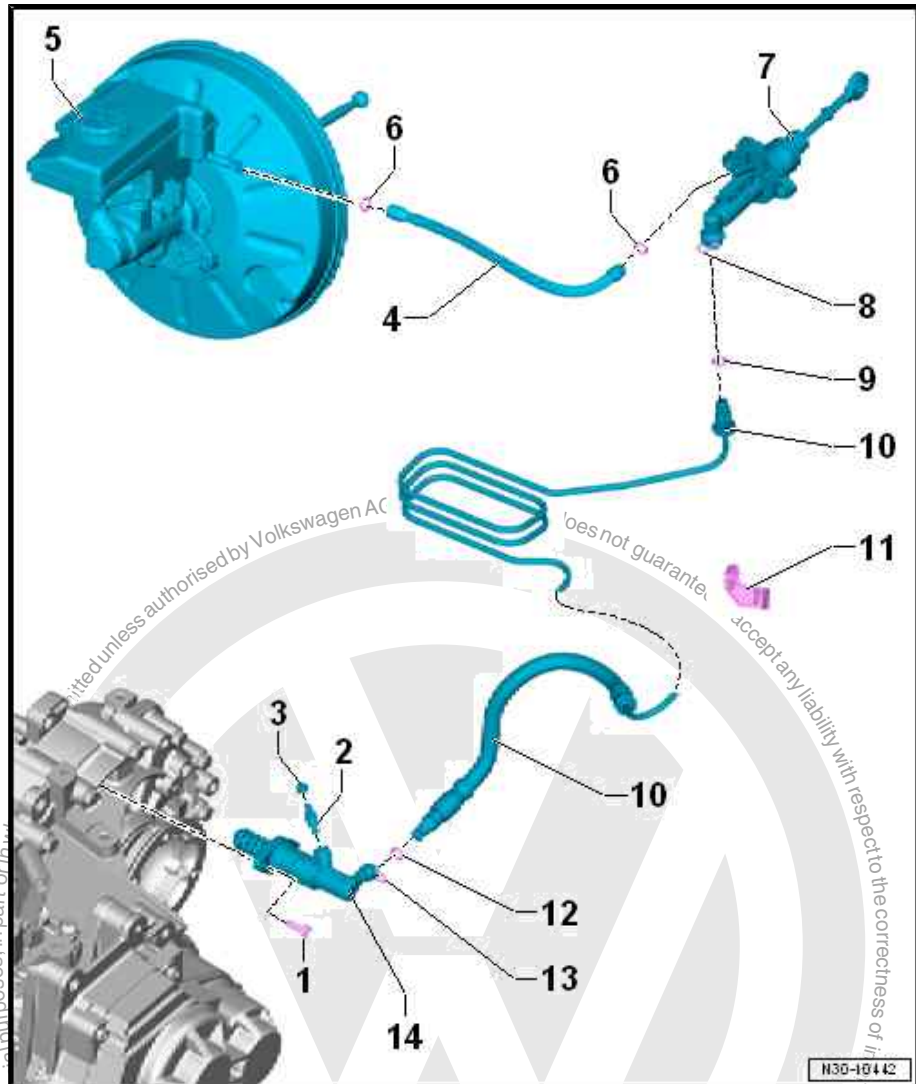



14 - Clutch slave cylinder

- Removing and installing ⇒ [page 41](#)

1.3.3 Assembly overview – clutch hydraulics, Polo, RHD vehicles

1 - Hexagon bolt

- Specified torque
 ⇒ [page 24](#)

2 - Clutch slave cylinder

- Removing and installing
 ⇒ [page 41](#)

3 - Gearbox

4 - Seal / O-ring

- Renew if damaged
- Pull onto line connection
- Insert with brake fluid
- Seals/O-rings are adapted to configuration of line connection
 ⇒ [page 43](#)
- Allocation ⇒ Electronic parts catalogue (ETKA)

5 - Brake fluid reservoir

6 - Seals

- Must be fitted in supply hose
- If damaged, renew together with supply hose

7 - Supply hose

8 - Clutch master cylinder

- Removing and installing
 ⇒ [page 40](#)

9 - Clip

- To remove pipe/hose line, pull out clip to stop
- Can be pressed in as far as stop before fitting line

10 - Bracket

- Secured to body
- For brake lines and pipe/hose assembly

11 - Brake lines

12 - Bracket

- For pipe/hose line

13 - Pipe/hose line

- Allocation ⇒ Electronic parts catalogue (ETKA)
- Removing and installing ⇒ [page 43](#)

14 - Seal / O-ring

- Renew if damaged
- Pull onto line connection

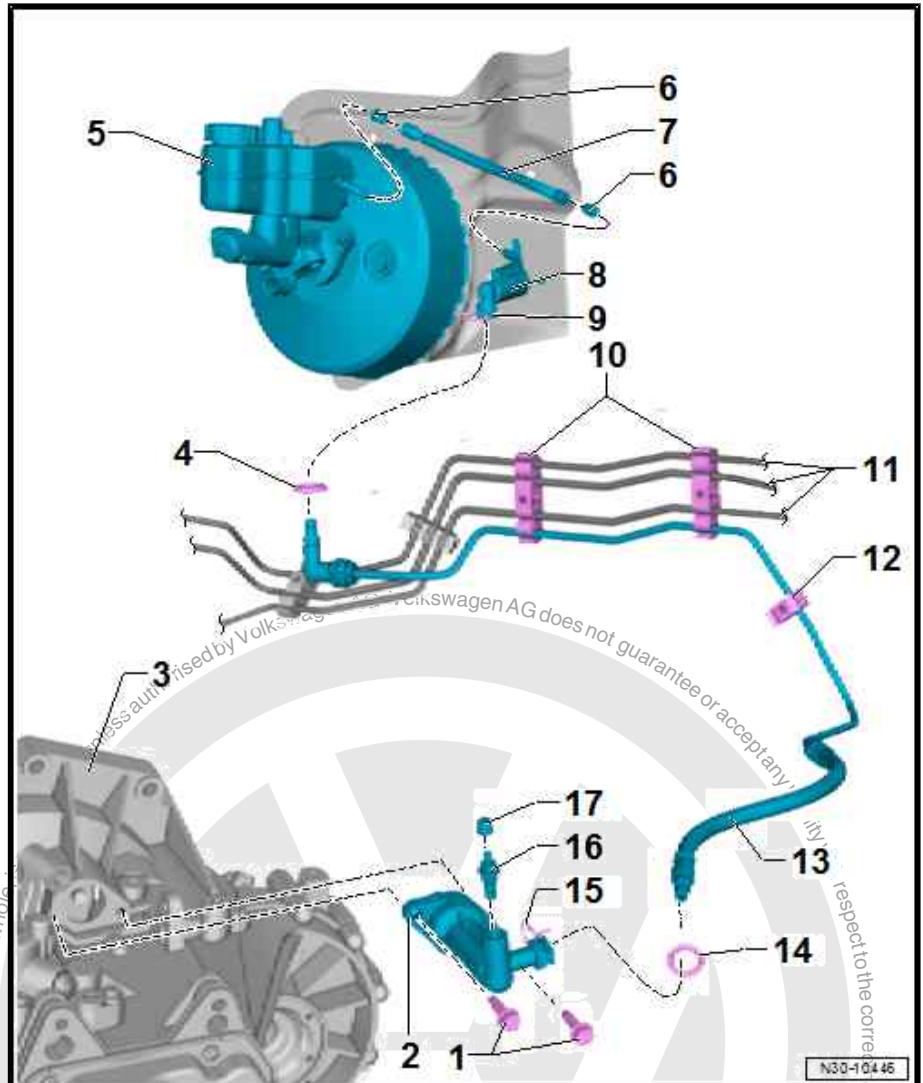



- Insert with brake fluid
- Seals/O-rings are adapted to configuration of line connection ⇒ [page 43](#)
- Allocation ⇒ Electronic parts catalogue (ETKA)

15 - Clip

- To remove pipe/hose line, pull out clip to stop
- Can be pressed in as far as stop before fitting line

16 - Bleeder valve

- Bleeding clutch mechanism ⇒ [page 46](#)
- Specified torque ⇒ [page 22](#)

17 - Dust cap

1.4 Assembly overview - clutch release mechanism

1 - Release bearing

- To remove and install, remove gearbox
- Remove and install together with clutch release lever and guide sleeve ⇒ [page 51](#) to ⇒ [page 52](#)
- Do not wash out bearing; wipe only
- Renew noisy bearings

2 - Bolt

- Renew after removal
- 5 Nm and turn 90° further

3 - Clutch release lever

- To remove and install, remove gearbox
- Remove and install together with clutch release bearing and guide sleeve ⇒ [page 51](#) .
- Remove old grease
- Grease contact surface of ball-head pin with grease for clutch plate splines .
- Allocate grease using ⇒ Electronic parts catalogue (ETKA) .

4 - Retaining spring

- To remove and install, remove gearbox
- Secure to clutch release lever

5 - Guide bush

- To remove and install, remove gearbox
- Remove and install together with release bearing and clutch release lever ⇒ [page 51](#) to ⇒ [page 51](#)

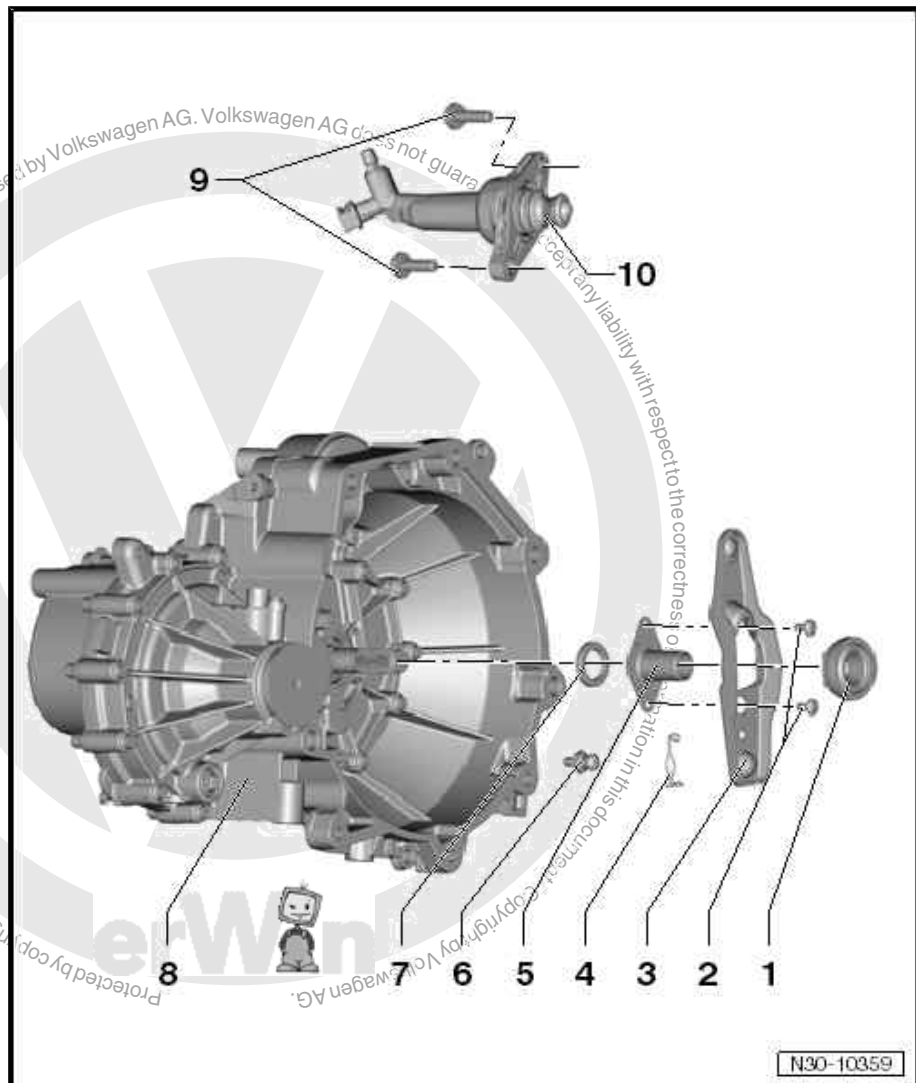



6 - Ball-head pin

- To remove and install, remove gearbox
- Remove old grease
- Grease contact surface of ball-head pin with grease for clutch plate splines .
- Allocate grease using ⇒ Electronic parts catalogue (ETKA)
- 20 Nm

7 - Input shaft seal

- Renew after removal ⇒ [page 149](#)

8 - Gearbox

9 - Hexagon bolt

- 20 Nm

10 - Clutch slave cylinder

- Removing and installing ⇒ [page 41](#)

1.5 Removing and installing bearing bush

Removing

Disconnect battery ⇒ Electrical system; Rep. gr. 27 ; Battery; Disconnecting and connecting battery

Polo

- Remove over-centre spring/extension spring ⇒ [page 28](#) .
- Compress catches -arrows- and take out pin -1- towards right side.
- Pull clutch pedal into passenger compartment as far as stop.

up!

- Compress fasteners on pivot pin for plunger of master cylinder on clutch pedal. Pull off pin towards left.
- Observe extension spring ⇒ [page 16](#) .
- Pull clutch pedal into passenger compartment as far as stop. If necessary, remove clutch pedal switch - F36- to do so ⇒ [page 47](#) .

Continuation for all

- Turn plunger of clutch master cylinder so that recesses -1- or marking -2- become visible.
- Ensure that recesses -1- and marking -2- point in same direction.
- Remove bearing bush -A- from recesses -1-.

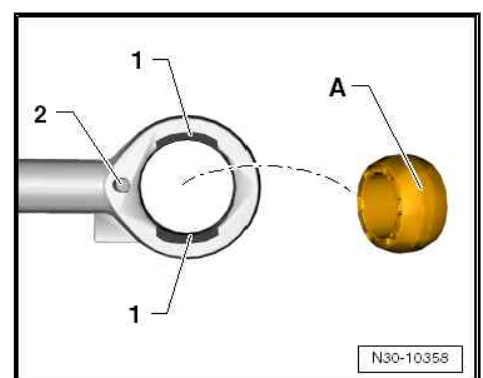
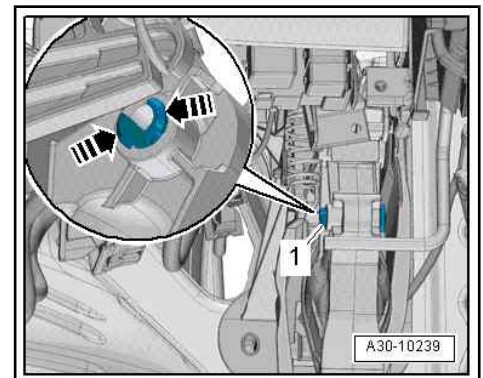



Installing

- Turn plunger of clutch master cylinder so that recesses -1- or marking -2- become visible.

Ensure that recesses -1- and marking -2- point in same direction.

- Fit and swivel bearing bush -A- into recesses -1-.

Polo

- Install over-centre spring/extension spring ⇒ [page 28](#) .

Continuation for all

- Connect plunger/clutch master cylinder to clutch pedal.
- Use new pivot pin.

up!

- Observe extension spring ⇒ [page 16](#) .
- Install clutch pedal switch - F36- if necessary ⇒ [page 47](#) .

Continuation for all

- Connect battery ⇒ Electrical system; Rep. gr. 27 ; Battery; Disconnecting and connecting battery .

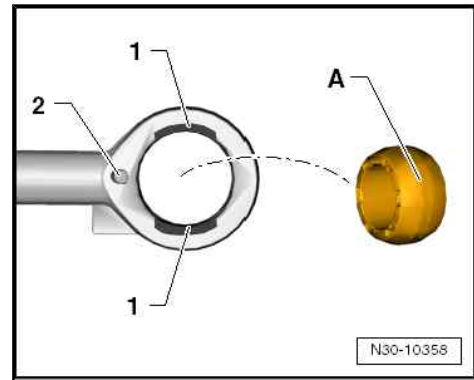

1.6 Removing and installing clutch pedal

⇒ [“1.6.1 Removing and installing clutch pedal, up!”](#), [page 26](#)

⇒ [“1.6.2 Removing and installing clutch pedal, Polo, LHD vehicles”](#), [page 26](#)

⇒ [“1.6.3 Removing and installing clutch pedal, Polo, RHD vehicles”](#), [page 27](#)

1.6.1 Removing and installing clutch pedal, up!

The clutch pedal is removed and installed together with the mounting bracket ⇒ [page 31](#) .

The clutch pedal stays fitted to the mounting bracket.

1.6.2 Removing and installing clutch pedal, Polo, LHD vehicles

Removing

- Move driver seat as far back as possible.
- Move steering wheel to uppermost position using the entire range of adjustment of the steering column.
- Remove over-centre spring/extension spring ⇒ [page 28](#) .
- If installed in area of mounting bracket: remove onboard supply control unit - J519- (do not disconnect connector) ⇒ Electrical system; Rep. gr. 97 ; Control units; Removing and installing onboard supply control unit - J519- .



Removing bearing shaft for clutch pedal:

- Break off both locking devices -A- using a screwdriver -1-.

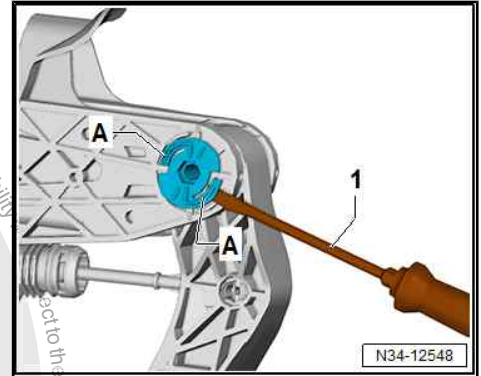

-1- = 10 mm hexagon bit

- Turn bearing shaft for clutch pedal to left -arrow- as far as stop.
- Move clutch pedal slightly so that the pivot pin can be pulled out.

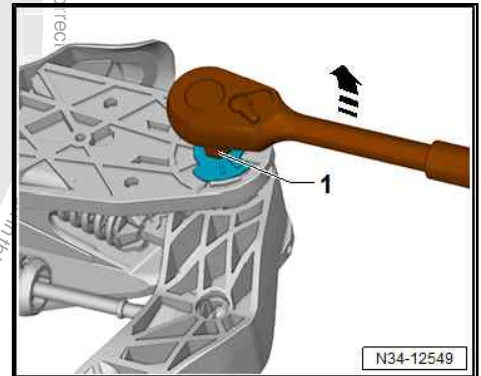

Installing

Install in reverse order of removal, observing the following:

- 1- = 10 mm hexagon bit
- Renew pivot pin after removing.
- Depress clutch pedal slightly and push new pivot pin through to stop.
- Turn pivot pin to right to stop, -direction of arrow-.
- Locking devices -A- must audibly engage.
- Install over-centre spring/extension spring ⇒ [page 28](#) .
- If removed beforehand: install onboard supply control unit - J519- ⇒ Electrical system; Rep. gr. 97 ; Control units; Removing and installing onboard supply control unit - J519- .

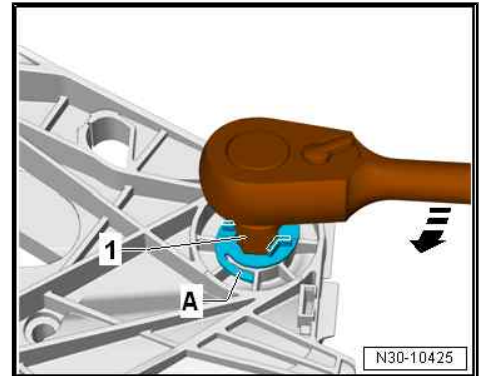

1.6.3 Removing and installing clutch pedal, Polo, RHD vehicles

Removing

- Remove mounting bracket ⇒ [page 35](#) .



- Compress fasteners -arrows-, and pull pivot pin -1- for plunger/ clutch master cylinder off towards right (shown in illustration with mounting bracket installed).
- Pull clutch pedal as far as stop.
- Remove over-centre spring/extension spring.

Remove pivot pin the for the clutch pedal as follows:

- Break off both locking devices -A- using a screwdriver -1-.

-1- = 10 mm hexagon bit

- Turn bearing shaft for clutch pedal to left -arrow- as far as stop.
- Move clutch pedal slightly so that the pivot pin can be pulled out.

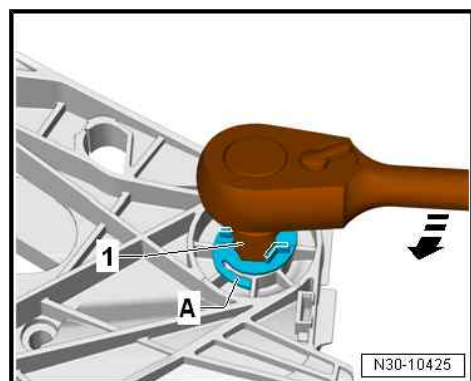
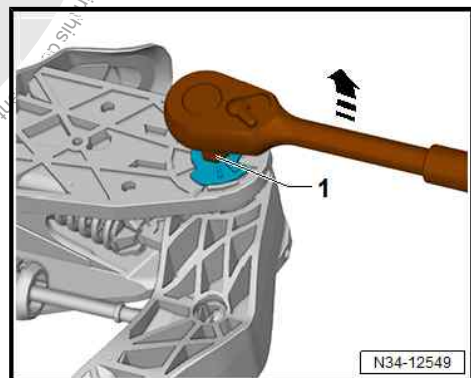
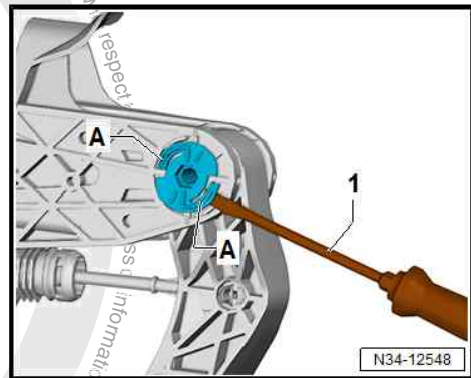
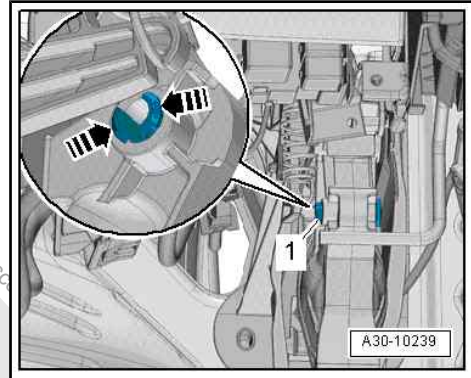

Installing

Install in reverse order of removal, observing the following:

- 1- = 10 mm hexagon bit
- Renew pivot pin after removing.
- Push new pivot pin through to stop.
- Turn pivot pin to right to stop, -direction of arrow-.
- Locking devices -A- must audibly engage.
- Install over-centre spring/extension spring ⇒ [page 28](#) .
- Install mounting bracket ⇒ [page 35](#) .

1.7 Removing and installing over-centre spring

Removing

- Move driver seat as far back as possible.



- Move steering wheel to uppermost position using the entire range of adjustment of the steering column.
- Disconnect battery ⇒ Electrical system; Rep. gr. 27 ; Battery; Disconnecting and connecting battery .
- Compress catches -arrows- and pull out pivot pin -1- for plunger/clutch master cylinder towards right side.
- Pull clutch pedal into passenger compartment as far as stop.
- Remove over-centre spring.

Installing

Install in reverse order of removal, observing the following:

- Receptacle -arrow- for mounting pin of clutch pedal must be vertical.
- Insert over-centre spring from side and from below, adjacent to plunger of master cylinder and adjacent to clutch pedal, into support -A- in mounting bracket.

- Now position over-centre spring on mounting lug of clutch pedal -arrow-.

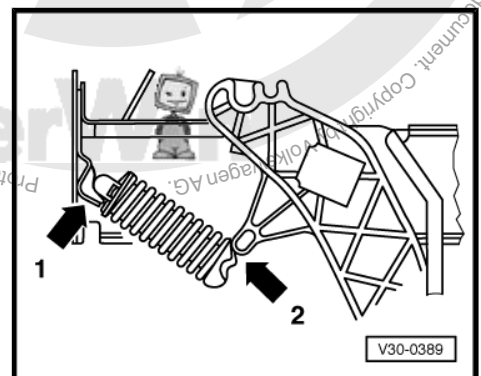
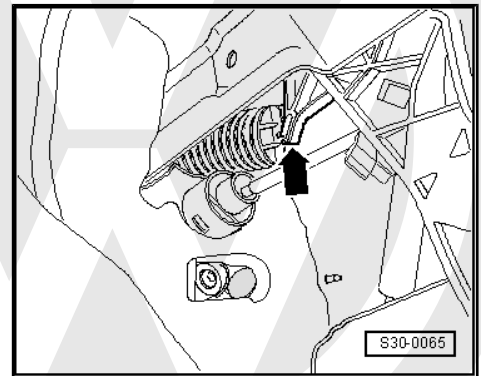
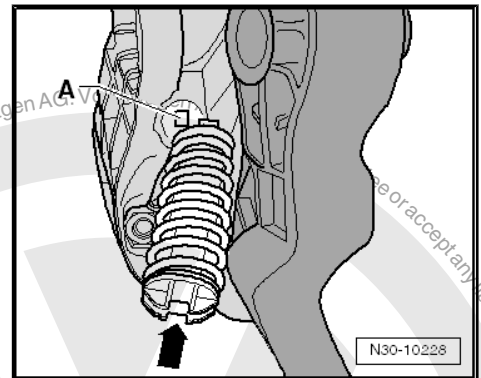
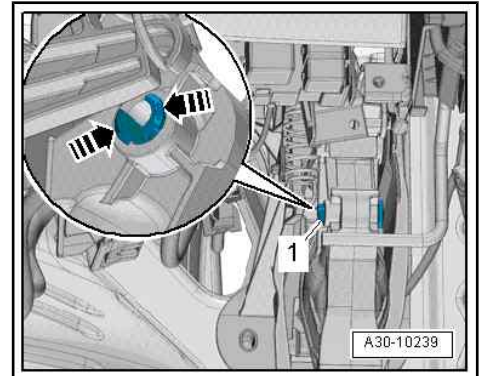

Note

- ◆ *The over-centre spring must be located directly in the mounting -arrow 1- in the bearing bracket to be fitted correctly on the clutch pedal -arrow 2- (⇒ see also previous illustration).*
- ◆ *Otherwise, it will not be possible to install the pivot pin -1- for the plunger/clutch master cylinder (⇒ next illustration).*



- Press clutch pedal in operating position, and push new pivot pin -1- for plunger/clutch master cylinder through to stop.
- Make sure that fasteners -arrows- of pivot pin -1- engage.
- Connect battery => Electrical system; Rep. gr. 27 ; Battery; Disconnecting and connecting battery .

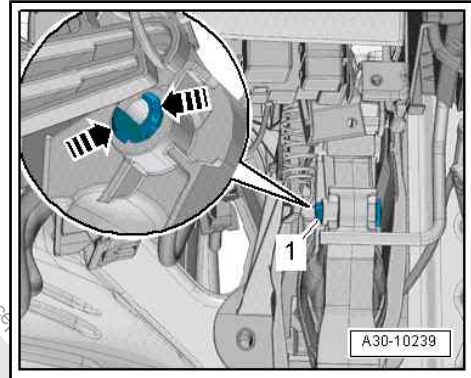

1.8 Removing and installing extension spring

=> ["1.8.1 Removing and installing extension spring, up!"](#), page 30

=> ["1.8.2 Removing and installing extension spring, Polo"](#), page 31

1.8.1 Removing and installing extension spring, up!

Special tools and workshop equipment required

- ◆ Hook - 3438-

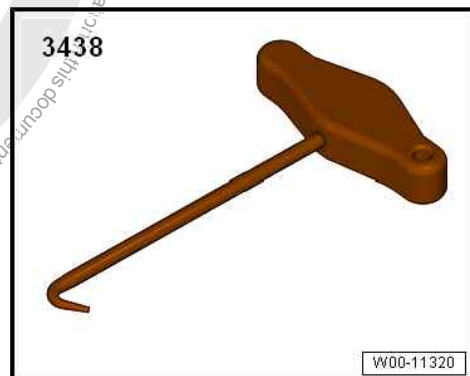

Removing

- Remove mounting bracket => [page 31](#) .
- Carefully clamp mounting bracket in a vice -A-.
- The mounting bracket -arrow 1- is secured in the vice by the edge in the front area.
- The edge ensures that the mounting bracket is not pulled out of the vice when removing the extension spring.
- Pull extension spring firmly out of support and remove.

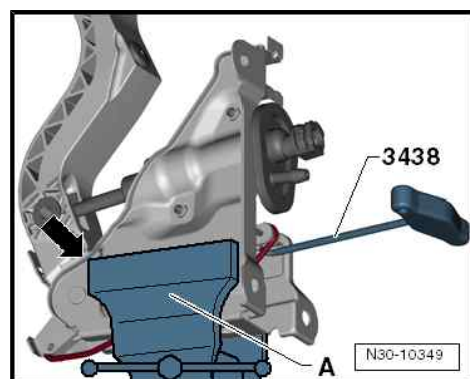



Installing

- Remove mounting bracket ⇒ [page 31](#) .
- Carefully clamp mounting bracket in a vice -A-.
- The mounting bracket -arrow 1- is secured in the vice by the edge in the front area.
- The edge ensures that the mounting bracket is not pulled out of the vice when installing the extension spring.
- Install new support -B- for extension spring.
- Slightly grease following areas for extension spring:
- Mounting -B-
 - Mounting on clutch pedal -arrow 2-
- Grease ⇒ Electronic parts catalogue (ETKA)
- Attach extension spring to support on clutch pedal. -Arrow 2-.
- Attach extension spring to support -B- on mounting bracket.

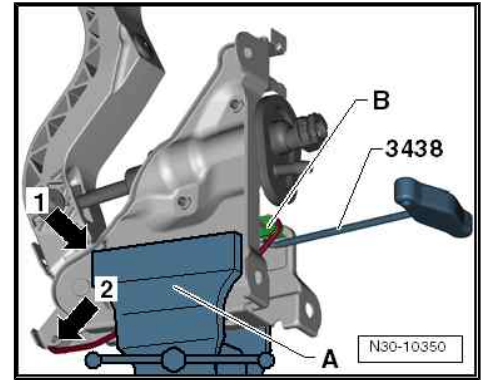

1.8.2 Removing and installing extension spring, Polo

Removal and installation of extension spring are identical to removal and installation of over-centre spring ⇒ [page 28](#)

1.9 Removing and installing mounting bracket

⇒ ["1.9.1 Removing and installing mounting bracket, up!", page 31](#)

⇒ ["1.9.2 Removing and installing mounting bracket, Polo", page 35](#)

1.9.1 Removing and installing mounting bracket, up!



Special tools and workshop equipment required

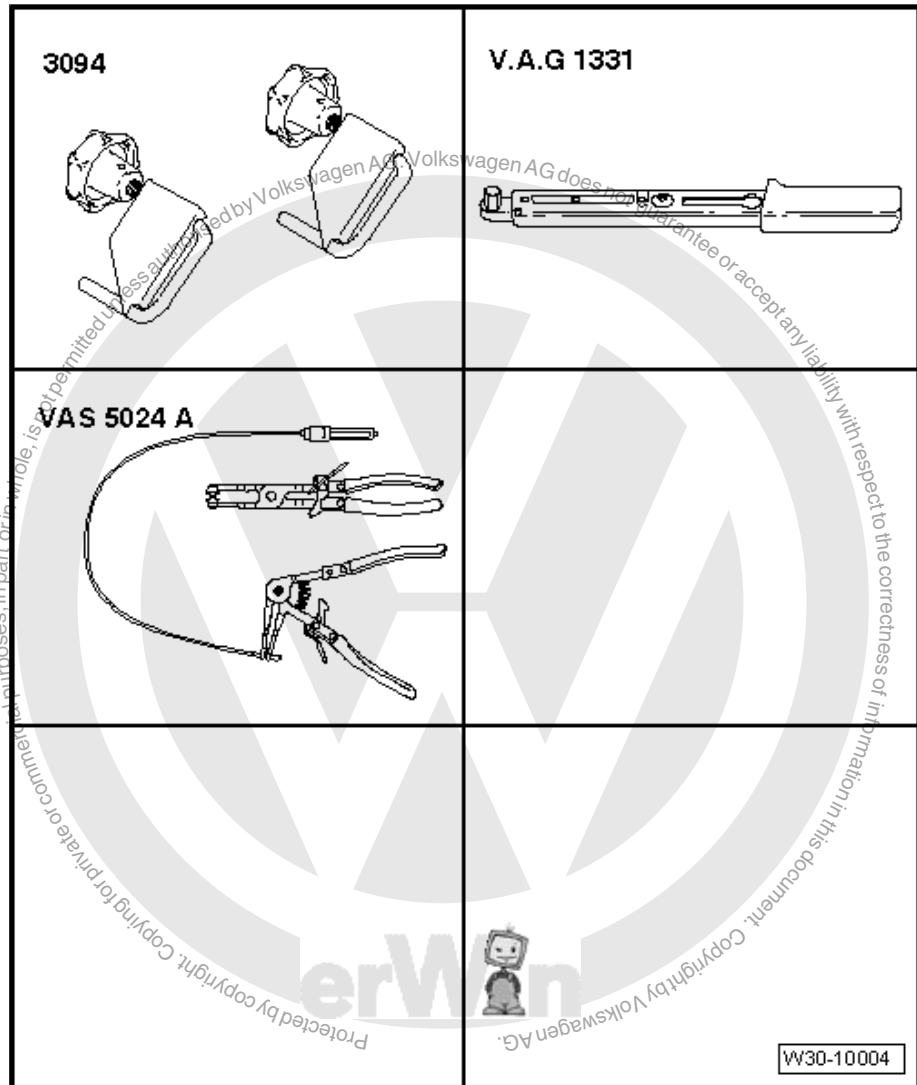

- ◆ Hose clamp - 3094-
- ◆ Torque wrench - V.A.G 1331-
- ◆ Not required, spring-type clip pliers - VAS 5024 A-
- Sealing tool - T10249-

Removing

- Remove battery and battery tray ⇒ Electrical system; Rep. gr. 27 ; Battery; Removing and installing battery .

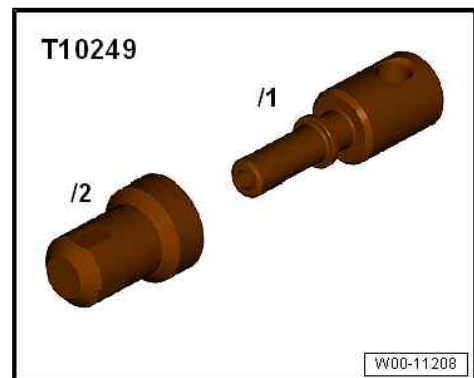



- Clamp off supply hose to clutch master cylinder using hose clamp - 3094 .

⚠ Caution

Risk of leaking brake fluid.

- ◆ *During the following work, ensure that no brake fluid lands on longitudinal member or gearbox. If this does happen, clean the affected areas thoroughly.*
- ◆ *Lay a lint-free cloth under clutch master cylinder.*
- ◆ *When performing work in the footwell, put cloths on the carpet to protect it from possible brake fluid spills.*

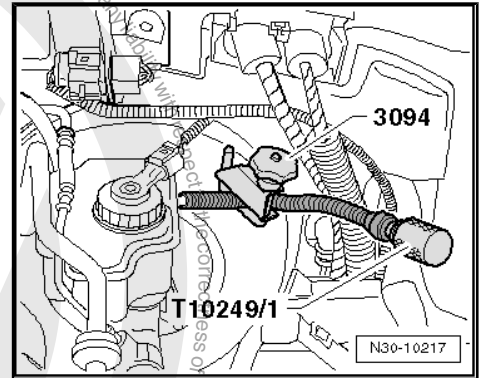

- Disconnect supply hose -1- from clutch master cylinder.
- In addition to clamping off, it can also be sealed with sealing tool - T10249/1- (→ illustration above).
- Release securing clip -2- to stop using screwdriver or a pointed object and disconnect pipe -3- from clutch master cylinder.
- Remove driver side footwell cover ⇒ General body repairs, interior; Rep. gr. 68 ; Compartments/covers; Removing and installing dash panel end trim on driver side .

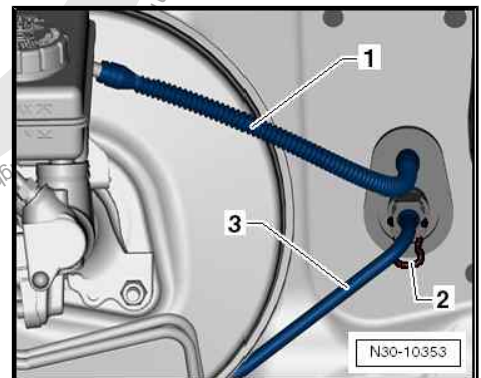

Vehicles with clutch pedal switch - F36- .

- Remove clutch pedal switch - F36- ⇒ [page 47](#) .

LHD vehicles

- Remove crash bar by unscrewing bolt -1-.
- Note nut -2-.

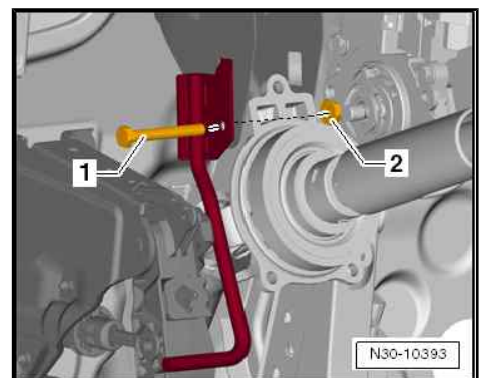

RHD vehicles

- Remove crash bar by unscrewing bolt -1-.

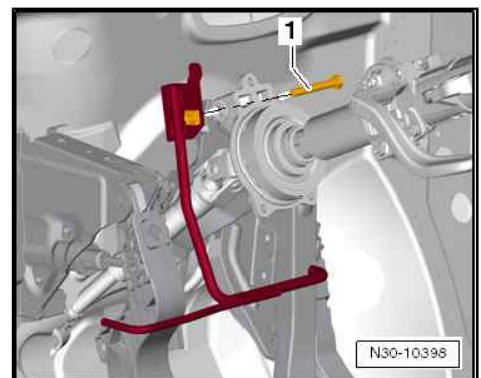



Vehicles with clutch pedal sender - G476- :

- Unclip clutch position sender - G476- from clutch master cylinder -arrow A- and remove from fitting location -arrow B-.
- Remove clutch position sender - G476- with electrical connector connected.

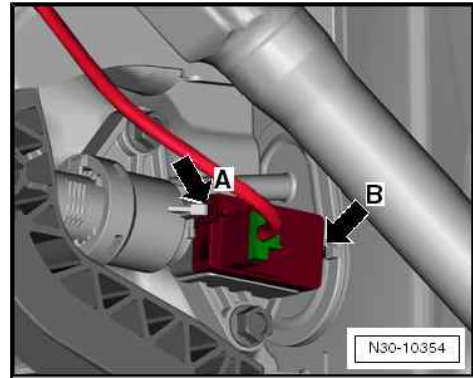

Continuation for all

- Unscrew securing nuts.
- Remove mounting bracket with clutch master cylinder.

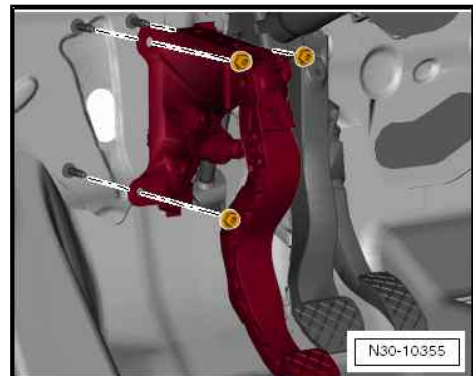

Installing

Install in the reverse order of removal, observing the following.



Note

- ◆ *Renew self-locking nut.*
- ◆ *Renew seal for clutch master cylinder after removing mounting bracket or clutch master cylinder => [Item 2 \(page 16\)](#).*
- Tighten securing nuts for mounting bracket.

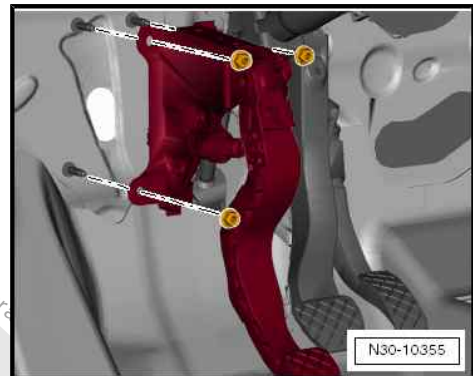

LHD vehicles

- Install crash bar; tighten bolt -1-.

Note nut -2-.

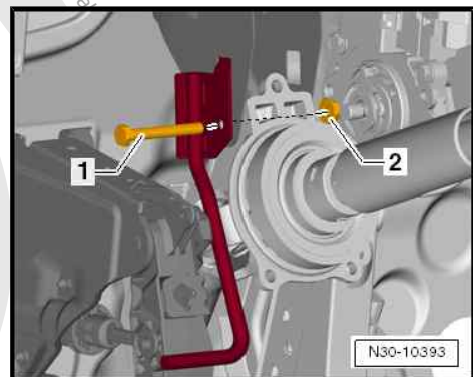



RHD vehicles

- Install crash bar; tighten bolt -1-.

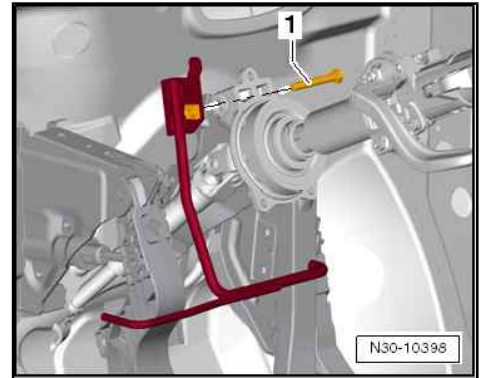

Vehicles with clutch pedal sender - G476- :

- Fit clutch position sender - G476- on clutch master cylinder into fitting location -arrow B- and clip it in -arrow A-.
- Test clutch position sender - G476- by tugging on it.

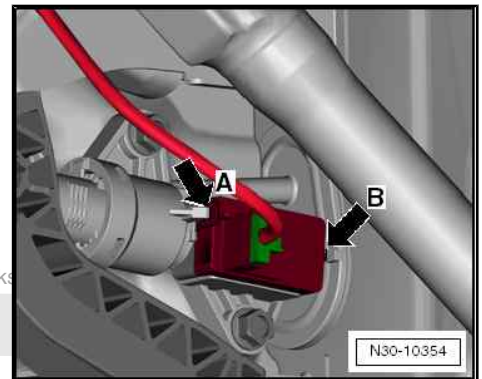

Vehicles with clutch pedal switch - F36- .

- Install clutch pedal switch - F36- => [page 47](#) .

Continuation for all

- Install driver side footwell cover => General body repairs, interior; Rep. gr. 68 ; Compartments/covers; Removing and installing dash panel end trim on driver side .

- After removing hose clamp - 3094- , supply hose -1- must be returned to its original position and shape.
- Press pipe -3- all the way in at master cylinder connection, and press securing clip -2- in all the way.
- Test line by tugging on it.
- Bleed clutch mechanism => [page 46](#) .

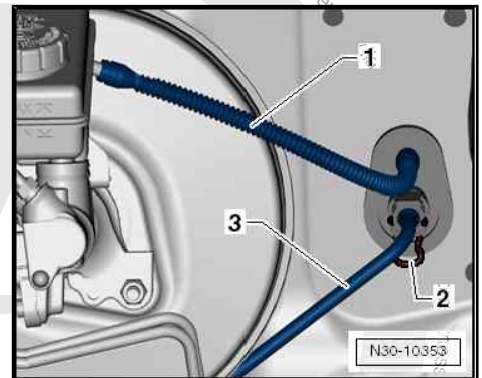

Specified torques

- ◆ For securing mounting bracket to plenum chamber bulkhead => [page 16](#)
- ◆ Crash bar to steering column => [page 16](#)

1.9.2 Removing and installing mounting bracket, Polo

Special tools and workshop equipment required

- ◆ Hose clamps to 25 mm - 3094-

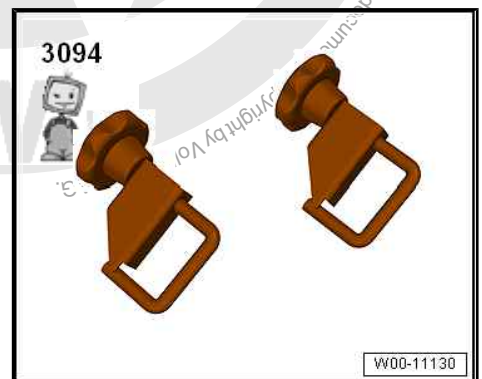



◆ Torque wrench - V.A.G 1331-

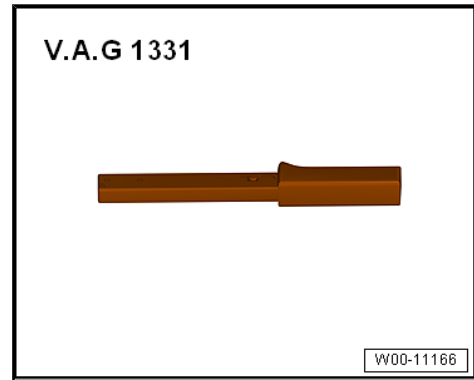

◆ Sealing tool - T10249-

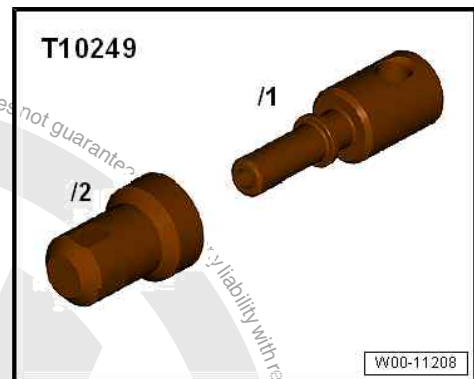

Removing

- Disconnect battery ⇒ Electrical system; Rep. gr. 27 ; Battery; Disconnecting and connecting battery .

LHD vehicles

- Unclip engine control unit from bracket on plenum chamber bulkhead without disconnecting electrical connector, and lay it to one side ⇒ Rep. gr. 24 ; Engine control unit .

RHD vehicles

In some vehicles, master cylinder is located behind a line for air conditioning system -arrow-

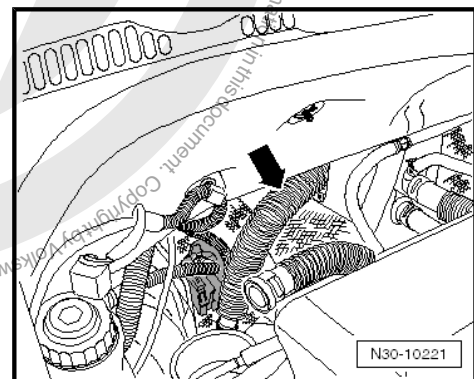



An insulation mat is installed in conjunction with some engines. Appearance may be different from that illustrated.

- Remove insulation mat. Note item -1 to 4-.

Continuation for all

- Remove clutch position sender - G476- (without disconnecting connector) from master cylinder => [page 49](#) .

- Using hose clamp - 3094- , clamp off supply hose -2- to clutch master cylinder.

Note

- ◆ *Clamping off the supply hose with the hose clamp - 3094- will cause a permanent deformation.*
- ◆ *However, this does not damage the supply hose.*
- ◆ *After removing the hose clamp - 3094- , the supply hose must be returned to its original shape.*

Caution

Risk of leaking brake fluid.

- ◆ *During the following work, ensure that no brake fluid lands on longitudinal member or gearbox. If this does happen, clean the affected areas thoroughly.*
- ◆ *Lay a lint-free cloth under clutch master cylinder.*

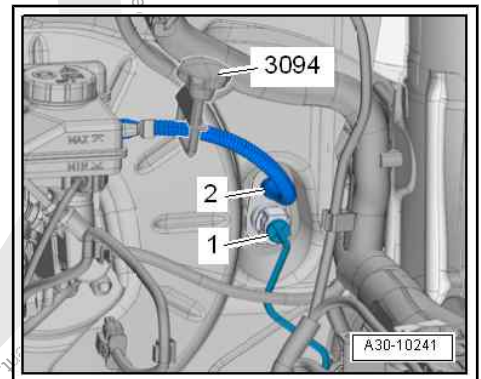
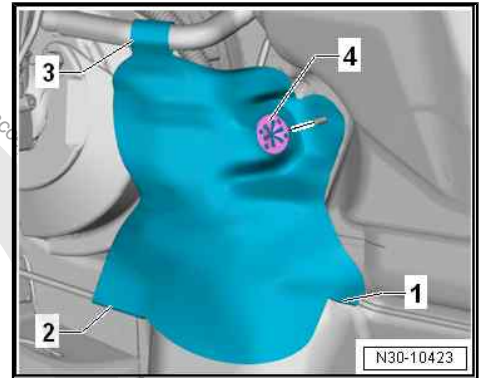

- In addition, for disconnecting, supply hose can be sealed with sealing tool - T10249/1- .
- Pull off supply hose -2- (=> previous illustration).
- Pull clip for pipe/hose assembly -1- all way out (=> previous illustration) and pull off pipe/hose assembly => [page 43](#) .
- Seal openings.

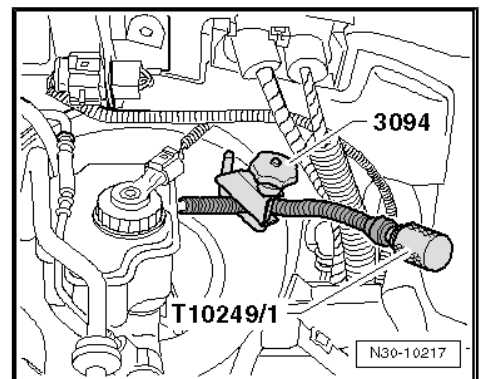



- Unscrew nut -2-, detach crash bar -1-, and push to one side.
- Remove following components if installed in area of mounting bracket:

Onboard supply control unit - J519- (do not disconnect connector)
⇒ Electrical system; Rep. gr. 97 ; Control units; Removing and installing onboard supply control unit - J519-

Footwell vent on driver side ⇒ Heating, air conditioning; Rep. gr. 87 ; Air duct; Assembly overview – air duct and air distribution in passenger compartment

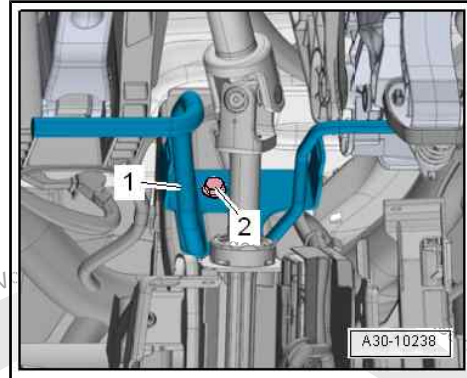

- Unscrew nuts -1- and -2-.
- Remove mounting bracket -3- with clutch master cylinder.

Installing

Install in reverse order of removal, observing the following:

Note

- ◆ Renew self-locking nut.
- ◆ Renew seal for clutch master cylinder after removing mounting bracket or clutch master cylinder ⇒ [Item 5 \(page 18\)](#).

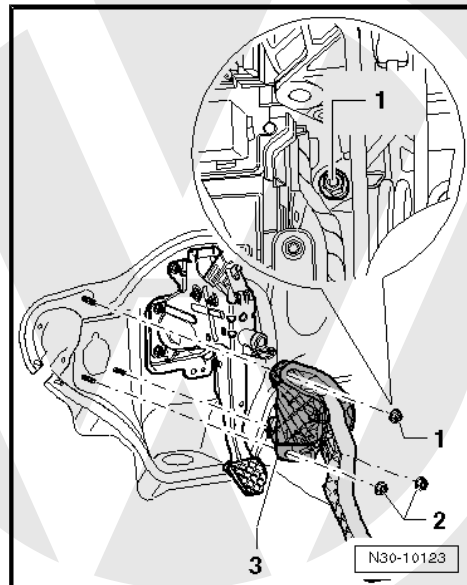

- Fit crash bar -1-, and tighten nut -2-.
- If removed beforehand, reinstall following components:

Onboard supply control unit - J519- ⇒ Electrical system; Rep. gr. 97 ; Control units; Removing and installing onboard supply control unit - J519-

Footwell vent on driver side ⇒ Heating, air conditioning; Rep. gr. 87 ; Air duct; Assembly overview – air duct and air distribution in passenger compartment

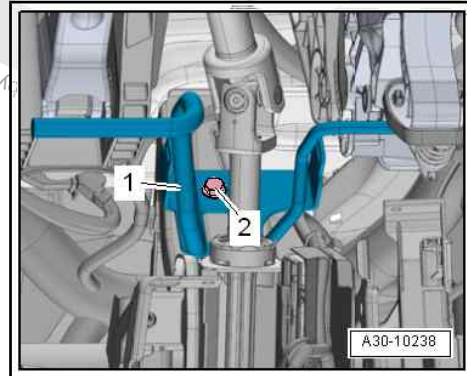

- Insert clutch position sender - G476- into master cylinder with electrical connector connected. Push it in as far as stop ⇒ [page 49](#).

- Connect pipe/hose line -1- to connection ⇒ [page 43](#).
- Connect supply hose -2- at clutch master cylinder.
- After removing the hose clamp - 3094- , the supply hose must be returned to its original shape.

LHD vehicles

- Clip engine control unit with connector connected into bracket on plenum chamber bulkhead ⇒ Rep. gr. 24 ; Engine control unit .

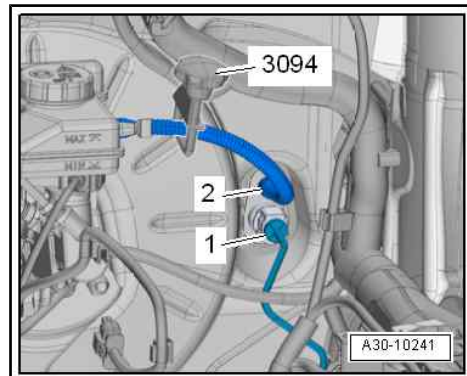



RHD vehicles

- If fitted, fold insulation mat in the sequence -1, 2, 3- around lines.
- Secure insulation mat with lock washer -4-.

Continuation for all

- Bleed clutch mechanism ⇒ [page 46](#) .
- Install and/or connect battery ⇒ Electrical system; Rep. gr. 27 ; Battery; Disconnecting and connecting battery .

Specified torques

- ◆ For securing mounting bracket to plenum chamber bulkhead ⇒ [page 18](#)
- ◆ Crash bar to module carrier ⇒ [page 18](#)

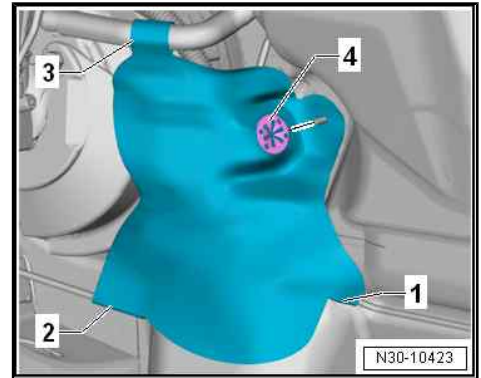

1.10 Removing and installing clutch master cylinder

⇒ [“1.10.1 Removing and installing clutch master cylinder, up!”](#), [page 39](#)

⇒ [“1.10.2 Removing and installing clutch master cylinder, Polo”](#), [page 40](#)

1.10.1 Removing and installing clutch master cylinder, up!

Special tools and workshop equipment required

- ◆ Torque wrench - V.A.G 1331-

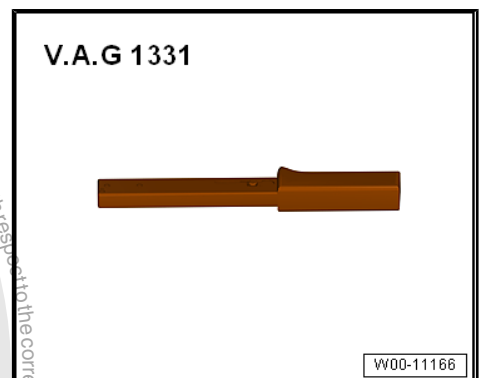

Removing

Remove mounting bracket with clutch master cylinder
⇒ [page 31](#) .



The figure shows installed mounting bracket with clutch master cylinder.

- Pull pivot pin -A- for plunger/clutch master cylinder in direction of -arrow 1- out of clutch pedal.
- Unscrew securing bolts -arrows 2- and remove clutch master cylinder from mounting bracket.
- Remove clutch master cylinder from mounting bracket.

Installing

Install in the reverse order of removal, observing the following.

- Renew seal for clutch master cylinder ⇒ [Item 2 \(page 16\)](#) .
- Renew pivot pin -A- after removing.
- Pivot pin -A- must audibly engage in clutch pedal.
- Ensure proper engagement by carefully pulling pivot pin.
- Install clutch master cylinder to mounting bracket using securing bolts -arrows 2-.

Specified torque ⇒ [page 16](#) .

Install mounting bracket with clutch master cylinder ⇒ [page 31](#) .

Specified torques

- ◆ Clutch master cylinder to mounting bracket ⇒ [page 16](#)

1.10.2 Removing and installing clutch master cylinder, Polo



Note

- ◆ *Before replacing the clutch master cylinder due a suspected defect, use [Guided Fault Finding](#) ⇒ Vehicle diagnostic tester.*
- ◆ *When performing work in the footwell, put cloths on the floor covering to protect it from possible brake fluid spills.*

Removing

- Remove mounting bracket with clutch master cylinder ⇒ [page 35](#) .
- Compress fasteners -1- on pivot pin for plunger/clutch master cylinder -arrows- (shown in illustration with mounting bracket installed).

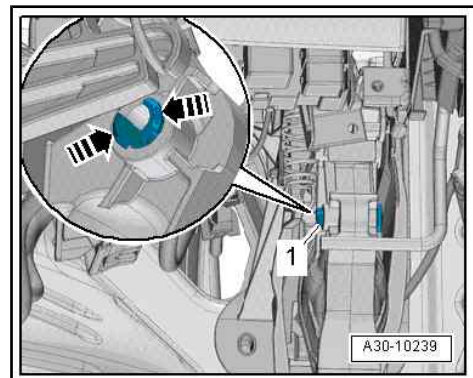
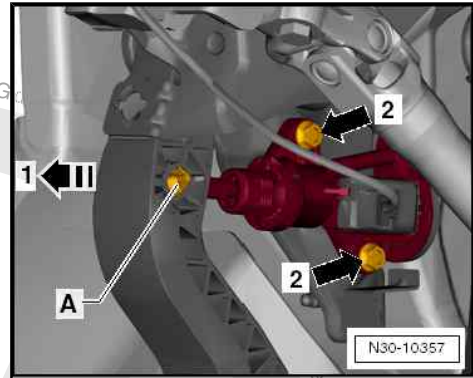



- Pull pivot pin for plunger/clutch master cylinder in direction of -arrow A- out of clutch pedal.

Clutch master cylinder is engaged in mounting bracket by means of catches -arrows B-.

- Release locking tabs -arrows B- from clutch master cylinder, and forcefully pull clutch master cylinder out of mounting bracket.

Illustration shows only 2 of 4 locking tabs -arrows B-.

Installing

Install in the reverse order of removal, observing the following.

- Renew seal for clutch master cylinder ⇒ [Item 5 \(page 18\)](#) .
- Renew pivot pin -arrow A- after removing.
- Pivot pin -arrow A- must audibly engage in clutch pedal.
- Ensure proper engagement by carefully pulling pivot pin.
- Engage clutch master cylinder in mounting bracket -arrows B-.
- Ensure proper engagement by carefully pulling clutch master cylinder.
- Install mounting bracket with clutch master cylinder ⇒ [page 35](#) .

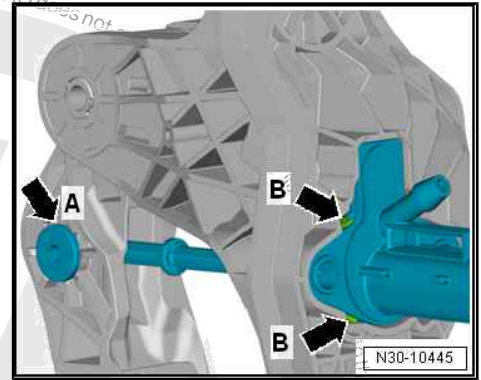

1.11 Removing and installing clutch slave cylinder

Special tools and workshop equipment required

- ◆ Hose clamps to 25 mm - 3094-

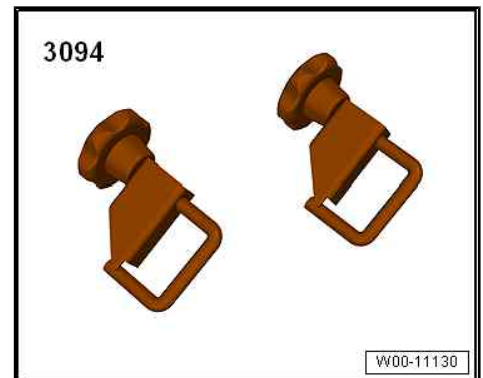

- ◆ Torque wrench - V.A.G 1331-

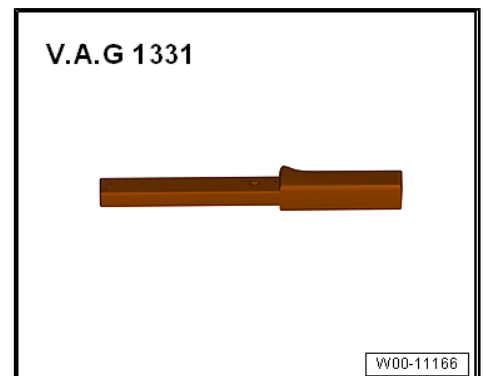



Removing



Note

- ◆ *Before replacing the clutch slave cylinder due a suspected defect, you must first use Guided Fault Finding ⇒ Vehicle diagnostic tester.*
- ◆ *Make sure you do not depress the clutch pedal if the clutch slave cylinder is removed from the gearbox with the pipe/hose assembly still attached. Otherwise the piston will be pressed out of the clutch slave cylinder and thus destroyed.*
- If air filter prevents access to clutch slave cylinder, it must be removed ⇒ Rep. gr. 24 ; Air filter; Removing and installing air filter housing .
- Remove battery and battery tray ⇒ Electrical system; Rep. gr. 27 ; Battery; Removing and installing battery .
- Remove starter ⇒ Electrical system; Rep. gr. 27 ; Starter; Assembly overview - starter .
- Remove gear selector cable, gate selector cable and cable support bracket from gearbox and tie it up ⇒ [page 65](#) .
- Lay a lint-free cloth under clutch slave cylinder.
- Release clip -A- with a screwdriver and disconnect pipe/hose line -B- from connection.
- Pull pipe/hose line -B- out of clutch slave cylinder and seal openings.
- Remove bolts -arrows- and remove clutch slave cylinder.

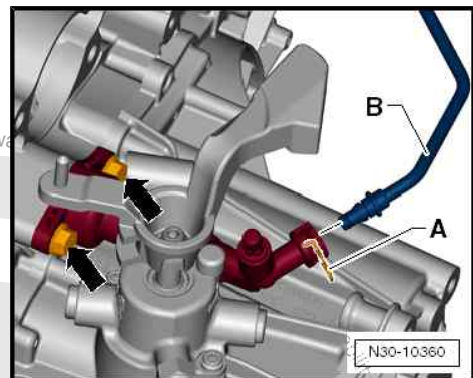

Installing

Install in the reverse order of removal, observing the following.

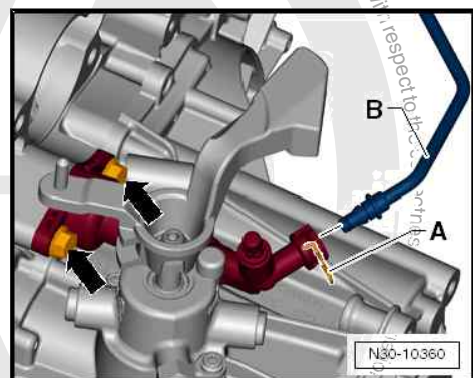



Disconnecting and connecting lines for clutch hydraulics

Disconnecting

- Release clip -3- with a screwdriver and disconnect pipe/hose line -1- from connection -4-.

Connecting



Note

- ◆ *It is also possible to install an O-ring instead of the seal -2- ⇒ [page 43](#) .*
- ◆ *Renew seal -2- if damaged.*
- Press pipe/hose line -1- into connection -4- until clip -3- engages audibly.
- Test pipe/hose line by tugging on it.

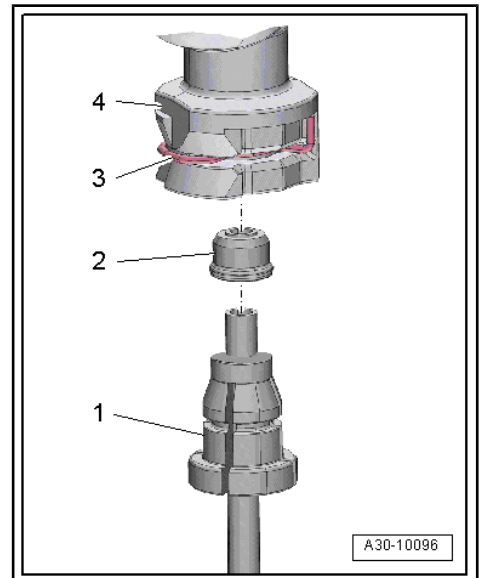

Seals and O-rings for pipe and hose lines

Item	Material of line connection
1	Line connection with circumferential groove -arrow 1-
2	Line connection with shoulder -arrow 2-
3	Line connection with shoulder -arrow 2- and circumferential groove -arrow 3-

- For line connection having circumferential groove -arrow 1- and -arrow 3-, a seal or O-ring must be set there.
- Bolt clutch slave cylinder to gearbox -arrows-.
- Insert pipe/hose assembly -B- into clutch slave cylinder as far as stop.
- Press in clip -A- to stop.
- Test line by tugging on it.
- Bleed clutch mechanism ⇒ [page 46](#) .
- Install gear selector cable, gate selector cable and cable support bracket ⇒ [page 65](#) .
- Adjust selector mechanism ⇒ [page 76](#) .
- Install starter ⇒ Electrical system; Rep. gr. 27 ; Starter; Assembly overview - starter .
- Install battery ⇒ Electrical system; Rep. gr. 27 ; Battery; Removing and installing battery .
- If air filter has been removed, it must be reinstalled now ⇒ Rep. gr. 24 ; Air filter; Removing and installing air filter housing .

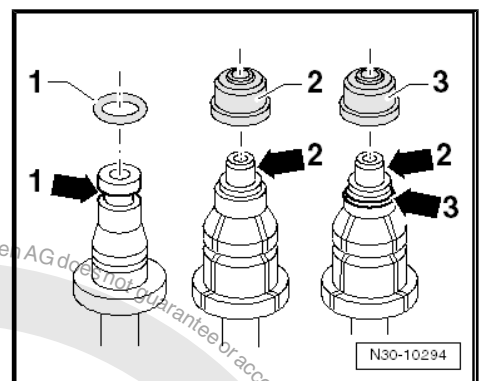

Specified torques

- ◆ Clutch slave cylinder to gearbox ⇒ [page 24](#)

1.12 Removing and installing lines for clutch mechanism

Special tools and workshop equipment required



- ◆ Hose clamps to 25 mm - 3094-

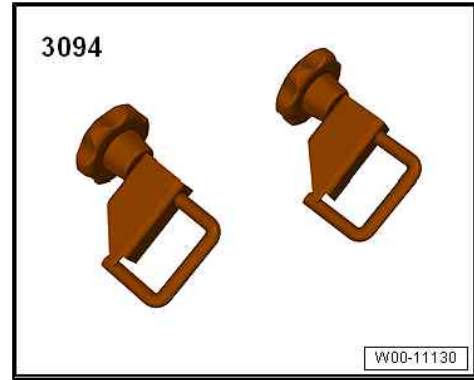

Removing

- Remove complete air filter housing if it prevents access to the lines for clutch mechanism ⇒ Rep. gr. 24 ; Air filter; Removing and installing air filter housing .
- Remove battery and battery tray ⇒ Electrical system; Rep. gr. 27 ; Battery; Removing and installing battery .

Polo, LHD vehicles

- Unclip engine control unit from bracket on plenum chamber bulkhead without disconnecting electrical connector, and lay it to one side ⇒ Rep. gr. 24 ; Engine control unit .

RHD vehicles

In some vehicles, master cylinder is located behind a line for air conditioning system -arrow-.

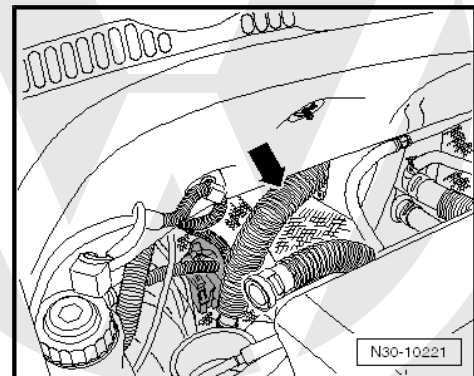

An insulation mat is installed in conjunction with some engines. Appearance may be different from that illustrated.

- Remove insulation mat. Note item -1 to 4-.

Continuation for all



Caution

Risk of leaking brake fluid.

- ◆ *During the following work, ensure that no brake fluid lands on longitudinal member or gearbox. If this does happen, clean the affected areas thoroughly.*
- ◆ *Lay a lint-free cloth under clutch master cylinder.*

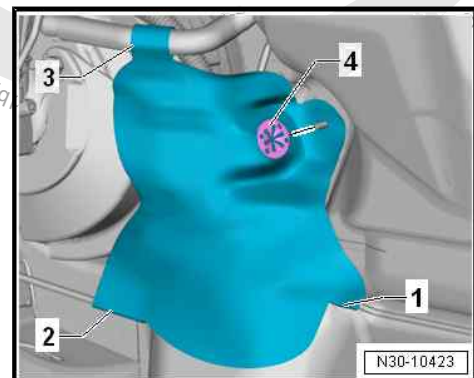



- Using hose clamp - 3094- , clamp off supply hose -2- to clutch master cylinder.

i Note

- ◆ *Clamping off the supply hose with the hose clamp - 3094- will cause a permanent deformation.*
- ◆ *However, this does not damage the supply hose.*
- ◆ *After removing the hose clamp - 3094- , the supply hose must be returned to its original shape.*

- Pull out clip for pipe/hose line -1- as far as stop, and remove pipe/hose line.
- Seal openings.
- Pull out clip -A- as far as stop and pull off pipe/hose line -B-.
- Seal openings.

i Note

Ignore -arrows-.

- Seal off open lines and connections if necessary with clean plugs from engine bung set - VAS 6122- .
- Move pipe/hose line clear and remove it.

Installing

Install in reverse order of removal, observing the following:

- Connect pipe/hose assembly -1- to clutch master cylinder and clutch slave cylinder.
- Test line by tugging on it.
- After removing the hose clamp - 3094- , the supply hose -2- must be returned to its original shape.

Polo, LHD vehicles

- Clip engine control unit with connector connected into bracket on plenum chamber bulkhead ⇒ Rep. gr. 24 ; Engine control unit .

Polo, RHD vehicles

- If fitted, fold insulation mat in the sequence -1, 2, 3- around lines.
- Secure insulation mat with lock washer -4-.

Continuation for all

- Bleed clutch mechanism ⇒ [page 46](#) .
- Install battery tray and battery ⇒ Electrical system; Rep. gr. 27 ; Battery; Removing and installing battery .
- Install complete air filter housing ⇒ Rep. gr. 24 ; Air filter; Removing and installing air filter housing .

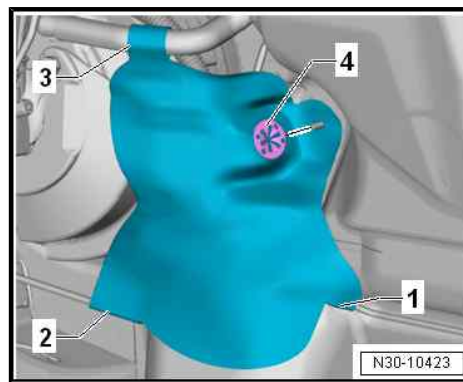
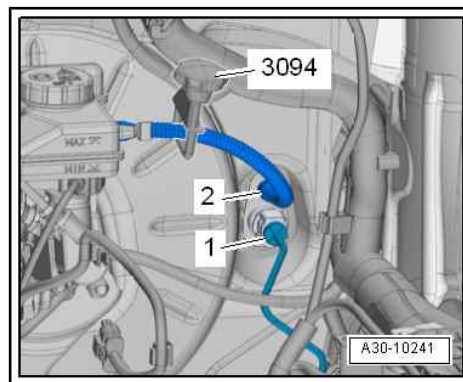
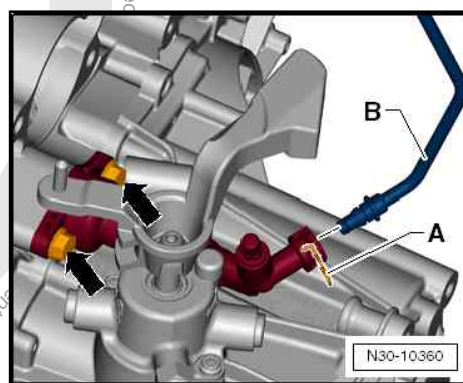
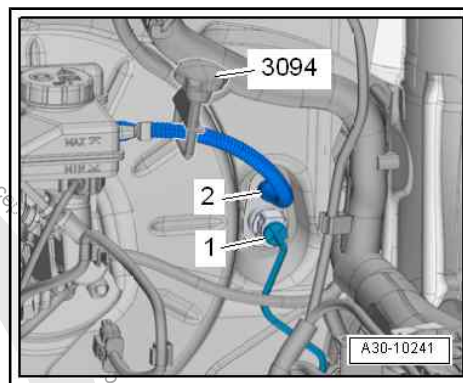



1.13 Bleeding clutch mechanism

Special tools and workshop equipment required

- ◆ Brake filling and bleeding unit - VAS 5234-

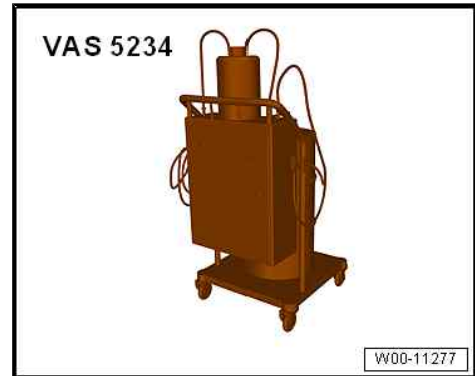

Note

- ◆ *The clutch mechanism must be bled after performing work on the hydraulic system.*
 - ◆ *During the following work, ensure that no brake fluid lands on longitudinal member or gearbox.*
 - ◆ *Pre-filling system is not necessary!*
 - ◆ *Before bleeding, fill brake fluid reservoir up to "max" marking with brake fluid.*
 - ◆ *Clutch pedal is at rest position, is not being depressed.*
 - ◆ *Brake fluid: Allocation ⇒ Electronic parts catalogue (ETKA) .*
- Remove complete air filter housing if it prevents access to bleeder valve (-arrow- in illustration below) ⇒ Rep. gr. 24 ; Air filter; Removing and installing air filter housing .

Polo

- Remove protective cap from bleeder valve -arrow-.

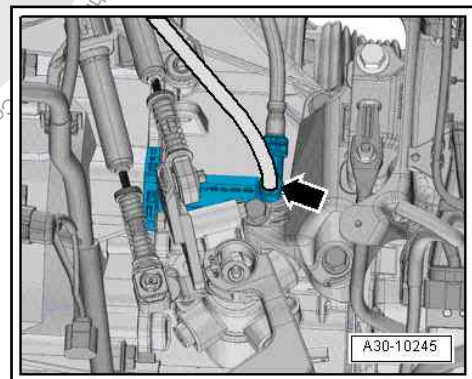



up!

- Raise vehicle.

Clutch slave cylinder -arrow 1- is accessible from beneath vehicle on left-hand side, in vicinity of gearbox selector lever -arrow 2-.

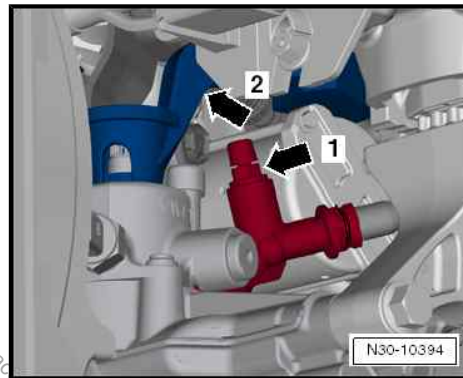

Continuation for all

- Remove protective cap from bleeder valve -arrow-.
- Connect brake filling and bleeding equipment .

To bleed system, use 670 mm bleeder hose - V.A.G 1238/B3- if necessary.

- To do this, connect the bleeder hose to the collector bottle of the brake bleeding device.
- Connect bleeder hose to bleeder valve -arrow- (illustrated in top view).
- Switch on brake filling and bleeding equipment .
- Working pressure 2.0 bar.
- Open bleeder valve.
- Allow about 100 cm³ of brake fluid to flow out.
- Close bleeder valve.
- Rapidly operate pedal from stop to stop 10 to 15 times.
- Open bleeder valve.
- Allow another 50 cm³ of brake fluid to flow out.
- Close bleeder valve.
- Switch off brake filling and bleeding equipment and relieve pressure completely from equipment.
- Depress clutch pedal several times after completion of bleeding process.

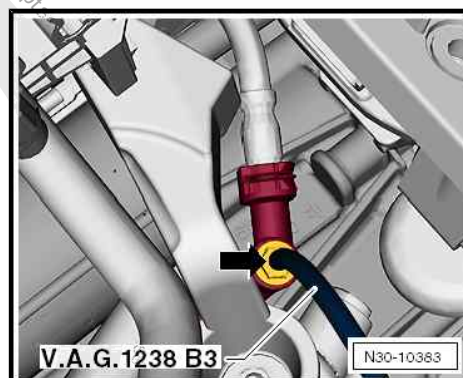

Specified torque:

Component	Nm
Bleeder valve	4.5

1.14 Removing and installing clutch pedal switch - F36-

To ensure sufficiently secure seating in mounting bracket for clutch pedal, clutch pedal switch - F36- may be installed only once.

Removing

- Remove driver side footwell cover => General body repairs, interior; Rep. gr. 68 ; Compartments/covers; Removing and installing dash panel end trim on driver side .
- Pull connector off clutch pedal switch - F36- .



- Turn clutch pedal switch - F36- on mounting bracket 45° in direction of -arrow- and pull out of support.

Installing

- Grease plunger.
- Allocate grease using ⇒ Electronic parts catalogue (ETKA) .

Clutch pedal switch - F36- is installed from passenger compartment.

- Clutch pedal must always remain in rest position when clutch pedal switch - F36- is being installed. During entire installation procedure, clutch pedal is only allowed to be touched with plunger head of clutch pedal switch - F36- .
- Insert clutch pedal switch - F36- into mounting bracket support and turn 45° in direction of -arrow-.
- Push connector onto clutch pedal switch - F36- .
- Install driver side footwell cover ⇒ General body repairs, interior; Rep. gr. 68 ; Compartments/covers; Removing and installing dash panel end trim on driver side .

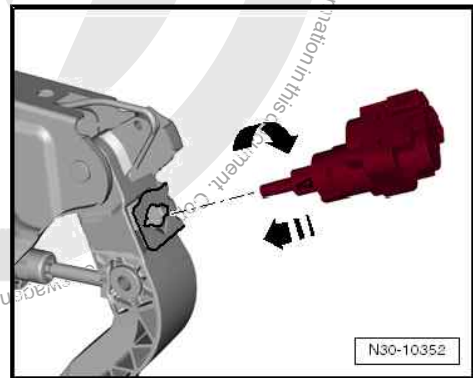
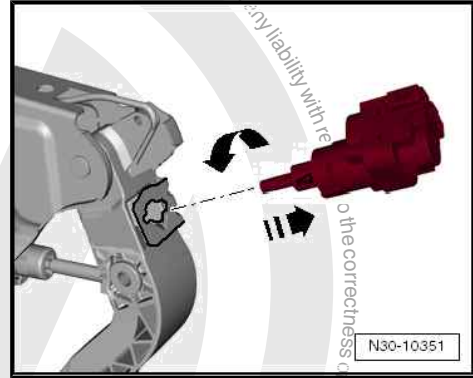

1.15 Checking clutch master cylinder and clutch slave cylinder

Carry out Guided Fault Finding using ⇒ Vehicle diagnostic tester before renewing clutch master cylinder due to suspected fault.

1.16 Removing and installing clutch position sender - G476-

⇒ ["1.16.1 Removing and installing clutch position sender G476 , up! ", page 48](#)

⇒ ["1.16.2 Removing and installing clutch position sender G476 , Polo ", page 49](#)

1.16.1 Removing and installing clutch position sender - G476- , up!

Removing

- Unclip clutch position sender - G476- from clutch master cylinder -arrow A- and remove from fitting location -arrow B-.
- Remove clutch position sender - G476- from master cylinder, and disconnect connector.

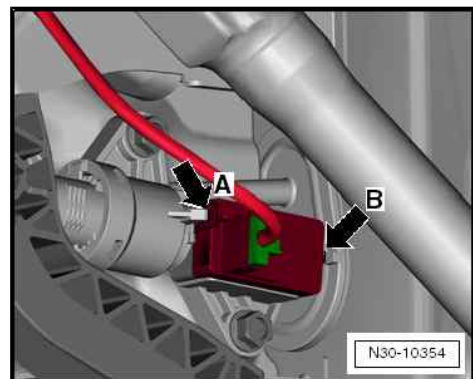



Installing

- Fit clutch position sender - G476- on clutch master cylinder into fitting location -arrow B- and clip it in -arrow A-.
- Test clutch position sender - G476- by tugging on it.
- Connect electrical connector.

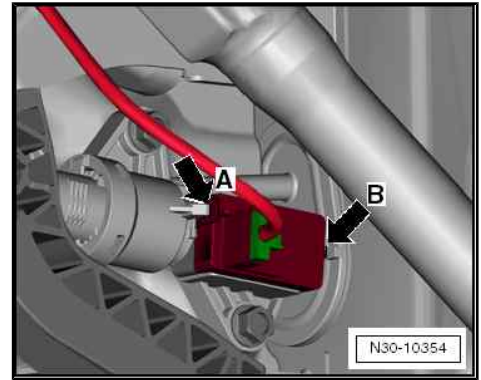

1.16.2 Removing and installing clutch position sender - G476- , Polo

Special tools and workshop equipment required

- ◆ Hook - 3438-

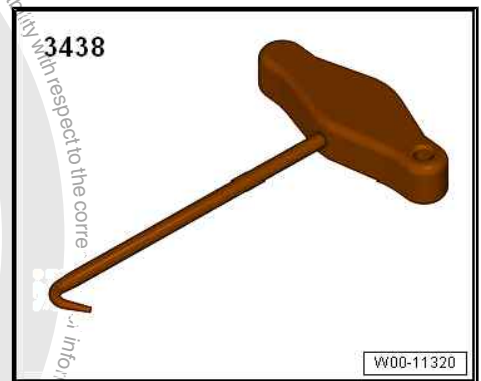

Removing

- Disconnect battery => Electrical system; Rep. gr. 27 ; Battery; Disconnecting and connecting battery .

LHD vehicles

- Unclip engine control unit from bracket on plenum chamber bulkhead without disconnecting electrical connector, and lay it to one side => Rep. gr. 24 ; Engine control unit .

RHD vehicles

In some vehicles, master cylinder is located behind a line for air conditioning system -arrow-.

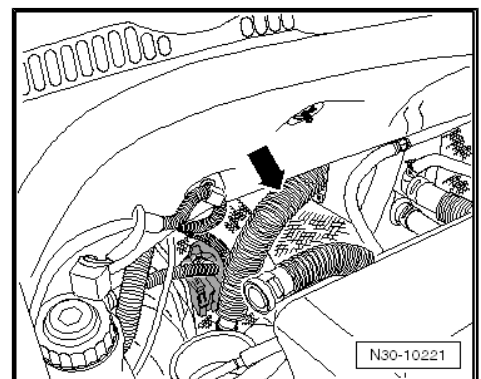



An insulation mat is installed in conjunction with some engines. Appearance may be different from that illustrated.

- Remove insulation mat. Note item -1 to 4-.

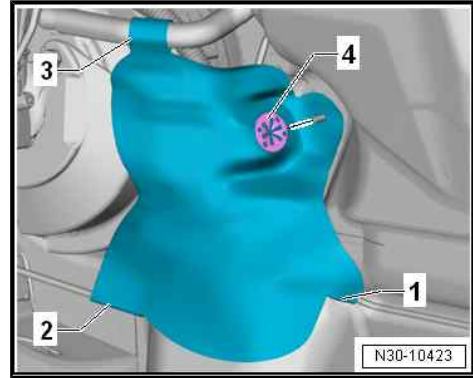

Continuation for all

- Unclip clutch position sender - G476- on master cylinder -arrow A- and -arrow B-.
- Remove clutch position sender - G476- from master cylinder, and disconnect connector.

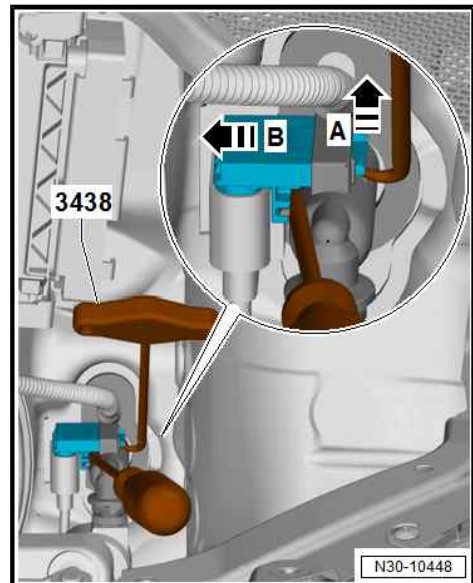

Installing

- Insert clutch position sender - G476- into master cylinder with electrical connector connected. Push it in as far as stop.
- Clutch position sender - G476- must clip in -arrow A-.
- To check, pull on clutch position sender - G476- -arrow B-.
- Disregard items -1, 2 and 3-.

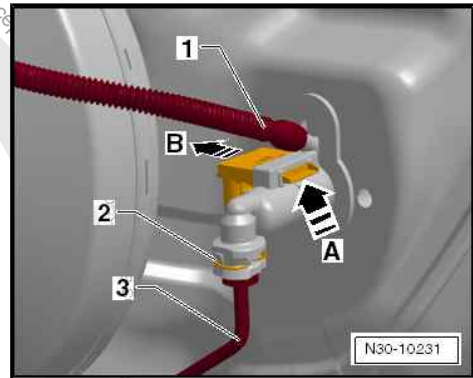

- If fitted, fold insulation mat in the sequence -1, 2, 3- around lines.
- Secure insulation mat with lock washer -4-.

LHD vehicles

- Clip engine control unit with connector connected into bracket on plenum chamber bulkhead => Rep. gr. 24 ; Engine control unit .

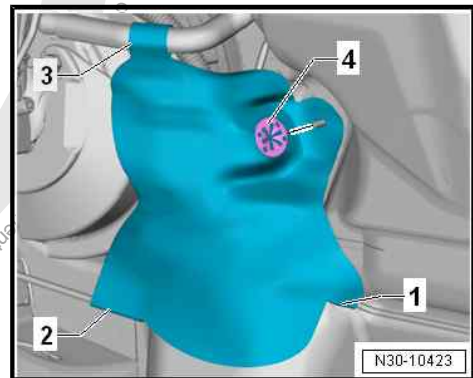



1.17 Repairing clutch release mechanism

Special tools and workshop equipment required

- ◆ Torque wrench - V.A.G 1331-

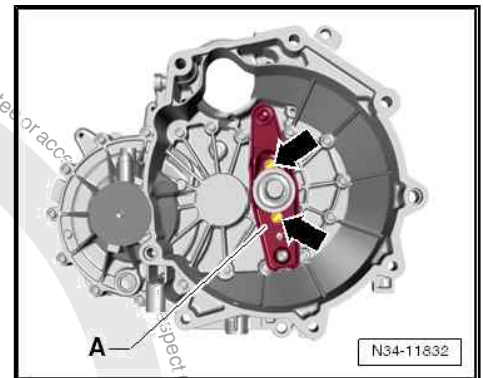

Removing and installing clutch release lever -A- with release bearing and guide sleeve

- Gearbox has been removed.
- Unscrew bolts -arrows-.
- Pull clutch release lever with release bearing and guide sleeve off input shaft and ball stud.

Install in reverse order of removal.

- Install gearbox
⇒ [page 101](#) .

Specified torques

- Guide sleeve to gearbox ⇒ [page 24](#)

Removing and installing guide sleeve from/to clutch release bearing

- Remove clutch release lever together with release bearing and guide sleeve ⇒ [page 51](#) .
- Push guide sleeve -3- upwards out of release bearing -2-.
- Turn guide sleeve -3- about 90° in direction of arrow relative to release bearing -2- until locking lugs of guide sleeve align with grooves -4- of release bearing.
- Pull guide sleeve out of release bearing in this position.

Install in reverse order of removal.

- Install clutch release lever together with release bearing and guide sleeve ⇒ [page 51](#) .

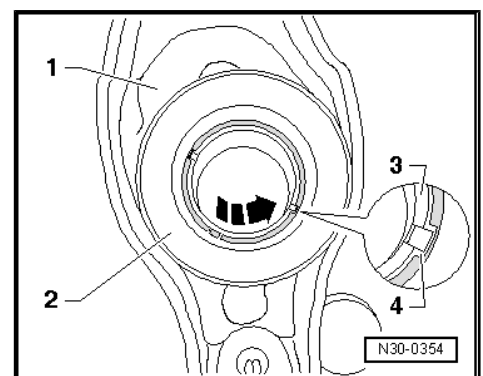



Removing and installing release bearing

- Remove clutch release lever together with release bearing and guide sleeve ⇒ [page 51](#) .
- Press together locking lugs -arrows- on back of clutch release lever and remove release bearing -A- from clutch release lever.
- To install, press release bearing -A- into clutch release lever until retaining lugs -arrows- engage.
- Grease contact surface for clutch release lever on ball-head pin with grease for clutch plate splines .
- Install clutch release lever together with release bearing and guide sleeve ⇒ [page 51](#) .

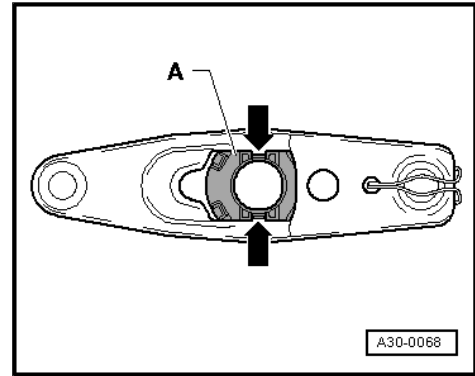



2 Clutch

⇒ ["2.1 Assembly overview - clutch", page 53](#)

⇒ ["2.2 Removing and installing clutch", page 54](#)

2.1 Assembly overview - clutch

1 - Flywheel

- ❑ Removing and installing
⇒ Rep. gr. 13 ; Cylinder block (gearbox end);
Removing and installing flywheel .
- ❑ Ensure that centring pins fit tightly
- ❑ Keep contact surface for clutch lining free of grooves, oil and grease

2 - Clutch plate

- ❑ Allocation ⇒ Electronic parts catalogue (ETKA)
- ❑ Centring ⇒ [page 54](#)

3 - Thrust plate

- ❑ Removing and installing
⇒ [page 54](#)
- ❑ Check ends of diaphragm spring
⇒ [page 56](#)
- ❑ Check spring connections and riveted connections ⇒ [page 56](#) .

4 - Bolt

- ❑ Allocation ⇒ Electronic parts catalogue (ETKA)
- ❑ Loosen or tighten alternately and diagonally in small steps (1 full turn)
- ❑ M 6: 13 Nm
- ❑ M 7: 20 Nm

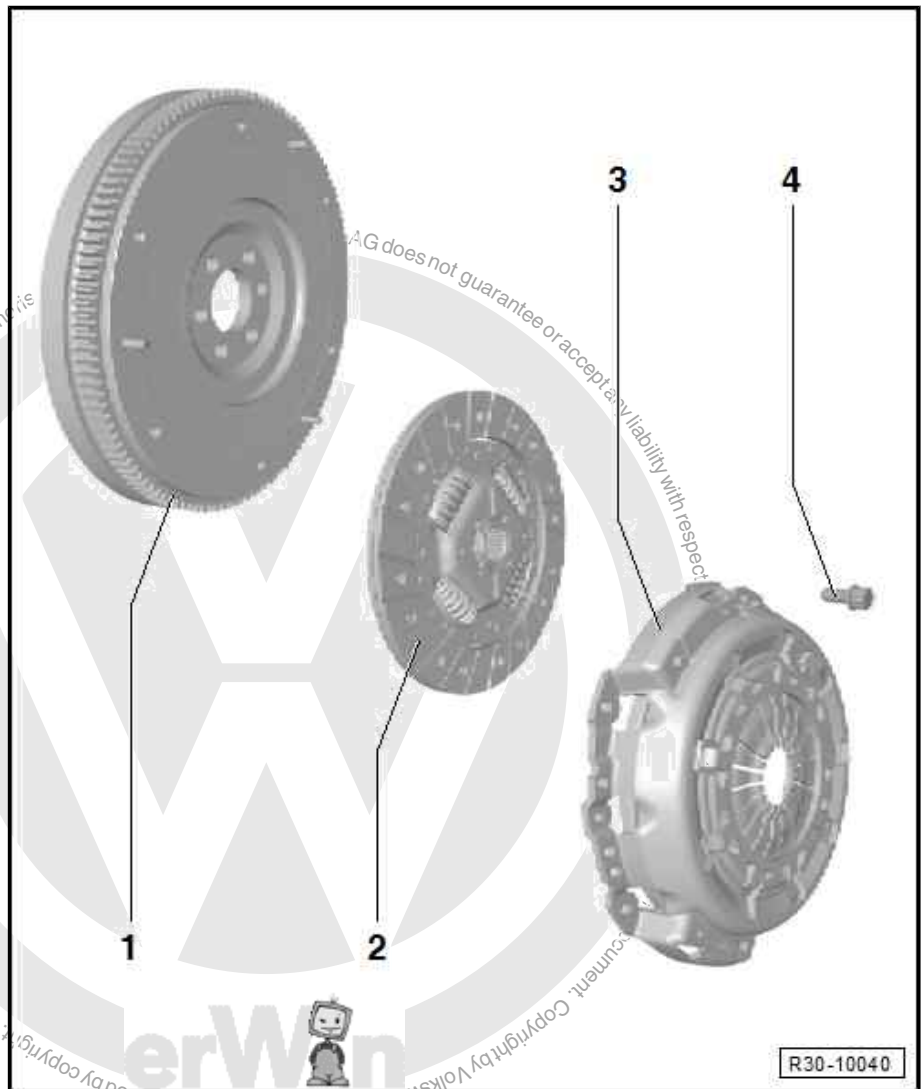

R30-10040



2.2 Removing and installing clutch

Special tools and workshop equipment required



- ◆ Counter-hold tool - 3067-
- ◆ Centring pin - 3190 A-
- ◆ Torque wrench - V.A.G 1331-
- ◆ Grease for splines
- ◆ Allocate grease using ⇒ Electronic parts catalogue (ETKA) .

Removing

- Gearbox is removed.



- Use counter-hold tool - 3067- to loosen bolts.

To prevent the pressure plate from becoming distorted during removal (causes clutch grab when driving off), always keep to the following procedure when unbolting the pressure plate:

- Loosen all bolts alternately and diagonally in small steps (1 full turn).
- Remove pressure plate and clutch plate.

Installing



Note

- ◆ Allocate clutch plate and clutch pressure plate according to engine code and ⇒ *Electronic parts catalogue (ETKA)*.
 - ◆ Clean splines of drive shaft and, if the clutch plate has been used, clean the splines of the hub. Remove corrosion and apply a very thin coat of clutch plate spline grease to splines. Then, move the clutch plate back and forth on the drive shaft until the hub moves easily on the shaft. Remove excess grease.
 - ◆ Clutch pressure plates are protected against corrosion and greased. With the exception of the friction surface for the clutch plate, the clutch pressure plate must not be cleaned. Service life of clutch will otherwise be shortened considerably.
 - ◆ The friction surface of the clutch pressure plate and the flywheel must be cleaned (degreased) thoroughly.
 - ◆ If the clutch has burnt out, thoroughly clean the gearbox in the area of the clutch as well as parts of the engine facing the gearbox in order to reduce the smell of burnt linings.
 - ◆ Clutch plate linings must make full contact with flywheel and friction surface of clutch pressure plate. Only then insert securing bolts.
 - ◆ Tighten securing bolts in small steps (1 full turn) diagonally in order not to damage centring holes of pressure plate and centring pins of flywheel.
 - ◆ Check whether dowel sleeves for aligning engine and gearbox are fitted in cylinder block and install if necessary.
 - ◆ If dowel sleeves are not fitted, difficulties shifting gears, clutch problems and possible noises from the gearbox (rattling of gears which are not engaged) could occur.
- Installation position of clutch plate: lettering "Getriebeseite" (gearbox end) or spring cage faces pressure plate.

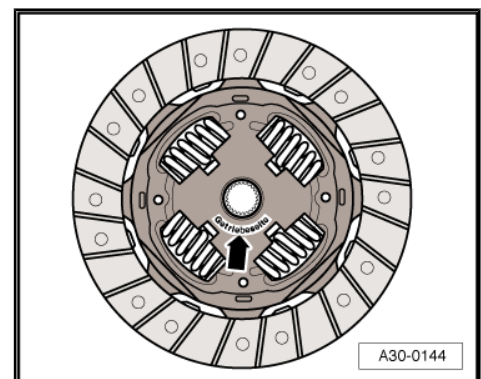
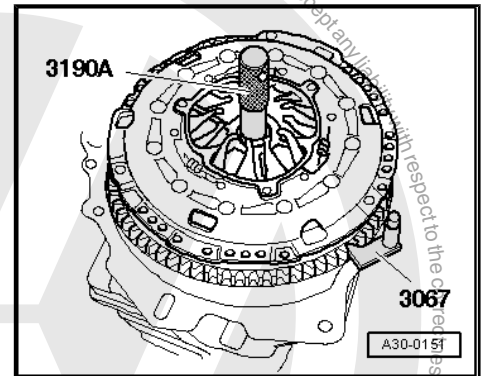



Check ends of diaphragm spring

- Wear to half the thickness of the diaphragm spring -arrows- is permitted.



Check spring connection and riveted fastenings.

- Check spring connection between thrust plate and cover for cracks and make sure rivet fastenings are seated tightly.
- If pressure plate has damaged springs or loose rivet connections -arrows-, it must be renewed.

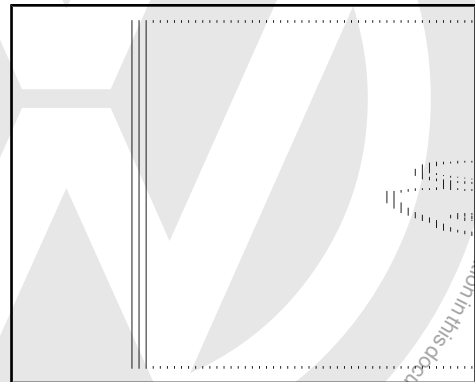

Check extension springs and riveted connections

I - Extension springs OK.

- Minor kinks on the outside area -arrows A- have series production status.

II - Extension springs damaged

- Renew clutch pressure plates if springs are broken or badly bent -arrow B-.
- Check spring connections -arrows A- for damage, and make sure that rivet joints -arrows B- are firmly seated.
- Renew clutch pressure plate if spring connections are broken or badly bent, or if riveting is loose.

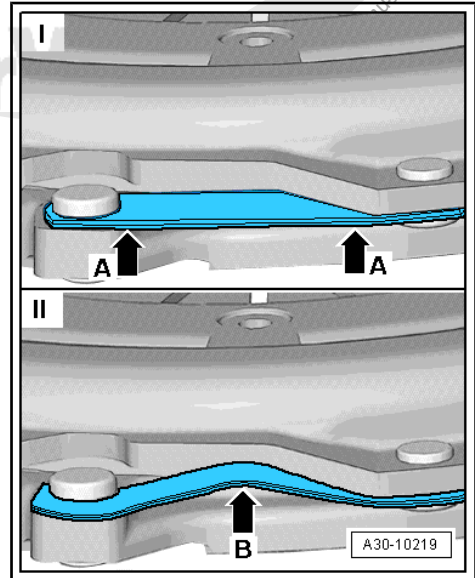

- Make sure rivet joints -arrows B- on all extension springs -arrows A- are firmly seated.
- Tighten all bolts one after another (clockwise) to final torque.
- Renew clutch pressure plate if riveting -arrow B- is loose.

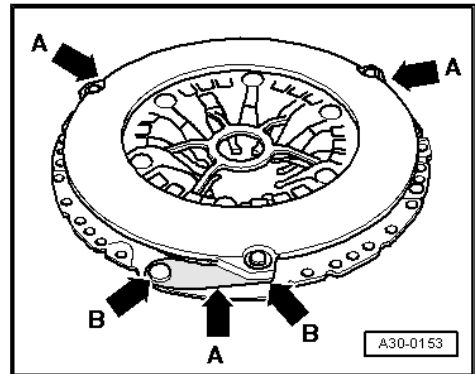



Check metal ring.

- Check that metal ring in clutch pressure plate -arrow- is not damaged.
- Renew clutch pressure plate if metal ring is broken.

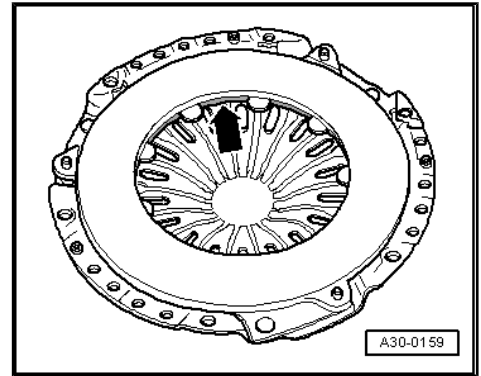

Centring clutch plate

- Tighten all bolts alternately and diagonally in small steps (1 full turn).
- Install gearbox ⇒ [page 101](#) .

Specified torques

- ◆ Pressure plate to flywheel ⇒ [page 53](#) .

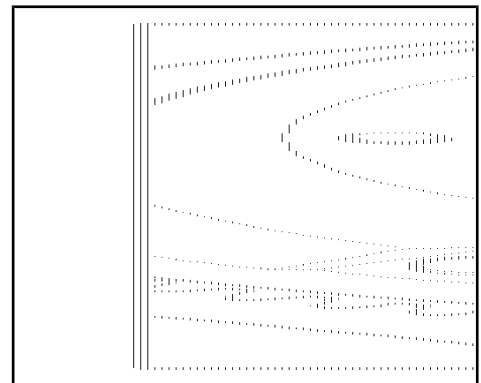



34 – Controls, housing

1 Selector mechanism

⇒ [“1.1 Installation position - selector mechanism”, page 58](#)

⇒ [“1.2 Overview - selector mechanism”, page 60](#)

⇒ [“1.3 Assembly overview - gear knob and cover”, page 61](#)

⇒ [“1.4 Assembly overview - Gear lever and selector housing”, page 62](#)

⇒ [“1.5 Assembly overview - Selector cables”, page 65](#)

⇒ [“1.6 Removing and installing gear knob”, page 67](#) .

⇒ [“1.7 Emblem identification”, page 69](#) .

⇒ [“1.8 Removing and installing selector mechanism”, page 69](#) .

⇒ [“1.9 Repairing selector mechanism”, page 72](#)

⇒ [“1.10 Adjusting selector mechanism”, page 76](#) .

⇒ [“1.11 Checking selector mechanism”, page 78](#) .

⇒ [“1.12 Dismantling and assembling selector mechanism”, page 78](#)

⇒ [“1.13 Removing and installing selector cable”, page 82](#)

⇒ [“1.14 Renewing selector shaft seal”, page 83](#)

1.1 Installation position - selector mechanism



Note

- ◆ *Disconnect battery before working on selector mechanism in engine compartment ⇒ [Electrical system](#); [Rep. gr. 27](#) ; [Battery](#); [Disconnecting and connecting battery](#) .*
- ◆ *Removing and installing selector mechanism ⇒ [page 69](#) .*

-Arrow A- indicates the gear selection movement and gear selector cable.

-Arrow B- indicates the gate selection movement and gear selector cable.



I - up! ⇒ 02 14 - gear lever is "not" pushed down to engage reverse gear

II - Polo and up! 03 14 ⇒ - gear lever "is" pushed down to engage reverse gear

A - Gear selector cable

B - Gate selector cable

C - Heat shield

- Remove before removing selector mechanism.

1 - Gearbox selector lever

2 - Relay lever

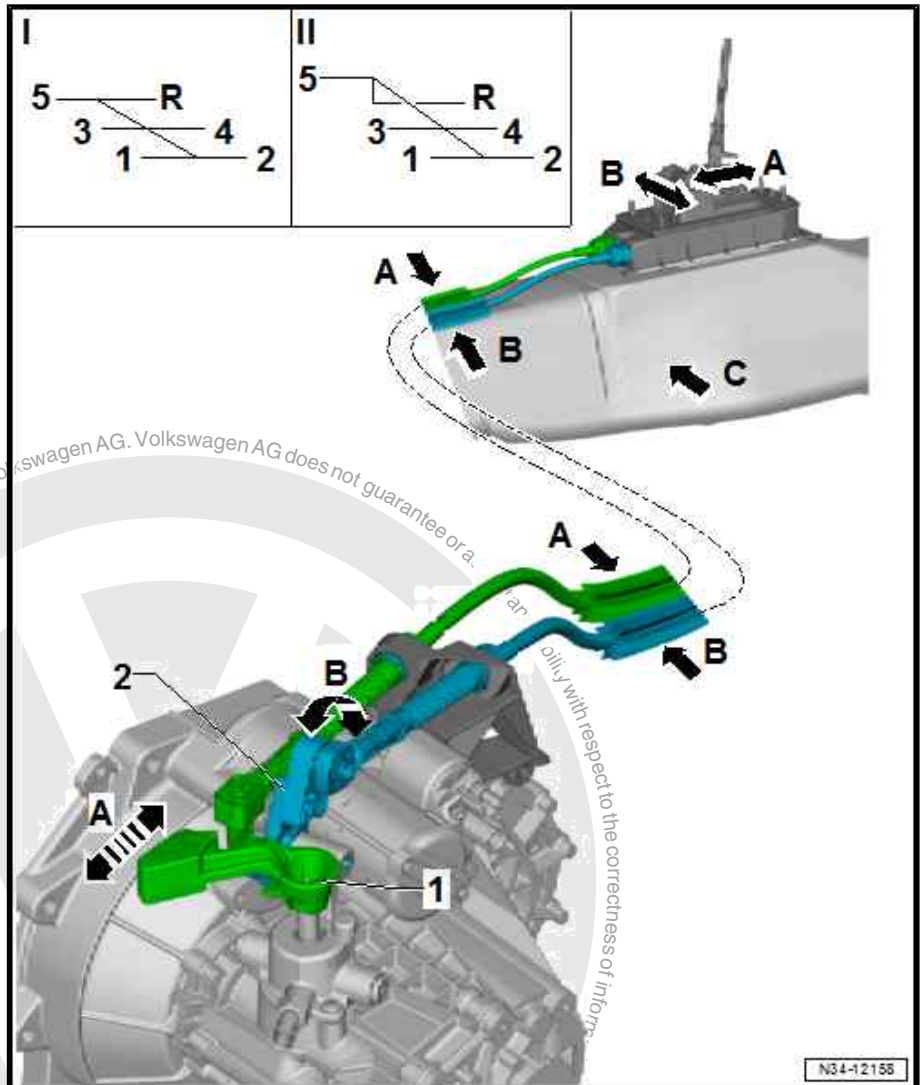

N34-12158



1.2 Overview - selector mechanism

I -
⇒ ["1.3 Assembly overview - gear knob and cover", page 61](#) .

II -
⇒ ["1.4 Assembly overview - Gear lever and selector housing", page 62](#) .

III -
⇒ ["1.5 Assembly overview - Selector cables", page 65](#) .

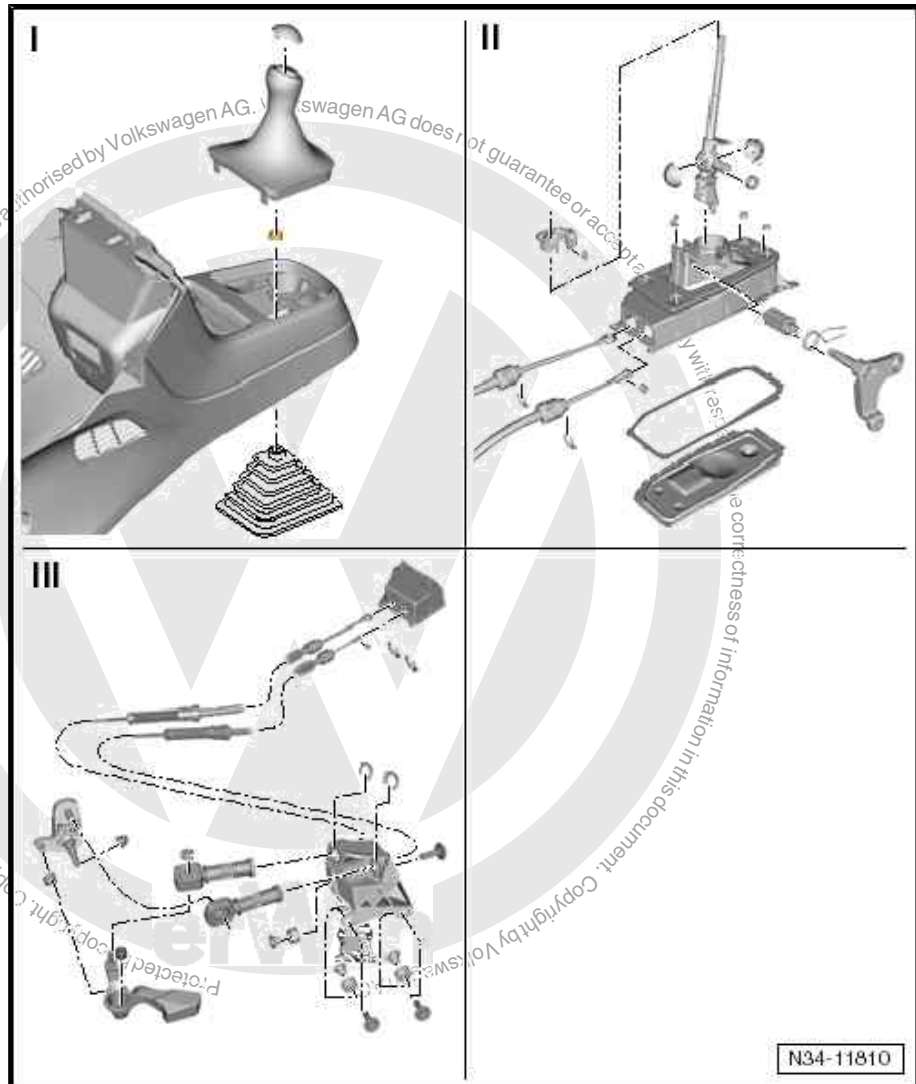



1.3 Assembly overview - gear knob and cover

1 - Emblem

- Can be carefully levered off gear knob of plastic or leather
- Different versions for following configurations:
- Gear lever is NOT "pushed down" to engage reverse gear
- Gear lever is "pushed down" to engage reverse gear
- Distinguishing
⇒ [page 69](#)
- Allocation of emblem ⇒ Electronic parts catalogue (ETKA)

2 - Gear knob

- With gaiter
- Gear knob and gaiter cannot be separated from one another
- Always renew together
- Removing and installing
⇒ [page 67](#)
- Different gear knob sizes in receptacle for gear lever on following configurations:
- Gear lever is NOT "pushed down" to engage reverse gear
- Gear lever is "pushed down" to engage reverse gear
- Allocation ⇒ Electronic parts catalogue (ETKA)

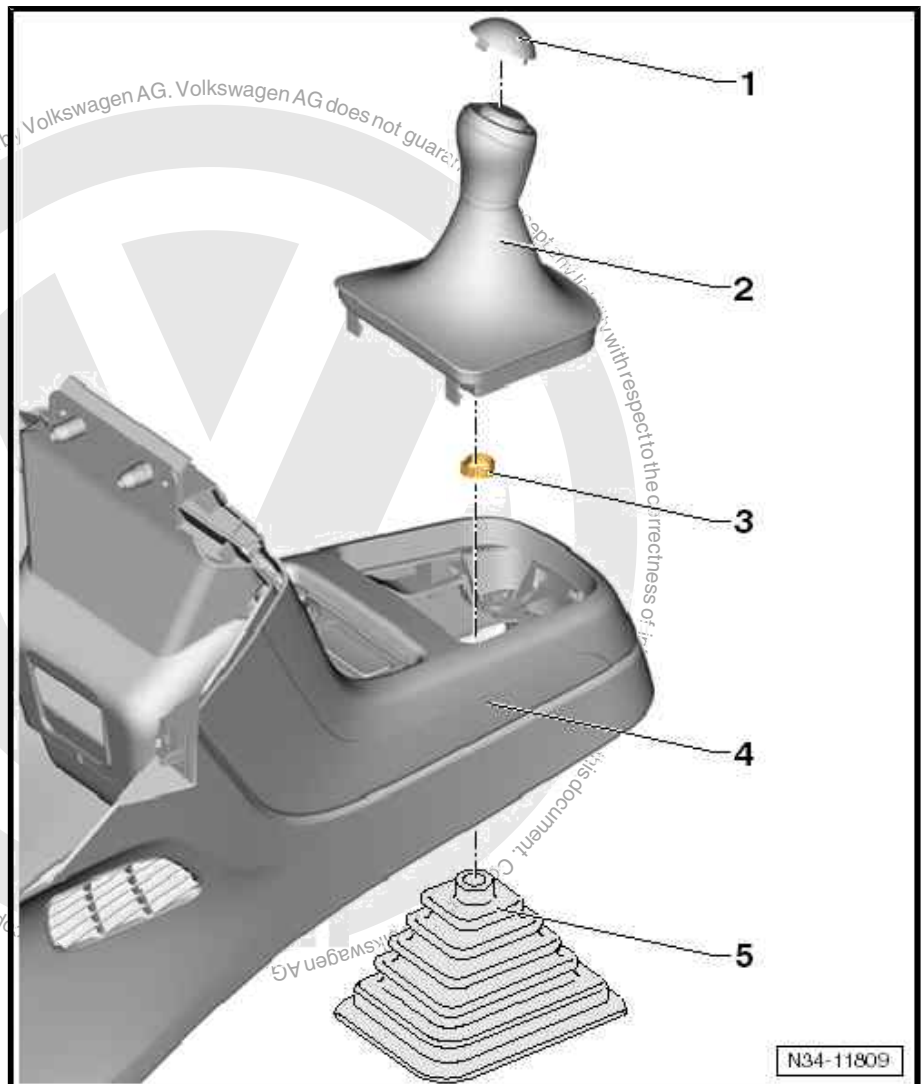

3 - Clip

- For securing gear knob to gear lever
- Renew after removal
- Secure to gear knob using hose clip pliers - V.A.G 1275 A-

4 - Centre console, upper part

- up!: forms one part with centre console cover
- In some equipment versions, centre console cover is an individual part
- Allocation ⇒ Electronic parts catalogue (ETKA)

5 - Noise insulation

- Not fitted in all vehicles
- Arrow on noise insulation points in direction of travel
- Locking lugs are arranged at varying intervals
- Therefore it can be installed in only one position



1.4 Assembly overview - Gear lever and selector housing

⇒ **“1.4.1 Assembly overview – gear lever and selector housing; gear lever is NOT pushed down to engage reverse gear”, page 62**

⇒ **“1.4.2 Assembly overview – gear lever and selector housing; gear lever is pushed down to engage reverse gear”, page 64**

1.4.1 Assembly overview – gear lever and selector housing; gear lever is NOT “pushed down” to engage reverse gear



Note

- ◆ Lubricate bearing positions and sliding surfaces.
- ◆ Allocate grease using ⇒ *Electronic parts catalogue (ETKA)* .

1 - Floor panel

- Bend open tabs to remove
- Fitting ⇒ [page 78](#)

2 - Seal

- Renew base plate after removing.

3 - Selector housing

4 - Securing clip

- Do not damage cables when removing
- Renew after removal

5 - Bush

6 - Gate change cable

- Lever off gate selector lever
- Press onto gate selector lever inside selector mechanism
- Fitting position ⇒ [page 58](#)

7 - Gear change cable

- Lever off gear lever guide
- Press onto gear lever guide inside selector mechanism
- Fitting position ⇒ [page 58](#)

8 - Bearing shell

- Is damaged during removal
- Renew after removal

9 - Dampers

- Removing and installing ⇒ [page 63](#)

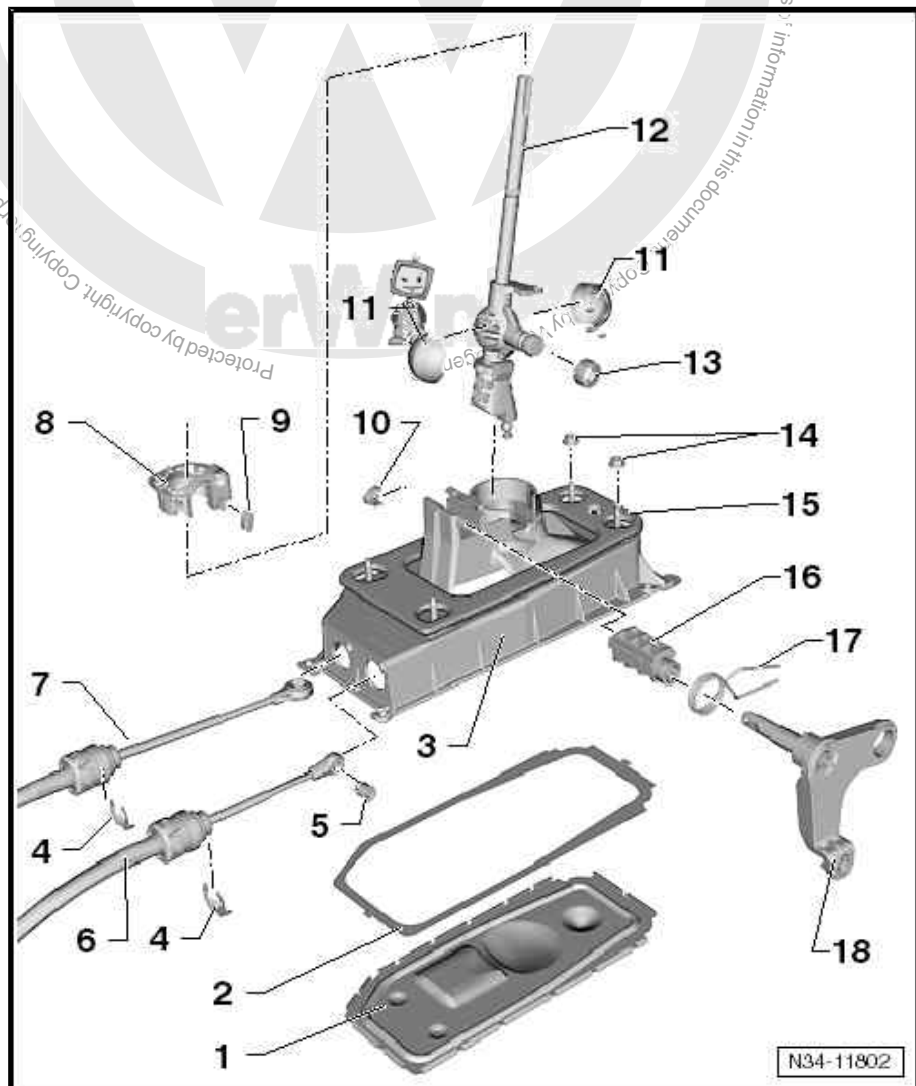



10 - Clip

- Secures gate selector lever.
- Check for damage

11 - Bearing shell

- Fitting position ⇒ [page 80](#)
- Fit onto gear lever.
- Gear lever and ball sockets are listed as one replacement part.

12 - Gear lever

- Gear lever and ball sockets are listed as one replacement part.

13 - Bearing bush

- Fitting position ⇒ [page 80](#)
- Fit onto gear lever.
- Supports gear lever in gate selector lever.

14 - Hexagon nut

- Qty. 4
- M 6: 8 Nm
- M 8: 20 Nm

15 - Seal

- Between selector housing and underbody
- Renew selector housing after removing
- Self-adhesive
- Bond to selector lever housing

16 - Bearing bush

- Fitting position ⇒ [page 81](#)

17 - Compression spring

18 - Gate selector lever

Removing and installing damping -arrow-

- Press lug -A- of spring to right until it is next to damping -arrow-.
- Move gear lever to right and pull off damping.
- After installation, damping must contact extensions -A- and -B-.

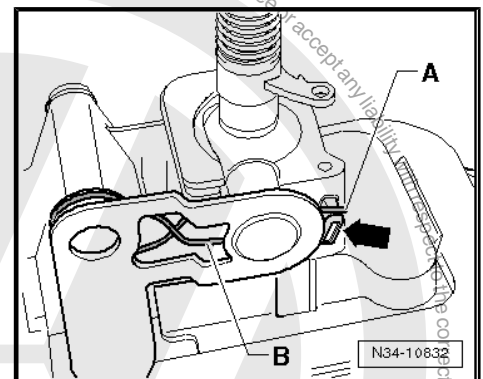



1.4.2 Assembly overview – gear lever and selector housing; gear lever is “pushed down” to engage reverse gear

1 - Selector mechanism

- Gear lever is “pushed down” to engage reverse gear
- Cannot be disassembled
- Gear selector cable and gate selector cable cannot be removed
- Removing and installing ⇒ [page 69](#)

2 - Seal

- Self-adhesive
- Renew after each removal of selector mechanism

3 - Hexagon nut

- Qty. 4
- M 6: 8 Nm
- M 8: 20 Nm

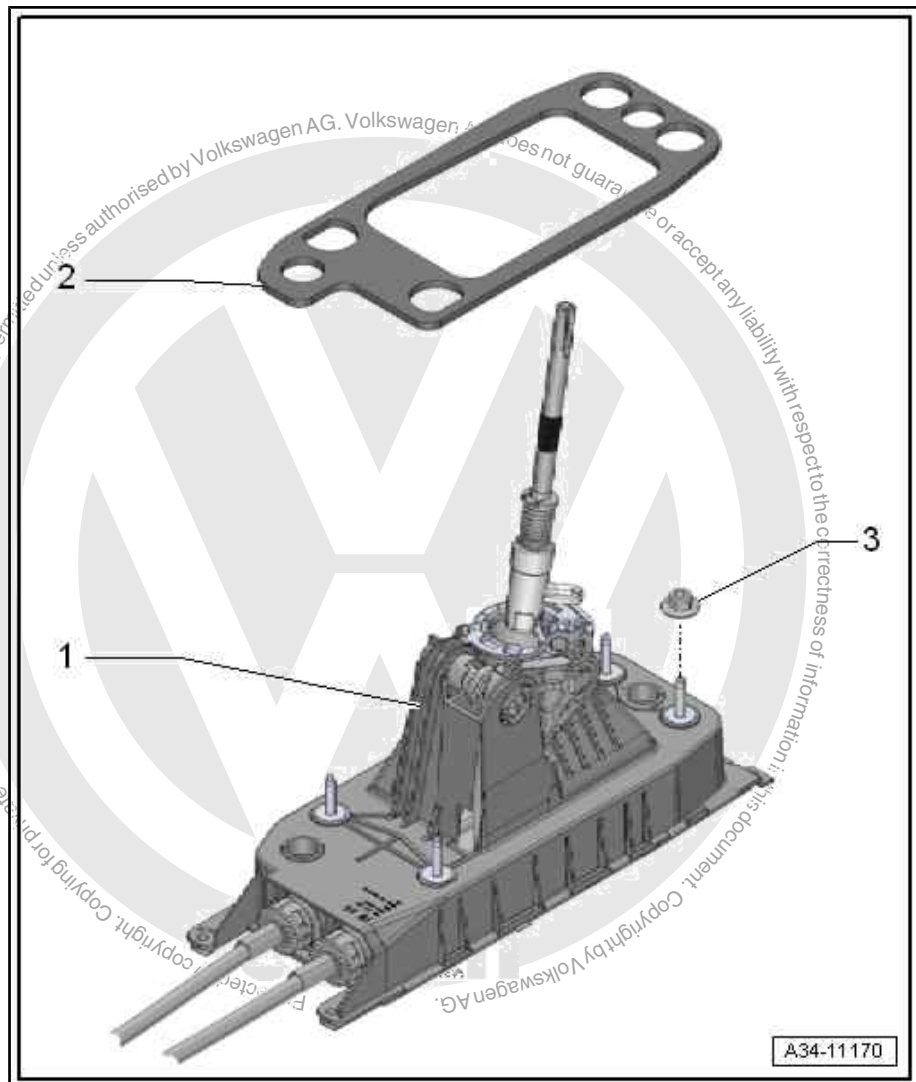



1.5 Assembly overview - Selector cables



Note

- ◆ Lubricate bearing positions and sliding surfaces.
- ◆ Allocate grease using ⇒ *Electronic parts catalogue (ETKA)*.

1 - Gear change cable

- Connect to cable end-piece
⇒ [Item 12 \(page 66\)](#).
- Fitting position
⇒ [page 58](#)
- Gear lever is "NOT" pushed down to engage reverse gear: gear selector cable and gate selector cable can be removed from selector housing (only up! ⇒ 02 14)
- Gear lever is pushed "down" to engage reverse gear: gear selector cable and gate selector cable cannot be removed from selector housing (Polo and up! 03 14 ⇒)

2 - Gate change cable

- Connect to cable end-piece
⇒ [Item 10 \(page 66\)](#).
- Fitting position
⇒ [page 58](#)
- Gear lever is "NOT" pushed down to engage reverse gear: gear selector cable and gate selector cable can be removed from selector housing (only up! ⇒ 02 14)
- Gear lever is pushed "down" to engage reverse gear: gear selector cable and gate selector cable cannot be removed from selector housing (Polo and up! 03 14 ⇒)

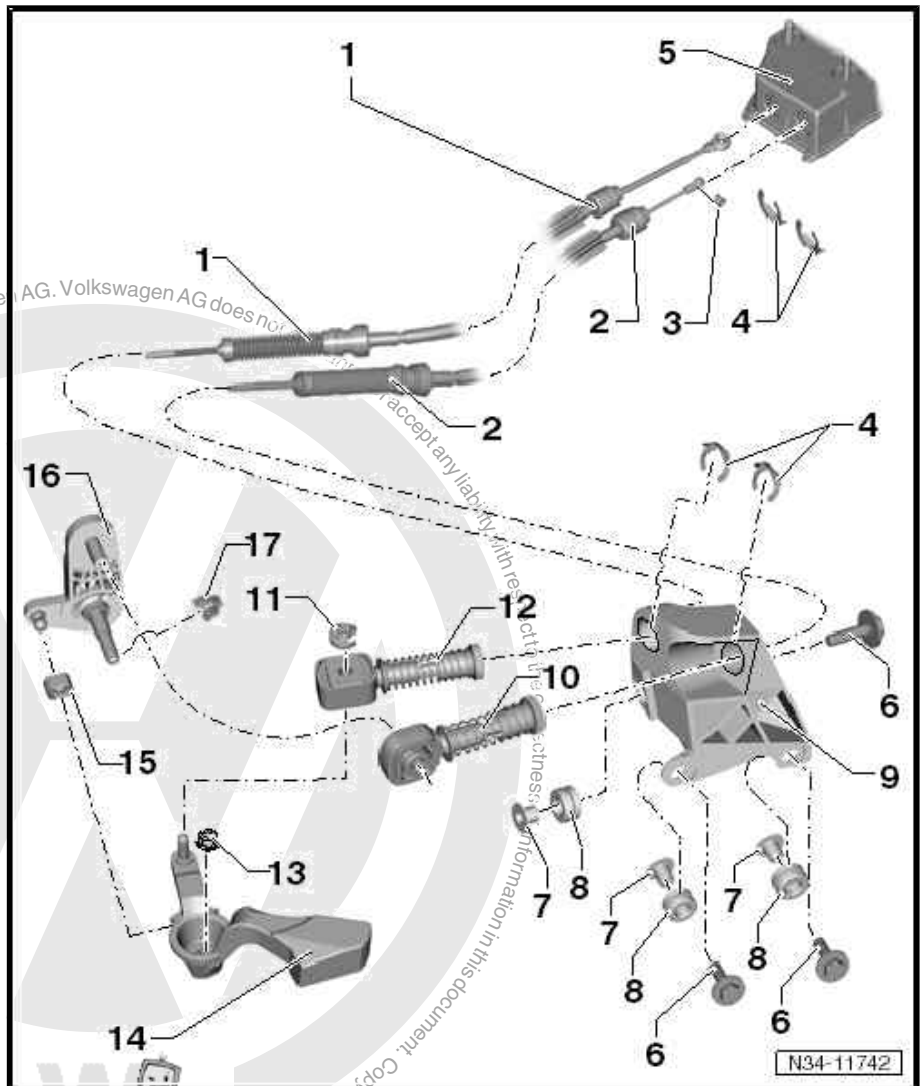

3 - Bush

4 - Securing clip

- Do not damage cables when removing
- Renew after removal
- Fitting position ⇒ [page 76](#)

5 - Selector housing

- Gear lever is "NOT" pushed down to engage reverse gear: selector mechanism can be dismantled (only up! ⇒ 02 14)
- Gear lever "IS" pushed down to engage reverse gear: selector mechanism cannot be dismantled (Polo and up! 03 14 ⇒)



6 - Hexagon bolt

- Qty. 3
- For cable support bracket
- 25 Nm

7 - Spacer

- Qty. 3
- For cable support bracket

8 - Grommet

- Qty. 3
- Cable support bracket mounting on gearbox

9 - Cable support bracket

- Remove from gearbox ⇒ [page 72](#) .
- After installing, adjust selector mechanism ⇒ [page 76](#)

10 - Cable end-piece

- Removing and installing ⇒ [page 73](#)
- After installing, adjust selector mechanism ⇒ [page 76](#)
- For gate selector cable to relay lever
- Remove from relay lever ⇒ [page 75](#)
- Press onto relay lever ⇒ [page 75](#)
- Allocation ⇒ [page 73](#) .

11 - Securing clip

- Renew after removal

12 - Cable end-piece

- Removing and installing ⇒ [page 73](#)
- After installing, adjust selector mechanism ⇒ [page 76](#)
- For gear selector cable to gearbox selector lever
- Allocation ⇒ [page 73](#) .

13 - Hexagon nut

- ⇒ [Item 6 \(page 118\)](#)

14 - Gearbox selector lever

- Can be renewed with the selector mechanism installed
- Grease before installing ⇒ [page 73](#) .
- Fitting position ⇒ [page 74](#)
- Installing ⇒ [page 74](#)
- After installing, adjust selector mechanism ⇒ [page 76](#)

15 - Slide block

- Shoe and relay lever are listed as one replacement part.

16 - Relay lever

- Fitting position ⇒ [page 74](#)
- Grease before installing ⇒ [page 74](#) .
- After installing, adjust selector mechanism ⇒ [page 76](#)
- Remove and install together with cable end-piece ⇒ [page 74](#)

17 - Clip

- Secures relay lever.
- Check for damage

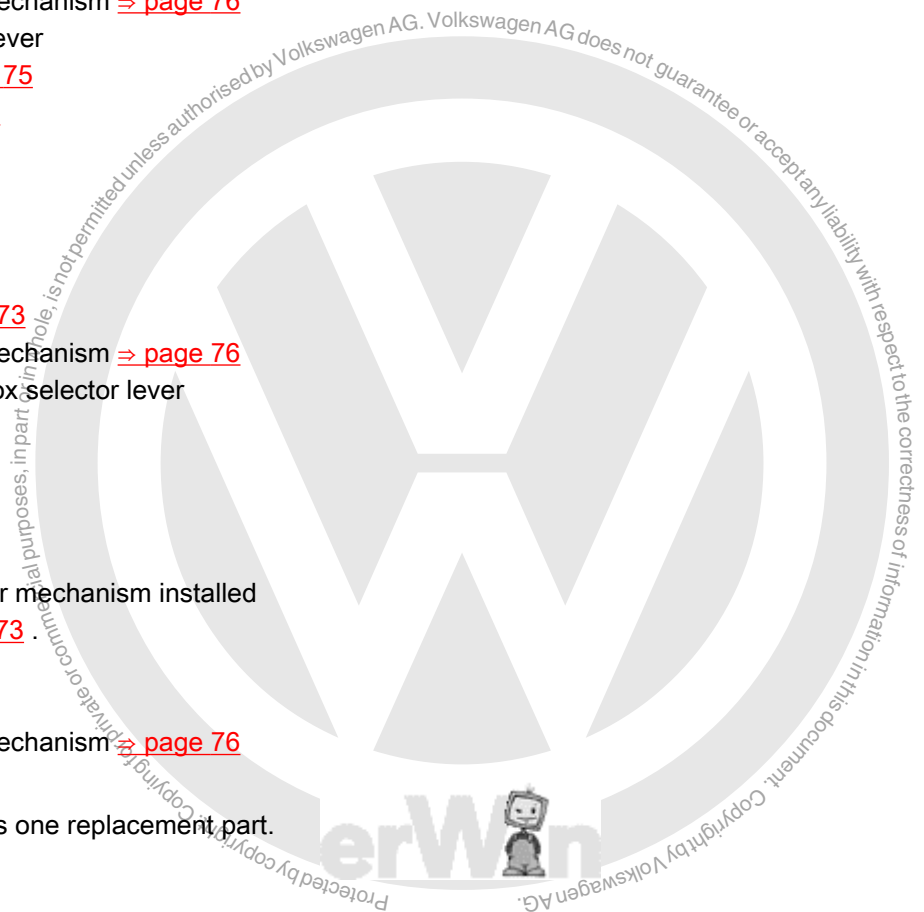



1.6 Removing and installing gear knob

Special tools and workshop equipment required

- ◆ Hose clip pliers - V.A.G 1275 A-



- ◆ Wedges - T10383-

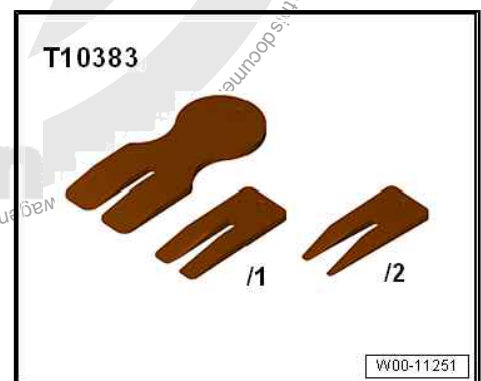

Removing

- Cover centre console in area of gear lever boot with a cloth.

up!

- Using wedge - T10383/1- , carefully lever off gear lever gaiter in rear area from centre console -arrows-.

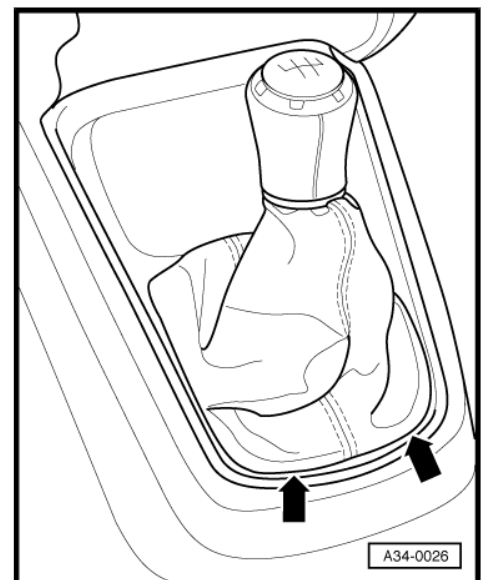



- Lift up gear lever boot slightly in rear area.
- Using a flat-bladed screwdriver, carefully push detents -A- in front area of gear lever boot in direction of -arrow-.
- Remove gear lever boot from centre console.

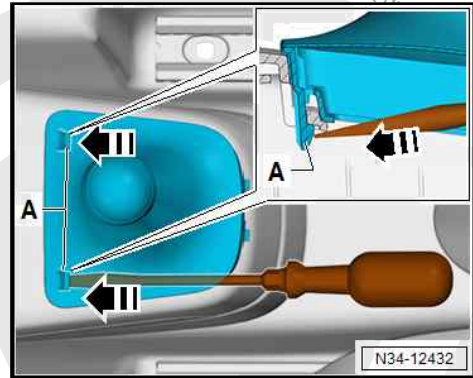

Polo

Carefully insert lever. On some vehicles it might be helpful to begin »at front«.

- Using wedge - T10383- , carefully lever gear lever gaiter off centre console insert -arrows-.
- Alternatively, use removal wedge - 3409- to lever out gear lever gaiter.

Continuation for all

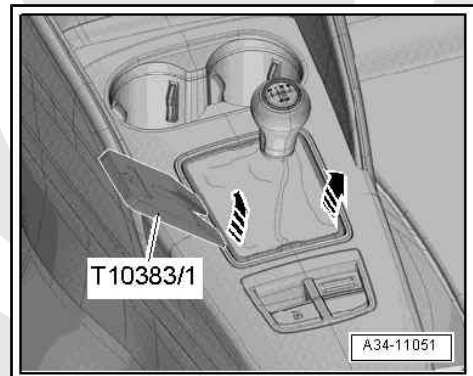

- Pull gear lever gaiter upwards, inside out over gear knob.
- Open clamp -arrow- and pull off gear knob together with gear lever gaiter.

Installing

Install in reverse order of removal, observing the following:

- Press gear knob together with gear lever gaiter onto gear lever as far as stop.
- Secure gear lever knob to gear lever using clamp -arrow-. Use hose clip pliers - V.A.G 1275 A- to do this.

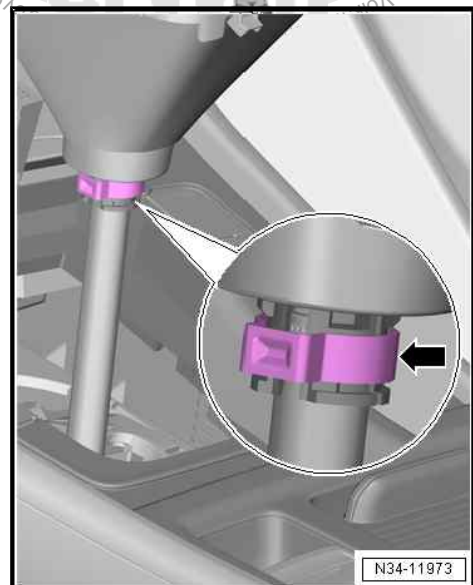



1.7 Emblem identification

Selector mechanism:	Symbol line on gear knob:
1. - Gear lever is "not" pushed down to engage reverse gear	Continuous -arrow-
2. - Gear lever "is" pushed down to engage reverse gear	Interrupted -arrow-

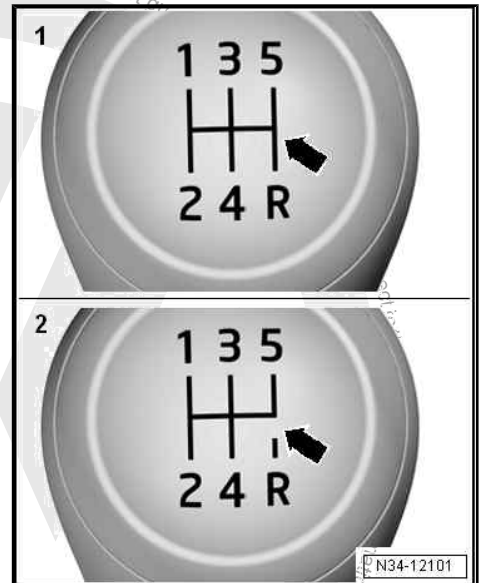

1.8 Removing and installing selector mechanism

Special tools and workshop equipment required

- ◆ Torque wrench - V.A.G 1331-



Removing

- Disconnect battery ⇒ Electrical system; Rep. gr. 27 ; Battery; Disconnecting and connecting battery .
- Remove gear lever gaiter with gear knob and any noise insulation from frame for centre console ⇒ [page 67](#) .

up!

- Remove centre console insert ⇒ General body repairs, interior; Rep. gr. 68 ; Centre console; Removing and installing centre console insert .
- Unbolt back of upper part of centre console ⇒ General body repairs, interior; Rep. gr. 68 ; Centre console; Removing and installing centre console .
- Unbolt lower part of centre console in footwell ⇒ General body repairs, interior; Rep. gr. 68 ; Centre console; Removing and installing centre console .

Polo

- Remove centre console with securing bracket ⇒ General body repairs, interior; Rep. gr. 68 ; Centre console; Assembly overview - centre console .



Continuation for all

- Unscrew nuts -arrows- for selector housing and, if necessary, centre console securing bracket. To do this, carefully raise lower part of centre console.
- Lower selector housing.
- If fitted, remove insulation from selector housing => General body repairs, interior; Rep. gr. 68 ; Centre console; Assembly overview – centre console .
- Remove complete air filter housing if it is located over selector mechanism => Rep. gr. 24 ; Air filter; Removing and installing air filter .
- Pull cable end-piece off gear selector cable and gate selector cable forward to stop in -direction of arrow 1- and then lock in -direction of arrow 2-.

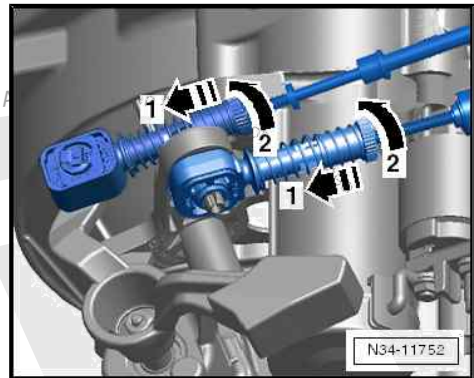
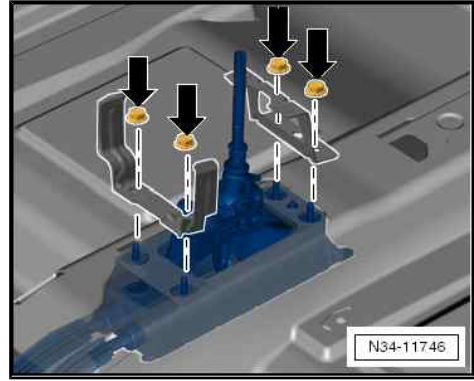

up!

In some equipment versions, the gear selector cable is only accessible from beneath vehicle in -direction of arrow-.

Continuation for all

- Remove securing clips -arrows- for cables from cable support bracket.
- Remove heat shield.
- Swing down gear lever housing and remove with selector cables.

Installing

Install in the reverse order of removal, observing the following.

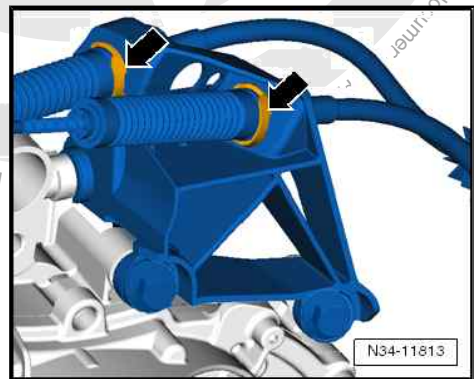
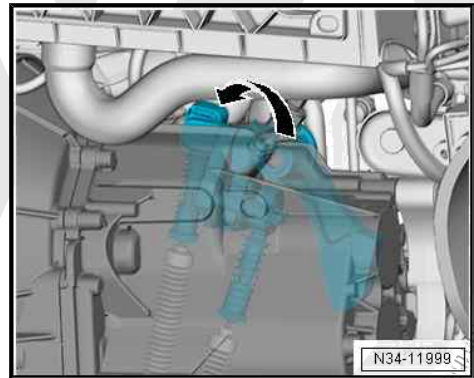



– Route Bowden cables -1- from selector mechanism -2- to gearbox as follows:

- ◆ Cables must be routed parallel to one another as far as cable support bracket on gearbox.
- ◆ Bowden cables must be laid in the intended indentation in heat shield -3-.

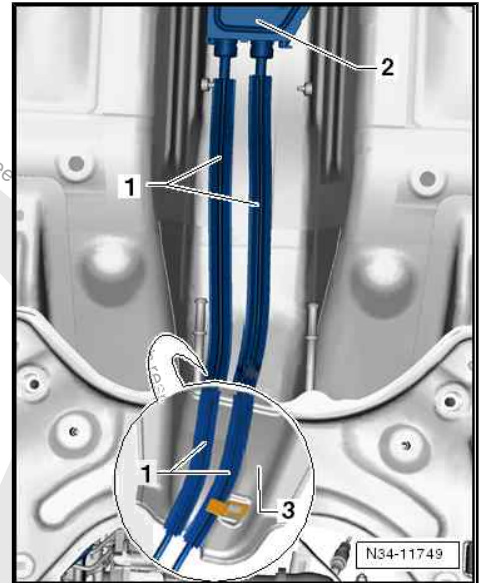

up!

Clip -A- holds cables and heat shield in position (if applicable).

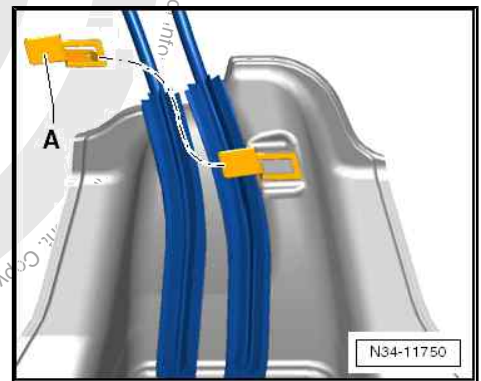



Continuation for all

- Insert cables into cable end-pieces.
- Install securing clips -arrows- for cables to cable support bracket.
- Align selector housing parallel to body.
 - Distance to body must be same on both sides.
 - Adjust selector mechanism ⇒ [page 76](#) .
 - Install centre console and tighten bolts ⇒ General body repairs, interior; Rep. gr. 68 ; Centre console; Removing and installing centre console .
 - Install centre console insert ⇒ General body repairs, interior; Rep. gr. 68 ; Centre console; Removing and installing centre console insert .
 - Install heat shield.
 - Assemble exhaust system free of tension ⇒ Rep. gr. 26 ; Exhaust pipes/silencers; Removing and installing front exhaust pipe .
 - If removed, install complete air filter housing ⇒ Rep. gr. 24 ; Air filter, Removing and installing air filter housing .
 - Connect battery and follow procedure after connecting battery ⇒ Electrical system; Rep. gr. 27 ; Disconnecting and connecting battery .

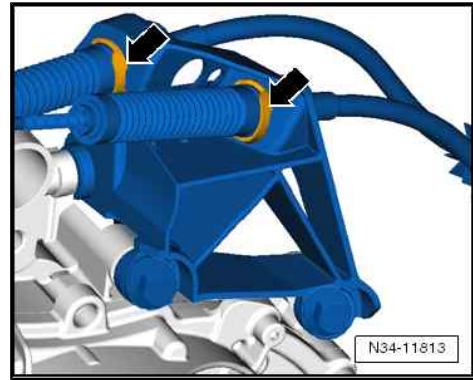

Specified torques

Selector housing to body ⇒ [page 62](#) .

Selector cable support bracket to gearbox ⇒ [page 65](#)

1.9 Repairing selector mechanism

Remove cable support bracket from gearbox.

Bolts -arrow A- are accessible from engine compartment.

Bolt -arrow B- is accessible from beneath vehicle.

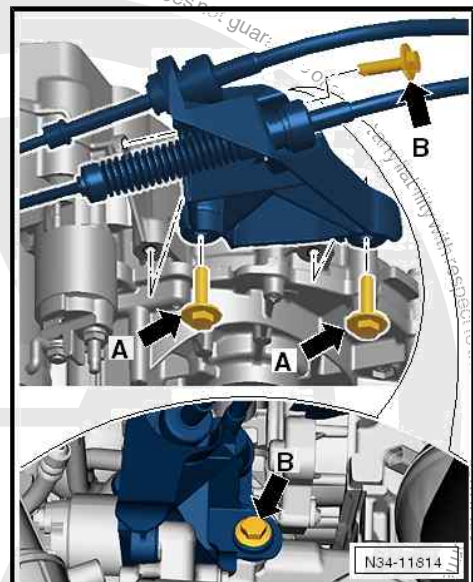



Removing and installing gear selector cable and relay lever

- Remove securing clip -1- for gear selector cable -2- from gearbox selector lever and pull cable end-piece for gear selector cable off pin.
- Remove cable end-piece for relay lever -3- together with relay lever ⇒ [page 74](#) .

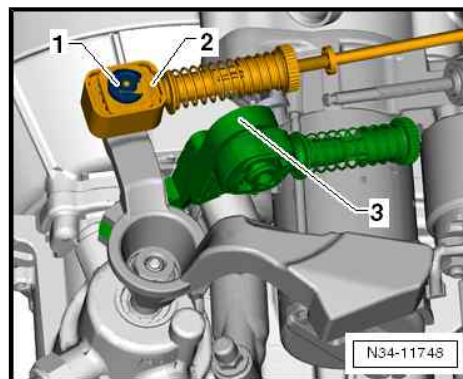

Allocation of cable end-pieces

The holes in the cable end-pieces have different diameters.

Cable end-piece for	Dimension "a"
1. - Gear selector cable to gearbox selector lever	8.5 mm
2. - Gate selector cable to relay lever	10 mm

The holes in the cable end-pieces have different diameters.

- Spread a small amount of grease on pin of gearbox selector lever.

Allocate grease using ⇒ Electronic parts catalogue (ETKA) .

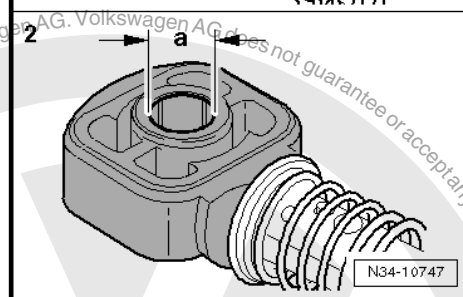
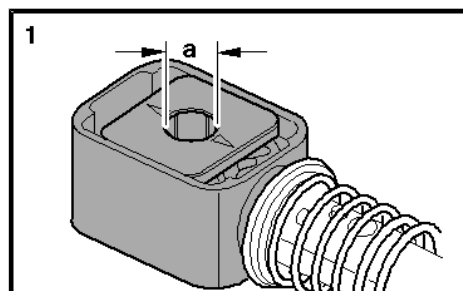

- Renew securing clip -1- for gear selector cable -2- each time after removing.
- Install relay lever -3- and cable end-piece together.

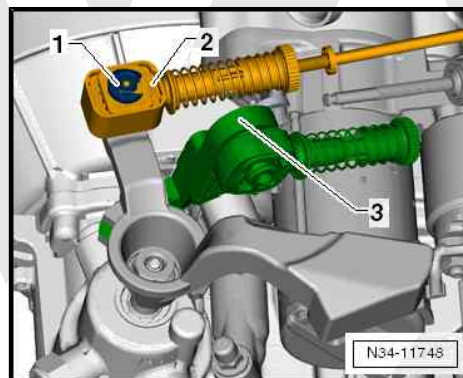

Apply grease to gearbox selector lever

- Apply grease to guide rail -B- of gearbox selector lever in which the relay lever engages, being especially careful when doing so.
- Allocate grease using ⇒ Electronic parts catalogue (ETKA) .

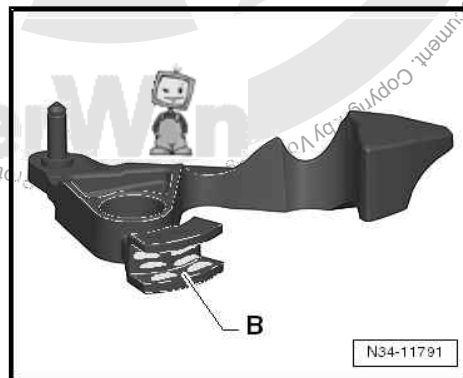



Install gearbox selector lever

- When fitting the gearbox selector lever, ensure that the gap -arrow A- is aligned with the master spline -arrow B-.



Note

The picture of the gearbox selector lever may differ from the original part.

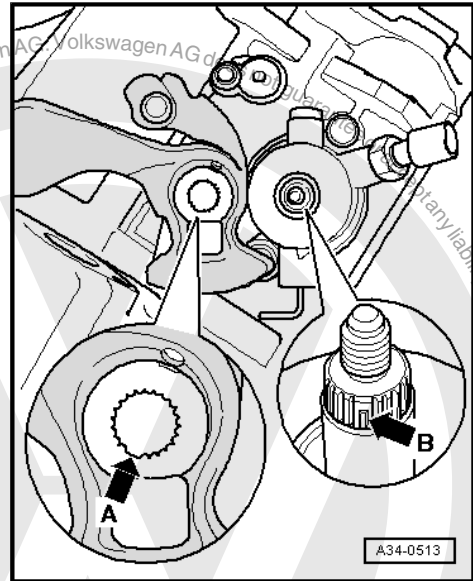

Installation position of gearbox selector lever/relay lever

- 1 - Gearbox selector lever
- 2 - Relay lever engages in guide rail of gearbox selector lever via shoe -arrow-.

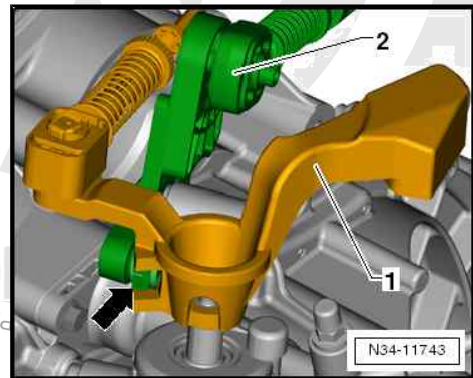

Greasing the relay lever.

- Grease shaft -A- of relay lever all over with great care -arrows-: amount of grease: 0.2 g.
- Allocate grease using => Electronic parts catalogue (ETKA) .



Note

The picture of the relay lever may differ from the original part.

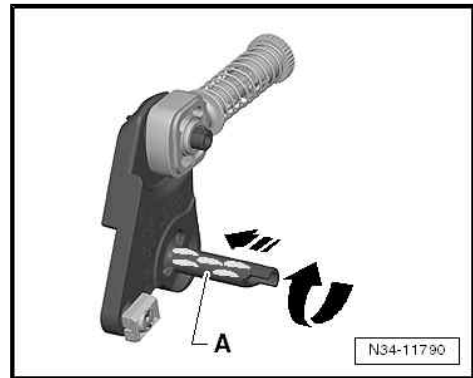

Removing and installing relay lever with cable end-piece

- To remove relay lever, first detach cable end-piece from gate selector cable.

This will avoid damage to the gate selector cable.

- Relay lever must be removed before removing cable end-piece => [page 75](#) .
- Pull locking mechanism forward to stop in -direction of arrow 1-, and then lock it by turning to left in -direction of arrow 2-.
- Then push relay lever forwards (-direction of arrow 3-).

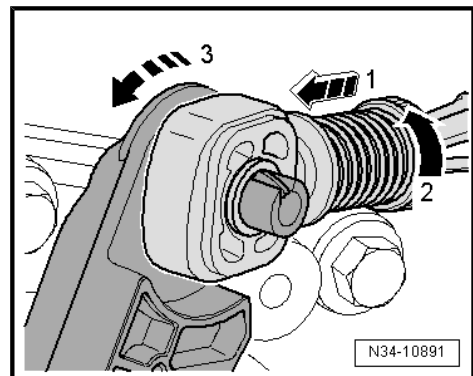



- Pull off clip -arrow 1- and remove relay lever together with cable end-piece.

Cable end-piece must be located behind catch -arrow 2-.

i Note

- ◆ Lubricate bearing positions and sliding surfaces.
- ◆ Allocate grease using ⇒ *Electronic parts catalogue (ETKA)*.
- Press cable end-piece onto relay lever ⇒ [page 75](#).
- Install relay lever together with cable end-piece to stop.
- Clip -arrow 1- secures relay lever.
- Ensure proper engagement of clip.
- Cable end-piece must be located behind catch -arrow 2-.



Levering cable end-piece for gate selector cable off relay lever

- Relay lever has been removed.
- Insert a flat-blade screwdriver -A- between bush -B- and relay lever.

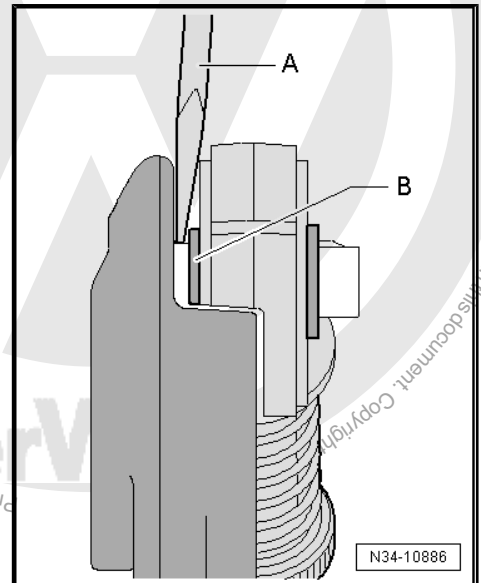

Press cable end-pieces onto relay lever

- Relay lever has been removed.
- Cable end-piece may be pressed only onto bush -arrow-.
- Cable end-piece must move freely on relay lever.
- It must be located behind catch -arrow 2- ⇒ [page 74](#).

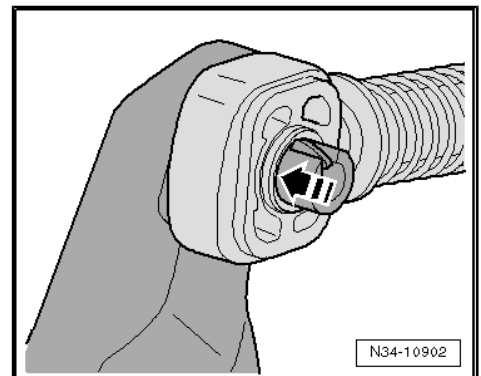



Installation position of securing clips -1- and -2-.

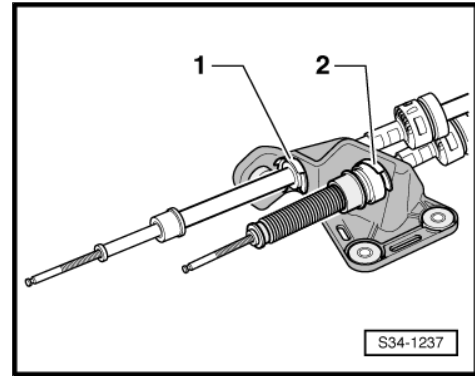

1.10 Adjusting selector mechanism

Special tools and workshop equipment required

- ◆ Pin - T10027 A-

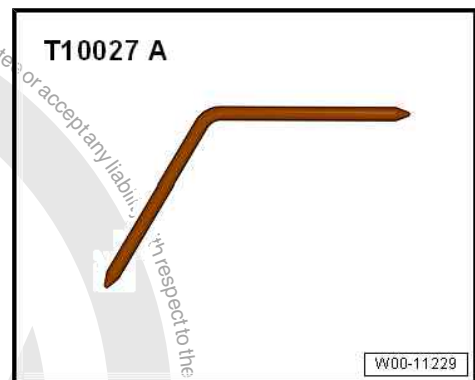

Prerequisites for adjustment

- Moving parts of selector mechanism and elements transferring force must be in proper condition.
- Selector mechanism must move freely.
- Gearbox, clutch and clutch mechanism must be in proper condition.
- Gearbox must be in neutral.
- Remove air filter housing if it prevents access to gear selector lever and cable end-pieces of gear selector cable and gate selector cable ⇒ Rep. gr. 24 ; Air filter; Removing and installing air filter housing
- Check neutral position by pushing down gear selector lever in -direction of arrow-.
- Gearbox selector lever returns to initial position on its own.

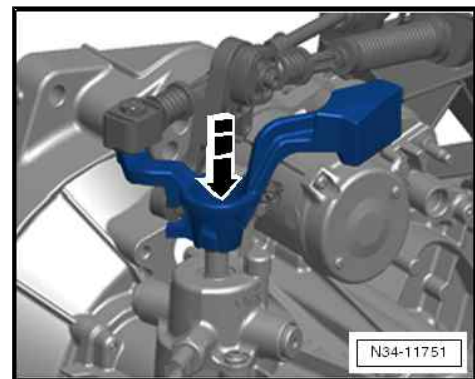



Open cable end-pieces on gearbox:

- Pull cable end-piece off gear selector cable and gate selector cable forward to stop in -direction of arrow 1- and then lock in -direction of arrow 2-.
- It must be possible to push the cables into the cable end-piece.

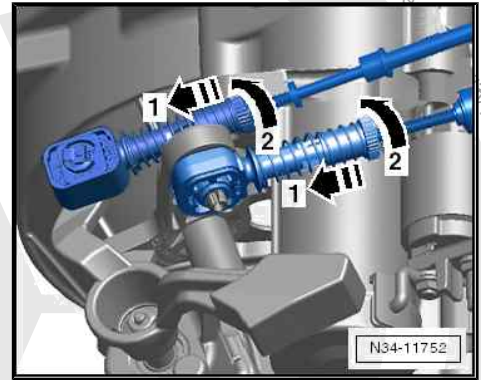

up!

- It must be possible to push the cables into the cable end-piece.

Depending on equipment, the gear selector cable may be accessible only from beneath vehicle in -direction of arrow-.

Continuation for all

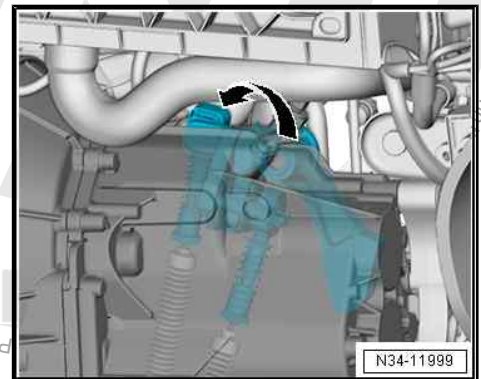

Move gear lever in correct position for adjustment:

- Remove gaiter and, if necessary, noise insulation from centre console => [page 67](#) .
- Move gear lever to neutral position, press it to left and hold in this position.
- Push locking pin - T10027 A- through hole -A- into hole -B-.

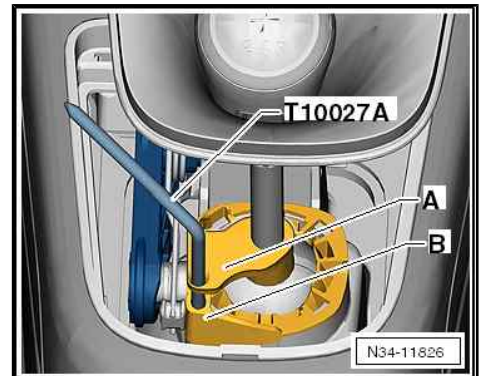

- Gate selector cable and gear selector cable -B- are located stress-free in cable end-pieces -A-.
- Now turn locking mechanism on gear selector cable and gate selector cable end pieces as far as stop in -direction of arrow 1-.

The spring presses the locking mechanism into original position -direction of arrow 2-.

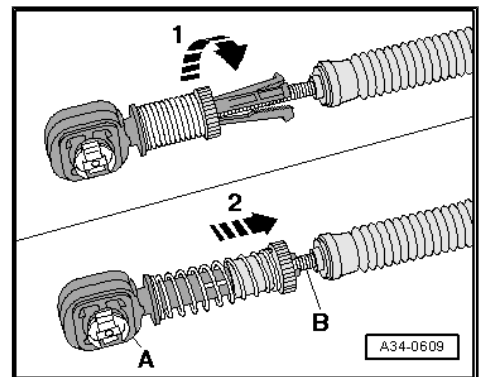



- Pull locking pin out of holes -A- and -B-.
- Install gaiter and, if present, noise insulation ⇒ [page 67](#) .
- Check selector shaft can move freely.
- Check selector mechanism ⇒ [page 78](#) .
- If removed, install complete air filter housing ⇒ Rep. gr. 24 ; Air filter; Removing and installing air filter housing .

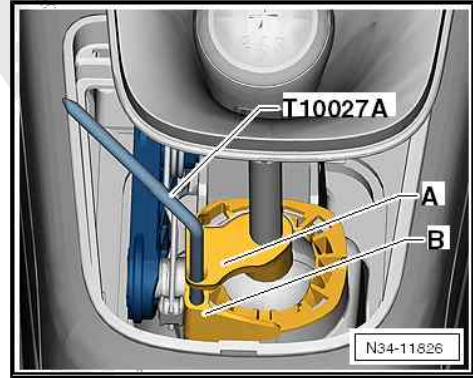

1.11 Checking selector mechanism

- With gearbox in neutral, gear lever must be in gear lever gate for 3rd and 4th gear.
- Operate clutch.
- Select all gears several times.
- If gear lever needs to be “pushed down” to engage reverse gear, pay particular attention to operation of reverse gear lock.
- If the difficulty in engaging a gear persists after repeated attempts, repeat adjustment procedure of selector mechanism ⇒ [page 76](#) .

1.12 Dismantling and assembling selector mechanism

⇒ [“1.12.1 Dismantling and assembling selector mechanism, - gear lever is NOT pushed down to engage reverse gear”, page 78](#)

1.12.1 Dismantling and assembling selector mechanism, - gear lever is NOT “pushed down” to engage reverse gear

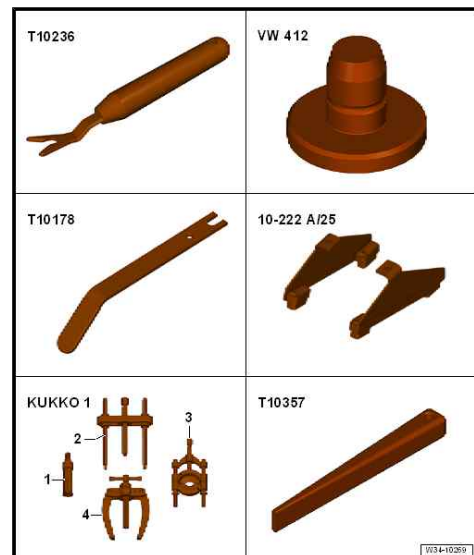

Special tools and workshop equipment required

- ◆ Release tool - T10236-
- ◆ Press tool - VW 412-
- ◆ Assembly tool - T10178-
- ◆ Adapter - 10 - 222 A /25-
- ◆ 2 = counter support e.g. from -Kukko- , type 16



◆ Wedge - T10357-

Dismantling

- Remove selector mechanism ⇒ [page 69](#) .
- Bend open tabs -arrows- of base plate using a screwdriver (here only tabs on left side of base plate are marked).
- Remove base plate.
- Remove gasket ⇒ [Item 15 \(page 63\)](#) from selector housing.
- Remove gear selector cable and gate selector cable from selector housing ⇒ [page 82](#) .
- Pull clip -A- out of bearing shaft for gate selector lever.

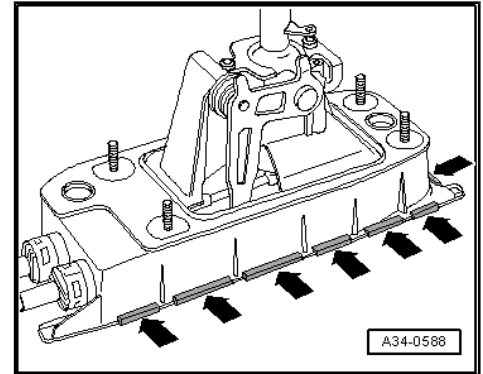

- Use screwdriver to press down catch -B- of bearing bush for gate selector lever. Break off catch if necessary.
- Push bearing bush for gate selector lever out of selector housing.

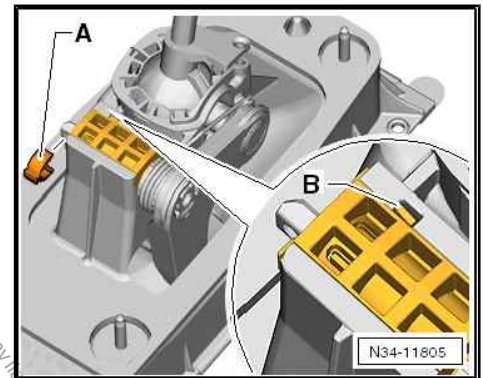

- Use screwdriver to press catches -arrows- of ball socket towards bearing ball of gear lever guide. Break off catches if necessary.

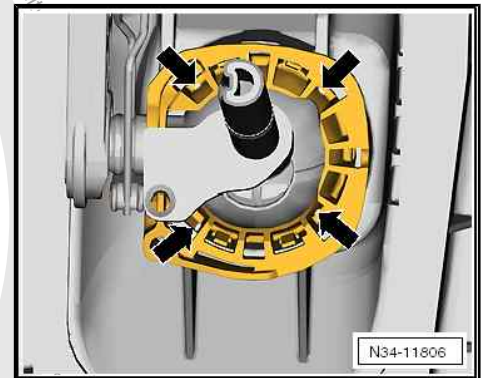

- Lever ball socket and gear lever out of selector housing -arrow A-.
- Then press ball socket off bearing ball of gear lever guide -arrow B- and remove gear lever with gate selector lever.

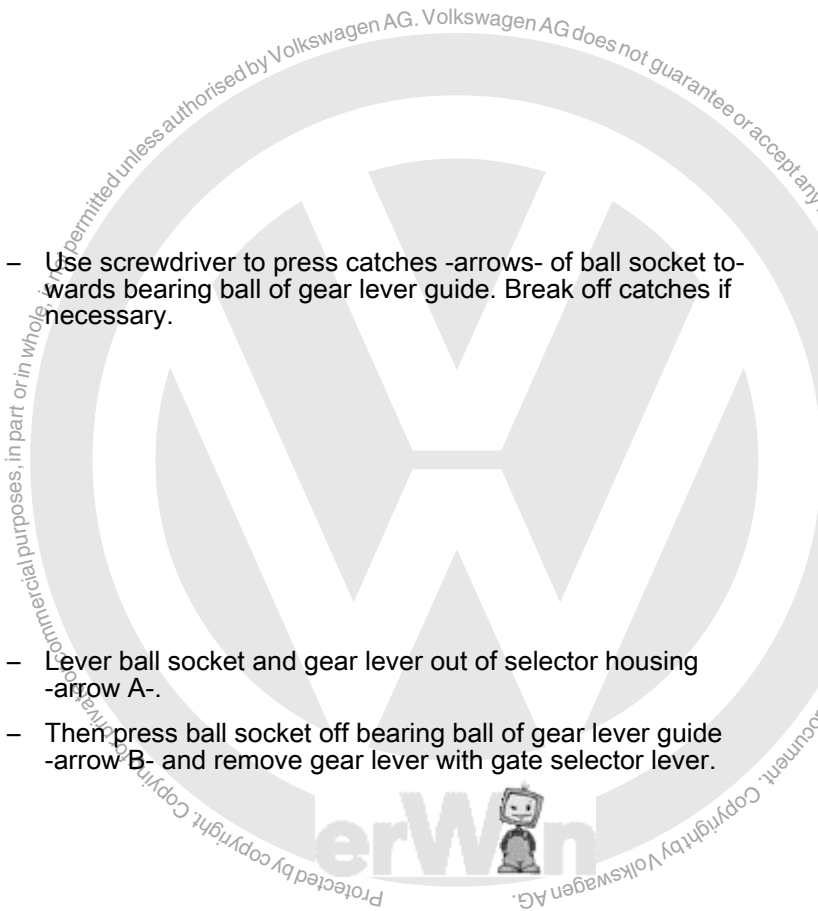
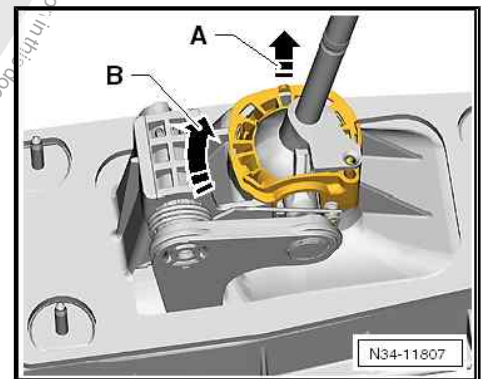



- Clamp gear lever with gate selector lever in a vice with protective jaws.
- Push gate selector lever off gear lever in -direction of arrow-.



Caution

The compression spring -A- may snap off the gate selector lever in an uncontrolled manner.

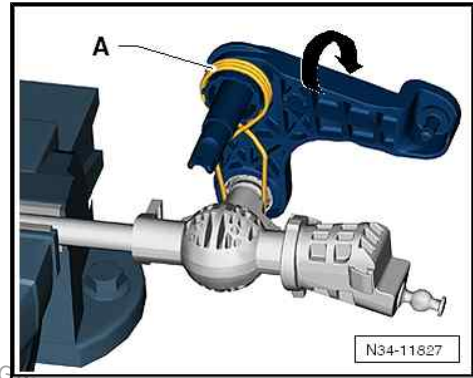

Assembling

- Fit bearing bush onto gear lever.

Installation position of bearing bush

Slots around bearing bush -arrow- are pointing towards gear lever.

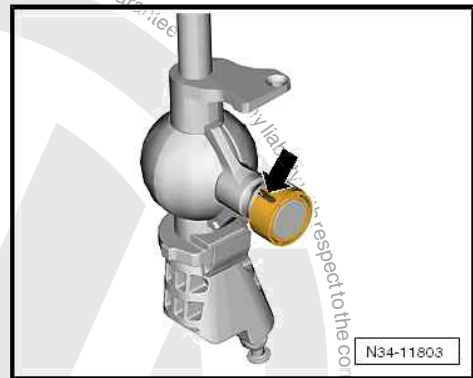

- Install gate selector lever together with compression spring to gear lever:
 - Ends -A- and -B- must point in same direction.
- Fit end -A- of compression spring into guide from above (in direction of gear lever)
- Carefully pull end -B- of compression spring down and fit into guide (in direction of gear lever).
- Push gate selector lever -arrow- onto gear lever.

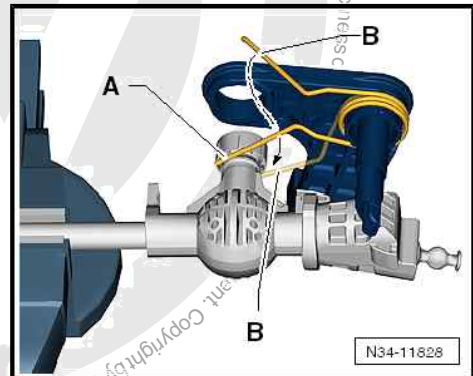

Caution

The compression spring A must not snap off the gate selector lever in an uncontrolled manner.

- If removed, push ball sockets onto gear lever.

Installation position of ball sockets

Pins -A- are located in holes -B-.

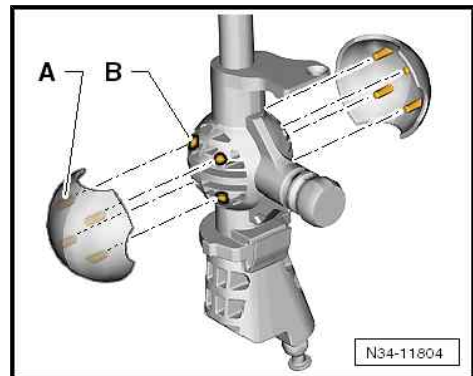



- Fit new ball socket -A- onto gear lever.
- Grease ball socket -A- and ball sockets of gear lever.
- Rotate ball socket in -direction of arrow-.
- Seat of journal -1- is in recess -2- of ball socket -A-.
- Damping -4- is fitted between ends of spring -3-.

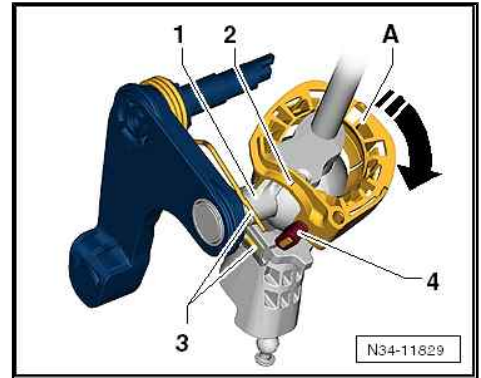

- Push ball socket -A- together with gear lever and gate selector lever into selector housing. Note correct installation position => [page 81](#) .
- All 4 retaining lugs must engage.
- Slide in bearing bush -B- for gate selector lever.

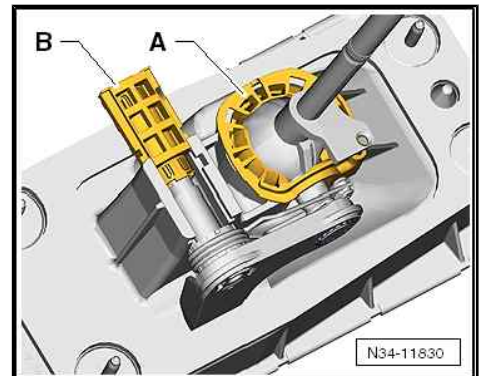

Installation position of bearing bush

Catch -B- must engage in recess in selector housing.

- Secure gate selector lever with clip -A-.
- Install gear selector cable and gate selector cable => [page 62](#) and => [page 65](#) .

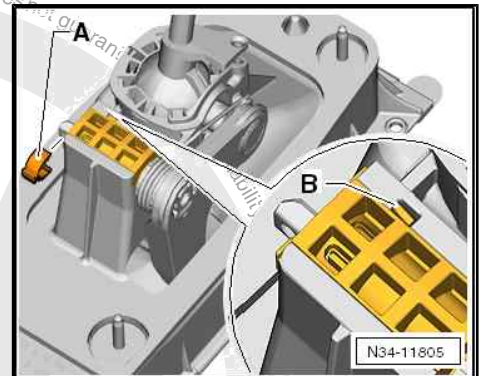

Installing base plate to selector housing

- Fit new seal to base plate.

Caution

Risk of damage to selector housing and floor plate.

Only lightly tighten selector housing.

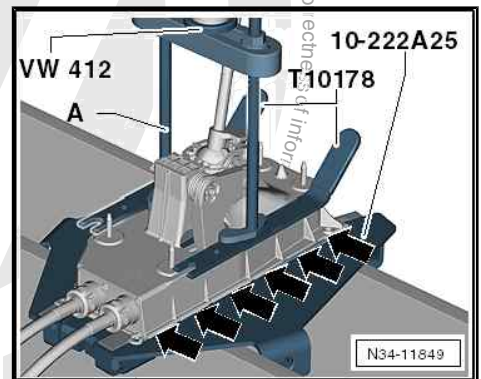

- Secure base plate by bending down tabs -arrows- around circumference of base plate (here only tabs on left side of base plate are marked).
- Tabs can be bent down using wedge -T10357- .
- A- = counter support e.g. from -Kukko- , type 16
- Bond new gasket => [Item 15 \(page 63\)](#) to selector housing.
- Install selector mechanism => [page 69](#) .
- Adjust selector mechanism => [page 76](#) .



1.13 Removing and installing selector cable

⇒ **“1.13.1 Removing and installing selector cable, - gear lever is NOT pushed down to engage reverse gear”, page 82**

1.13.1 Removing and installing selector cable, - gear lever is NOT “pushed down” to engage reverse gear

Special tools and workshop equipment required

- ◆ Release tool - T10236-

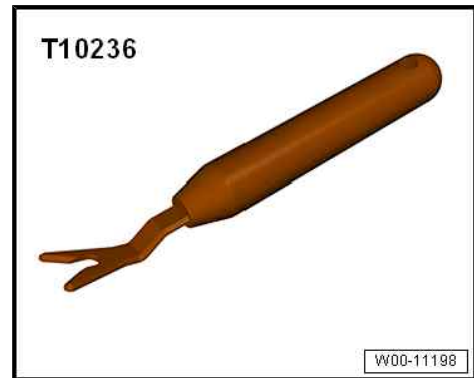

Removing

- Remove selector mechanism ⇒ [page 69](#) .
- Bend open tabs -arrows- of base plate using a screwdriver (here only tabs on left side of base plate are marked).
- Remove base plate.
- Remove seal.

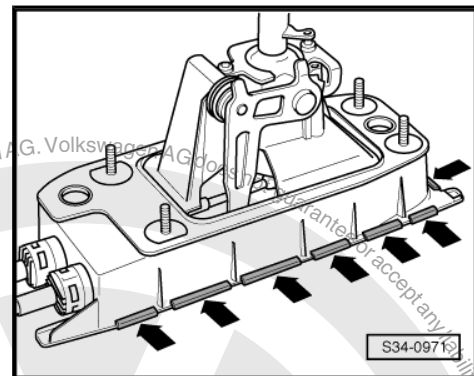

- Push gear selector cable -1- and gate selector cable -4- off gear lever and selector lever, e.g. using release tool - T10236- or a screwdriver.
- Pull off securing clips -2- and -3-.
- Pull gear selector cable and gate selector cable from selector housing.

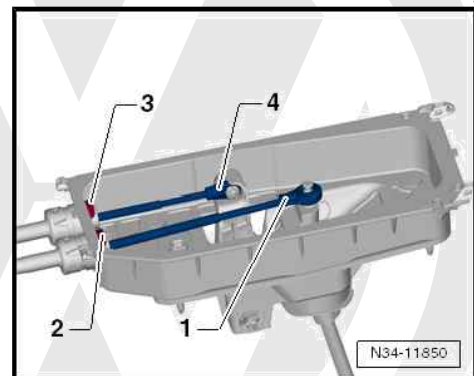



Installing

Install in reverse order of removal, observing the following:

- Secure gear selector cable and gate selector cable to selector housing using securing clips -2- and -3-.
- Push gear selector cable -1- onto gear lever and gate selector cable -4- onto gate change lever in selector housing.

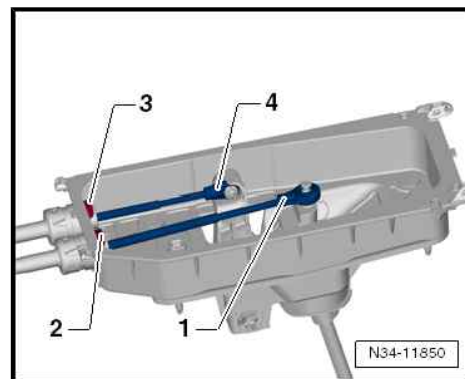

- Secure base plate to selector housing by pressing down tabs -arrows- ⇒ [page 81](#) .
- Install selector mechanism ⇒ [page 69](#) .
- Adjust selector mechanism ⇒ [page 76](#) .

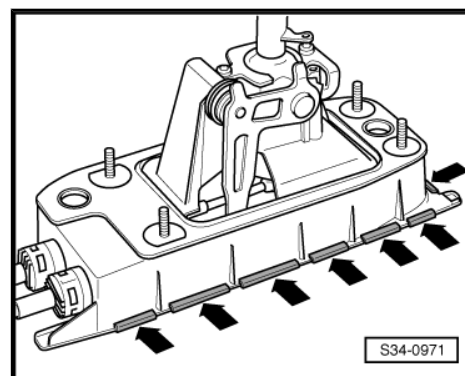

1.14 Renewing selector shaft seal

Special tools and workshop equipment required

- ◆ Removal tool - T20143/1-

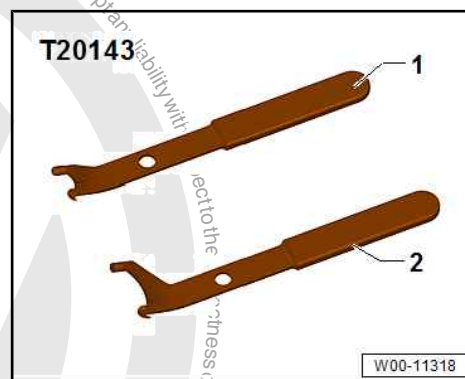

- ◆ Tube - VW 423-

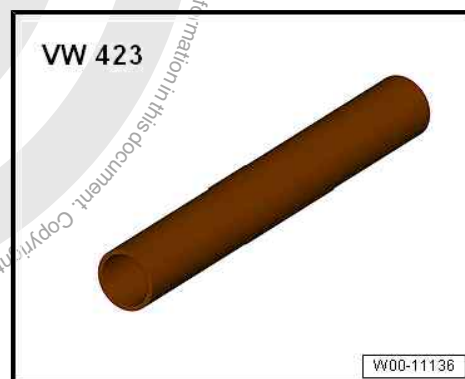

- ◆ Sealing grease
- ◆ Allocate grease using ⇒ Electronic parts catalogue (ETKA) .



- Remove air filter housing completely if it is located above selector mechanism => Rep. gr. 24 ; Air filter; Removing and installing air filter housing .
- Remove battery and battery tray => Electrical system; Rep. gr. 27 ; Battery; Removing and installing battery .
- Remove securing clip -1- for gear selector cable -2- from gearbox selector lever.
- Pull gear selector cable off pin.
- Remove relay lever -3- together with cable end-piece => [page 74](#) .
- Remove gearbox selector lever by unscrewing nut -4- .

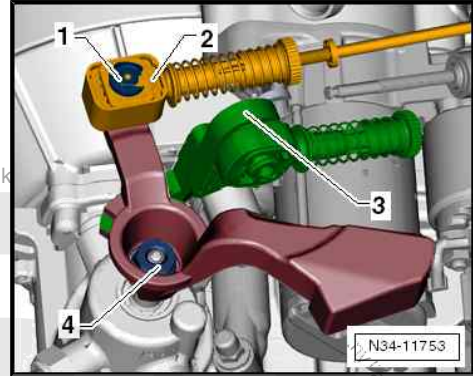

- Lever out seal with oil seal extractor lever - T20143/1- .

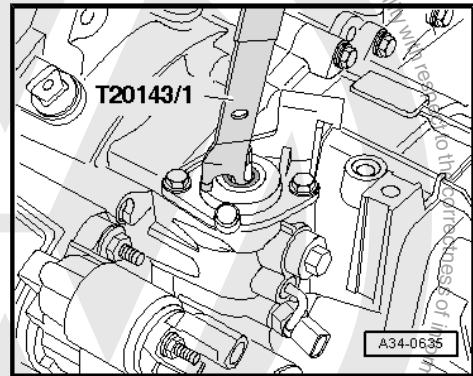

- Half-fill space between sealing lip and dust lip -arrow- with sealing grease .

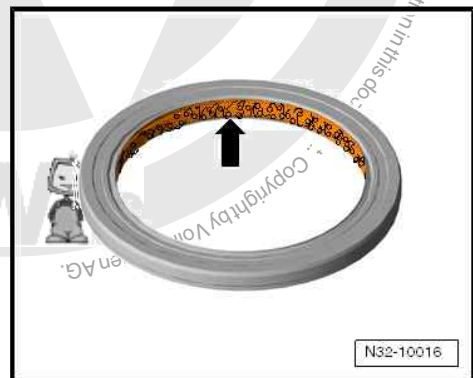

- Drive seal in with tube - VW 423- onto stop.

Perform further installation in reverse order, paying attention to the following:

- Attach gearbox selector lever to gearbox selector shaft => [page 65](#) .
- Adjust selector mechanism => [page 76](#) .
- Tighten hexagon nut to specified torque => [Item 13 \(page 66\)](#) .
- Install battery => Electrical system; Rep. gr. 27 ; Battery; Removing and installing battery .
- If removed, install complete air filter housing => Rep. gr. 24 ; Air filter; Removing and installing air filter housing .

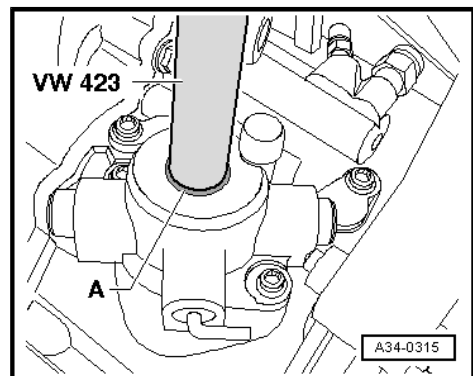



2 Removing and installing gearbox

⇒ ["2.1 Specified torques for gearbox", page 85](#)

⇒ ["2.2 Removing gearbox", page 85](#)

⇒ ["2.3 Installing gearbox", page 101](#)

2.1 Specified torques for gearbox

Item	Bolt	Quantity	Nm
1	M12 × 60	3	80 • With insert tool T10509: »65 Nm«.
2	M12 × 70	2	80
3	M10 × 55	3	40
4	For starter only	2	⇒ Electrical system; Rep. gr. 27 ; Starter; Assembly overview - starter

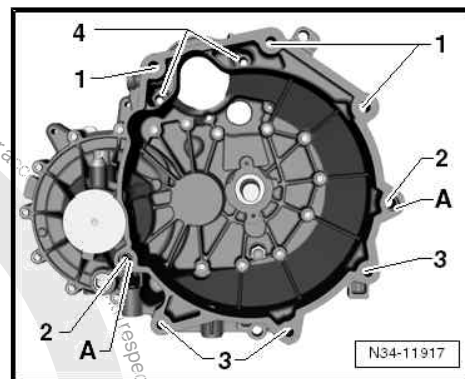

Item -A- for dowel sleeves for centring

2.2 Removing gearbox

⇒ ["2.2.1 Removing gearbox, up!", page 85](#)

⇒ ["2.2.2 Removing gearbox, Polo", page 93](#)

2.2.1 Removing gearbox, up!



Special tools and workshop equipment required

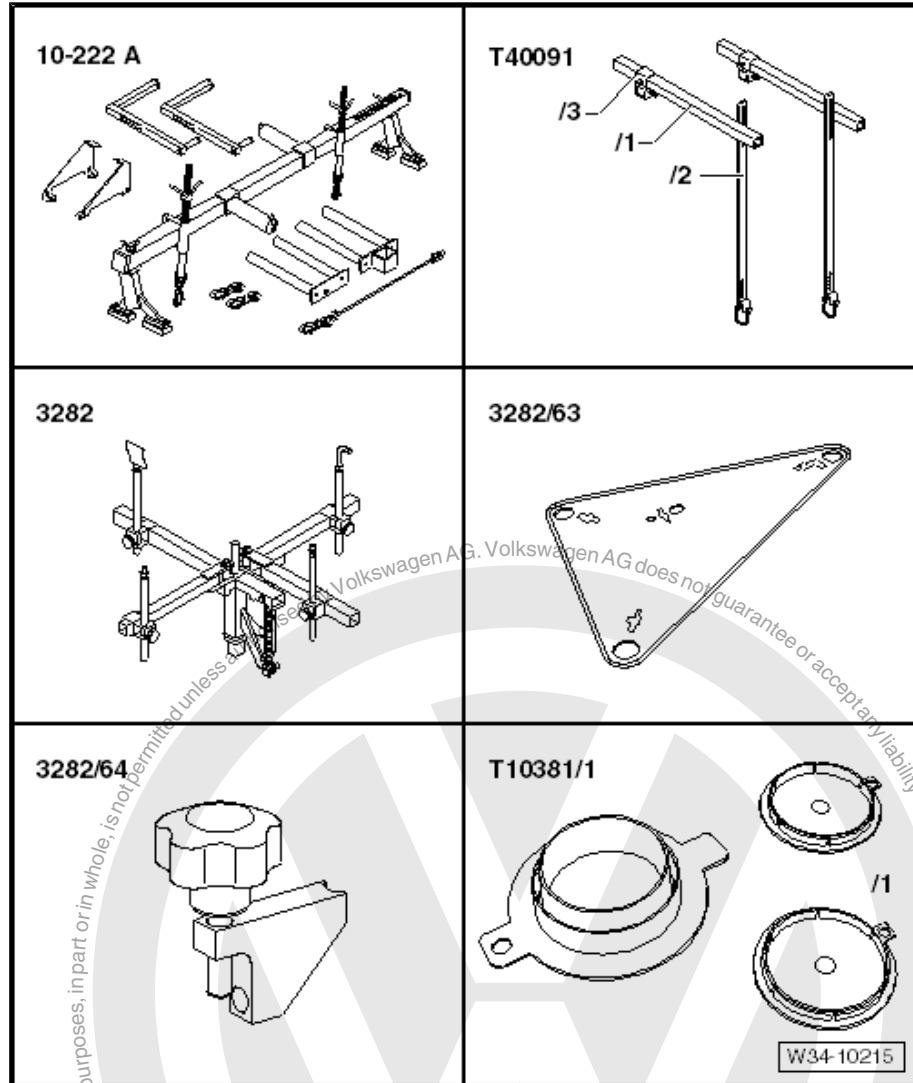

- ◆ Support - 10 - 222 A-
- ◆ Adapter - 10 - 222 A /31-1-
- ◆ Adapter - 10 - 222 A /31-2-
- ◆ Support - 10 - 222 A /31-3-
- ◆ Adapter - 10 - 222 A /31-5-
- ◆ Square tube - T40091/1-
- ◆ Joints - T40091/3-
- ◆ Gearbox support - 3282-
- ◆ Adjustment plate - 3282/63-
- ◆ Adapter - 3282/64-
- ◆ Support elements for gearbox (determine when setting adjustment plate on gearbox support)
- ◆ Sealing cap - T10381/1-

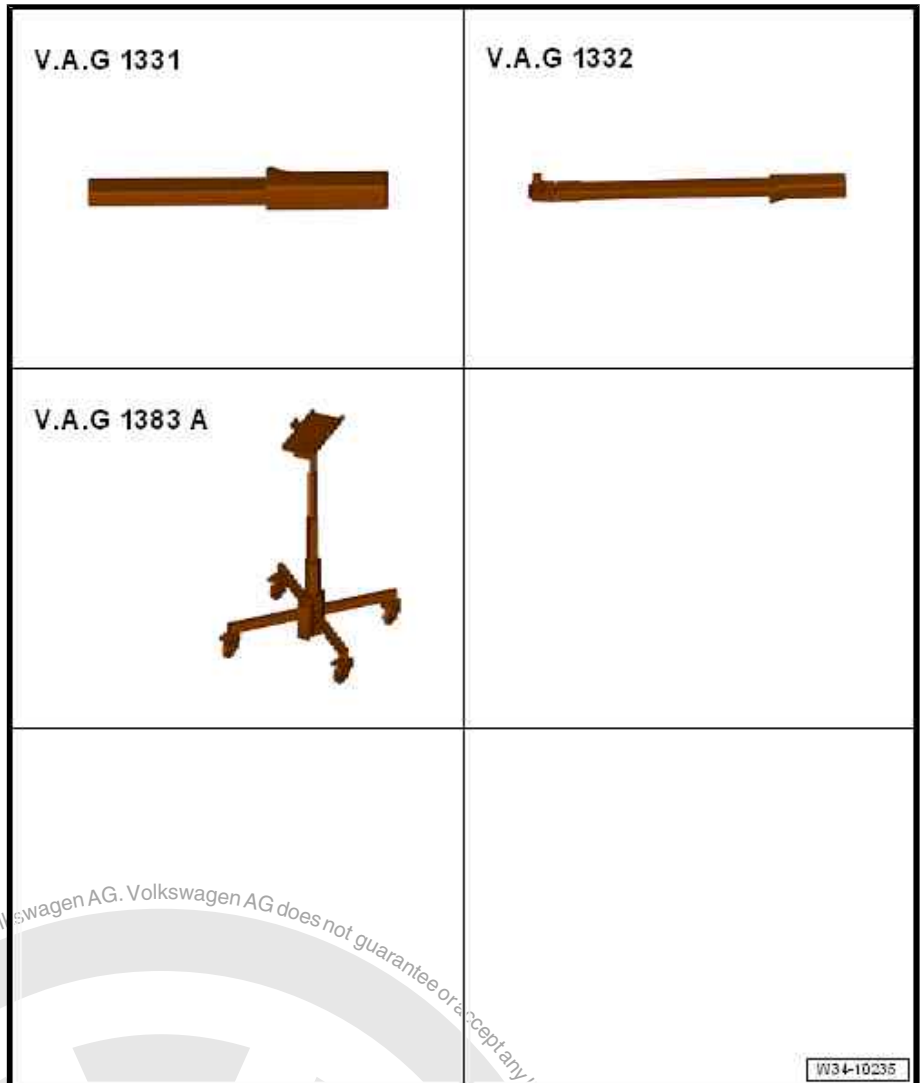

W34-10235



W00-11581

- ◆ Torque wrench - V.A.G 1331-
- ◆ Torque wrench - V.A.G 1332-
- ◆ Engine and gearbox jack - V.A.G 1383 A-
- ◆ Or engine and gearbox jack - VAS 6931-
- ◆ Insert tool - T10509-
- ◆ Grease for splines
- ◆ Allocate grease using ⇒ Electronic parts catalogue (ETKA) .



- ◆ Allocate grease using ⇒ Electronic parts catalogue (ETKA) .
- If support bracket - 10 - 222 A- does not yet have hole marked with -arrow-, then hole must subsequently be drilled into support bracket.
- Dimension -a- = 225 mm.
- Hole diam. = 12.5 mm.
- Disconnect battery ⇒ Electrical system; Rep. gr. 27 ; Battery; Disconnecting and connecting battery .
- Remove engine cover and air filter ⇒ Rep. gr. 24 ; Air filter; Removing and installing air filter housing .
- Remove battery and battery tray ⇒ Electrical system; Rep. gr. 27 ; Battery; Removing and installing battery tray .
- Remove securing clip -1- for gear selector cable -2- from gearbox selector lever.
- Pull gear selector cable off pin.
- Remove relay lever -3- together with cable end-piece ⇒ [page 74](#) .
- Remove gearbox selector lever by unscrewing nut -4-.

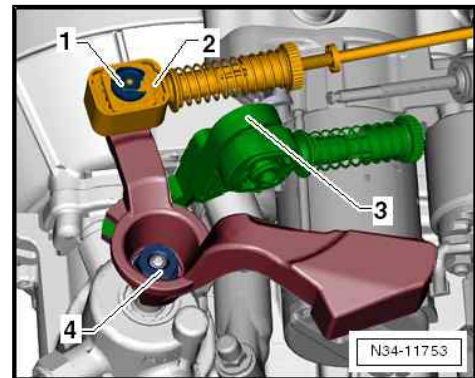
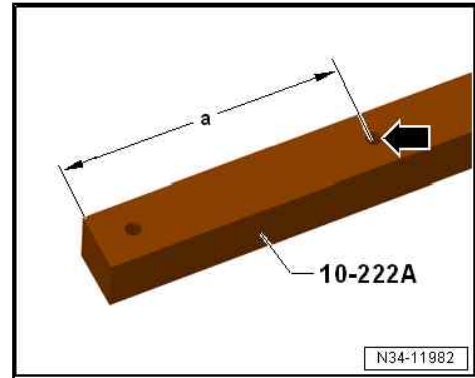

- Remove cable support bracket from gearbox.
- Bolts -arrow A- are accessible from engine compartment.
- Bolt -arrow B- is accessible from beneath vehicle.
- Tie up gear selector cable and gate selector cable.
- Remove starter ⇒ Electrical system; Rep. gr. 27 ; Starter; Assembly overview - starter .

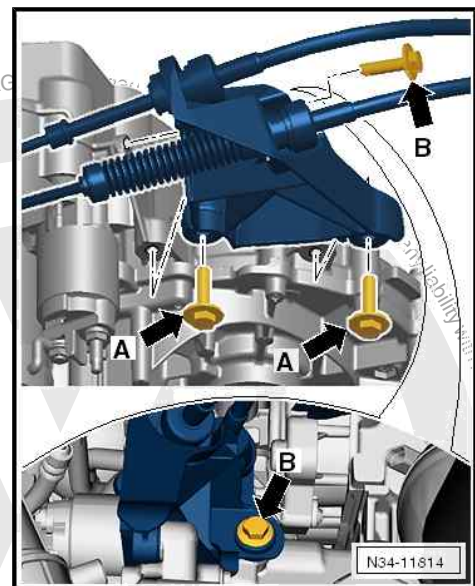

- Remove clutch slave cylinder -arrows-, lay to side and secure. Do not disconnect pipes.



Caution
Do not operate clutch pedal any more.

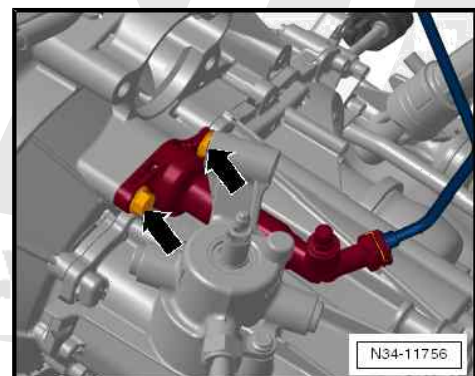



- Remove upper engine/gearbox securing bolts -arrows A- and -arrows B-.
- Loosen bolts -arrows A- if necessary using insert tool, 18 mm - T10509- .
- Install support bracket as follows:

Required material:

- ◆ Adapter - 10 - 222 A /31-1-
- ◆ Adapter - 10 - 222 A /31-2-
- ◆ Connector - T40091/3-
- ◆ Square tube - T40091/1-
- ◆ Support - 10 - 222 A /31-3-
- ◆ Adapter - 10 - 222 A /31-5-

Adapter - 10 - 222 A /31-1- and adapter - 10 - 222 A /31-2- are placed onto suspension strut supports underneath plenum chamber cover.

Therefore, remove following components:

- ◆ Wiper arms ⇒ Electrical system; Rep. gr. 92 ; Windscreen wiper system; Removing and installing wiper arms .
- ◆ Plenum chamber cover ⇒ General body repairs, exterior; Rep. gr. 50 ; Bulkhead; Removing and installing plenum chamber cover
- Fit adapter - 10 - 222 A /31-1- and adapter - 10 - 222 A /31-2- onto suspension strut supports.

Angled pieces of adapters -arrow- point towards engine compartment.

- If fitted, pull bonnet seal off lock carrier.
 - Position support - 10 - 222 A /31-5- above bonnet catch.
- Correct position is between 2 lugs -arrow-.

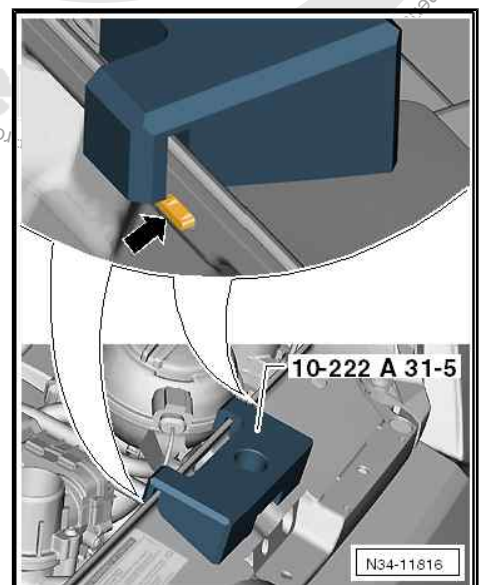
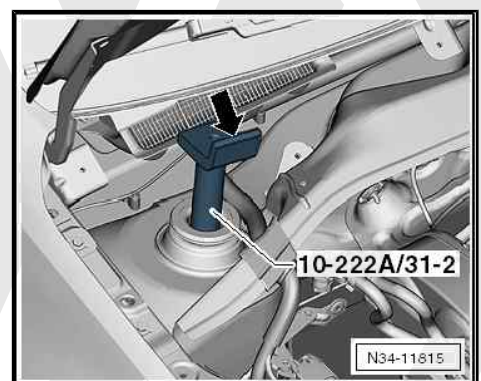
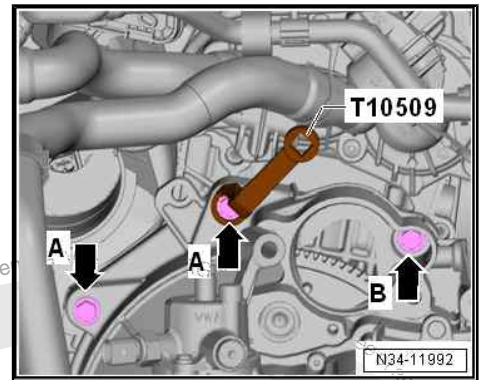



- Slide connector - T40091/3- onto support bracket - 10-222 A- .
- Bolt support bracket - 10-222 A- to adapter - 10- 222 A /31-1- and to adapter - 10 - 222 A /31-2- .
- Attach square tube - T40091/1- to support bracket - 10-222 A- .
- Fit square tube on support - 10 - 222 A /31-3- and adapter - 10 - 222 A /31-5- .
- Then attach spindle to front engine support eye.
- Take up weight of engine/gearbox assembly on spindle .

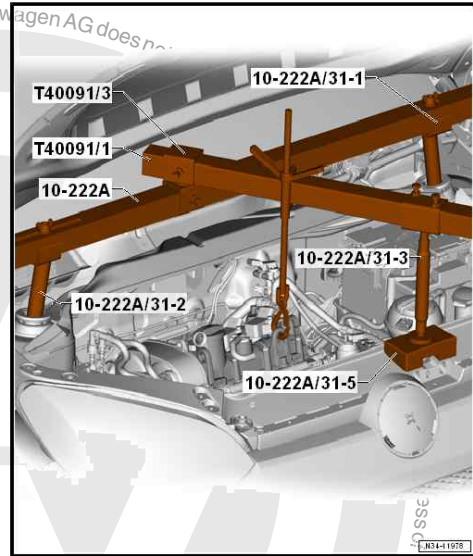

During subsequent work process, the drive shafts must be removed.

- Loosen securing nuts -arrow- for drive shafts => Running gear, axles, steering; Rep. gr. 40 ; Drive shaft; Removing and installing drive shaft .
- Cover pendulum support.

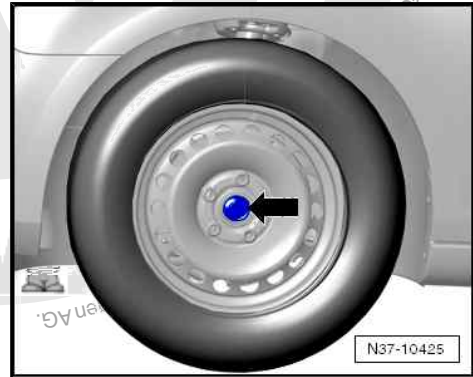

- Drain gearbox oil -arrow- => [page 134](#) .

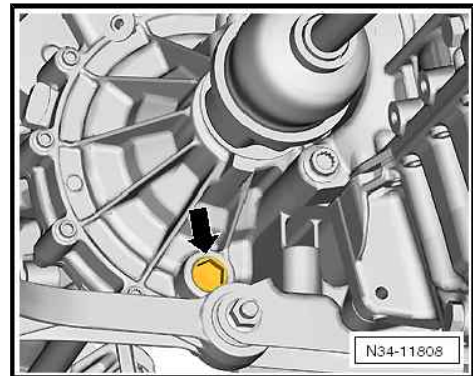

- Remove coupling rod -1- from anti-roll bar on both sides => Running gear, axles, steering; Rep. gr. 40 ; Subframe; Assembly overview – subframe .
- Press anti-roll bar upwards.
- Remove drive shafts with joint sections => Running gear, axles, steering; Rep. gr. 40 ; Drive shafts; Removing and installing drive shafts .

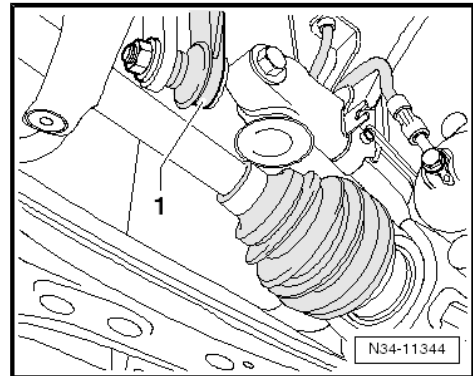



- Install sealing caps in gearbox.

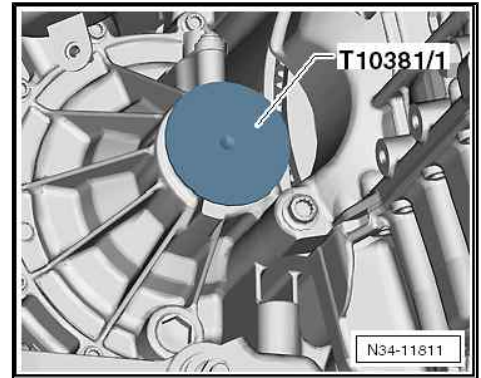

- If fitted, separate connectors.
- Pull connector -1- off gearbox neutral position sender - G701- .
- Pull connector -2- off reversing light switch - F4- .

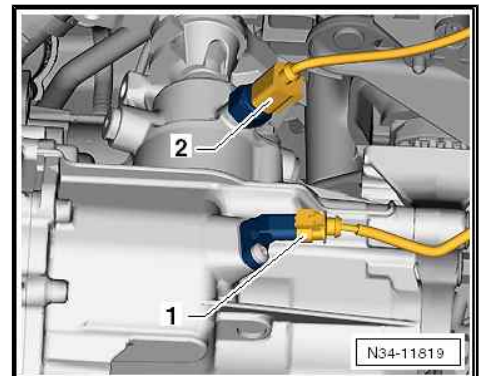

- Pull connector -1- off oil level and oil temperature sender - G266- .

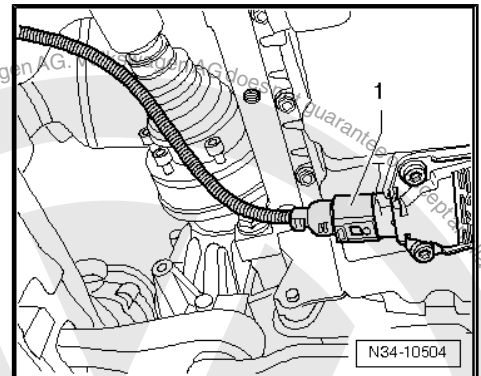

- Remove pendulum support.
- Detach exhaust system => Rep. gr. 26 ; Emission control;
Assembly overview – emission control .

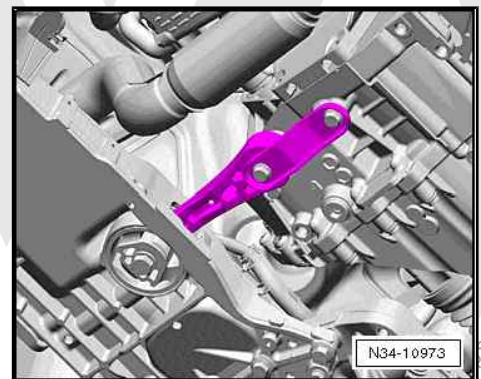



- Remove hexagon bolt -arrow- for left-hand assembly mounting from gearbox mounting.

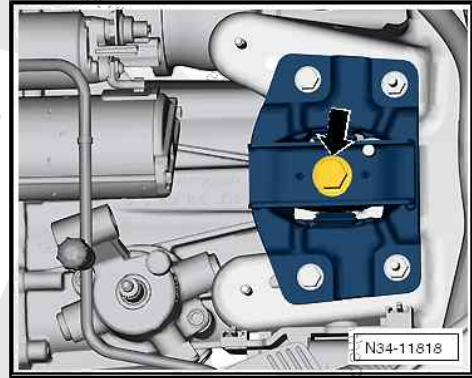

- Tilt engine/gearbox assembly.
- Securing bolts for gearbox bracket -A- must be accessible.
- Remove gearbox bracket -A-.

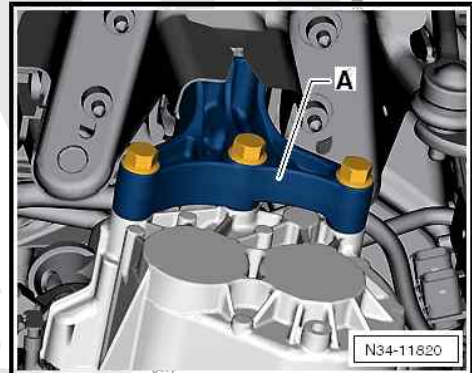

- Unscrew engine/gearbox connecting bolt -arrow- in area of right-hand drive shaft seal.

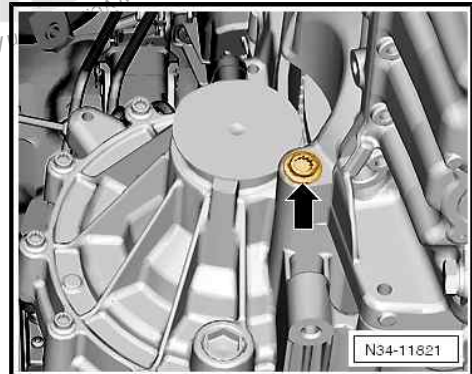

Gearbox support - 3282- is aligned with adjustment plate - 3282/63- for removal of gearbox.

- Insert gearbox support - 3282- into engine and gearbox jack .
- Align arms of gearbox support according to holes in adjustment plate .
- Attach support elements -A- to adjustment plate as illustrated.

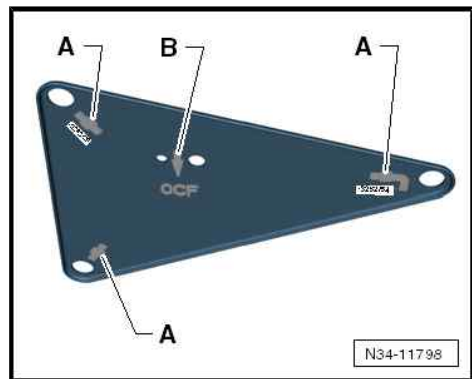



- Position engine and gearbox jack under vehicle. Arrow -B- on adjustment plate points in direction of vehicle travel.
- Align adjustment plate parallel to gearbox.
- Then screw pin - 3282/29- into rear hole on gearbox for securing bolt of pendulum support.
- Secure gearbox with adapter - 3282/64- .
- Remove lower engine/gearbox connecting bolts.
- Carefully press gearbox off dowel sleeves.

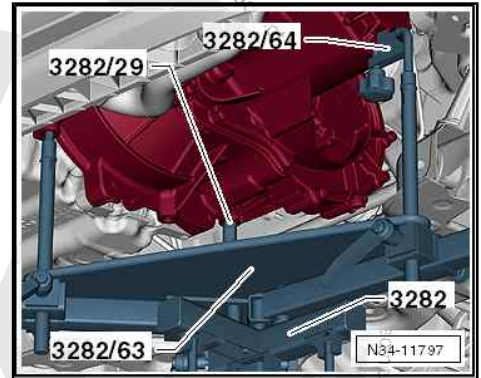

- Alternately lower gearbox ends in area of 5th gear (-area A-) and in area of differential (-arrow B-) using spindles of gearbox support - 3282- .
- When lowering gearbox, change position of gearbox using spindles of gearbox support - 3282- .

i Note

Observe connecting lines, hoses and radiator when moving engine/gearbox assembly.

⇒ ["2.3.1 Installing gearbox, up!", page 101](#)

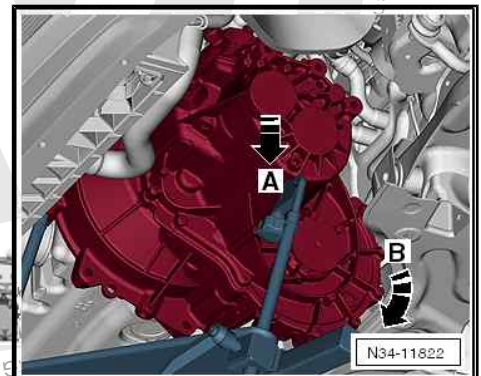

2.2.2 Removing gearbox, Polo



Special tools and workshop
equipment required

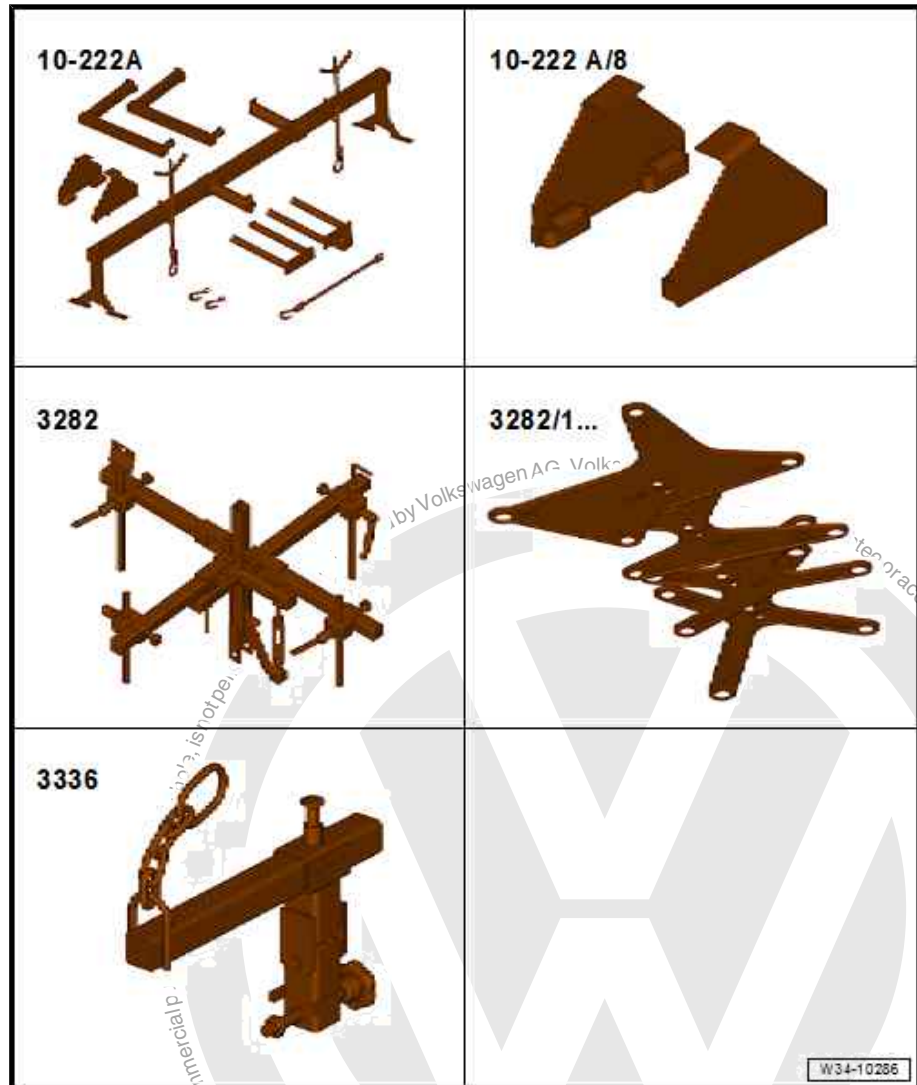

- ◆ Support - 10 - 222 A-
- ◆ Adapter - 10 - 222 A /8-
- ◆ Gearbox support - 3282-
- ◆ Adjustment plate - 3282/70-
- ◆ Support elements for gearbox (determine when setting ad-
justment plate on gearbox support)
- ◆ Gearbox lifting tackle - 3336- for transporting gearbox



- ◆ Adapter - 3282/64-
- ◆ Sealing cap - T10381/1-
- ◆ Tensioning strap - T10038-
- ◆ Insert tool - T10509-



- ◆ Torque wrench - V.A.G 1331-
- ◆ Torque wrench - V.A.G 1332-
- ◆ Engine and gearbox jack - V.A.G 1383 A-
- ◆ Or engine and gearbox jack - VAS 6931-
- ◆ Grease for splines
- ◆ Allocate grease using ⇒ Electronic parts catalogue (ETKA) .
- ◆ Allocate grease using ⇒ Electronic parts catalogue (ETKA) .
- Disconnect battery ⇒ Electrical system; Rep. gr. 27 ; Battery; Disconnecting and connecting battery .
- Remove engine cover and air filter ⇒ Rep. gr. 24 ; Air filter; Removing and installing air filter housing .
- Remove battery and battery tray ⇒ Electrical system; Rep. gr. 27 ; Battery; Removing and installing battery tray .



- Remove securing clip -1- for gear selector cable -2- from gearbox selector lever.
- Pull gear selector cable off pin.
- Remove relay lever -3- together with cable end-piece => [page 74](#) .
- Remove gearbox selector lever by unscrewing nut -4-.

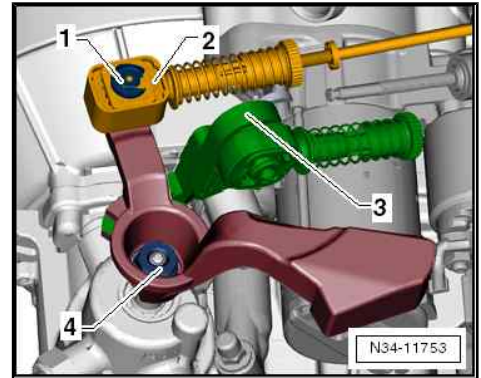

- Remove cable support bracket from gearbox.
- Bolts -arrow A- are accessible from engine compartment.
 Bolt -arrow B- is accessible from beneath vehicle.
- Tie up gear selector cable and gate selector cable.
 - Remove starter => Electrical system; Rep. gr. 27 ; Starter; Assembly overview - starter .

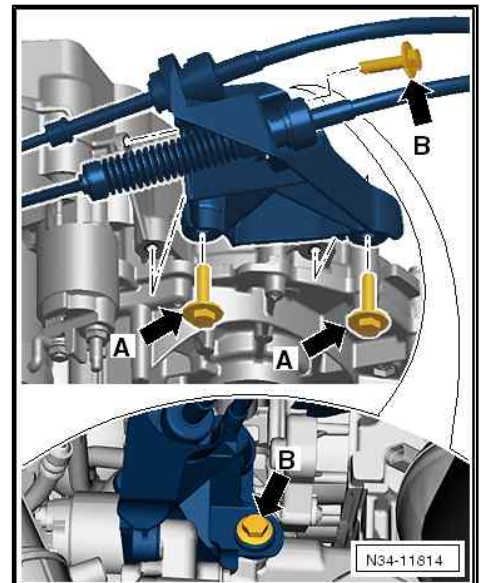

- Remove clutch slave cylinder -arrows-, lay to side and secure. Do not disconnect pipes.

Caution
 Do not operate clutch pedal any more.

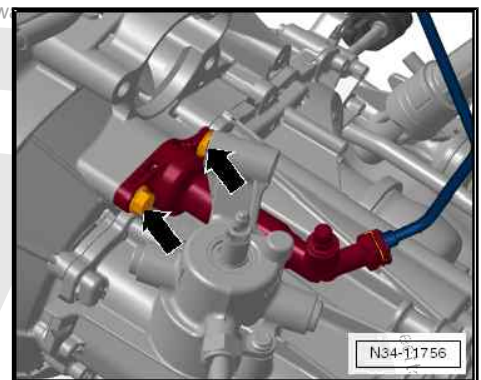

- Remove upper engine/gearbox securing bolts -arrows A- and -arrows B-.
- Loosen bolts -arrows A- if necessary using insert tool, 18 mm - T10509- .
- Remove foam pieces or seal from upper edge of left and right wings => General body repairs, exterior; Rep. gr. 50 ; Wings; Assembly overview - wings

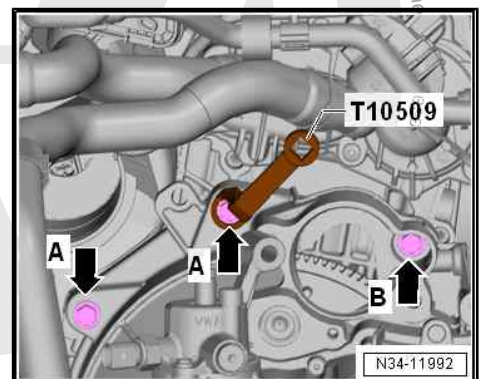



- Set up support bracket - 10-222 A- behind bonnet support.

Required material:

- ◆ Adapter - 10 - 222 A /8-
- ◆ Tensioning strap - T10038-
- Both adapters - 10 - 222 A /8- :
- need to be fitted directly in front of plenum chamber cover -arrow-.

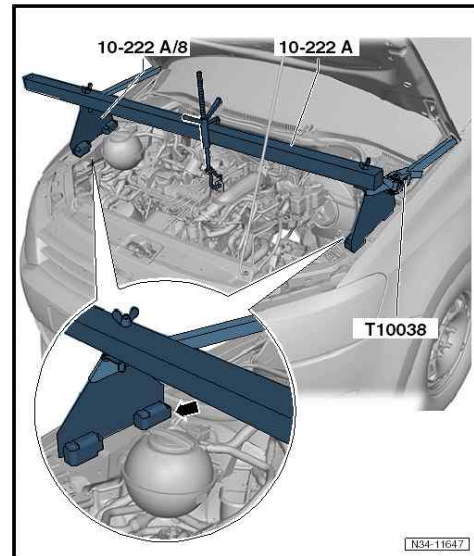

- Make sure not to damage paint on edges -arrows-.
- Secure both adapters - 10 - 222 A /8- with tensioning straps - T10038- .
- Then, attach spindle to lifting eye of engine.
- Take up weight of engine/gearbox assembly on spindle .

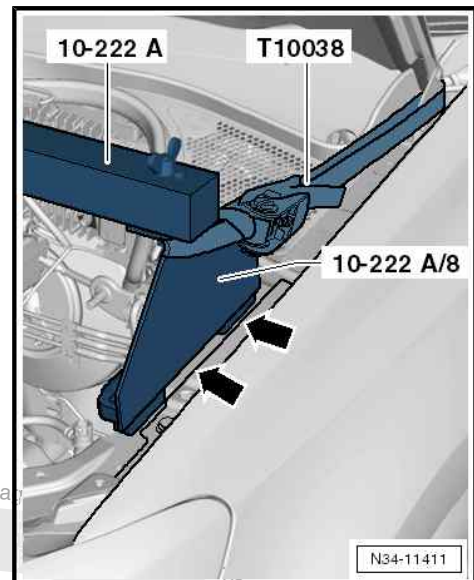

During subsequent work process, the drive shafts must be removed.

- Loosen securing nuts -arrow- for drive shafts => Running gear, axles, steering; Rep. gr. 40 ; Drive shaft; Removing and installing drive shaft .
- Cover pendulum support.

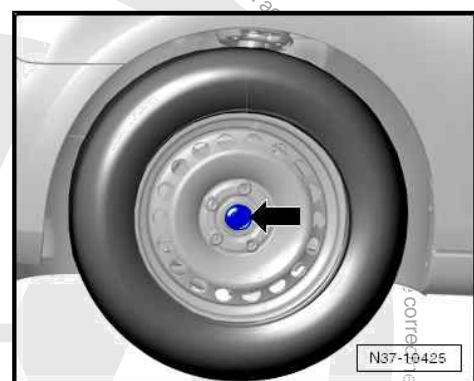



- Drain gearbox oil -arrow- => [page 134](#) .

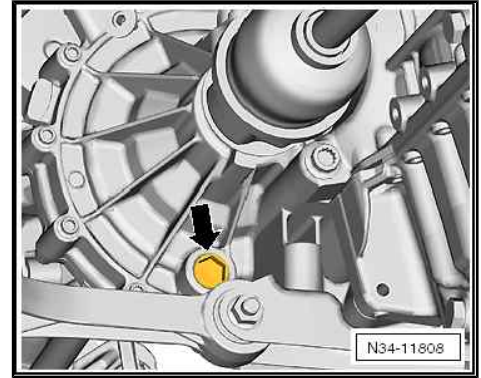

- Remove coupling rod -1- from anti-roll bar on both sides => Running gear, axles, steering; Rep. gr. 40 ; Subframe; Assembly overview – subframe .
- Press anti-roll bar upwards.
- Remove drive shafts => Running gear, axles, steering; Rep. gr. 40 ; Drive shaft; Removing and installing drive shaft .

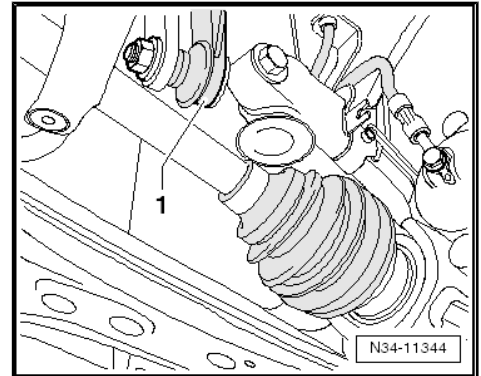

- Install sealing caps in gearbox.
- Remove cable retainer at front on gearbox => Electrical system; Rep. gr. 27 .

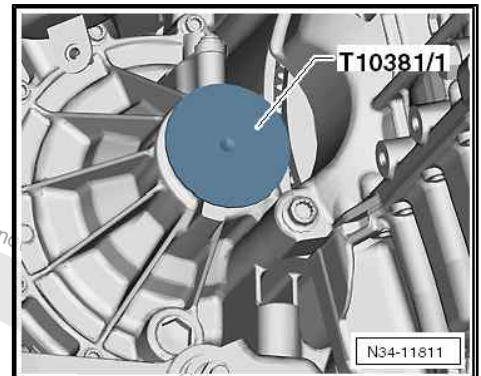

- If fitted, separate connectors.
- Pull connector -1- off gearbox neutral position sender - G701- .
- Pull connector -2- off reversing light switch - F4- .

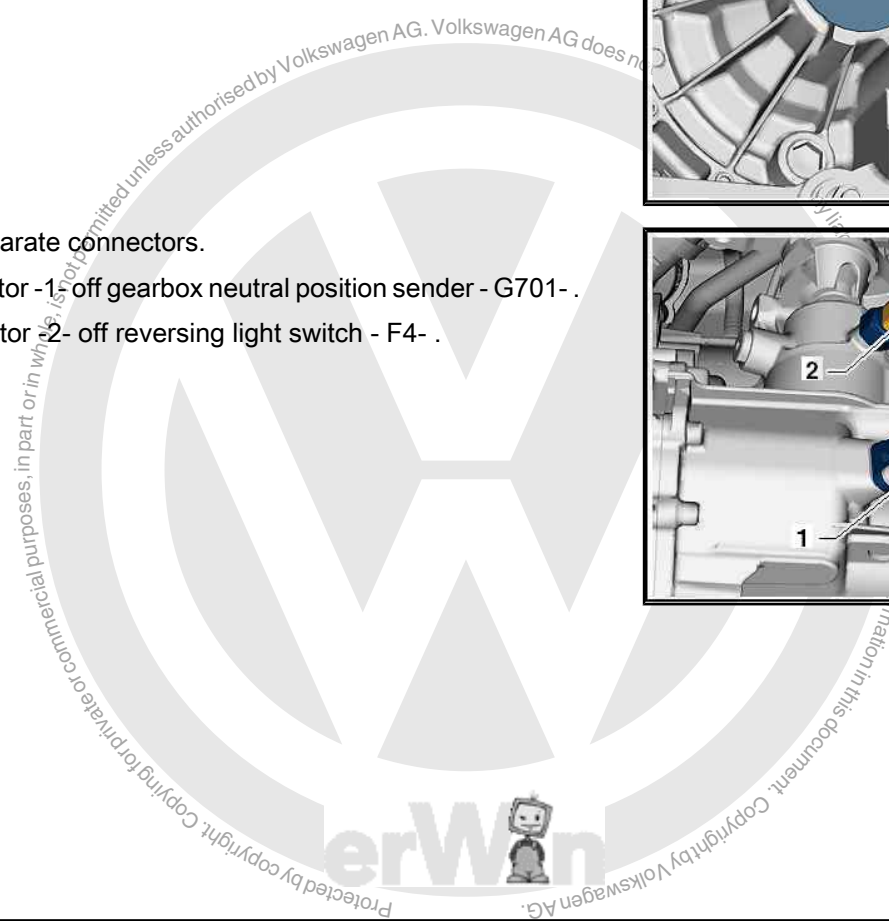
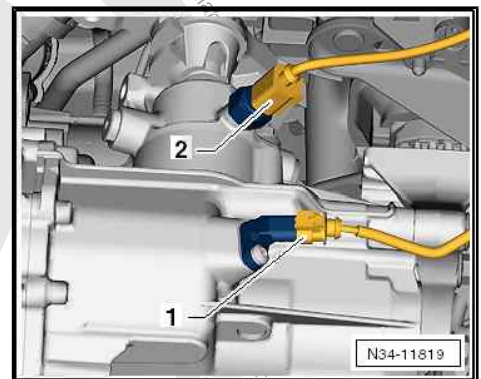



- Pull connector -1- off oil level and oil temperature sender - G266- .

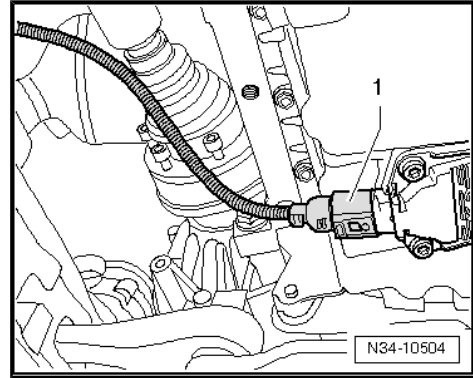

- Remove pendulum support.



Caution

Risk of damage to flexible joint.

- ◆ *Observe ⇒ Rep. gr. 26 ; Emission control; Assembly overview - emission control .*

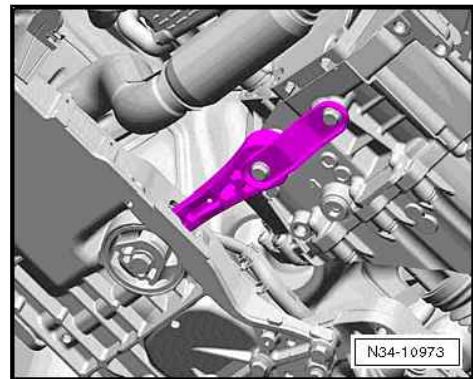

- Detach exhaust system ⇒ Rep. gr. 26 ; Emission control; Assembly overview – emission control .

- Remove hexagon bolts -arrows- for left assembly mounting from gearbox mounting.

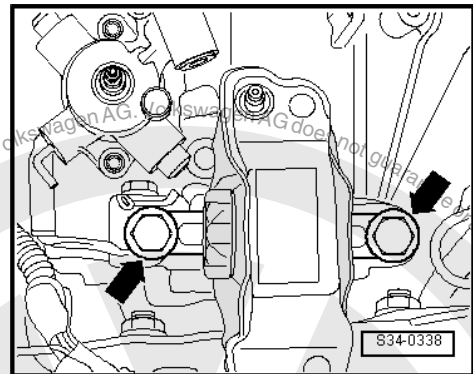

- Tilt engine/gearbox assembly.
- Securing bolts for gearbox bracket -A- must be accessible.
- Remove gearbox bracket -A-.

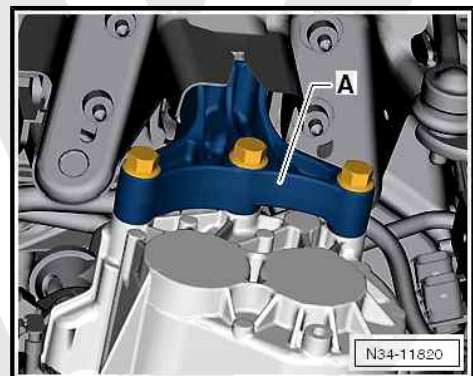



- Unscrew engine/gearbox connecting bolt -arrow- in area of right-hand drive shaft seal.

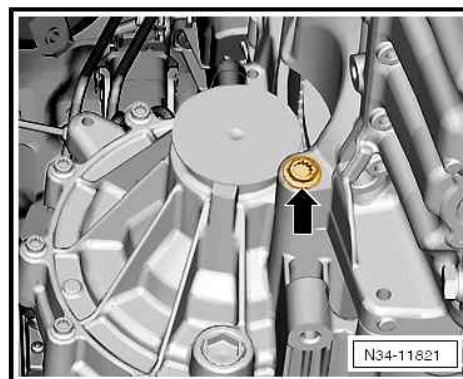

Gearbox support - 3282- is aligned with adjustment plate - 3282/70- for removal of gearbox.

- Insert gearbox support - 3282- into engine and gearbox jack .
- Align arms of gearbox support according to holes in adjustment plate .
- Attach support elements -A- to adjustment plate as illustrated.
- Position engine and gearbox jack under vehicle. Arrow -B- on adjustment plate points in direction of vehicle travel.

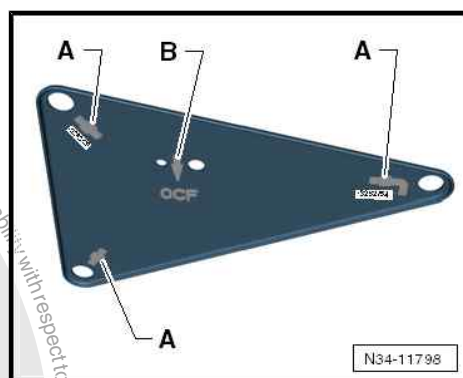

- Align adjustment plate parallel to gearbox.
- Then screw pin - 3282/29- into rear hole on gearbox for securing bolt of pendulum support.
- Secure gearbox with adapter - 3282/64- .
- Remove lower engine/gearbox connecting bolts.
- Carefully press gearbox off dowel sleeves.
- When lowering gearbox, change position of gearbox using spindles of gearbox support - 3282- .

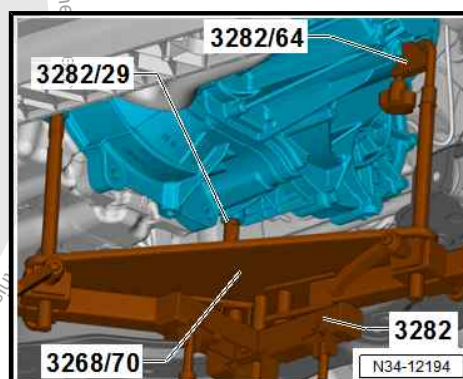

Note

Observe connecting lines, hoses and radiator when moving engine/gearbox assembly.

⇒ ["2.3.2 Installing gearbox, Polo", page 106](#)

2.3 Installing gearbox

⇒ ["2.3.1 Installing gearbox, up!", page 101](#)

⇒ ["2.3.2 Installing gearbox, Polo", page 106](#)

2.3.1 Installing gearbox, up!



Note

Refer to procedure "Removing gearbox" for required special tools
⇒ [page 85](#) .

- If the gearbox is to be renewed, the gearbox selector lever and relay lever must be transferred to the new gearbox.



- All threaded holes into which self-locking bolts are to be screwed must be cleaned of residual locking fluid carefully with a thread tap.
- Clean input shaft splines and apply thin coat of grease for clutch plate splines .

The clutch plate must slide easily to and fro on the input shaft.

- If no dowel sleeves for aligning engine and gearbox are fitted in cylinder block, install if necessary.

If dowel sleeves are not fitted, difficulties shifting gears, clutch problems and possible noises from the gearbox (rattling of gears which are not engaged) could occur.

Gearbox support - 3282- is aligned with adjustment plate - 3282/63- for installation of gearbox.

- Insert gearbox support - 3282- into engine and gearbox jack .
- Align arms of gearbox support according to holes in adjustment plate .
- Attach support elements -A- to adjustment plate as illustrated.

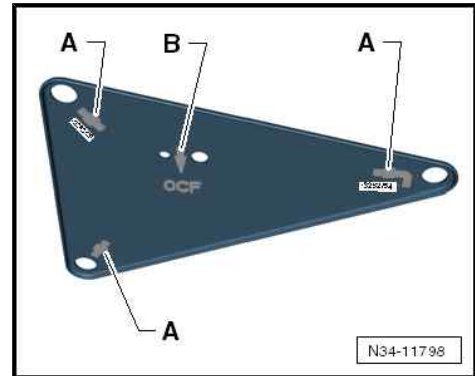

- Align gearbox parallel to adjustment plate and set on engine and gearbox jack .
- Then screw pin - 3282/29- into rear hole on gearbox for securing bolt of pendulum support.
- Secure gearbox with adapter - 3282/64- .
- Position engine and gearbox jack under vehicle. Arrow -B- on adjustment plate points in direction of vehicle travel.

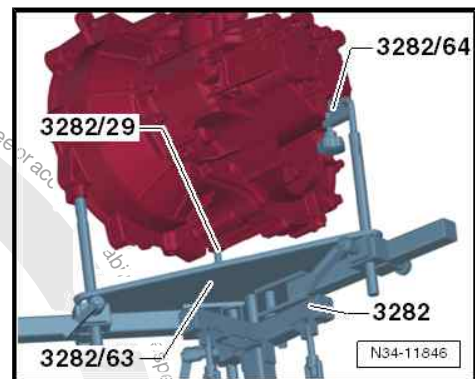

Gearbox ends in area of 5th gear (-area A-) and in area of differential (-arrow B-) are facing downwards.

- Then raise gearbox carefully and guide past subframe.

i Note

Be careful of all lines when installing gearbox.

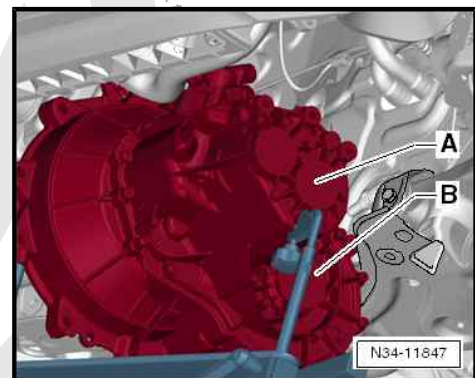



- Line up gearbox and install.
- Screw in engine/gearbox connecting bolt -arrow- in area of right drive shaft seal ⇒ [page 85](#) .
- Install lower engine/gearbox securing bolts ⇒ [page 85](#) .
- After gearbox has been bolted to engine, remove engine and gearbox jack from gearbox.

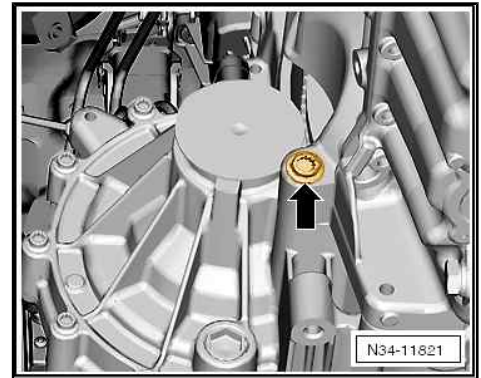

- Fit gearbox bracket -A- with new bolts ⇒ [page 110](#) .

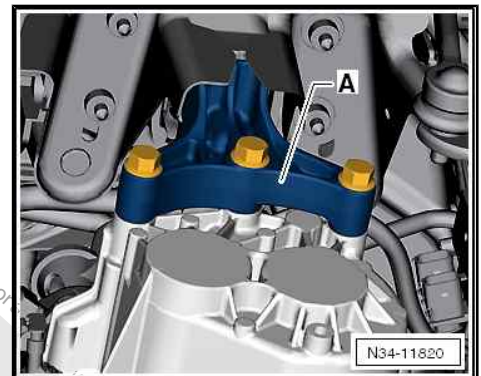

- Align engine and gearbox in installation position.
- Install new bolt -arrow- for left assembly mounting in gearbox mounting ⇒ [page 110](#) .
- Do not remove engine support bracket - 10 - 222 A- until all bolts securing the assembly mounting have been tightened to specified torque.
- If previously removed, fit bonnet seal to lock carrier.

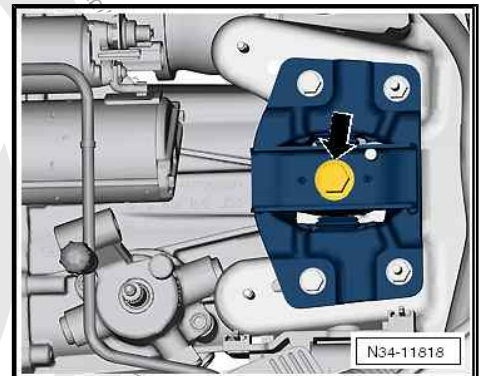

- Install upper engine/gearbox securing bolts -arrows A- and -arrows B- ⇒ [page 85](#) .
- Bolts -arrows A- can be tightened using insert tool, 18 mm - T10509- .
- Fit earth strap if necessary.

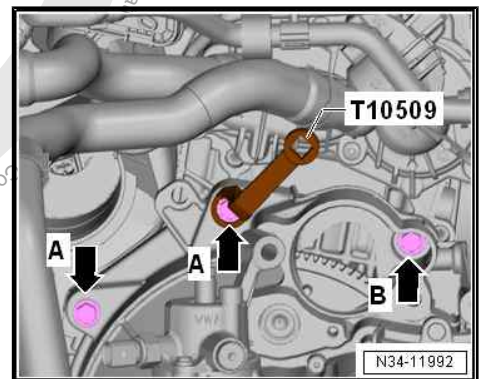



- Install pendulum support using new bolts ⇒ Rep. gr. 10 ; Assembly mountings; Assembly overview – assembly mountings .
- Install exhaust system ⇒ Rep. gr. 26 ; Emission control; Assembly overview – emission control .
- Install drive shafts ⇒ Running gear, axles, steering; Rep. gr. 40 ; Drive shaft; Removing and installing drive shafts
- Install coupling rod -1- to anti-roll bar on both sides ⇒ Running gear, axles, steering; Rep. gr. 40 ; Subframe; Assembly overview – subframe .
- If present, join connectors as follows:
 - Fit connector -1- to gearbox neutral position sender - G701- .
 - Fit connector -2- to reversing light switch - F4-
- Fit connector -1- to oil level and oil temperature sender - G266- .

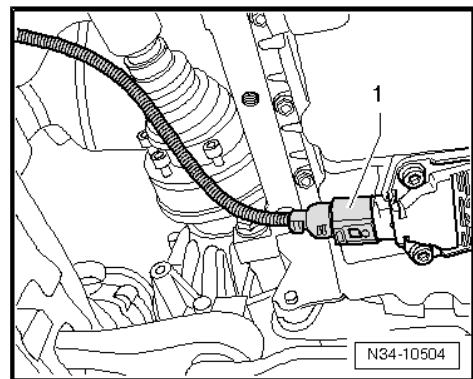
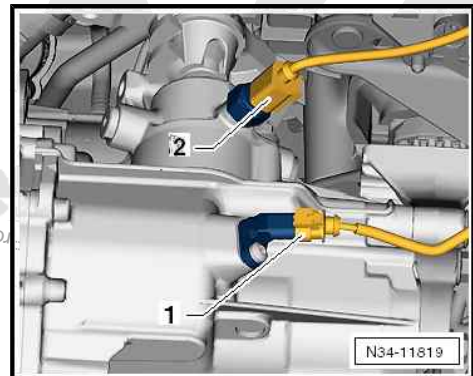
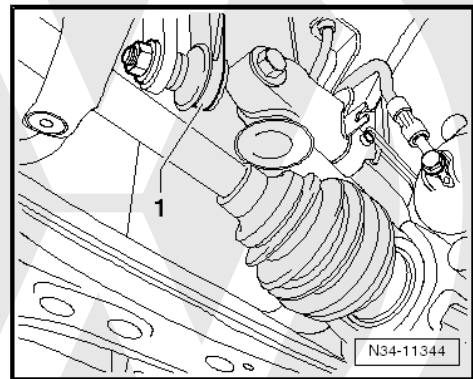
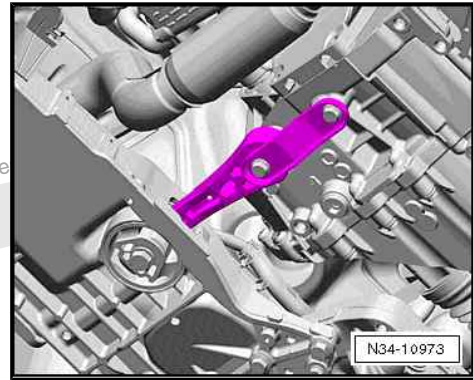



- Install clutch slave cylinder -arrows- ⇒ [page 41](#) .
- Install starter ⇒ Electrical system; Rep. gr. 27 ; Starter; Assembly overview - starter .

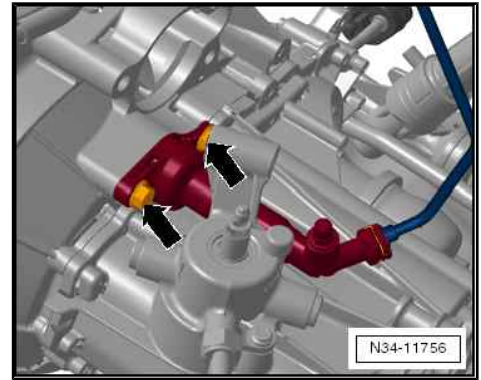

- Install cable support bracket to gearbox ⇒ [page 65](#) .
- Bolts -arrow A- are accessible from engine compartment.
Bolt -arrow B- is accessible from beneath vehicle.

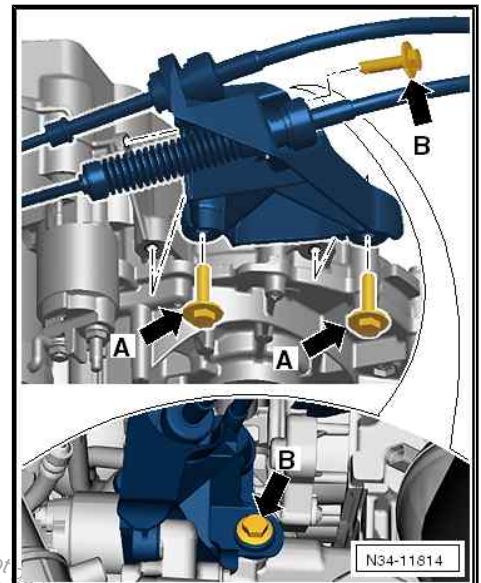

- Install gearbox selector lever and tighten hexagon nut -4- to specified torque ⇒ [page 65](#) .
- Install relay lever -3- together with cable end-piece ⇒ [page 74](#) ⇒ [page 74](#) .
- Spread a small amount of grease on pin of gearbox selector lever.

Allocate grease using ⇒ Electronic parts catalogue (ETKA) .

- Attach gear selector cable -2- to gearbox selector lever.
- Install new clip -1-.
- Adjust selector mechanism ⇒ [page 76](#) .
- Fill with gear oil ⇒ [page 134](#) .
- Install battery ⇒ Electrical system; Rep. gr. 27 ; Battery; Removing and installing battery .
- Connect battery and follow procedure after connecting battery ⇒ Electrical system; Rep. gr. 27 ; Disconnecting and connecting battery .
- Install engine cover and air filter ⇒ Rep. gr. 24 ; Air filter; Removing and installing air filter housing .

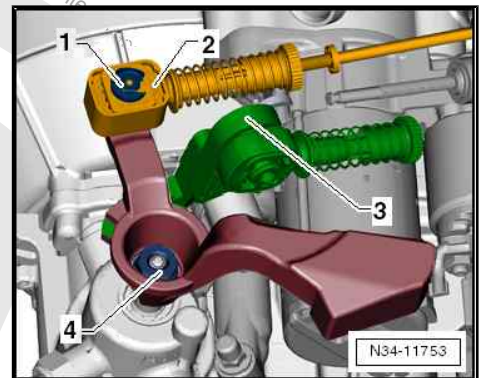



2.3.2 Installing gearbox, Polo



Note

Refer to procedure "Removing gearbox" for required special tools
⇒ [page 93](#) .

- If the gearbox is to be renewed, the gearbox selector lever and relay lever must be transferred to the new gearbox.
- All threaded holes into which self-locking bolts are to be screwed must be cleaned of residual locking fluid carefully with a thread tap.
- Clean input shaft splines and apply thin coat of grease for clutch plate splines .

The clutch plate must slide easily to and fro on the input shaft.

- If no dowel sleeves for aligning engine and gearbox are fitted in cylinder block, install if necessary.

If dowel sleeves are not fitted, difficulties shifting gears, clutch problems and possible noises from the gearbox (rattling of gears which are not engaged) could occur.

Gearbox support - 3282- is aligned with adjustment plate - 3282/70- for installation of gearbox.

- Insert gearbox support - 3282- into engine and gearbox jack .
- Align arms of gearbox support according to holes in adjustment plate .
- Attach support elements -A- to adjustment plate as illustrated.

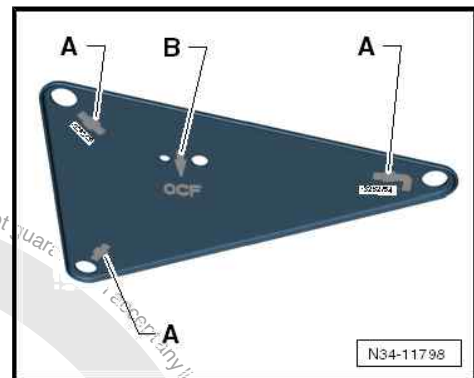

- Align gearbox parallel to adjustment plate and set on engine and gearbox jack .
- Then screw pin - 3282/29- into rear hole on gearbox for securing bolt of pendulum support.
- Secure gearbox with adapter - 3282/64- .
- Position engine and gearbox jack under vehicle. Arrow -B- on adjustment plate points in direction of vehicle travel.
- Then raise gearbox carefully and guide past subframe.

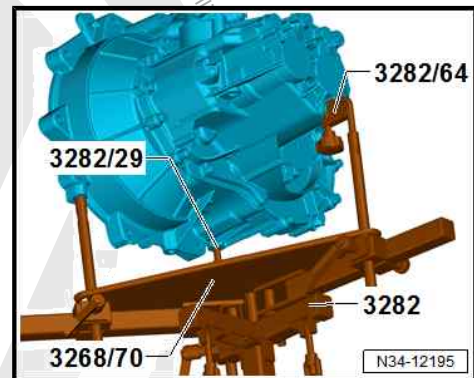

Note

Be careful of all lines when installing gearbox.



Note

Be careful of all lines when installing gearbox.



- Line up gearbox and install.
- Screw in engine/gearbox connecting bolt -arrow- in area of right drive shaft seal ⇒ [page 85](#) .
- Install lower engine/gearbox securing bolts ⇒ [page 85](#) .
- After gearbox has been bolted to engine, remove engine and gearbox jack from gearbox.

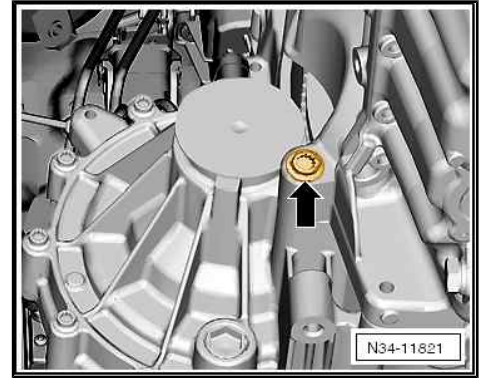

- Fit gearbox bracket -A- with new bolts ⇒ [page 112](#) .

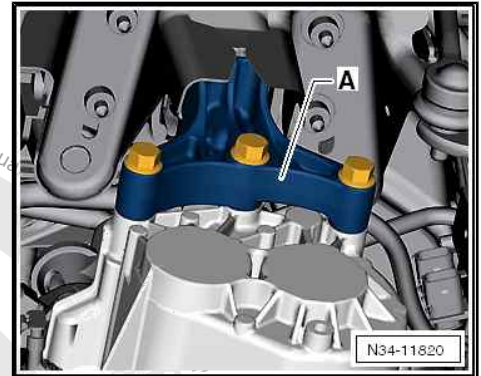

- Align engine and gearbox in installation position.
- Install new bolts -arrows- for left assembly mounting in gearbox mounting ⇒ [page 112](#) .
- After having tightened all assembly mounting bolts to specified torque, remove engine and gearbox jack .
- If previously removed, fit bonnet seal to lock carrier.

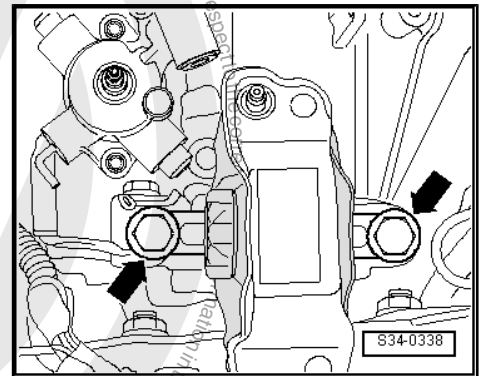

- Install upper engine/gearbox securing bolts -arrows A- and -arrows B- ⇒ [page 85](#) .
- Bolts -arrows A- can be tightened using insert tool, 18 mm - T10509- .
- Fit earth strap if necessary.

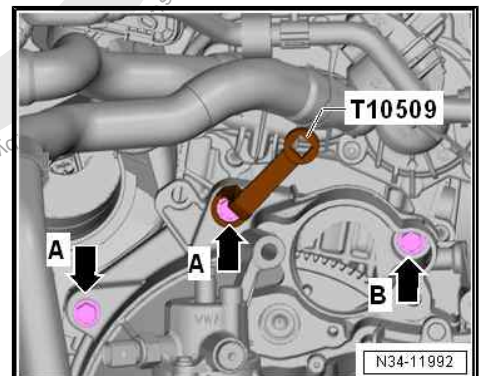



- Install pendulum support using new bolts ⇒ Rep. gr. 10 ; Assembly mountings; Assembly overview – assembly mountings .
- Install exhaust system ⇒ Rep. gr. 26 ; Emission control; Assembly overview – emission control .
- Install drive shafts ⇒ Running gear, axles, steering; Rep. gr. 40 ; Drive shaft; Removing and installing drive shafts .

- Install coupling rod -1- to anti-roll bar on both sides ⇒ Running gear, axles, steering; Rep. gr. 40 ; Subframe; Assembly overview – subframe .

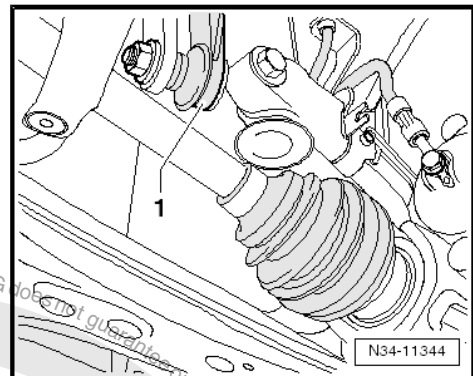
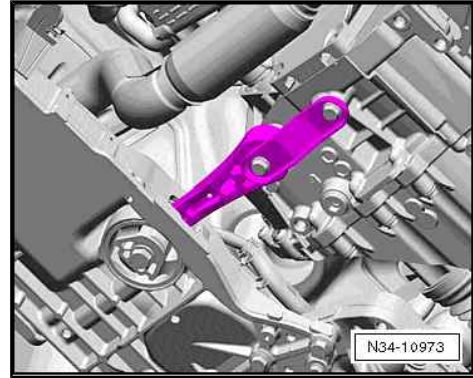

- If present, join connectors as follows:
- Fit connector -1- to gearbox neutral position sender - G701- .
- Fit connector -2- to reversing light switch - F4- .

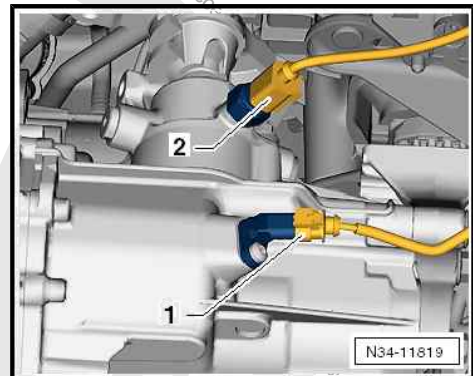

- Fit connector -1- to oil level and oil temperature sender - G266- .
- Install cable retainer at front on gearbox ⇒ Electrical system; Rep. gr. 27 .

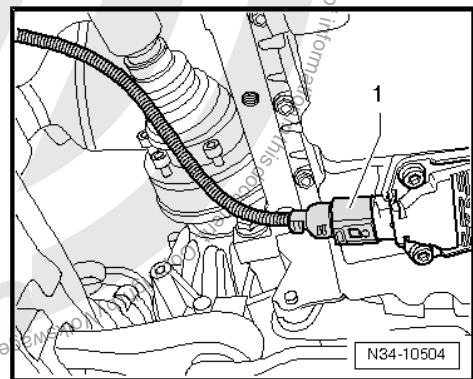



- Install clutch slave cylinder -arrows- ⇒ [page 41](#) .
- Install starter ⇒ Electrical system; Rep. gr. 27 ; Starter; Assembly overview - starter .

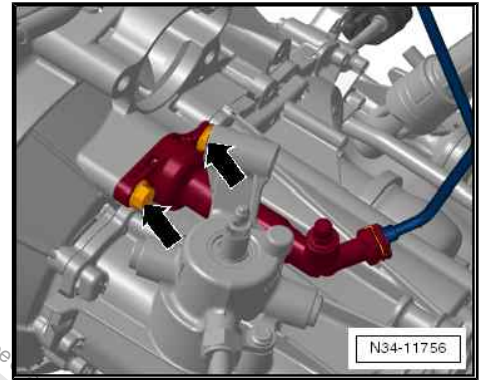

- Install cable support bracket to gearbox ⇒ [page 65](#) .
- Bolts -arrow A- are accessible from engine compartment.
 Bolt -arrow B- is accessible from beneath vehicle.

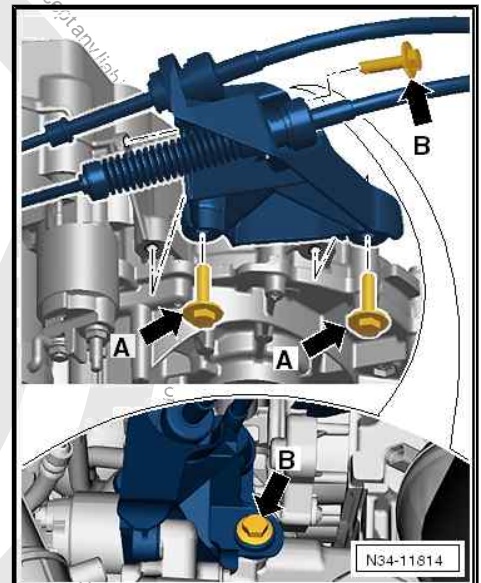

- Install gearbox selector lever and tighten hexagon nut -4- to specified torque ⇒ [page 65](#) .
- Install relay lever -3- together with cable end-piece ⇒ [page 74](#) ⇒ [page 74](#) .
- Spread a small amount of grease on pin of gearbox selector lever.

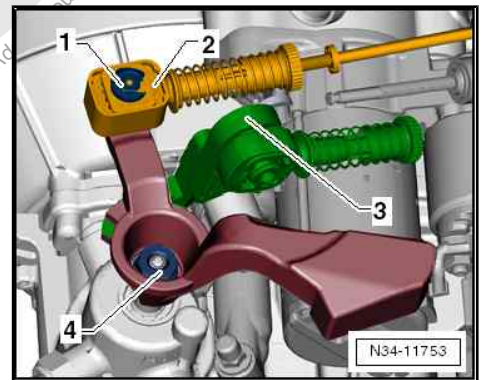

Allocate grease using ⇒ Electronic parts catalogue (ETKA) .

- Attach gear selector cable -2- to gearbox selector lever.
- Install new clip -1-.
- Adjust selector mechanism ⇒ [page 76](#) .
- Fill with gear oil ⇒ [page 134](#) .
- Install battery ⇒ Electrical system; Rep. gr. 27 ; Battery; Removing and installing battery .
- Connect battery and follow procedure after connecting battery ⇒ Electrical system; Rep. gr. 27 ; Disconnecting and connecting battery .
- Install engine cover and air filter ⇒ Rep. gr. 24 ; Air filter; Removing and installing air filter housing .
- Install foam pieces or seal at upper edge of left and right wings ⇒ General body repairs, exterior; Rep. gr. 50 ; Wings; Assembly overview – wings .



3 Assembly mountings

⇒ [“3.1 Assembly overview - assembly mountings”, page 110](#)

3.1 Assembly overview - assembly mountings

⇒ [“3.1.1 Assembly overview – assembly mountings, up!”](#), page 110

⇒ [“3.1.2 Assembly overview – assembly mountings, Polo”](#), page 112

3.1.1 Assembly overview – assembly mountings, up!

1 - Engine mounting

- ⇒ Rep. gr. 10 ; Assembly mountings; Assembly overview - assembly mountings

2 - Bolt

- Pendulum support to subframe
- ⇒ Rep. gr. 10 ; Assembly mountings; Assembly overview - assembly mountings

3 - Pendulum support

- ⇒ Rep. gr. 10 ; Assembly mountings; Assembly overview - assembly mountings

4 - Bolt

- Pendulum support to gearbox
- ⇒ Rep. gr. 10 ; Assembly mountings; Assembly overview - assembly mountings

5 - Bolt

- Renew after removal
- Gearbox bracket to gearbox
- 40 Nm +90°

6 - Gearbox bracket

7 - Gearbox mounting

- ⇒ Rep. gr. 10 ; Assembly mountings; Assembly overview - assembly mountings

8 - Bolt

- Gearbox mounting to body
- ⇒ Rep. gr. 10 ; Assembly mountings; Assembly overview - assembly mountings

9 - Bolt

- Gearbox mounting to body
- ⇒ Rep. gr. 10 ; Assembly mountings; Assembly overview - assembly mountings

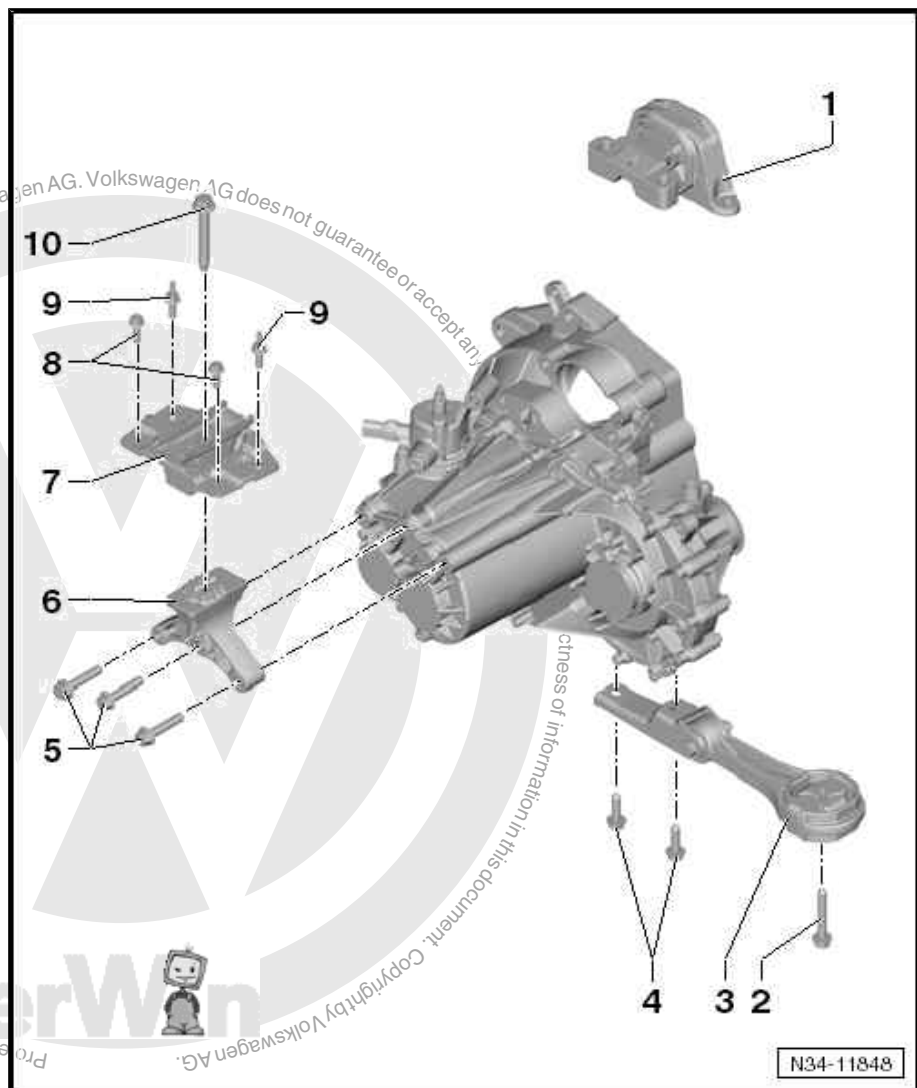



10 - Bolt

- Renew after removal
- Gearbox bracket to gearbox mounting
- 60 Nm +180°

Gearbox bracket -A- to gearbox

Renew bolts.

- Screw in all bolts hand-tight.
- Tighten bolts to specified torque ⇒ [Item 5 \(page 110\)](#) .

Gearbox to body

- Renew bolt.
- Tighten bolts by hand.
- Tighten bolt to specified torque ⇒ [Item 10 \(page 111\)](#) .

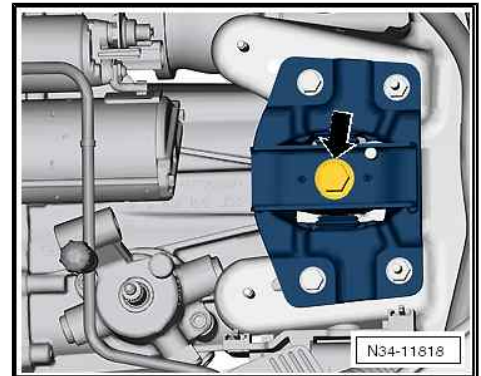
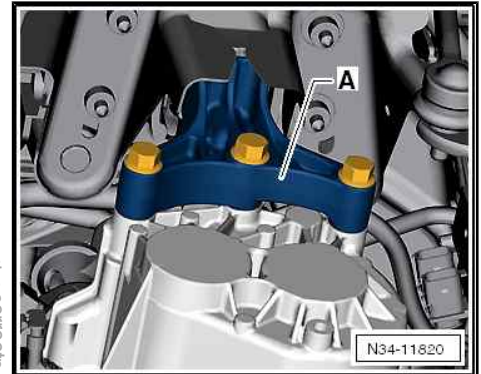



3.1.2 Assembly overview – assembly mountings, Polo

1 - Bolt

- Qty. 2
- Renew after removal
- Gearbox bracket to gearbox mounting
- 40 Nm +90°

2 - Bolt

- Gearbox mounting to body
- ⇒ Rep. gr. 10 ; Assembly mountings; Assembly overview - assembly mountings

3 - Gearbox mounting

- ⇒ Rep. gr. 10 ; Assembly mountings; Assembly overview - assembly mountings

4 - Gearbox bracket

5 - Bolt

- Qty. 3
- Renew after removal
- Gearbox bracket to gearbox
- 40 Nm +90°

6 - Pendulum support

- ⇒ Rep. gr. 10 ; Assembly mountings; Assembly overview - assembly mountings

7 - Bolt

- Pendulum support to subframe
- ⇒ Rep. gr. 10 ; Assembly mountings; Assembly overview - assembly mountings

8 - Bolt

- Pendulum support to gearbox
- ⇒ Rep. gr. 10 ; Assembly mountings; Assembly overview - assembly mountings

9 - Engine mounting

- ⇒ Rep. gr. 10 ; Assembly mountings; Assembly overview - assembly mountings

10 - Bolt

- Qty. 4
- Engine mounting to body
- ⇒ Rep. gr. 10 ; Assembly mountings; Assembly overview - assembly mountings

11 - Bolt

- Engine mounting to engine
- ⇒ Rep. gr. 10 ; Assembly mountings; Assembly overview - assembly mountings

12 - Bolt

- Qty. 2
- Engine mounting to engine

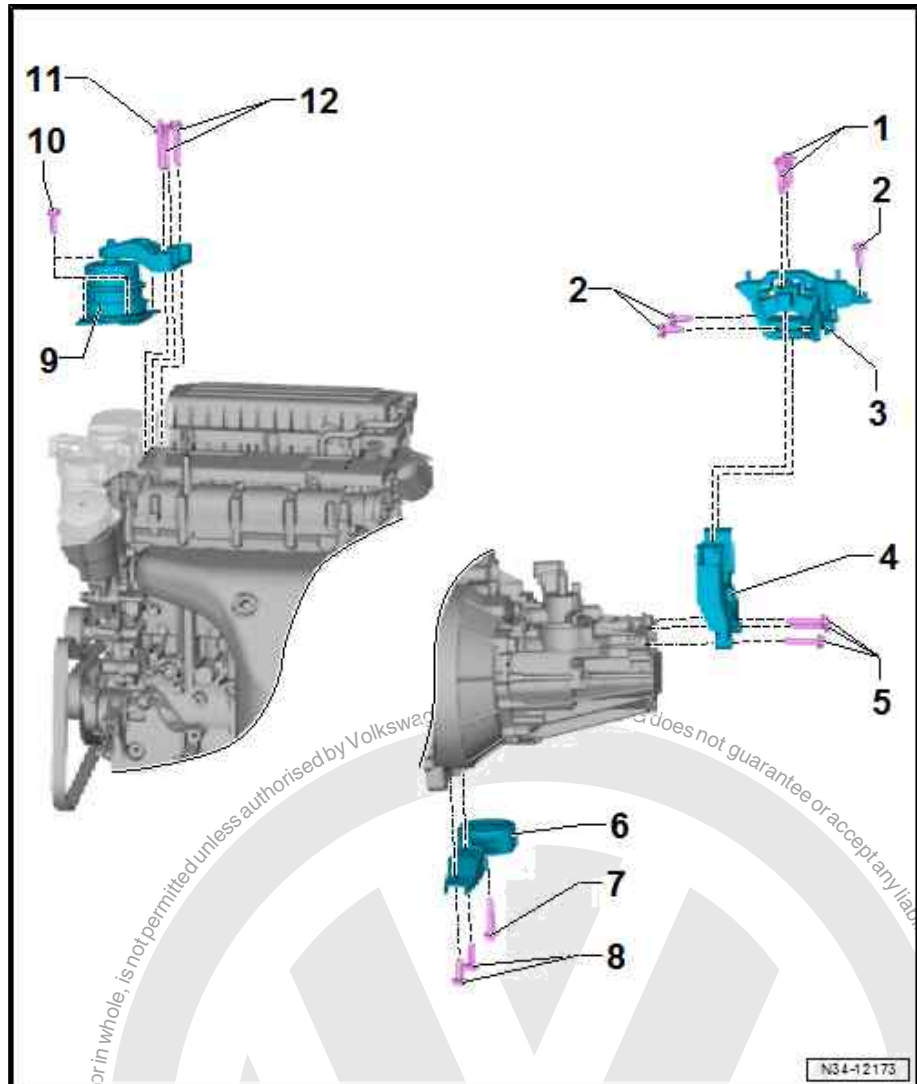



□ ⇒ Rep. gr. 10 ; Assembly mountings; Assembly overview - assembly mountings

Gearbox bracket -A- to gearbox

- Renew bolts.
- Screw in all bolts hand-tight.
- Tighten bolts to specified torque ⇒ [Item 5 \(page 112\)](#) .

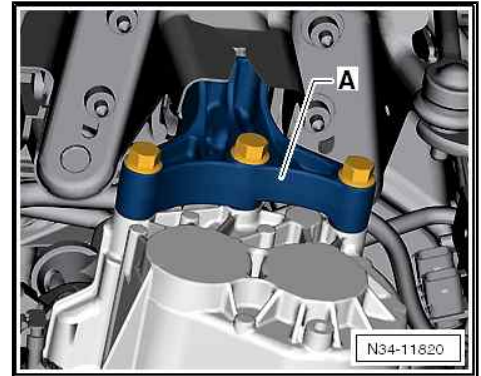

Gearbox bracket to gearbox mounting

- Renew bolts.
- Tighten bolts by hand.
- Tighten bolt to specified torque ⇒ [Item 1 \(page 112\)](#) .



Note

Install engine and gearbox mounting free of tension ⇒ Rep. gr. 10 ; Removing and installing engine .

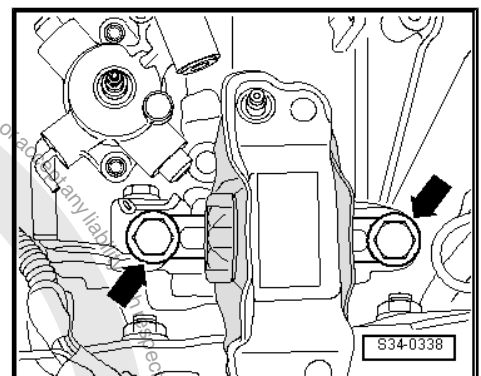



4 Transporting gearbox

Special tools and workshop equipment required

- ◆ Gearbox mounting support - 3336-



- ◆ Workshop hoist - VAS 6100-



- Bolt gearbox lifting tackle - 3336- to clutch housing.

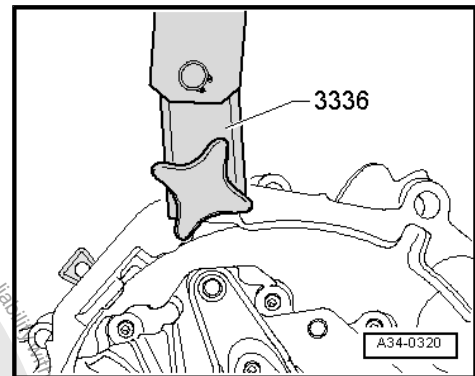

Adjust support beam on sliding piece using locking pin -arrow-.

Number of holes visible = 5.

Lift gearbox using workshop crane and gearbox lifting tackle - 3336- .

Set gearbox aside, for example in a transport container.

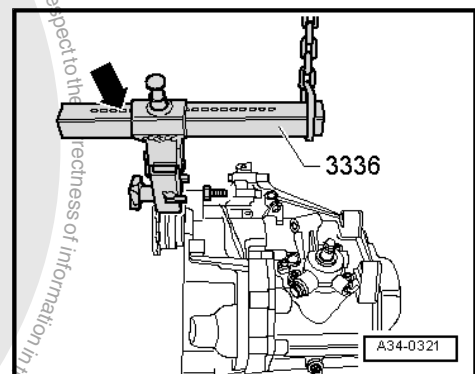



5 Dismantling and assembling gearbox

⇒ [“5.1 Schematic overview - gearbox”, page 115](#)

⇒ [“5.2 Assembly overview - gearbox”, page 116](#)

⇒ [“5.3 Assembly overview - clutch housing”, page 117](#)

⇒ [“5.4 Assembly overview - selector unit”, page 118](#)

⇒ [“5.5 Assembly overview - shafts, differential, selector mechanism”, page 119](#)

⇒ [“5.6 Removing and installing selector unit with gearbox installed”, page 119](#)

⇒ [“5.7 Renewing selector shaft sleeve”, page 123](#)

⇒ [“5.8 Dismantling and assembling gearbox”, page 124](#)

5.1 Schematic overview - gearbox

- 1 - 1st gear
- 2 - 2nd gear
- 3 - 3rd gear
- 4 - 4th gear
- 5 - 5th gear
- 6 - Reverse gear wheel
- 7 - Gearbox housing
- 8 - Clutch housing
- 9 - Input shaft
- 10 - Output shaft
- 11 - Differential
- 12 - Selector mechanism

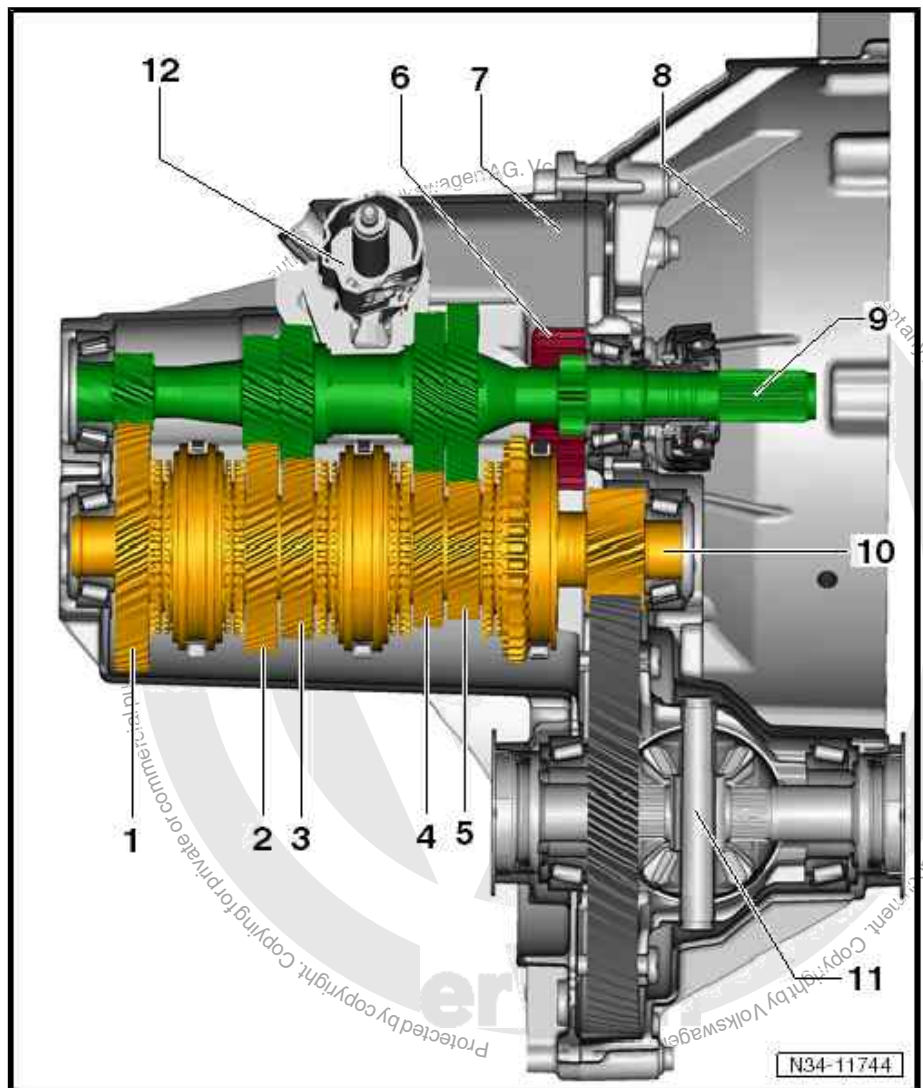



5.2 Assembly overview - gearbox

I -
⇒ ["5.3 Assembly overview - clutch housing", page 117](#)

II -
⇒ ["5.4 Assembly overview - selector unit", page 118](#)

II -
⇒ ["5.5 Assembly overview - shafts, differential, selector mechanism", page 119](#)

II -
⇒ ["5.7 Renewing selector shaft sleeve", page 123](#)

II -
⇒ ["1.14 Renewing selector shaft seal", page 83](#)

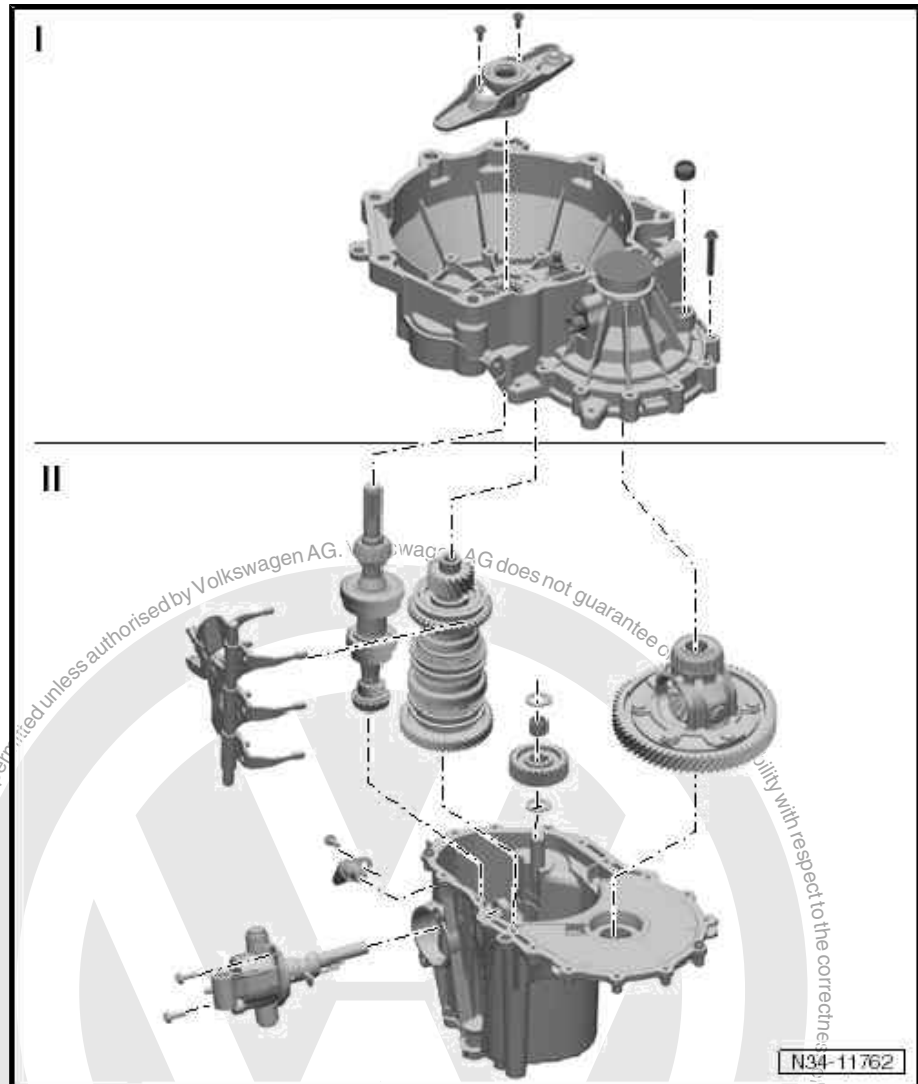



5.3 Assembly overview - clutch housing

1 - Clutch housing

- Allocation ⇒ Electronic parts catalogue (ETKA)
- Repairing ⇒ [page 131](#)

2 - Oil drain plug

- 30 Nm

3 - Bolt

- Renew after removal
- 5 Nm and turn 90° further

4 - Gearbox housing

- Allocation ⇒ Electronic parts catalogue (ETKA)
- Repairing ⇒ [page 131](#)

5 - Clutch release lever

- With guide sleeve and release bearing
- To remove and install, remove gearbox
- Removing and installing ⇒ [page 51](#)

6 - Bolt

- Removing and installing ⇒ [page 24](#)

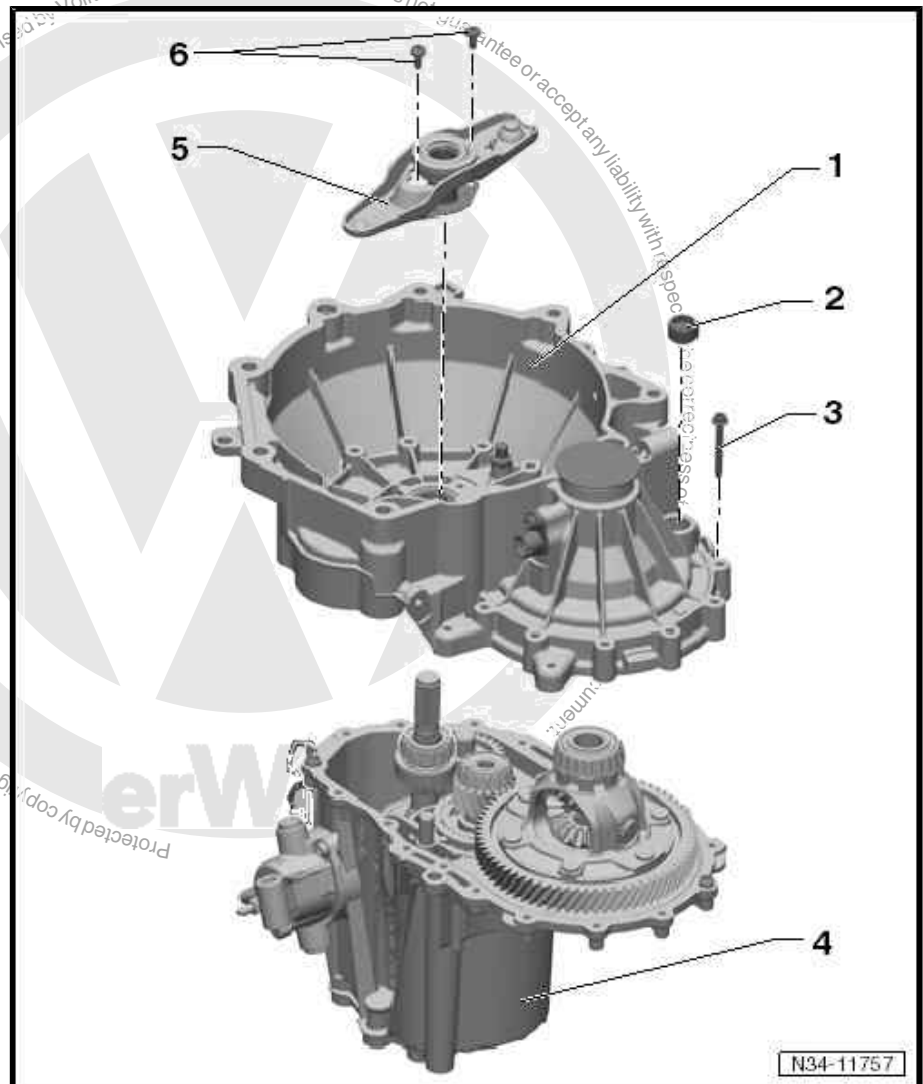



5.4 Assembly overview - selector unit

1 - Sleeve

- For selector shaft
- Renew after removal
⇒ [page 123](#)

2 - Reversing light switch - F4-

- Switch without seal: clean thread of switch if necessary
- Switch without seal: install switch with sealant if necessary
- For allocation of sealant, refer to ⇒ Electronic parts catalogue (ET-KA).
- Switch with encapsulated seal: renew switch
- Switch with separate seal: renew seal
- Lightly coat lug with MoS₂ grease
- Tighten to 20 Nm

3 - Selector unit

- (Selector shaft with selector shaft cover)
⇒ [page 118](#)
- Removing and installing with gearbox installed
⇒ [page 119](#)

4 - Relay lever

- Installing
⇒ [Item 16 \(page 66\)](#)

5 - Clip

6 - Hexagon nut

- Self-locking
- Renew after removal
- 25 Nm

7 - Gearbox selector lever

- Illustration may differ from original component.
- Install so that master spline aligns with selector shaft
- Can be renewed with the selector mechanism installed
- Fitting position ⇒ [page 74](#)

8 - Seal

- Renew after removal ⇒ [page 83](#)

9 - Cap

- For gearbox breather

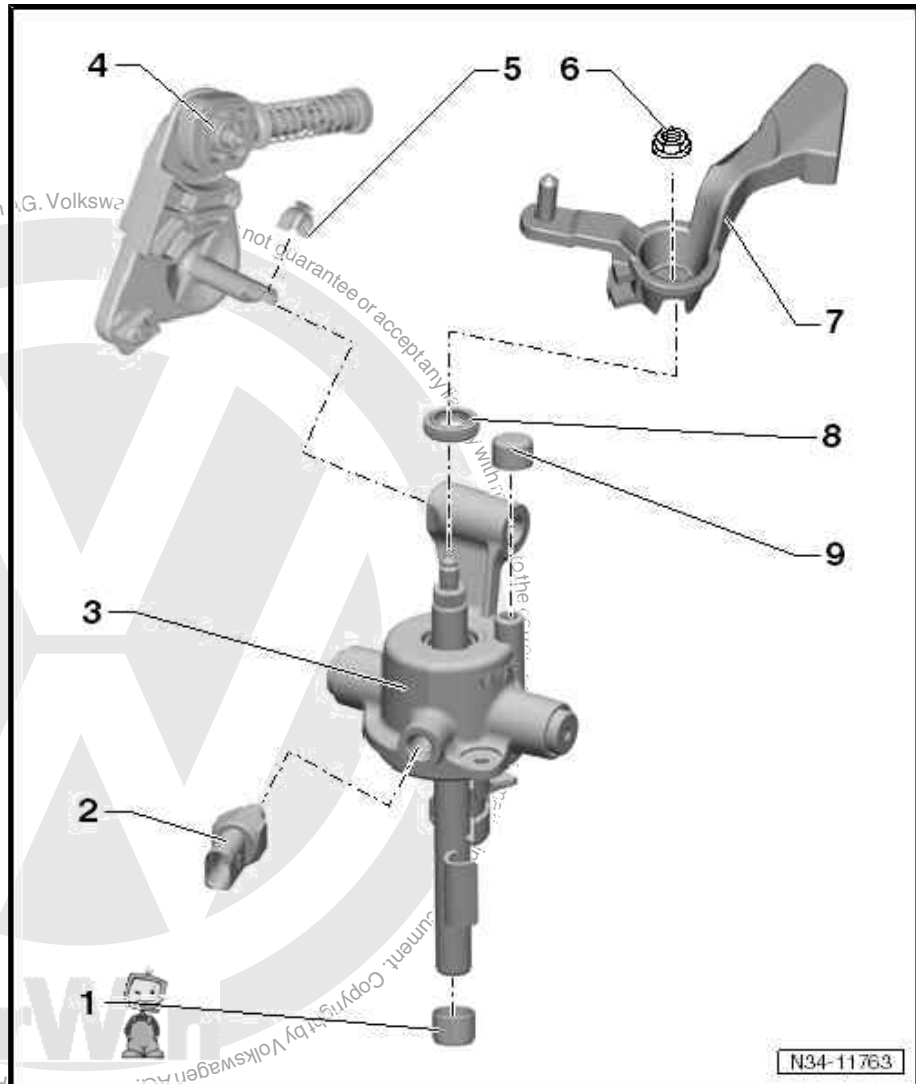

N34-11763



5.5 Assembly overview - shafts, differential, selector mechanism

1 - Gearbox housing

- With reverse shaft -arrow-
- It is not necessary to remove reverse shaft to allow for removal of reverse gear wheel
- Repairing gearbox housing ⇒ [page 131](#)
- Allocation ⇒ Electronic parts catalogue (ETKA)

2 - Selector unit

- (Selector shaft with selector shaft cover) ⇒ [page 118](#)
- Removing and installing with gearbox installed ⇒ [page 119](#)

3 - Bolt

- Self-locking
- Renew after removal
- 5 Nm and turn 90° further

4 - Gearbox neutral position sender - G701-

- Installed depending on version.
- Allocation ⇒ Electronic parts catalogue (ETKA)

5 - Bolt

- 6 Nm

6 - Selector mechanism

- (Selector forks)

7 - Input shaft

- Dismantling and assembling ⇒ [page 136](#)

8 - Output shaft

- Dismantling and assembling ⇒ [page 151](#)

9 - Differential

- Dismantling and assembling ⇒ [page 174](#)

10 - Thrust washer

11 - Needle bearing

12 - Reverse gear wheel

13 - Thrust washer

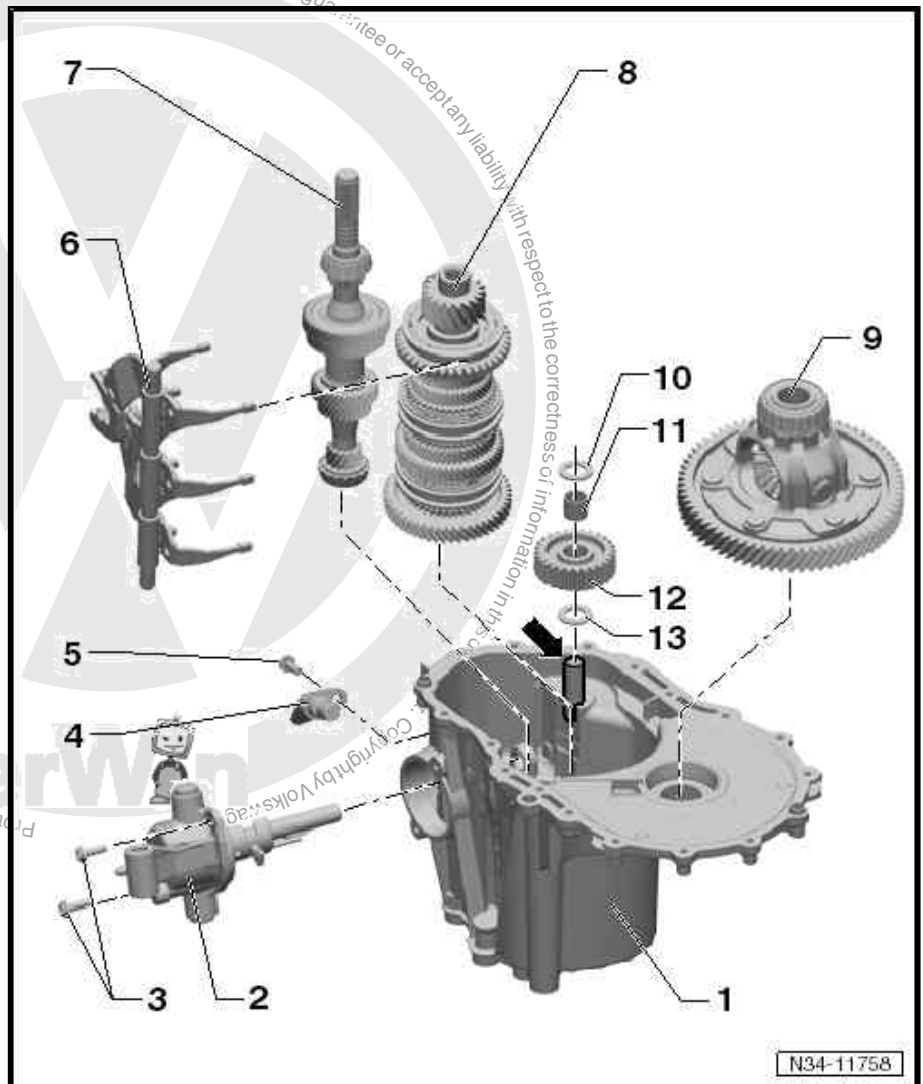

5.6 Removing and installing selector unit with gearbox installed

Special tools and workshop equipment required



- ◆ Torque wrench, VAS 6583-

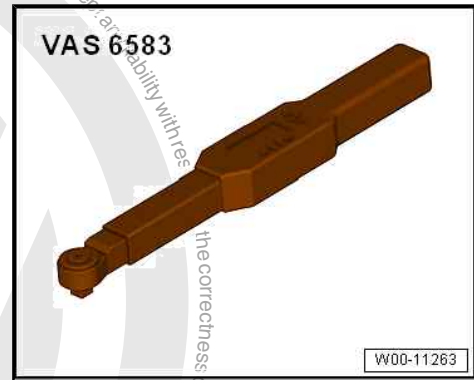

Removing

If installed above selector unit, remove following components:

- Complete air filter housing ⇒ Rep. gr. 24 ; Air filter; Removing and installing air filter housing .
- Battery and battery tray ⇒ Electrical system; Rep. gr. 27 ; Battery; Removing and installing battery tray .
- Gearbox in neutral position (arrows).

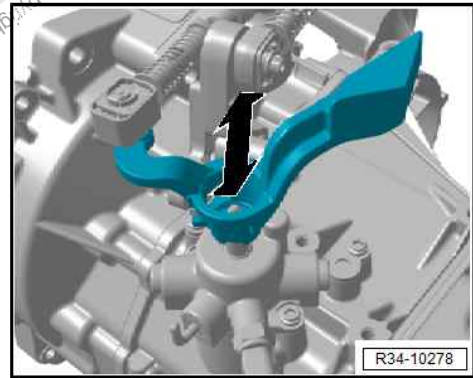

- Remove securing clip -1- for gear selector cable -2- from gear-box selector lever.
- Pull gear selector cable off pin.
- Remove relay lever -3- together with cable end-piece ⇒ [page 74](#) .
- Remove gearbox selector lever by unscrewing nut -4-.

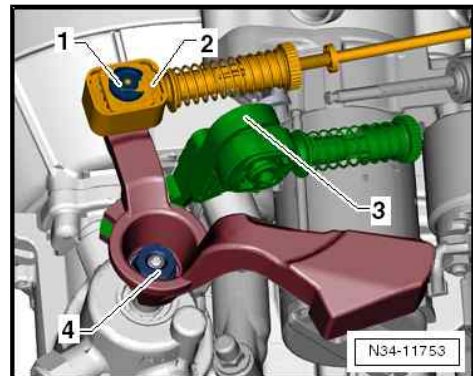

- Separate connectors:
- If present: pull off connector -1- from gearbox neutral position sender - G701- .
- Pull connector -2- off reversing light switch - F4- .
- Remove gearbox neutral position sender - G701- -1-.

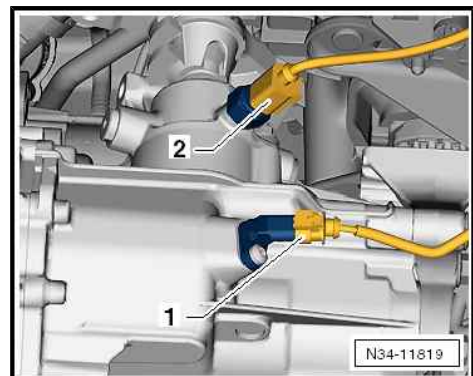



- Remove bolts -arrows-
- The adhesive effect of the sealant means that the selector unit needs to be pulled off forcibly. Be careful of the air conditioner lines where necessary.

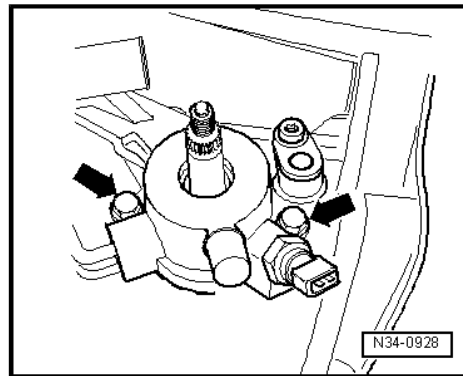

- Pull off selector unit -A-.

The selector unit is located just under the clutch slave cylinder -B- -arrow-.

The selector unit may come into contact with the clutch slave cylinder slightly.

- Pull off selector unit from relay lever mounting -1- and mounting for reversing light switch - F4- -2-.
- Clean all sealing surfaces.
- Cover gearbox.

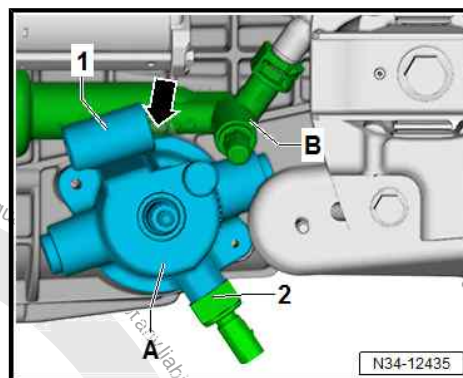

Installing

- The selector shaft is in the neutral position (shown here with the selector unit installed).
- The selector rods -A- of the gearbox are in neutral position.
- All sealing surfaces are cleaned.
- Apply sealant evenly at several points to the sealing surfaces of the selector unit.

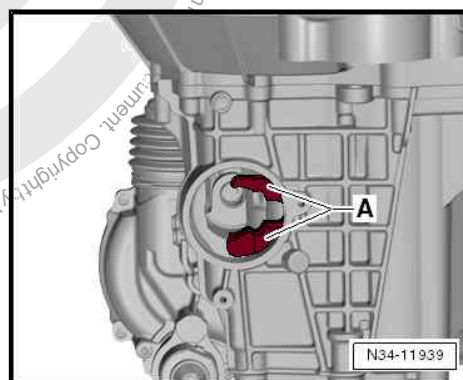
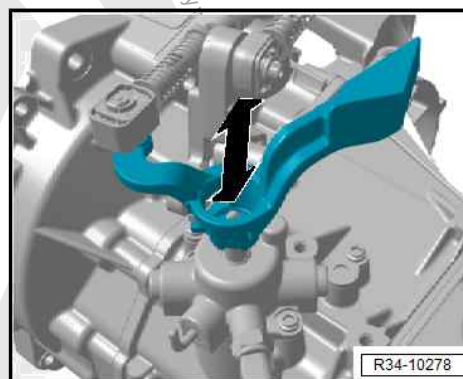



Installation position: The selector unit -A- is located just under the clutch slave cylinder -B- (-arrow-).

- Press the selector unit on the relay lever mounting -1- and the mounting for the reversing light switch - F4- -1-.

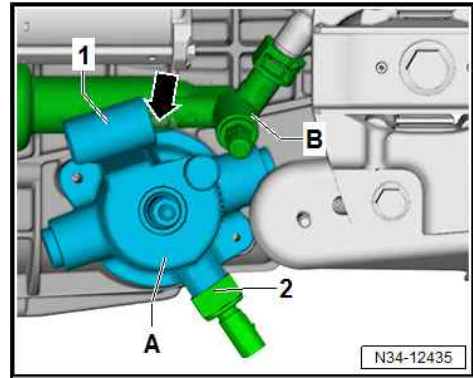

- Tighten selector unit with new bolts -arrows- => [page 119](#) .

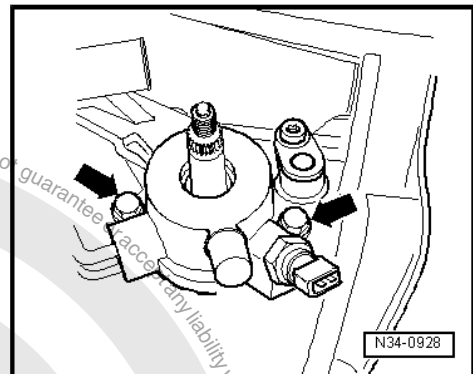

- If fitted, install gearbox neutral position sender - G701- -1- => [page 119](#) .
- Fit electrical connectors:
- If present: fit connector -1- to gearbox neutral position sender - G701- .
- Fit connector -2- to reversing light switch - F4- .
- Slightly pull on connector to ensure it is properly engaged.

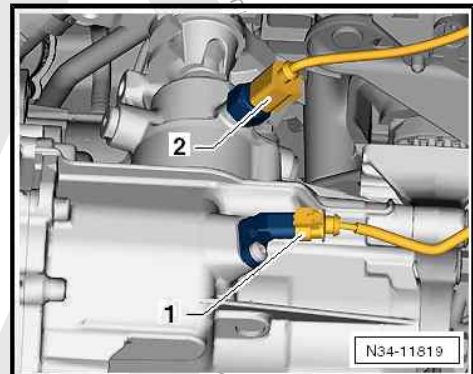



- Install gearbox selector lever and tighten hexagon nut -4- to specified torque ⇒ [page 118](#) .
- Install relay lever -3- together with cable end-piece ⇒ [page 74](#) .
- Spread a small amount of grease on pin of gearbox selector lever.

Allocate grease using ⇒ Electronic parts catalogue (ETKA) .

- Attach gear selector cable -2- to gearbox selector lever.
- Install new clip -1-.
- Adjust selector mechanism ⇒ [page 76](#) .
- If removed, install battery ⇒ Electrical system; Rep. gr. 27 ; Battery; Removing and installing battery .
- Connect battery and follow procedure after connecting battery ⇒ Electrical system; Rep. gr. 27 ; Disconnecting and connecting battery .
- If removed, assemble engine cover panel and air filter ⇒ Rep. gr. 24 ; Air filter, Removing and installing air filter housing .

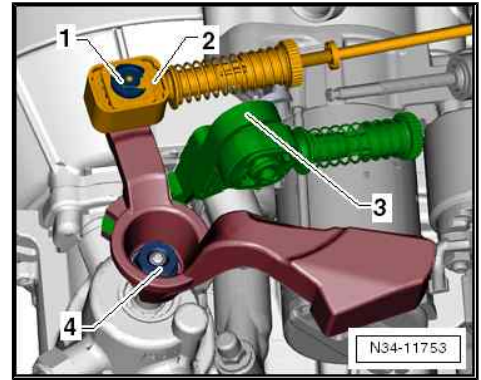

Specified torques

- ◆ Selector unit to gearbox ⇒ [page 119](#)

5.7 Renewing selector shaft sleeve

Special tools and workshop equipment required

- ◆ Drift - VW 222 A-

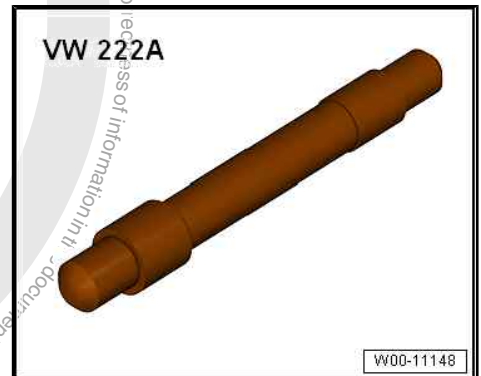

- ◆ Drift - 3264-

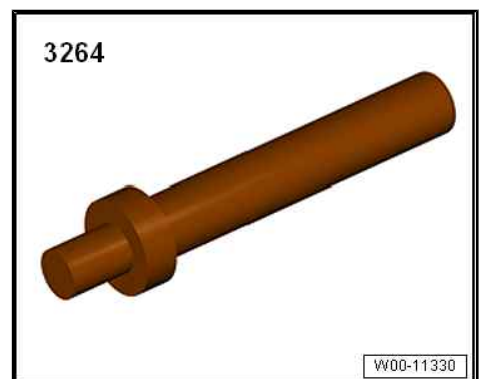



- Remove selector shaft with selector mechanism cover, input shaft, output shaft, differential and selector mechanism
⇒ [page 124](#) .

Driving out selector shaft sleeve -A-

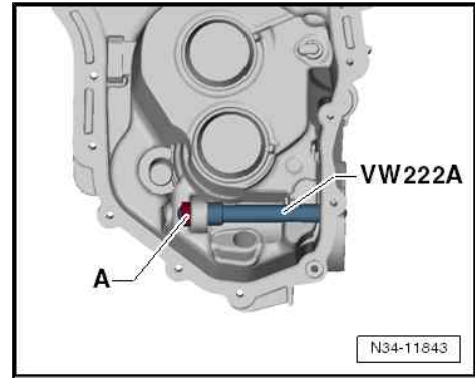

Driving in selector shaft sleeve -A- to stop

- Assembling gearbox ⇒ [page 124](#) .

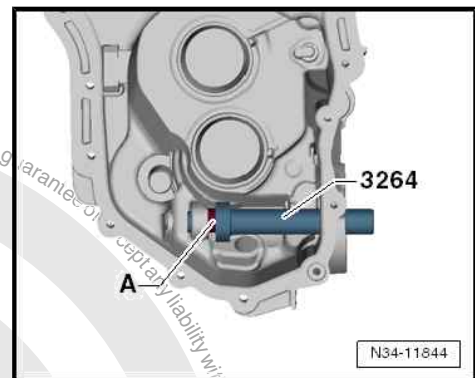

5.8 Dismantling and assembling gearbox

Removing and installing clutch housing, differential, selector shaft with selector mechanism cover, reverse gear wheel, input shaft, output shaft and selector forks

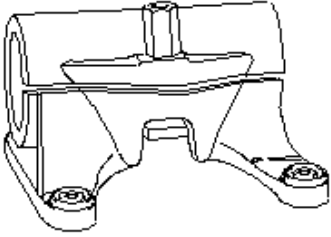
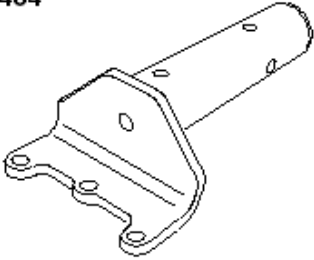
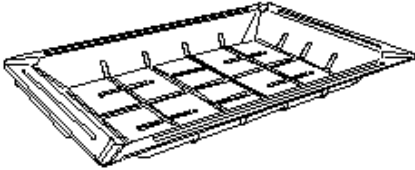
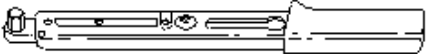

Special tools and workshop equipment required

<p>VW 313</p> 	<p>T10484</p> 
<p>VAS 6208</p> 	<p>V.A.G 1331</p> 
<p>Wolkswagen AG. Volkswagen AG does not guarantee or accept any liability with respect to the correctness of information in this document. Copyright by Volkswagen AG.</p>	<p>W34-10217</p>

- ◆ Support clamp - VW 313-
- ◆ Gearbox support - T10484-
- ◆ Torque wrench - V.A.G 1331-
- ◆ Drip tray - V.A.G 1306-
- ◆ or drip tray for workshop hoist - VAS 6208-
- ◆ Sealant
- ◆ Allocation ⇒ Electronic parts catalogue (ETKA)

Dismantling gearbox

- Secure gearbox on gearbox support ⇒ [page 133](#) .
- Place drip tray underneath.



- Remove clutch release lever -A- together with release bearing and guide sleeve -arrows-.
- Unscrew bolts securing clutch housing to gearbox housing.
- Remove clutch housing, if necessary carefully levering up all around along protruding housing flange and alternating between sides, being careful not to damage sealing surfaces.

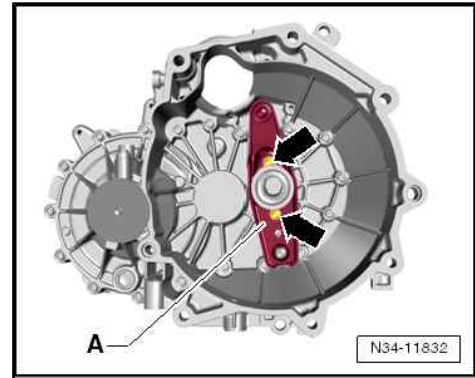

- Remove differential -A- from gearbox housing.

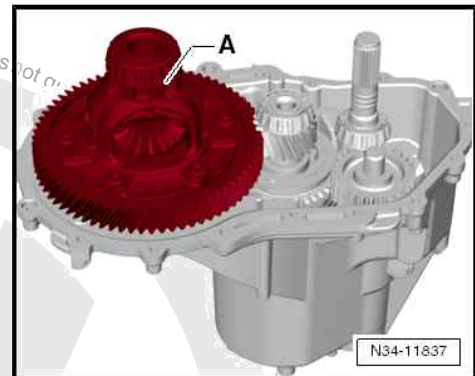

- If fitted, remove gearbox neutral position sender - G701 -arrow-.

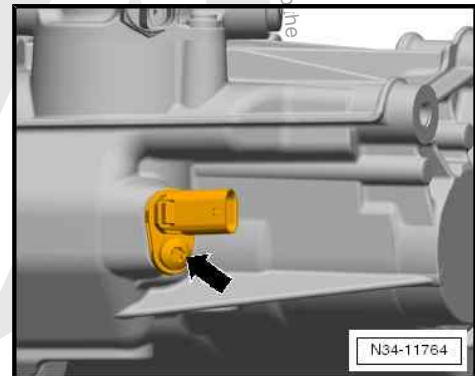

- Remove selector shaft with selector cover -A-. Place selector shaft in neutral. Then remove bolts -arrows- and pull selector shaft out of gearbox housing.

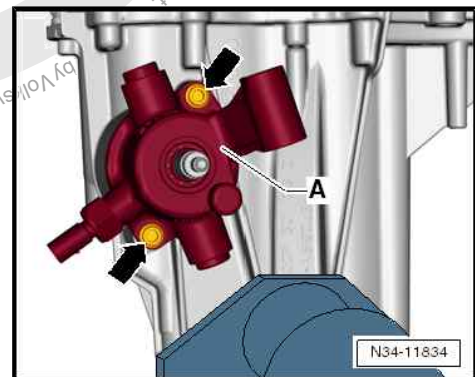



- One after other, remove thrust washer -1-, reverse gear wheel -2-, roller bearing -3- and thrust washer -4-.

i Note

To remove the reverse gear wheel, slightly lift the input shaft, and push it away from the reverse gear wheel.

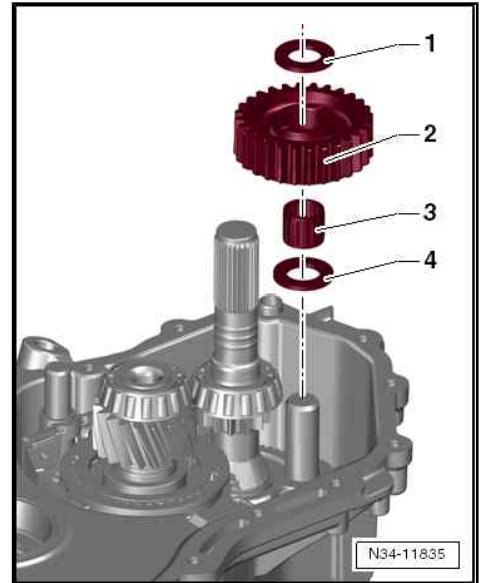

Proceed as follows to remove the input and output shafts together with selector forks from gearbox housing:

- Swivel gearbox housing in assembly stand as shown in illustration.
- Slightly pull out shaft -1- for selector forks.
- ◆ Hold the input shaft and selector forks with your right hand -2-.
- ◆ With your left hand, grasp the output shaft at the splines -3-, and pull it out.
- ◆ Then, hold output shaft in area -4- behind locking collar -arrow-.

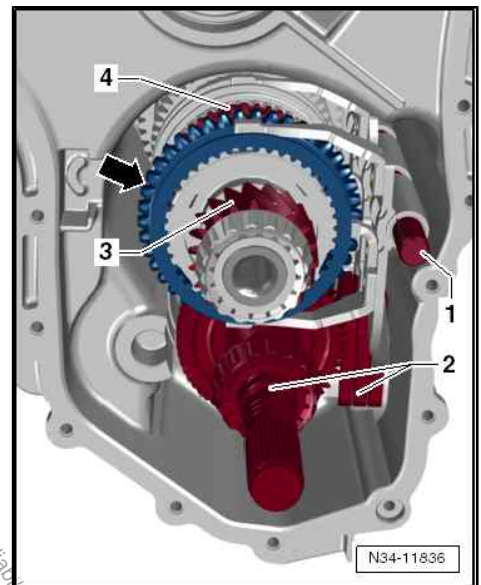

i Note

Do not press off the locking collar -arrow-. Otherwise, the locking pieces will be pushed out and might spring out uncontrolled.

Assembling gearbox

Push selector forks -A-, -B- and -C- onto shaft.

Installation position:

- Position selector fork for 1st and 2nd gears -A- below selector fork for 3rd and 4th gears -B-.
- 5th gear/reverse selector fork -C- must be positioned above selector fork for 3rd and 4th gears -B-.

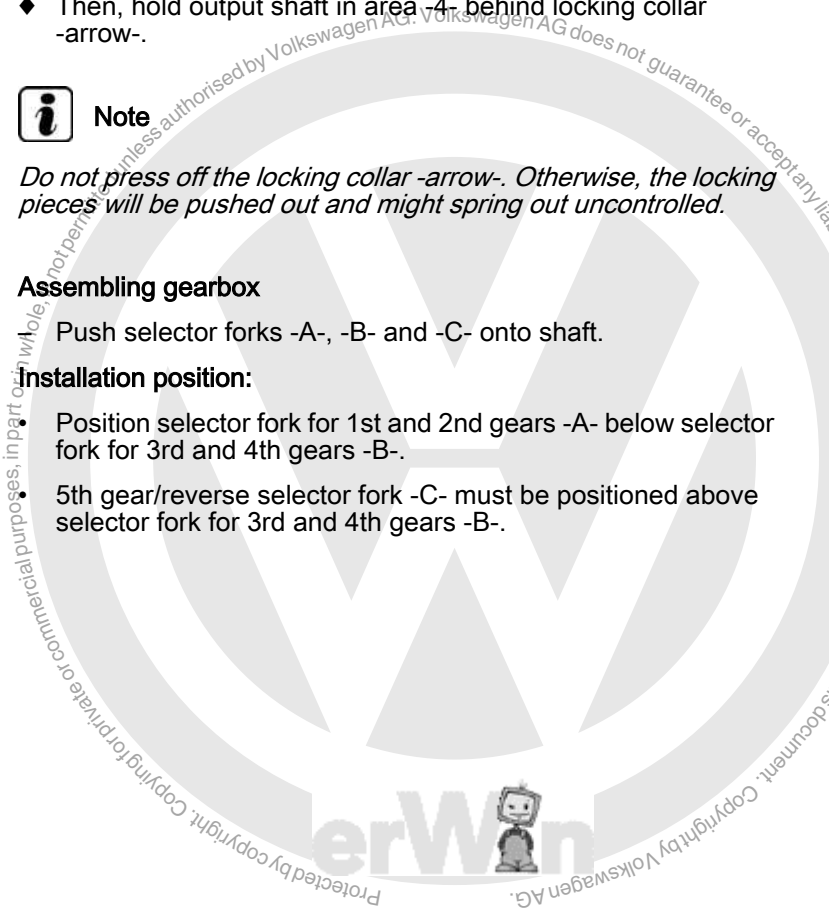
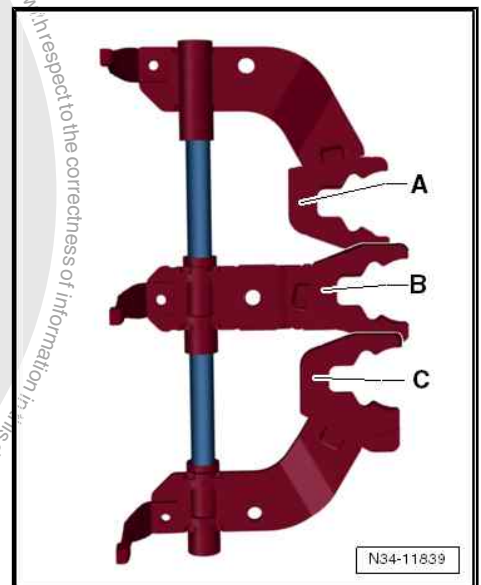



- Complete output shaft -A- and input shaft -B- with selector forks -C-.
- The selector forks are located in the locking collars -arrows-.

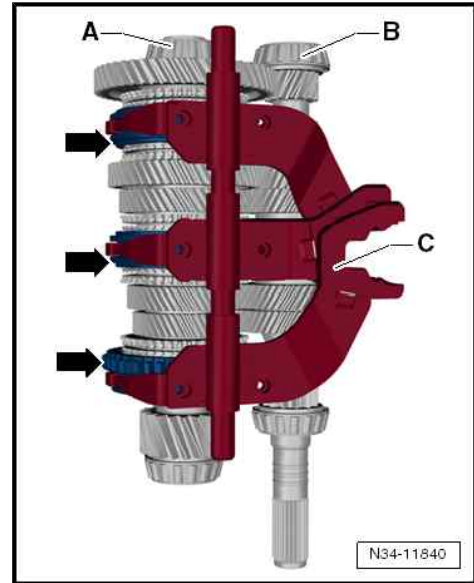

Proceed as follows to install the input and output shafts together with selector forks into gearbox housing:

- Swivel gearbox housing in assembly stand as shown in illustration.
- ◆ Hold the input shaft and selector forks with your right hand -2-.
- ◆ With your left hand, grasp the output shaft in area -4- behind locking collar -arrow-.



Note

Do not press off the locking collar -arrow-. Otherwise, the locking pieces will be pushed out and might spring out uncontrolled.

Then grasp the output shaft at the splines -3-.

- Bring gearbox housing in assembly stand back into vertical position.
- Push input shaft, output shaft and shaft -1- for selector forks into their seats.

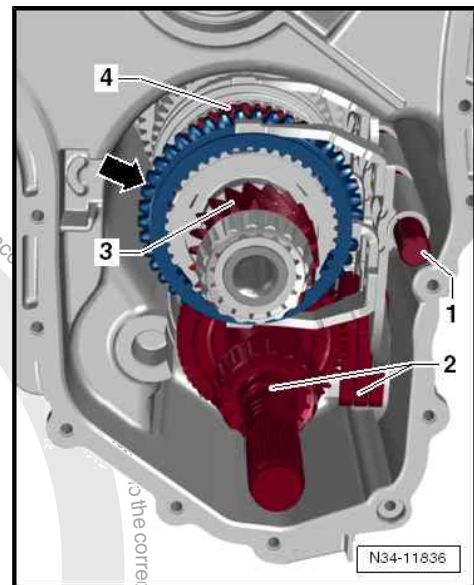



- One after other, fit thrust washer -1-, reverse gear wheel -2-, roller bearing -3- and thrust washer -4-.

Installation position of reverse gear wheel:

- ◆ Chamfer -arrow- faces towards gearbox housing.

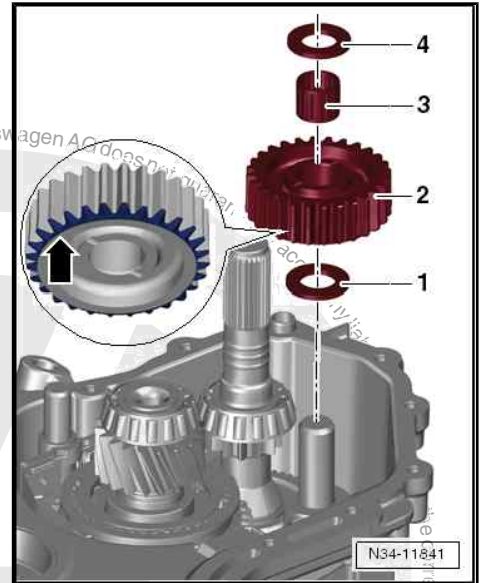

- Place selector plates in neutral.
- Apply sealant evenly to sealing surface of selector mechanism cover.
- Install selector shaft with selector mechanism cover -A-. Then, tighten bolts -arrows- to specified torque.

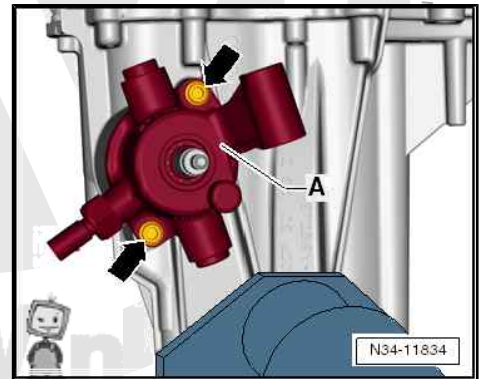

- Gearbox for vehicles with start/stop system: insert gearbox neutral position sender - G701- -arrow- and tighten securing bolt to specified torque.

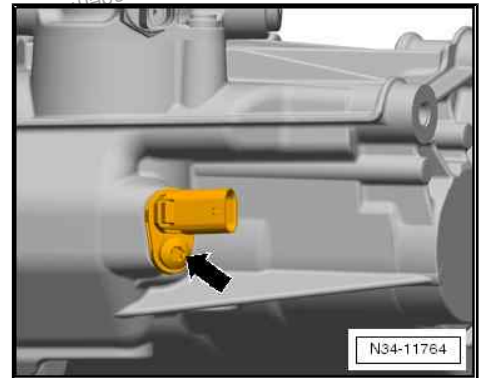

- Fit differential -A-.
- Apply sealant evenly to sealing surface for clutch housing.
- Secure clutch housing to gearbox housing.
- Install clutch release lever together with release bearing and guide sleeve => [page 51](#) .

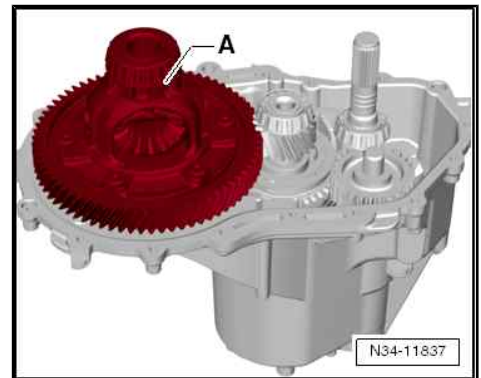



- Tighten oil drain plug -arrow-. (Shown here with gearbox installed.)

Specified torques

- ◆ => ["5.5 Assembly overview - shafts, differential, selector mechanism", page 119](#)
- ◆ Gearbox housing to clutch housing
=> ["5.3 Assembly overview - clutch housing", page 117](#) .

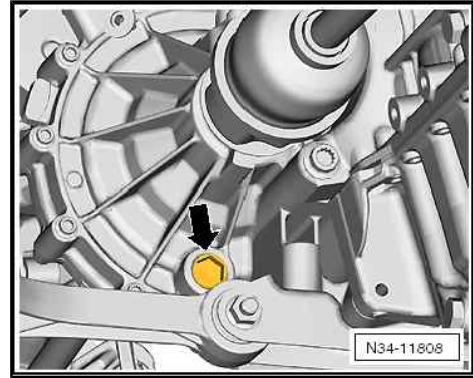



6 Gearbox housing, clutch housing

⇒ [“6.1 Assembly overview - gearbox housing and clutch housing”, page 131](#)

⇒ [“3.1 Removing and installing reverse shaft”, page 170](#)

6.1 Assembly overview - gearbox housing and clutch housing

1 - Gearbox housing

- If renewed: adjust input shaft, output shaft and differential
⇒ [page 185](#)

2 - Sleeve

- For selector shaft
- Renew after removal
⇒ [page 123](#)

3 - Dowel sleeve

- Qty. 2

4 - Tapered roller bearing outer race

- For input shaft
- Pulling out of and pressing into clutch housing
⇒ [page 136](#)
- If renewed: adjust input shaft ⇒ [page 144](#)

5 - Tapered roller bearing outer race

- For output shaft
- Pulling out of and pressing into clutch housing
⇒ [page 151](#)
- If replaced: Adjust output shaft ⇒ [page 165](#) .

6 - Tapered roller bearing outer race

- For output shaft
- Pulling out of clutch housing and pressing into clutch housing
⇒ [page 151](#)

- If replaced: Adjust output shaft ⇒ [page 165](#) .

7 - Shim

- For output shaft
- Adjustment overview ⇒ [page 185](#)

8 - Tapered roller bearing outer race

- For input shaft
- Pulling out of clutch housing and pressing into clutch housing ⇒ [page 136](#)
- If renewed: adjust input shaft ⇒ [page 185](#)

9 - Shim

- For input shaft
- Adjustment overview ⇒ [page 185](#)

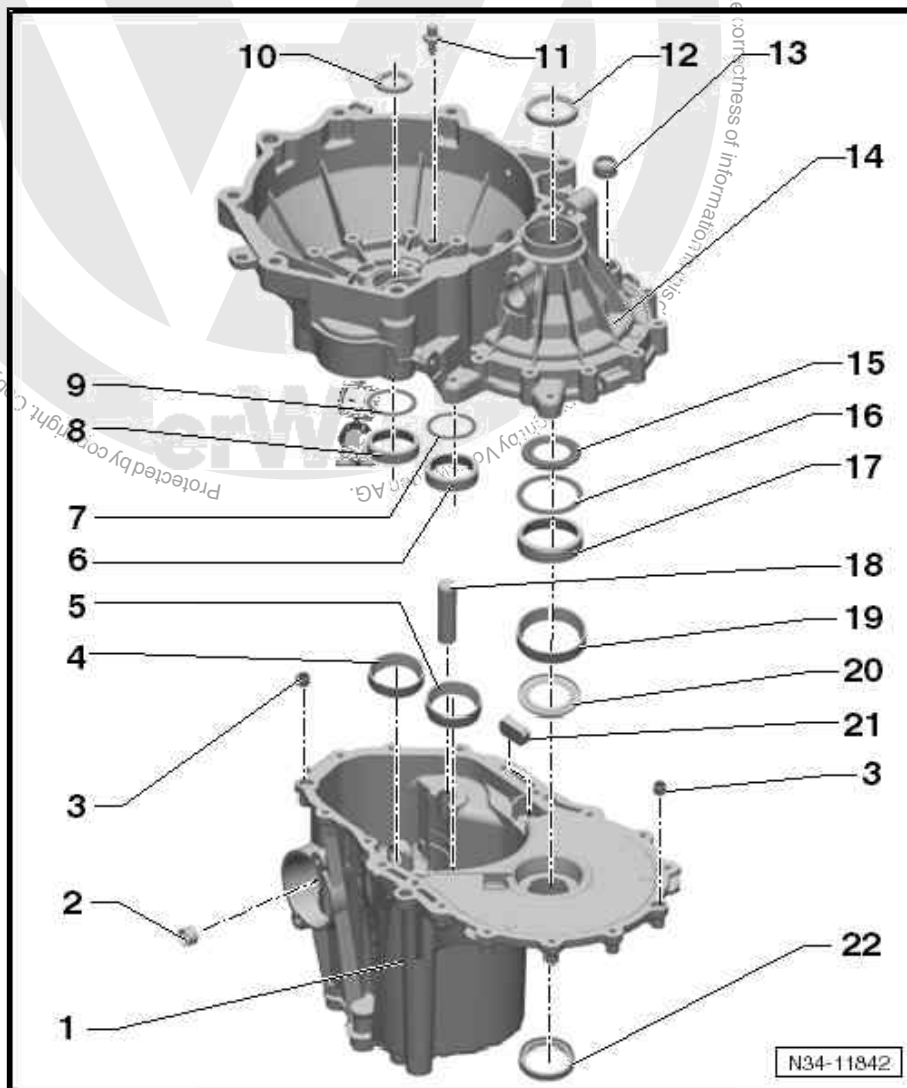



10 - Input shaft seal

- Renew after removal ⇒ [page 149](#)

11 - Ball-head pin

- Removing and installing ⇒ [page 24](#)

12 - Seal for right drive shaft

- Renew after removal
- Renewing with gearbox installed ⇒ [page 173](#)

13 - Oil drain plug

- 30 Nm

14 - Clutch housing

- If renewed: adjust input shaft, output shaft and differential ⇒ [page 185](#) .

15 - Baffle plate

16 - Shim

- For differential
- Adjustment overview ⇒ [page 185](#)

17 - Tapered roller bearing outer race

- For differential
- Pulling out of clutch housing and pressing into clutch housing ⇒ [page 174](#)
- If renewed, adjust differential ⇒ [page 182](#)

18 - Reverse shaft

- Renew after removal ⇒ [page 170](#)
- Is damaged during removal

19 - Tapered roller bearing outer race

- For differential
- Pulling out of and pressing into clutch housing ⇒ [page 174](#)
- If renewed, adjust differential ⇒ [page 182](#)

20 - Baffle plate

21 - Solenoid

- Held in place by housing joint surface

22 - Left drive shaft seal

- Renew after removal
- Renewing with gearbox installed ⇒ [page 171](#)

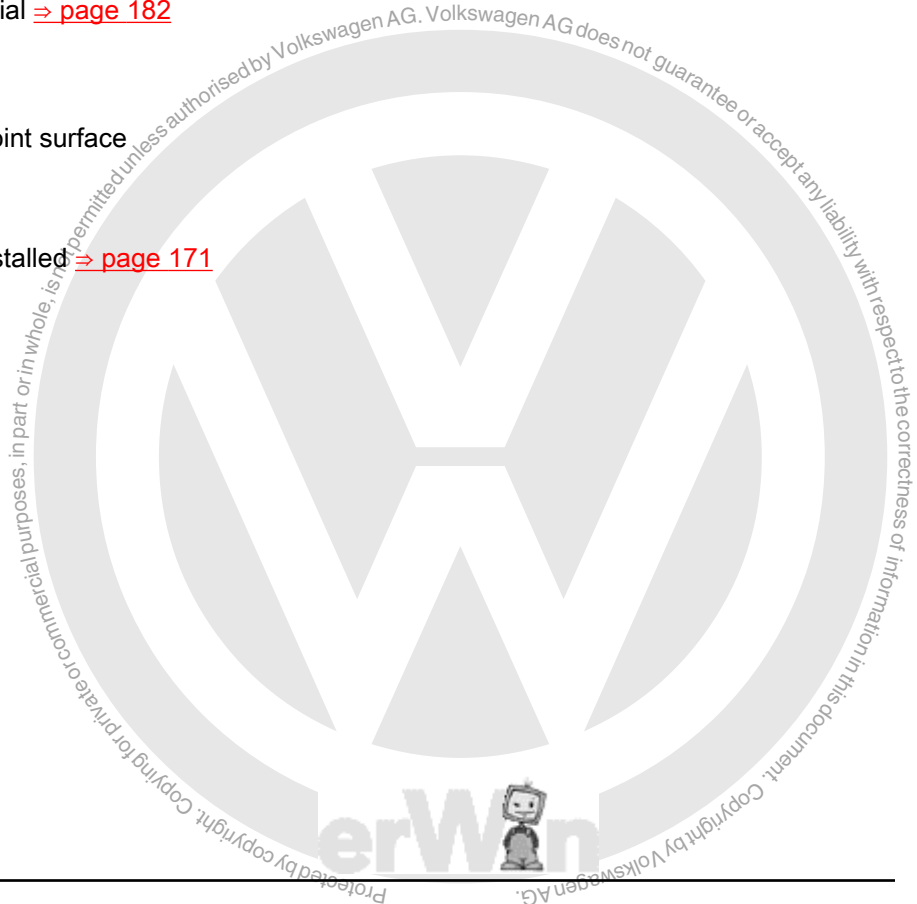



7 Securing to engine and gearbox support

Special tools and workshop equipment required

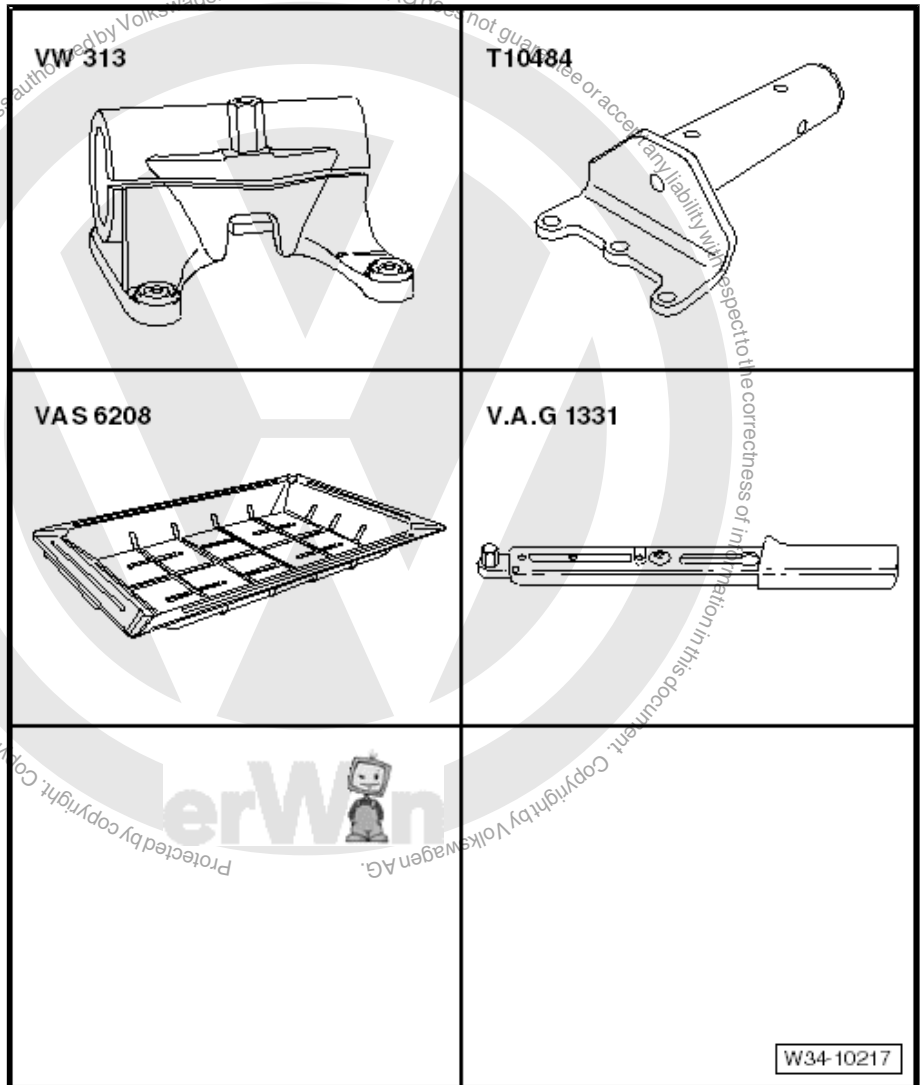

- ◆ Support clamp - VW 313-
- ◆ Gearbox support - T10484-
- ◆ Torque wrench - V.A.G 1331-
- ◆ Drip tray for workshop hoist - VAS 6208-
- Secure gearbox on gearbox support - T10484- -arrows-
- A- = bolts M10 x 35.

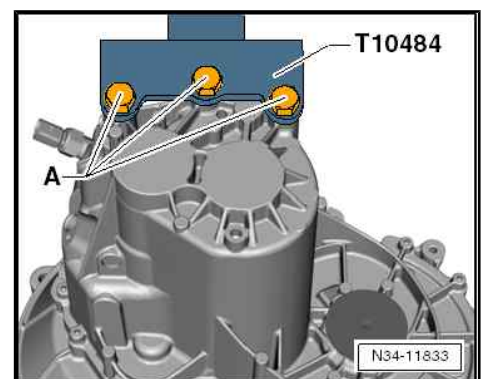



8 Gear oil

⇒ "8.1 Checking gear oil level", page 134

⇒ "8.2 Draining and filling gear oil", page 134

8.1 Checking gear oil level

The oil level in the gearbox can only be checked by completely draining the gear oil and then refilling it ⇒ page 134 .

8.2 Draining and filling gear oil

Special tools and workshop equipment required

- ◆ Torque wrench - VAS 6583-



- ◆ Commercially available hose (length of approx. 600 mm; external diameter: max. 22 mm)
- ◆ Funnel, commercially available
- ◆ Receptacle (capacity 2.0 l) with graduated scale

Preparing

Gear oil ⇒ Electronic parts catalogue (ETKA) .

- During subsequent work process, sealing plug -arrow- will be removed for filling gear oil.
- Clean area around sealing plug -arrow-.
- Cover pendulum support.

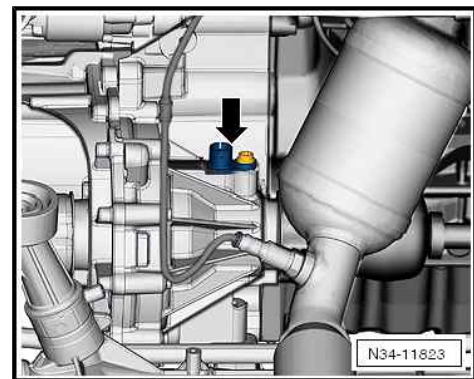

Drain gear oil -arrow- - -

Use a clean container with a scale and a capacity of approx. 2.0 l to catch the gear oil when draining.

- Tighten oil drain plug -arrow- to specified torque.

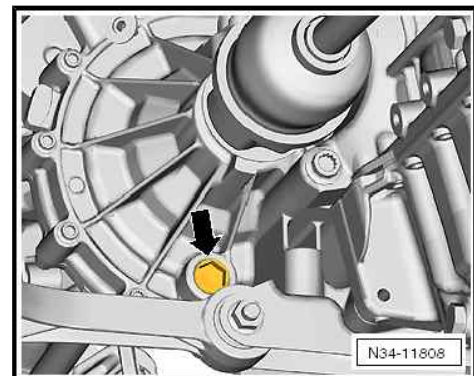



Fill with gear oil

- The oil drain plug is tightened to specified torque.

Gear oil ⇒ Electronic parts catalogue (ETKA)

Topping up gear oil in container ⇒ page 8

The gearbox oil is filled through the sealing plug hole -arrow-.

It is accessible from beneath vehicle.

- Remove sealing plug -arrow-.



Note

The area beneath the sealing plug -arrow- must be covered with a cloth.

- Use a commercially available hose (length of approx. 600 mm, external diameter: max. 22 mm), and a commercially available funnel for filling oil.

- Route hose -A- through engine compartment.

- Fit hose -A- into sealing plug hole, and fill gearbox with oil.

- Install sealing cap, and tighten securing bolt -arrow- to specified torque.

- If oil should get on gearbox and other components, remove it thoroughly.

Specified torques

Securing bolt for sealing plug	5 Nm +90°
--------------------------------	-----------

Oil drain plug	30 Nm
----------------	-------

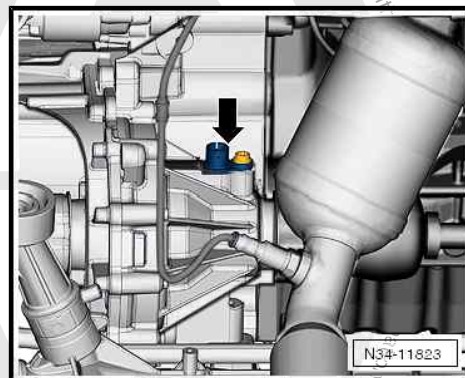
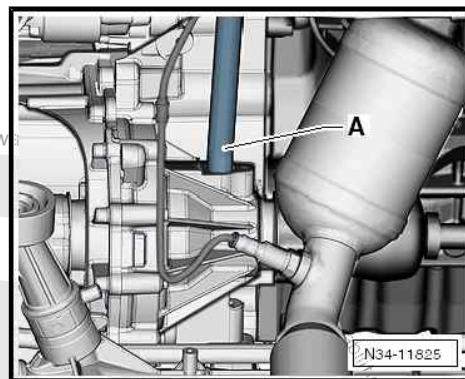
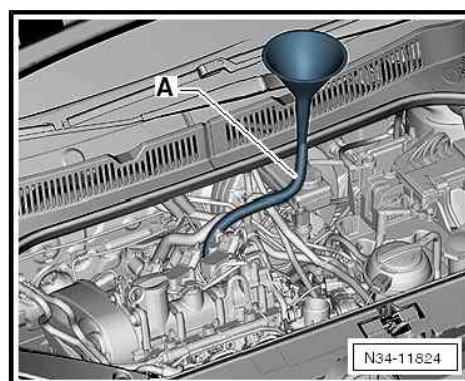
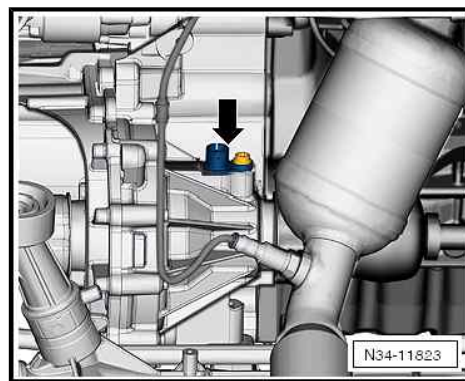

Protected by copyright. Copying for private or commercial purposes, in part or in whole, is not permitted unless authorised by Volkswagen AG. Volkswagen



35 – Gears, shafts

1 Input shaft

⇒ [“1.1 Assembly overview - input shaft”, page 136](#)

⇒ [“1.2 Dismantling and assembling input shaft”, page 138](#) .

⇒ [“1.3 Adjusting input shaft”, page 144](#) .

⇒ [“1.4 Renewing input shaft seal”, page 149](#) .

1.1 Assembly overview - input shaft



Note

- ◆ *When installing new gear wheels or a new input shaft, refer to technical data ⇒ [page 6](#) and the ⇒ *Electronic parts catalogue (ETKA)* .*
- ◆ *Heat gear wheels to max. 120°C.*
- ◆ *Always renew both tapered roller bearings together as a set.*
- ◆ *Install all bearings on input shaft with gear oil.*
- ◆ *Heat tapered roller bearing inner races to 100°C before installing.*





1 - Gearbox housing

2 - Tapered roller bearing outer race

- Removing ⇒ [page 141](#)
- Pressing in ⇒ [page 142](#) .

3 - Tapered roller bearing inner race

- Pressing off ⇒ [page 142](#)
- Pressing on ⇒ [page 142](#)

4 - Input shaft

- Adjusting ⇒ [page 144](#)

5 - Gear wheel for 3rd gear

- Pressing off ⇒ [page 143](#)
- Installation position: shoulder faces 4th gear ⇒ [page 143](#)
- Pressing on ⇒ [page 143](#)

6 - Retaining ring

- Renew after removal

7 - Retaining ring

- Renew after removal

8 - Gear wheel for 4th gear

- Press off together with gear wheel for 5th gear ⇒ [page 142](#)
- Installation position: shoulder faces 3rd gear ⇒ [page 143](#)
- Pressing on ⇒ [page 144](#)

9 - Gear wheel for 5th gear

- Press off together with gear wheel for 4th gear ⇒ [page 142](#)
- Installation position: higher shoulder faces towards 4th gear ⇒ [page 144](#)
- Pressing on ⇒ [page 144](#)

10 - Retaining ring

- Renew after removal

11 - Tapered roller bearing inner race

- Pressing off ⇒ [page 141](#)
- Pressing on ⇒ [page 141](#)

12 - Tapered roller bearing outer race

- Removing ⇒ [page 140](#)
- Pressing in ⇒ [page 141](#) .

13 - Shim

- Determining thickness ⇒ [page 144](#)

14 - Clutch housing

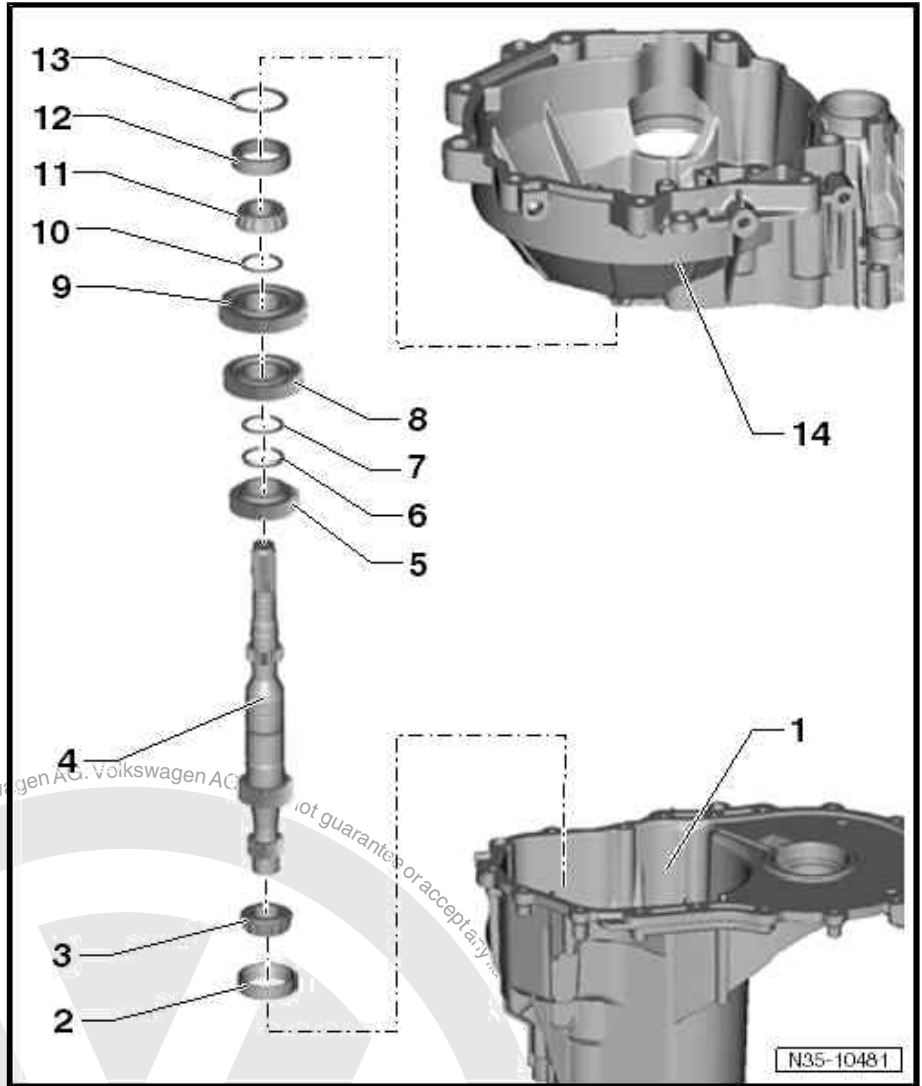



1.2 Dismantling and assembling input shaft

Special tools and workshop equipment required

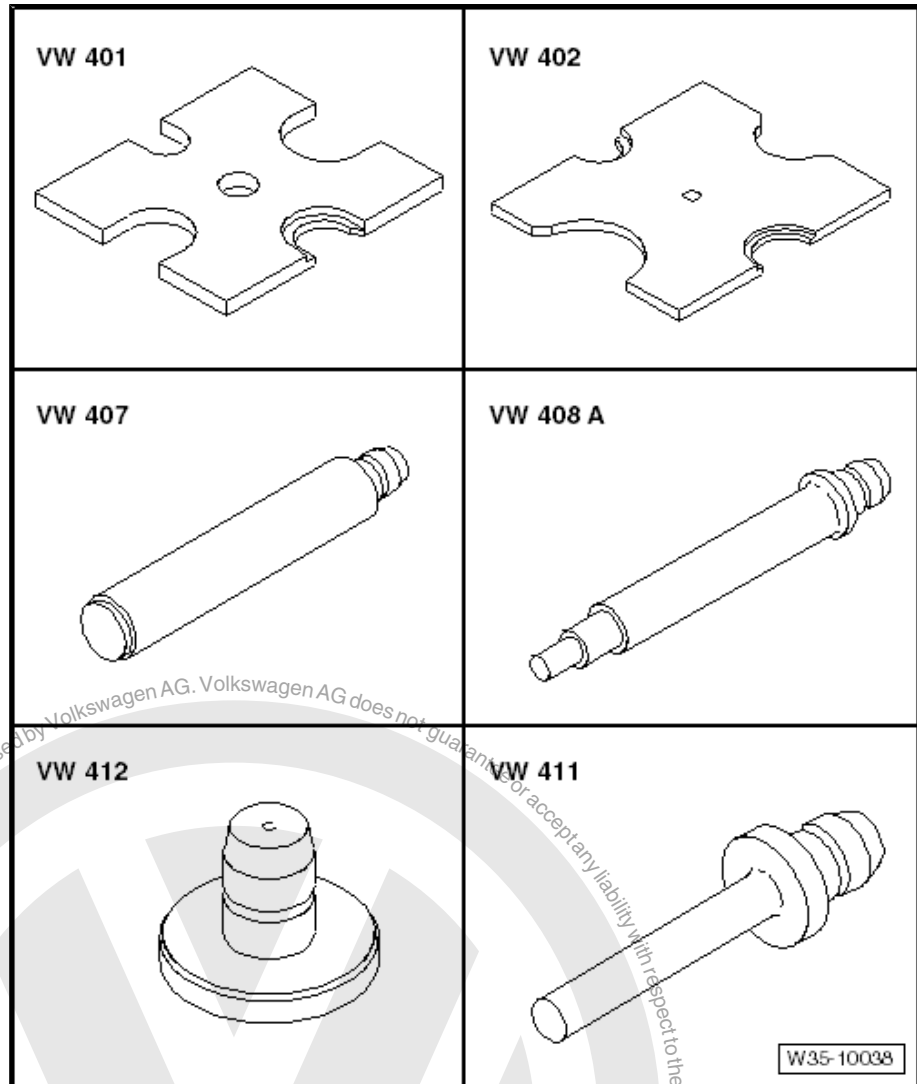

- ◆ Thrust plate - VW 401-
- ◆ Thrust plate - VW 402-
- ◆ Press tool - VW 407-
- ◆ Press tool - VW 408 A-
- ◆ Press tool - VW 411-
- ◆ Press tool - VW 412-

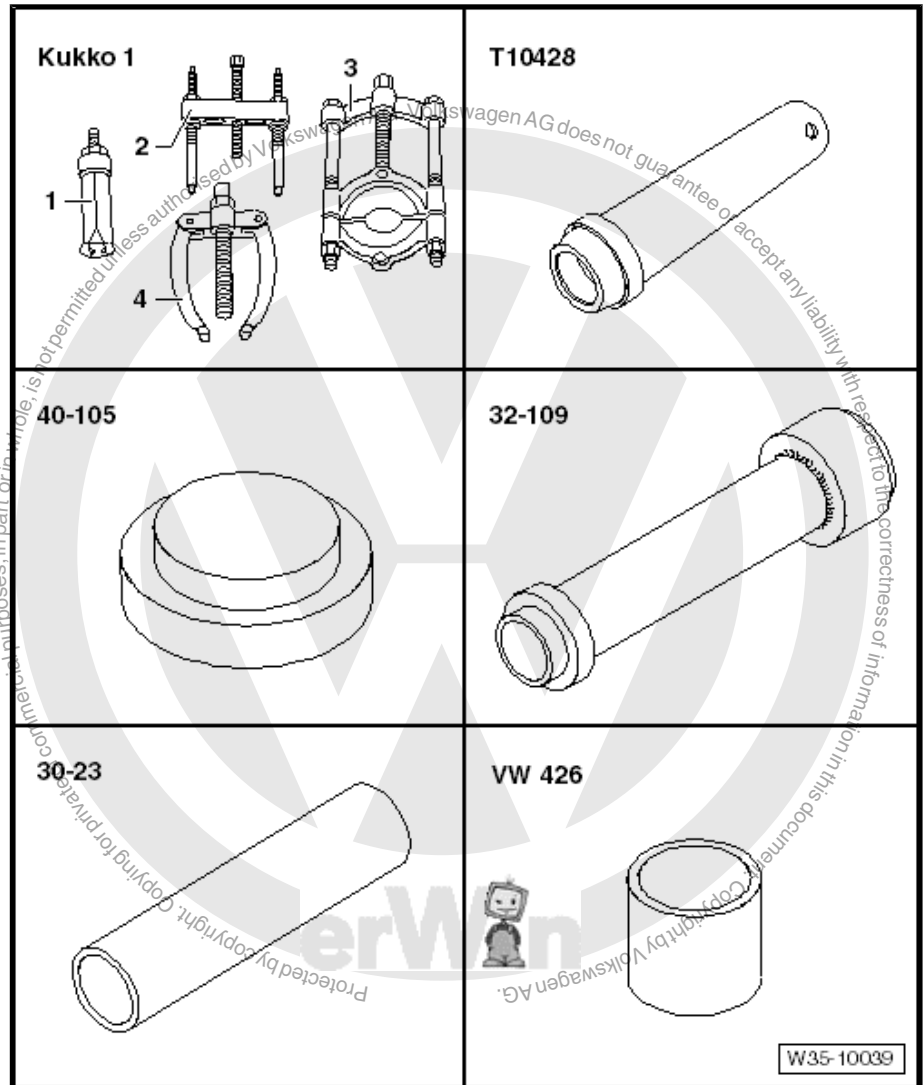

- ◆ Not applicable: -Kukko1-
- ◆ Press tool - T10428-
- ◆ Thrust plate - 40 - 105-
- ◆ Tube - 32 - 109-
- ◆ Extension - 30 - 23-
- ◆ Tube - VW 426-

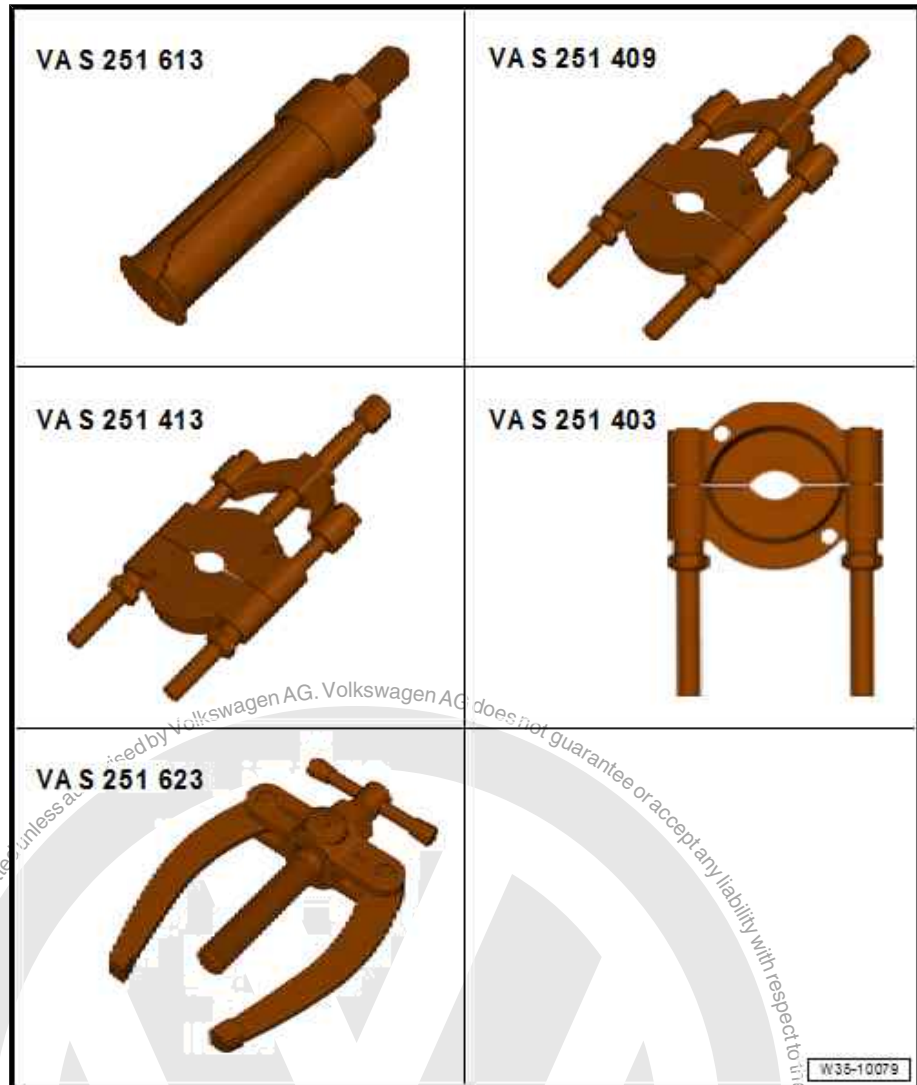

- ◆ Internal puller - VAS 251 613- , or e.g. -Kukko 21/6-
- ◆ Splitter - VAS 251 409- or e.g. splitter - Kukko 17/1-
- ◆ Splitter - VAS 251 413- or e.g. splitter - Kukko 17/3-
- ◆ Splitter - VAS 251 403- or e.g. splitter - Kukko 15/2-
- ◆ Counter support - VAS 251 623- , or e.g. counter support - Kukko 22/2-

Pulling tapered roller bearing outer race out of clutch housing

A - Counter support - VAS 251 623- or counter support , e.g. - Kukko 22/2-

B - Internal puller - VAS 251 613- , or e.g. internal puller 37...46 mm - Kukko 21/6-

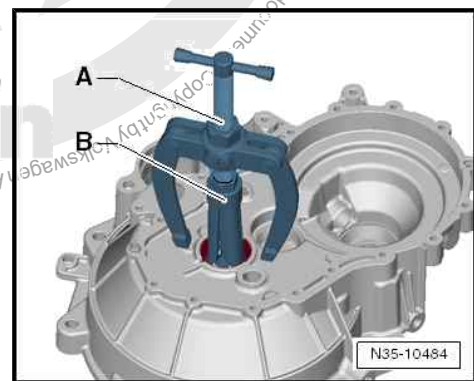



Pressing tapered roller bearing outer race into clutch housing

- Insert shim.

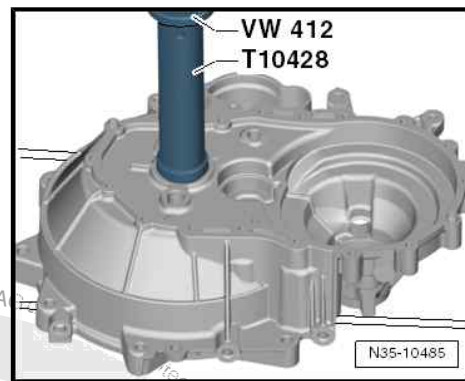

Press off tapered roller bearing inner race on side facing clutch housing

- A - Splitter - VAS 251 409- or splitter 12 ... 75 mm , e.g. -Kukko 17/1-

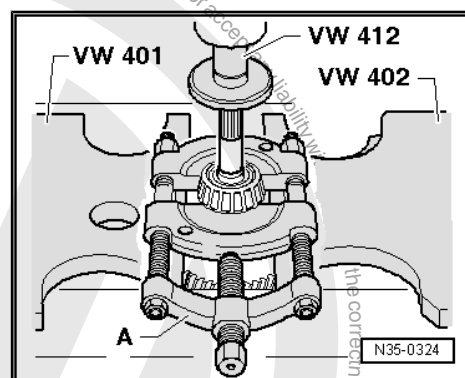

Press on tapered roller bearing inner race on side facing clutch housing

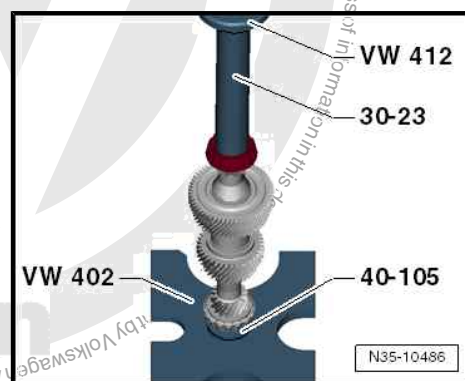

Pulling outer race for tapered roller bearing out of gearbox housing

- A - Counter support - VAS 251 623- or counter support , e.g. - Kukko 22/2-
- B - Splitter - VAS 251 413- or splitter 25 ... 155 mm , e.g. -Kukko 17/3-
- C - Internal puller - VAS 251 613- , or e.g. internal puller 37...46 mm - Kukko 21/6-

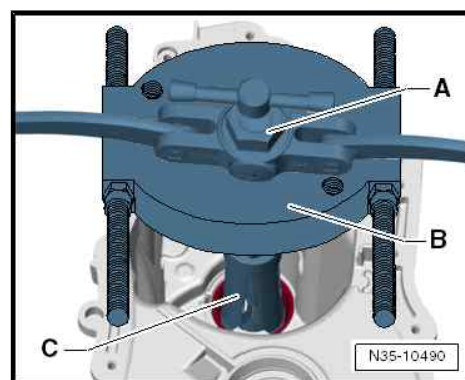



Pressing tapered roller bearing outer race into gearbox housing

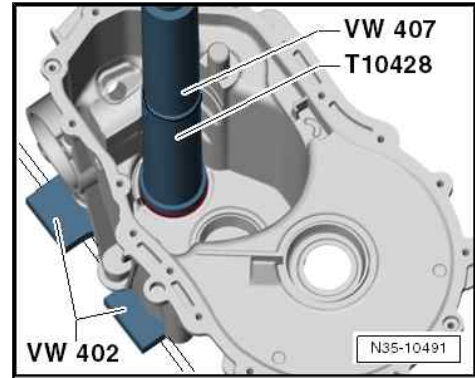

Pressing off tapered roller bearing inner race on side facing towards gearbox housing

A - Splitter - VAS 251 409- or splitter 12 ... 75 mm , e.g. -Kukko 17/1-

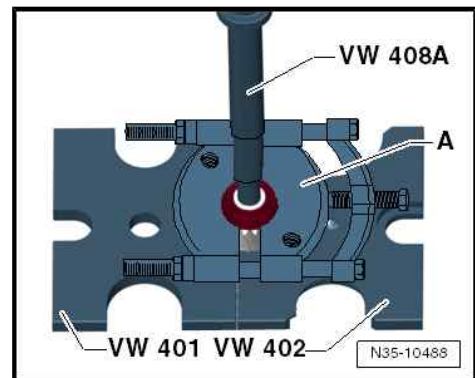

Press on tapered roller bearing inner race on side facing gearbox housing

Dismantling input shaft



Note

Pressing off the tapered roller bearing inner race for bearing the input shaft in the clutch housing => [page 141](#)

- Remove retaining ring.

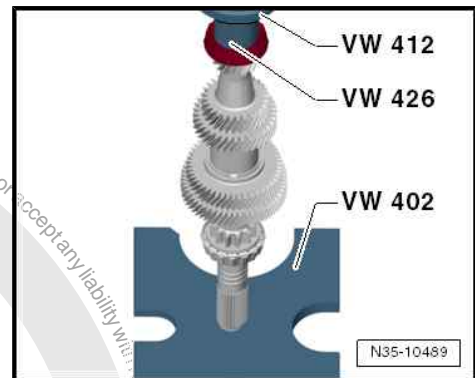

Pressing off gear wheel for 5th gear together with gear wheel for 4th gear

A - Splitter - VAS 251 403- or splitter 30 ... 120 mm , e.g. -Kukko 15/2-

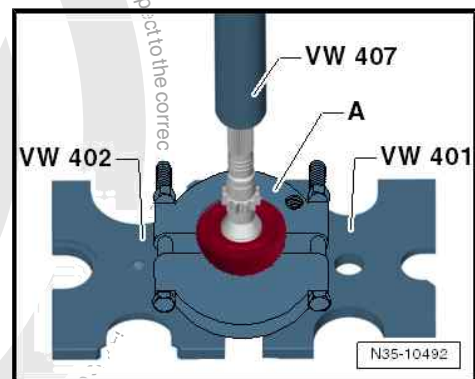



- Remove retaining rings -arrows-.

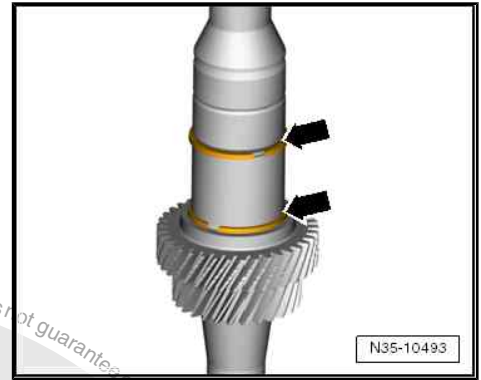

**Pressing off gear wheel for 3rd gear
 Assembling input shaft**

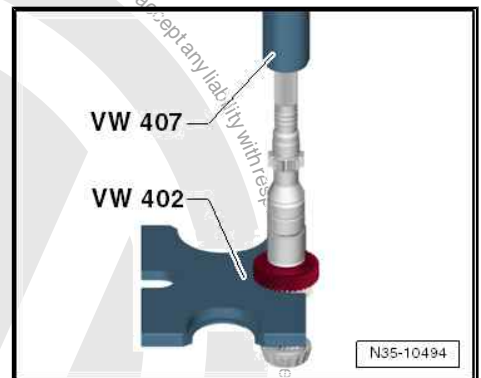

Installation position of 3rd gear and 4th gear

Shoulders -arrow- of gear wheels for 3rd gear -A- and 4th gear -B- face towards each other.

They are secured by means of retaining rings -1- and -2-.

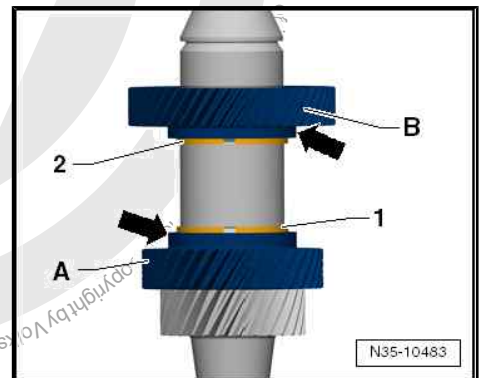

Pressing on gear wheel for 3rd gear

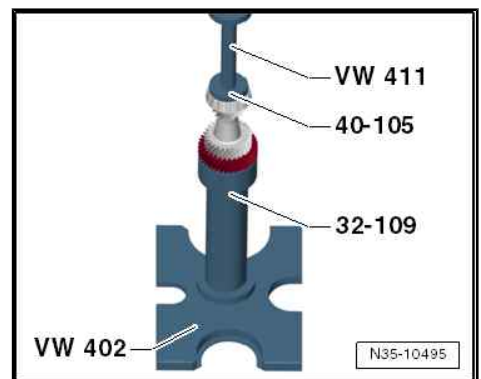



- Insert new retaining rings -arrows-.

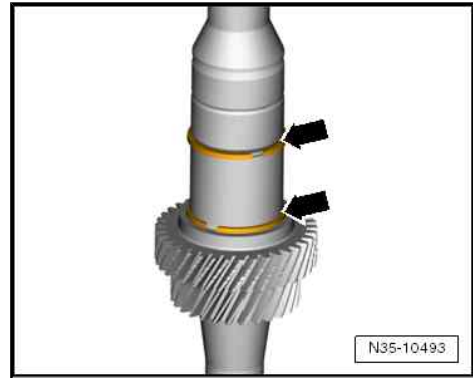

Pressing on gear wheel for 4th gear

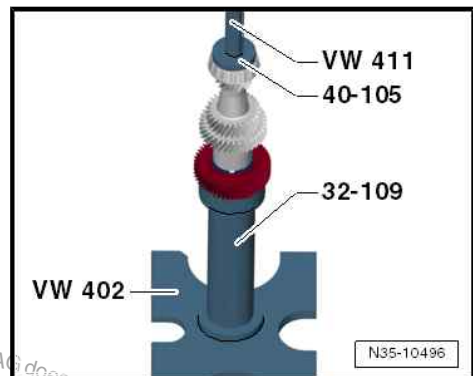

Installation position of 5th gear wheel

Higher shoulder -arrow- faces towards gear wheel for 4th gear.

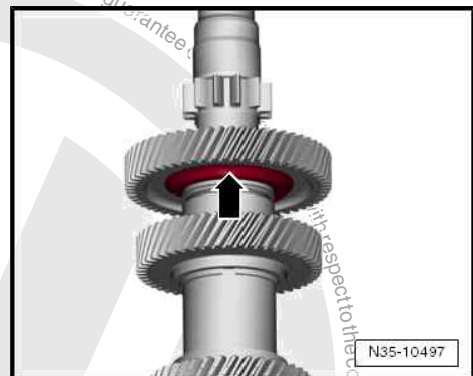

Pressing on gear wheel for 5th gear

- Fit retaining ring.



Note

Press on tapered roller bearing inner race for bearing in clutch housing => [page 141](#).

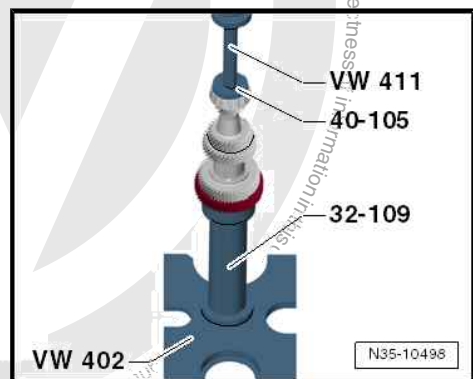

1.3 Adjusting input shaft

(Determining input shaft shim)

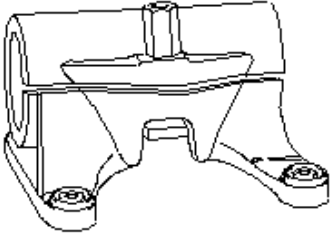
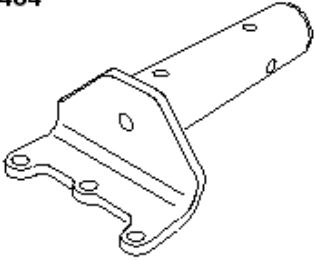
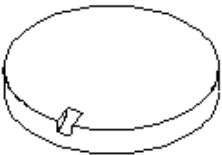
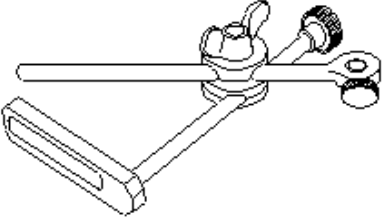
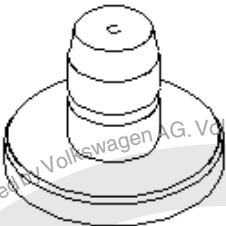
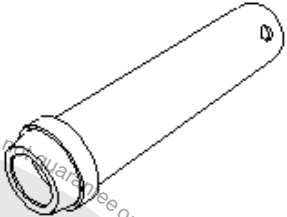

Special tools and workshop equipment required

<p>VW 313</p> 	<p>T10484</p> 
<p>VW 385/17</p> 	<p>VW 387</p> 
<p>VW 412</p> 	<p>T10428</p>  <p style="text-align: right;">W35-10040</p>

- ◆ Support clamp - VW 313-
- ◆ Gearbox support - T10484-
- ◆ End dimension plate - VW 385/17-
- ◆ Universal dial gauge holder - VW 387-
- ◆ Press tool - VW 412-
- ◆ Press tool - T10428-
- ◆ Torque wrench - V.A.G 1331-
- ◆ Dial gauge - VAS 6080A-
- ◆ 30 mm dial gauge extension



- ◆ Internal puller - VAS 251 613- , or internal puller , e.g. -Kukko 21/6-



- ◆ Counter support - VAS 251 623- or counter support , e.g. - Kukko 22/2-



It is necessary to readjust the input shaft only when the following components are renewed:

- ◆ Gearbox housing
- ◆ Clutch housing
- ◆ Input shaft

or the

- ◆ Tapered roller bearing

Adjustment overview ⇒ [page 185](#)

Requirement:

- Sealing surfaces of clutch and gearbox housings must be free of sealant .
- Both inner races for tapered roller bearings are pressed onto input shaft ⇒ [page 142](#) and ⇒ [page 141](#) .
- Tapered roller bearing outer race is pressed into gearbox housing ⇒ [page 142](#) .
- Press tapered roller bearing outer race without shim into gearbox housing to stop.
- Install input shaft in gearbox housing and set clutch housing in place. Tighten hexagon bolts to specified torque ⇒ [Item 3 \(page 117\)](#) .

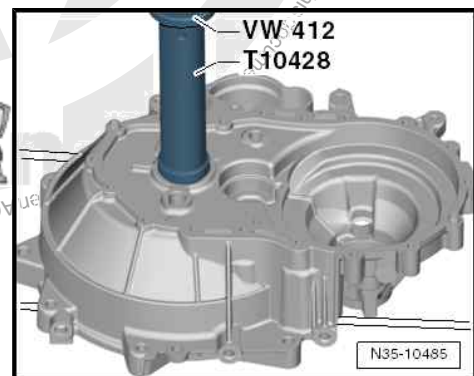



- Fit measuring appliance and dial gauge in clutch housing.
- Before taking any measurements, rotate input shaft to allow bearings to settle. Set dial gauge to "0" with 1 mm preload.

i Note

This step must be repeated for each subsequent measurement, or the dial gauge will not return to the starting position.

- Pull input shaft in direction of dial gauge.
- Read and note clearance indicated on dial gauge (example 0.930).
- Determine thickness of shim according to table; (e.g. 0.930); refer to ⇒ Electronic parts catalogue (ETKA) for part numbers.

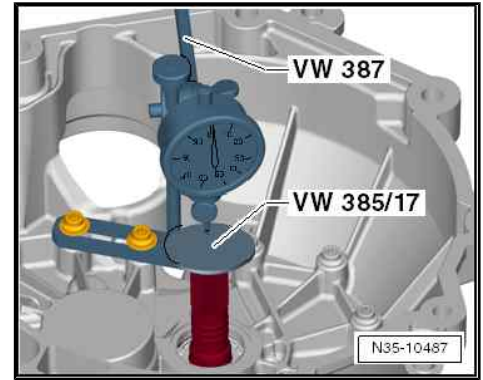



Removing gearbox housing, and pulling tapered roller bearing outer race out of clutch housing

A - Counter support - VAS 251 623- or counter support , e.g. - Kukko 22/2-

B - Internal puller - VAS 251 613- , or e.g. internal puller 37...46 mm - Kukko 21/6-

- Fit gearbox housing, and tighten new hexagon bolts to specified torque ⇒ [Item 3 \(page 117\)](#) .

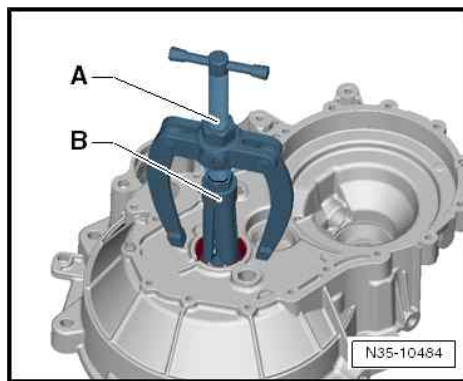

Table of shims

Bearing play	Shim
Measured value (mm)	Thickness (mm)
0.800 to 0.824	0.650
0.825 to 0.849	0.675
0.850 to 0.874	0.700
0.875 to 0.899	0.725
0.900 to 0.924	0.750
0.925 to 0.949	0.775
0.950 to 0.974	0.800

Bearing play	Shim
Measured value (mm)	Thickness (mm)
0.975 to 0.999	0.825
1.000 to 1.024	0.850
1.025 to 1.049	0.875
1.050 to 1.074	0.900
1.075 to 1.099	0.925
1.100 to 1.124	0.950

Bearing play	Shim
Measured value (mm)	Thickness (mm)
1.125 to 1.149	0.975
1.150 to 1.174	1.000
1.175 to 1.199	1.025
1.200 to 1.224	1.050
1.225 to 1.249	1.075

Bearing play	Shim
Measured value (mm)	Thickness (mm)
1.250 to 1.274	1.100
1.275 to 1.299	1.125
1.300 to 1.324	1.150
1.325 to 1.349	1.175
1.350 to 1.347	1.200



Bearing play	Shim
Measured value (mm)	Thickness (mm)
1.375 to 1.399	1.225
1.400 to 1.424	1.250
1.425 to 1.449	1.275
1.450 to 1.474	1.300
1.475 to 1.499	1.325
1.500 to 1.524	1.350

Carrying out check measurement

- Set up measuring appliance and dial gauge.
- Rotate input shaft so that tapered roller bearings settle.
- Pull input shaft in direction of dial gauge.
- Bearing play should be min. 0.140 ... max. 0.184 mm.

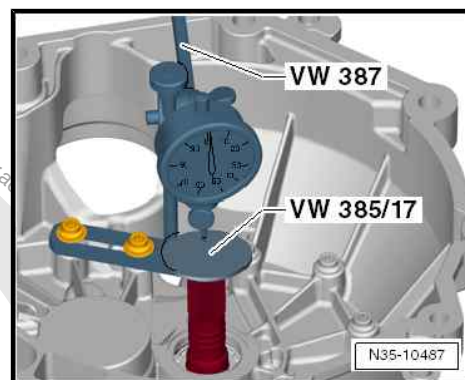

1.4 Renewing input shaft seal

Special tools and workshop equipment required

- ◆ Removal tool - T20143/2-

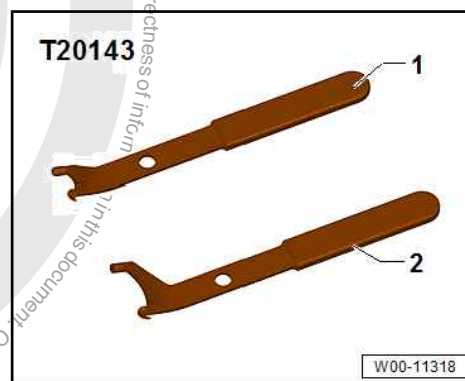

- ◆ Press tool - T40008-



- ◆ Sealing grease
- ◆ Allocate grease using ⇒ Electronic parts catalogue (ETKA) .
- Remove manual gearbox.



- Remove clutch release lever together with release bearing and guide sleeve => [page 24](#) .

Levering out input shaft seal



Note

Do not damage oil seal running surface on input shaft.

- Half-fill space between sealing lip and dust lip of new seal with sealing grease .
- Lightly moisten outer circumference of oil seal with gear oil.

Driving in input shaft oil seal flush

- Install clutch release lever together with release bearing and guide sleeve => [page 24](#) .
- Install manual gearbox:

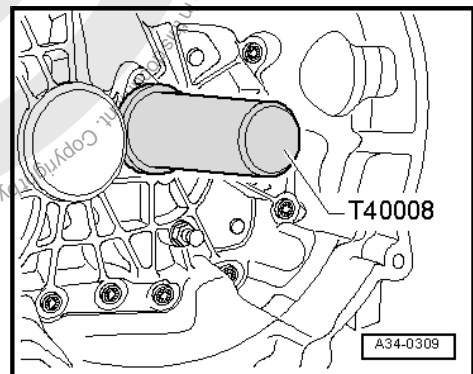
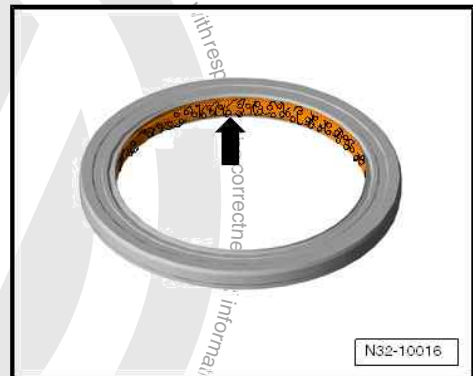
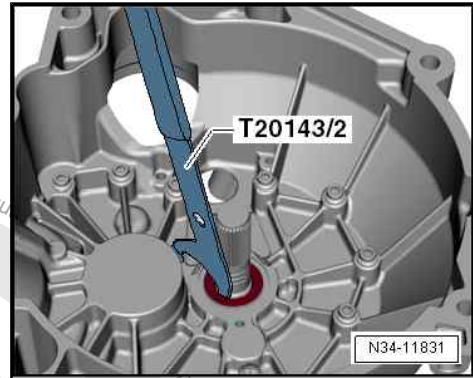



2 Output shaft

⇒ ["2.1 Assembly overview - output shaft", page 151](#)

⇒ ["2.2 Dismantling and assembling output shaft", page 154](#)

⇒ ["2.3 Adjusting output shaft", page 165](#)

2.1 Assembly overview - output shaft



Note

- ◆ When installing new gear wheels or a new output shaft, consult technical data ⇒ [page 6](#) and ⇒ *Electronic parts catalogue (ETKA)*.
- ◆ Heat gear wheels to max. 120°C.
- ◆ Install all bearings, synchromeshed gears and synchro-rings on output shaft with gear oil.
- ◆ Always renew both tapered roller bearings together as a set.
- ◆ Heat tapered roller bearing inner races to 100°C before installing.
- ◆ Do not interchange synchro-rings. When reusing always fit to the original gear.

1 - Clutch housing

- Various diameters of bearing seat for tapered roller bearing outer race ⇒ [page 157](#)

2 - Shim

- Determining thickness ⇒ [page 144](#)

3 - Tapered roller bearing outer race

- Removing ⇒ [page 157](#)
- Distinguishing ⇒ [page 157](#)
- Diameter of bearing seat in clutch housing = 51 mm, pressing in ⇒ [page 158](#)
- Diameter of bearing seat in clutch housing = 56 mm, pressing in ⇒ [page 158](#)

4 - Tapered roller bearing inner race

- Diameter according to tapered roller bearing outer race
- Allocation ⇒ *Electronic parts catalogue (ETKA)*
- Pressing off ⇒ [page 158](#)
- Pressing on ⇒ [page 158](#)

5 - Output shaft

- Adjusting ⇒ [page 144](#)

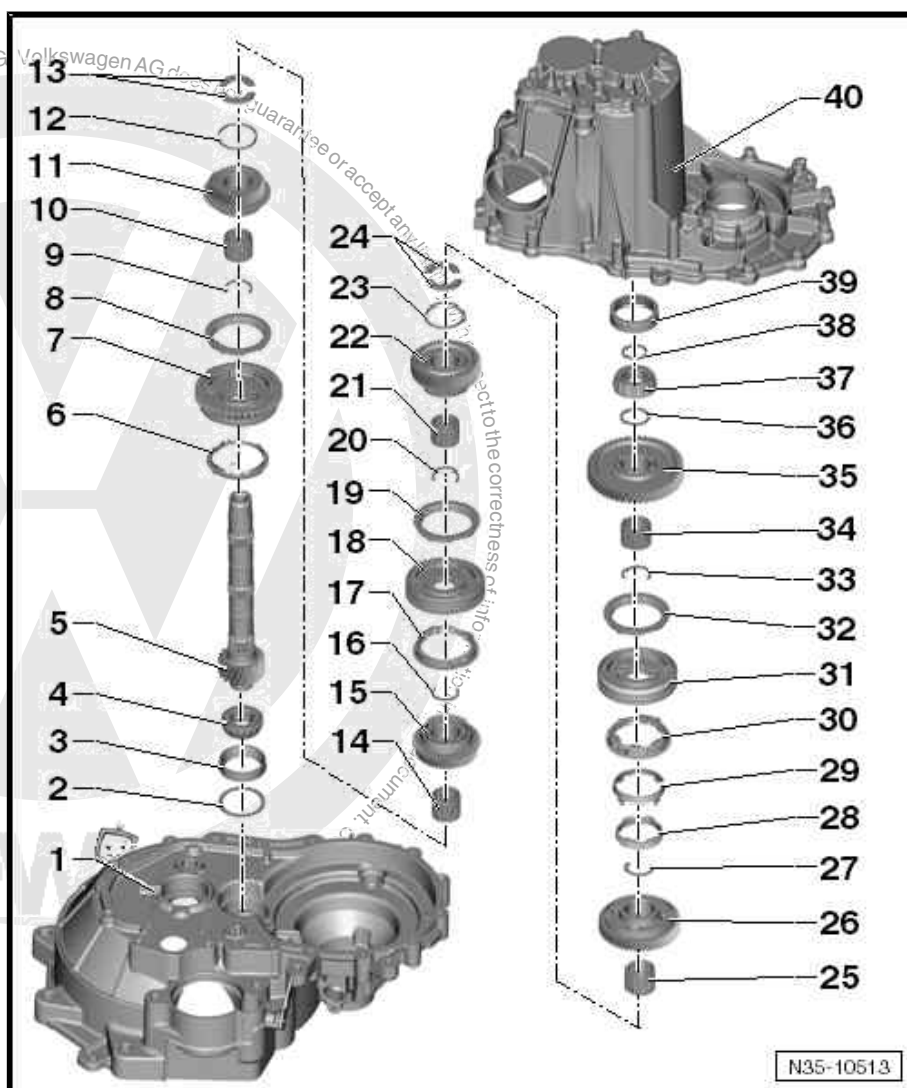



6 - Stop ring

- Prevents locking pieces from drifting out
- Remove ⇒ [page 163](#)
- Installing ⇒ [page 163](#)

7 - Locking collar with synchro-hub for 5th and reverse gears

- To be removed after removal of retaining ring ⇒ [Item 9 \(page 152\)](#)
- Dismantling and assembling ⇒ [page 163](#)
- Installation position and fitting onto shaft ⇒ [page 164](#)

8 - Synchro-ring for 5th gear

- Check for wear ⇒ [page 161](#)

9 - Retaining ring

- Renew after removal

10 - Needle bearing

- For 5th gear

11 - Synchronised gear, 5th gear

12 - Shim

- Holds thrust washers ⇒ [Item 13 \(page 152\)](#) in position on output shaft

13 - Thrust washers

- For 4th and 5th gears
- Qty. 2
- Insert lugs of thrust washer in holes of output shaft

14 - Needle bearing

- For 4th gear

15 - Synchronised gear for 4th gear

16 - Retaining ring

- Renew after removal

17 - Synchro-ring for 4th gear

- Check for wear ⇒ [page 161](#)

18 - Locking collar with synchro-hub for 3rd and 4th gears

- To be pulled off ⇒ [page 161](#) after removal of retaining ring ⇒ [Item 20 \(page 152\)](#)
- Dismantling ⇒ [page 162](#)
- Assembling locking collar and synchro-hub ⇒ [page 162](#) and ⇒ [page 162](#)
- Pressing on ⇒ [page 164](#)

19 - Synchro-ring for 3rd gear

- Check for wear ⇒ [page 161](#)

20 - Retaining ring

- Renew after removal

21 - Needle bearing

- For 3rd gear

22 - Synchronised gear for 3rd gear

23 - Shim

- Holds thrust washers ⇒ [Item 24 \(page 152\)](#) in position on output shaft

24 - Thrust washers

- For 2nd and 3rd gears
- Qty. 2
- Insert lugs of thrust washer in holes of output shaft



25 - Needle bearing

- For 2nd gear

26 - Synchromeshed gear, 2nd gear

27 - Retaining ring

- Renew after removal

28 - Synchro-ring (inner ring for 2nd gear)

- 1st/2nd gears synchronisation
- Fitting position ⇒ [page 164](#)

29 - Outer bearing race for 2nd gear

- 1st/2nd gears synchronisation
- Fitting position ⇒ [page 164](#)

30 - Synchro-ring for 2nd gear

- 1st/2nd gears synchronisation
- Fitting position ⇒ [page 164](#)
- Check for wear ⇒ [page 162](#)

31 - Locking collar with synchro-hub for 1st and 2nd gears

- To be removed after removal of retaining ring ⇒ [Item 33 \(page 153\)](#)
- Dismantling ⇒ [page 162](#)
- Assembling locking collar and synchro-hub ⇒ [page 162](#)
- Fitting position ⇒ [page 165](#)

32 - Synchro-ring for 1st gear

- Check for wear ⇒ [page 161](#)

33 - Retaining ring

- Renew after removal

34 - Needle bearing

- For 1st gear

35 - Synchromeshed gear, 1st gear

- Remove together with tapered roller bearing inner race ⇒ [Item 37 \(page 153\)](#) ⇒ [page 159](#)

36 - Thrust washer

- For 1st gear

37 - Tapered roller bearing inner race

- Pressing off ⇒ [page 159](#)
- Pressing on ⇒ [page 159](#)

38 - Retaining ring

- Renew after removal
- If tapered roller bearing and output shaft are renewed, redetermine ⇒ [page 160](#)

39 - Tapered roller bearing outer race

- Removing ⇒ [page 159](#)
- Pressing in ⇒ [page 159](#)

40 - Gearbox housing



2.2 Dismantling and assembling output shaft

Special tools and workshop equipment required

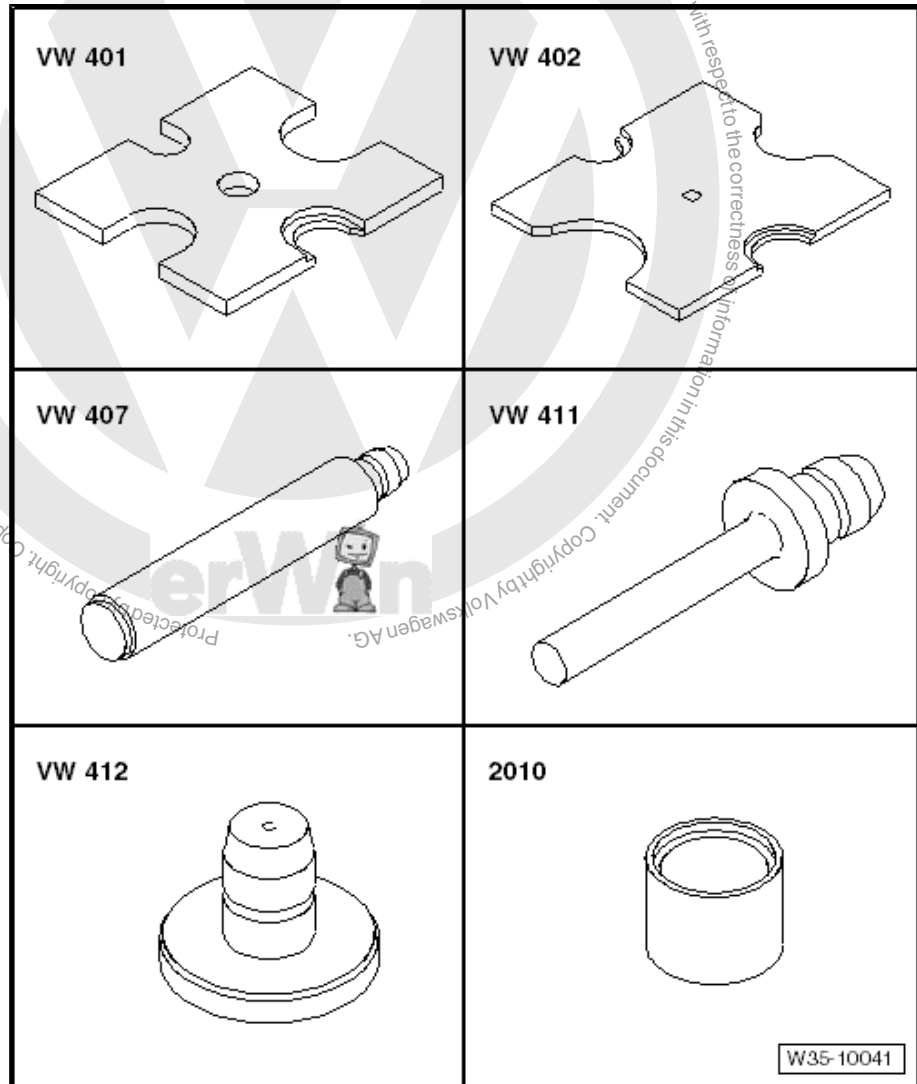

- ◆ Thrust plate - VW 401-
- ◆ Thrust plate - VW 402-
- ◆ Press tool - VW 407-
- ◆ Press tool - VW 411-
- ◆ Press tool - VW 412-
- ◆ Tube - 2010-

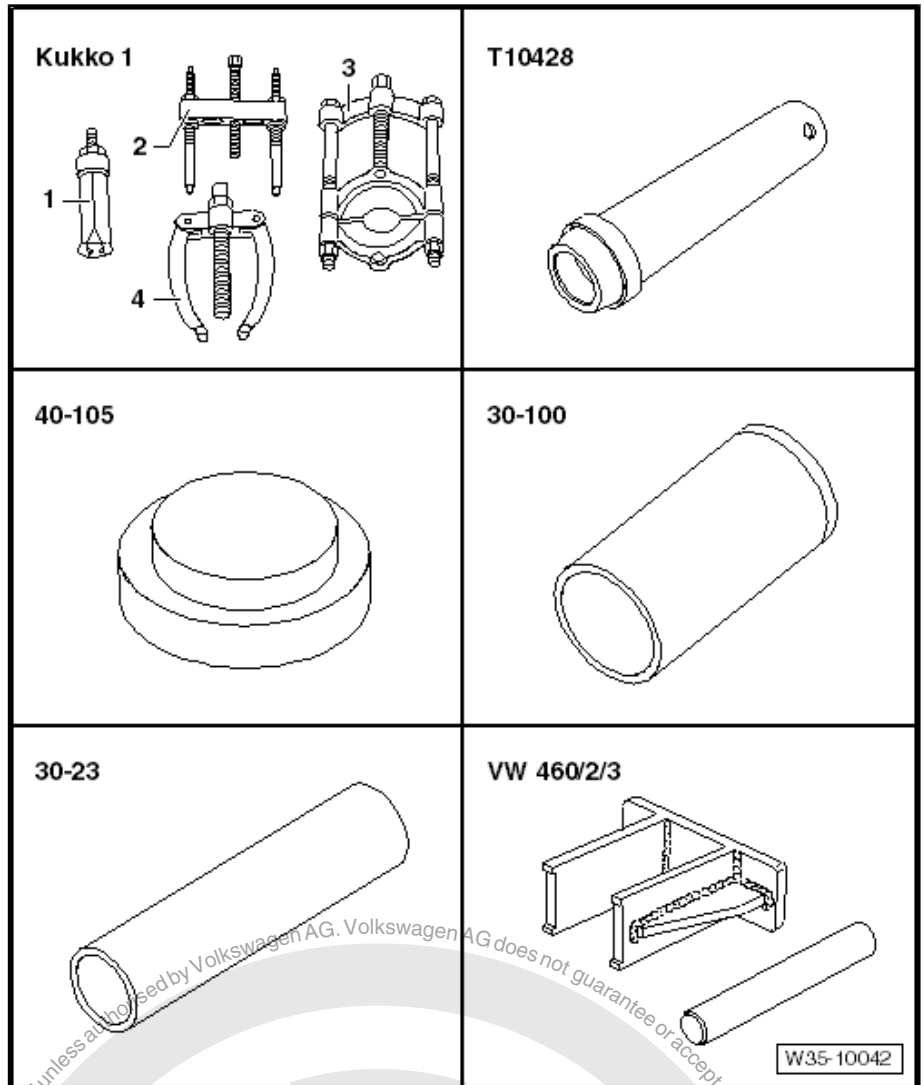

- ◆ Not applicable: -Kukko 1-
- ◆ Thrust plate - 40 - 105-
- ◆ Drift sleeve - 30 - 100-
- ◆ Extension - 30 - 23-
- ◆ Removing tool - VW 460/2-
- ◆ Thrust piece - T10428 ⇒ [page 158](#) or

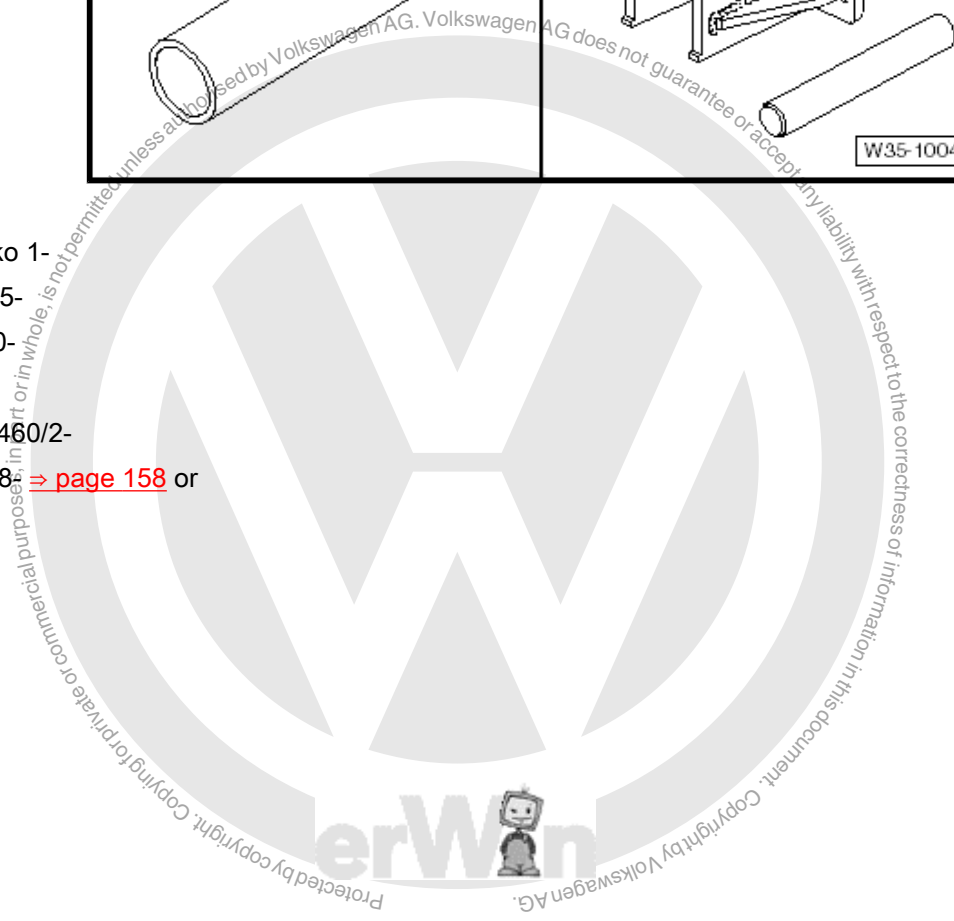



- ◆ Internal puller - VAS 251 613- , or internal puller , e.g. -Kukko 21/6-
- ◆ Counter support - VAS 251 623- or counter support , e.g. - Kukko 22/2-
- ◆ Splitter - VAS 251 411- , or e.g. splitter 22 ... 115 mm - Kukko 17/2-
- ◆ Splitter - VAS 251 409- or e.g. splitter - Kukko 17/1-
- ◆ Press tool - VW 473- ⇒ [page 158](#)





◆ Support rails - VW 457-



◆ Retainer - VW 801-

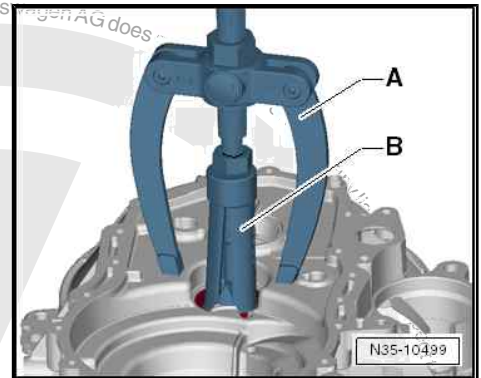
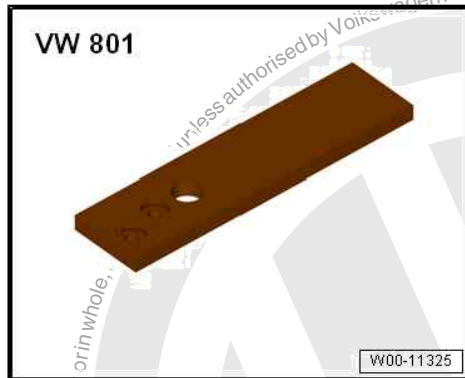

Pulling tapered roller bearing outer race out of clutch housing

A - Counter support - VAS 251 623- , or e.g. counter support , e.g. - Kukko 22/2-

B - Internal puller - VAS 251 613- , or e.g. internal puller 37...46 mm - Kukko 21/6-

Distinguishing between bearing seats for tapered roller bearing outer race

Note various diameters of bearing seat for tapered roller bearing outer race.

Dimension -a-	
51 mm	56 mm
Pressing tapered roller bearing outer race into clutch housing ⇒ page 158	Pressing tapered roller bearing outer race into clutch housing ⇒ page 158

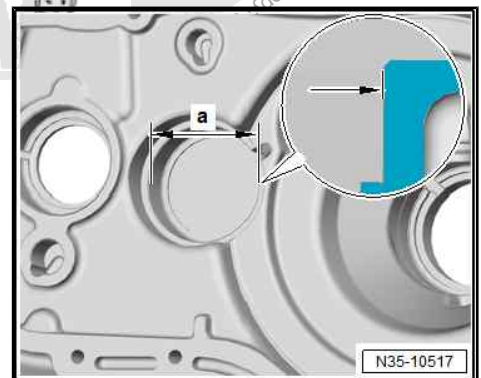



Bearing seat diameter = 51 mm; pressing tapered roller bearing outer race into clutch housing

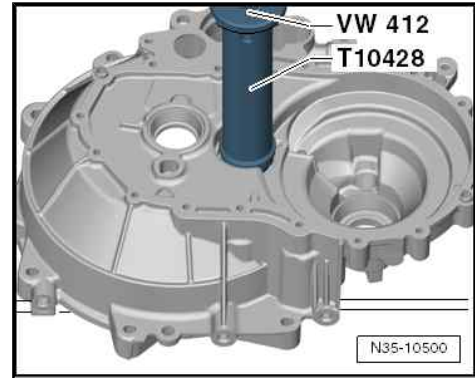

Bearing seat diameter = 56 mm; pressing tapered roller bearing outer race into clutch housing

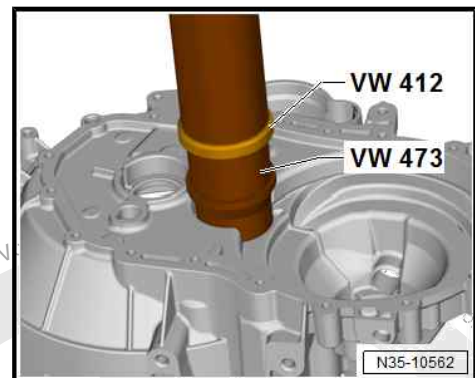

Pressing off tapered roller bearing inner race for bearing in clutch housing

A - Splitter - VAS 251 409- or splitter 12 ... 75 mm , e.g. -Kukko 17/1-

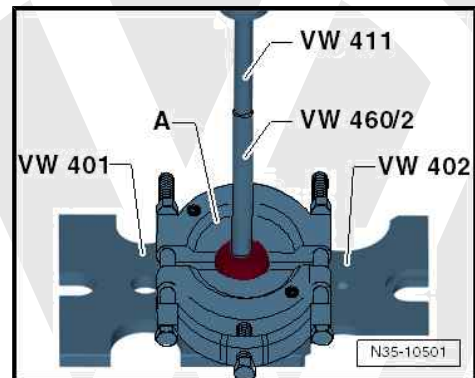

Pressing on tapered roller bearing inner race for bearing in clutch housing

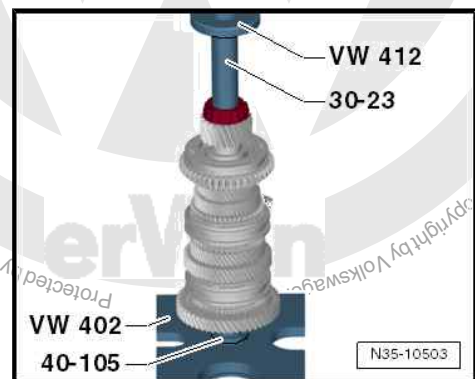



Pulling outer race for tapered roller bearing out of gearbox housing

A - Counter support - VAS 251 623- or counter support , e.g. - Kukko 22/2-

B - Internal puller - VAS 251 613- , or e.g. internal puller 37...46 mm - Kukko 21/6-

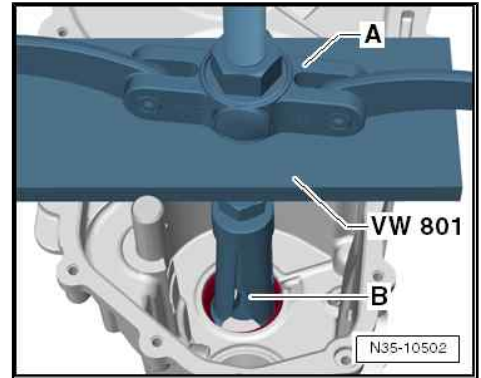

Pressing tapered roller bearing outer race into gearbox housing

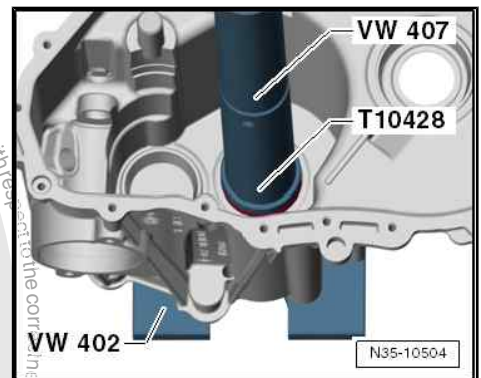

Press off tapered roller bearing inner race on side facing towards gearbox housing together with synchromeshed gear for 1st gear:

- First, remove retaining ring -A- for tapered roller bearing inner race.
- Fit support rails - VW 457- behind constant mesh teeth of synchromeshed gear for 1st gear (not dog teeth).

Below the tapered roller bearing inner race, the thrust washer for the synchromeshed gear for 1st gear is located.

- Note thrust washer => [Item 36 \(page 153\)](#) for synchromeshed gear for 1st gear.

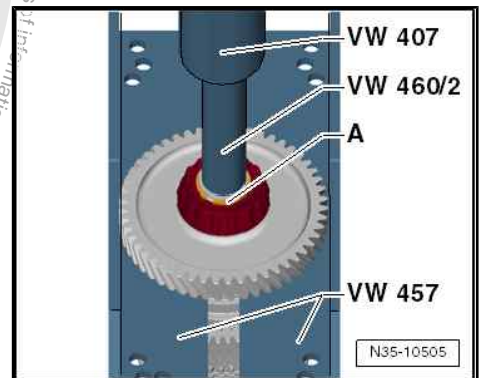

Press on tapered roller bearing inner race on side facing gearbox housing

- First, fit synchromeshed gear for 1st gear with thrust washer => [Item 36 \(page 153\)](#) for synchromeshed gear for 1st gear.
- Determine retaining ring for tapered roller bearing inner race (=> illustration on next page) and install.

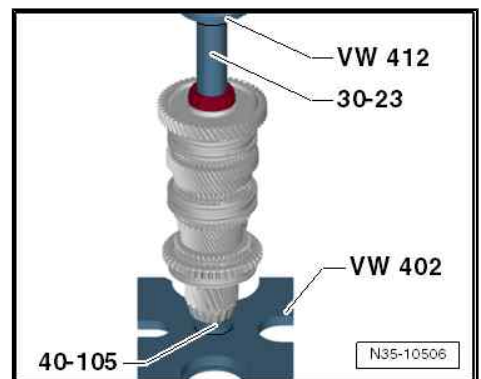



Determining thickness of retaining ring

- Determine the thickest circlip which will just fit and install it.
- Determine retaining ring from table. Part number → Electronic parts catalogue (ETKA)

Following retaining rings are available:

Thickness (mm)		
2.00	2.20	2.40
2.10	2.30	

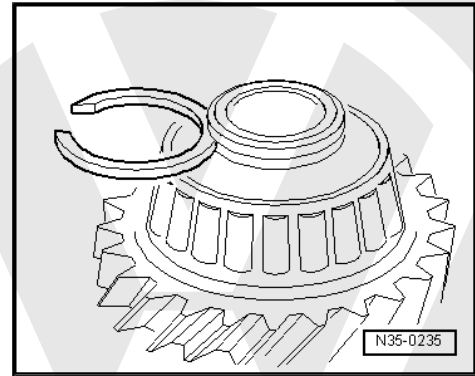

Dismantling output shaft

- Remove retaining ring -A- for tapered roller bearing inner race.
- Fit support rails - VW 457- behind constant mesh teeth of synchromeshed gear for 1st gear (not dog teeth).
- Press off synchromeshed gear for 1st gear together with tapered roller bearing inner race.

Below the tapered roller bearing inner race, the thrust washer for the synchromeshed gear for 1st gear is located.

- Remove thrust washer ⇒ [Item 36 \(page 153\)](#) for synchromeshed gear for 1st gear.
- Remove needle bearing for synchromeshed gear for 1st gear.
- Remove synchro-ring for 1st gear.
- Remove retaining ring for synchro-hub for 1st and 2nd gears.
- Remove locking collar and synchro-hub for 1st and 2nd gears.
- Remove synchromeshed gear for 2nd gear together with synchro-rings for 2nd gear.
- Remove retaining ring for needle bearing.
- Remove synchromeshed gear for 2nd gear.
- Remove needle bearing for synchromeshed gear for 2nd gear.
- Remove thrust washers for 2nd and 3rd gears with washer ⇒ [Item 23 \(page 152\)](#) .
- Remove synchromeshed gear for 3rd gear.
- Remove synchro-ring for 3rd gear with needle bearing.
- Remove retaining ring for synchro-hub and locking collar for 3rd and 4th gears.

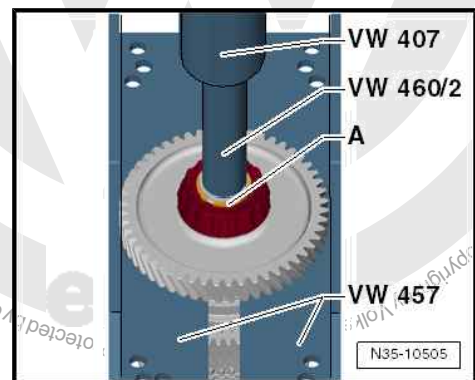



Pressing off synchro-hub and locking collar for 3rd and 4th gears with synchro-ring for 4th gear

A - Splitter - VAS 251 411- , or e.g. splitter 22 ... 115 mm - Kukko 17/2-

- Apply splitter -A- below synchro-ring for 4th gear.
- Renew synchro-ring for 4th gear when assembling.
- Remove synchro-ring for 4th gear.
- Remove synchromeshed gear for 4th gear.
- Remove retaining ring located above needle bearing for synchromeshed gear for 4th gear.
- Remove needle bearing for synchromeshed gear for 4th gear.
- Remove thrust washers for 4th and 5th gears, with washer => [Item 12 \(page 152\)](#) .
- Remove synchromeshed gear for 5th gear.
- Remove needle bearing for synchromeshed gear for 5th gear.
- Remove synchro-ring for 5th gear.
- Remove retaining ring for locking collar and synchro-hub for 5th and reverse gears.
- Remove locking collar and synchro-hub for 5th and reverse gears.

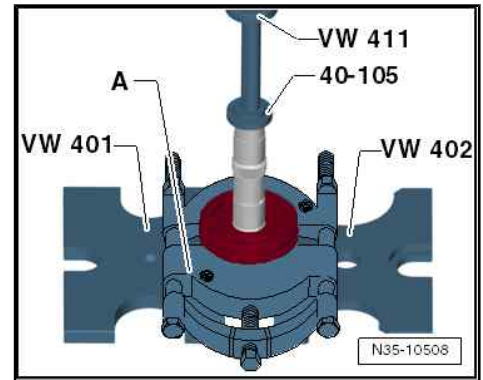

Assembling output shaft

Checking synchro-rings for 1st and 3rd to 5th gears for wear

- Press synchro-ring onto cone of synchromeshed gear, and measure gap -a- at 3 points offset by 120° using a feeler gauge.
- Make a note of average value.

Gap -a-	Installation dimension	Wear limit
1st and 3rd to 5th gears	1.0...1.7 mm	0.9 mm

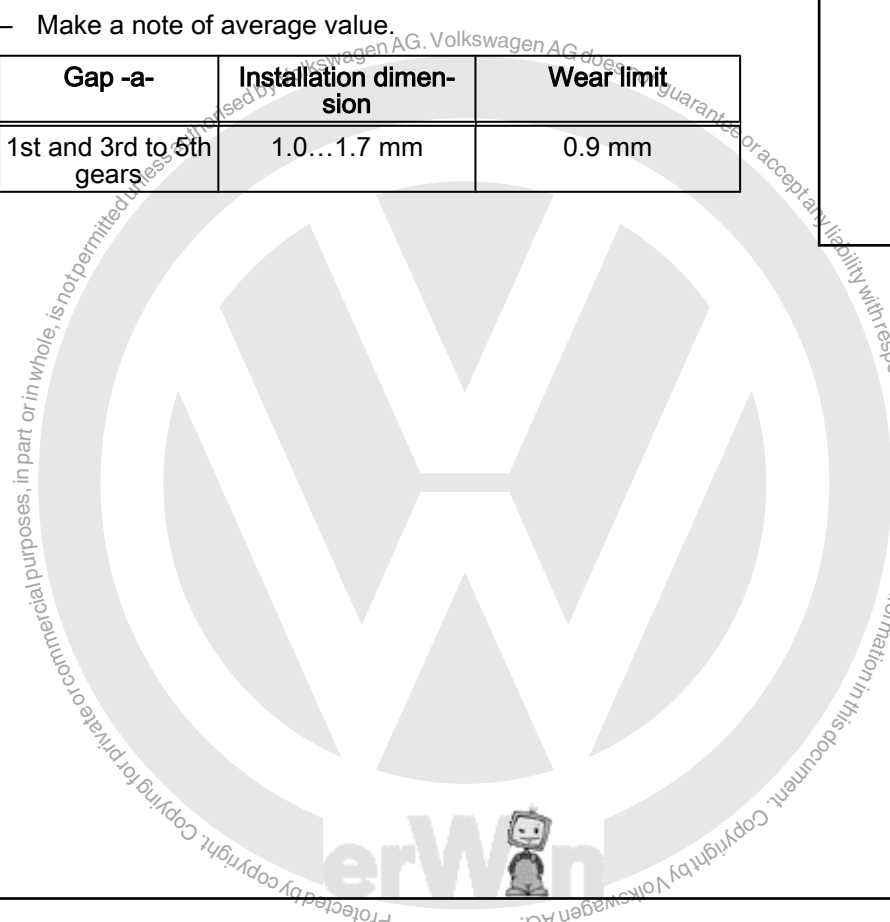
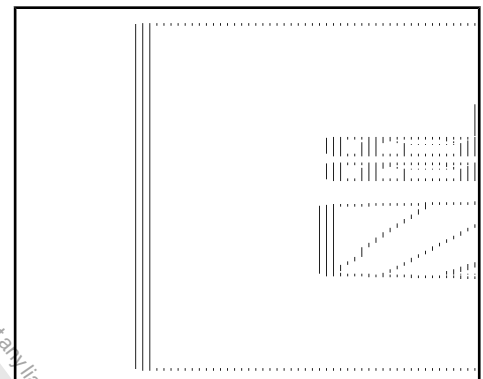



Checking 2nd gear synchro-ring, outer ring and inner ring together for wear

- Check inner contact surface of synchro-ring -arrow- for scoring and radial contact scoring; if necessary, renew inner race, outer race and synchro-ring
- Place inner ring, outer ring and synchro-ring on cone of inner ring.
- Press down and simultaneously rotate synchro-ring to achieve proper seating.
- Measure gap size -a- at 3 points offset by 120° using feeler gauge.
- Make a note of average value.

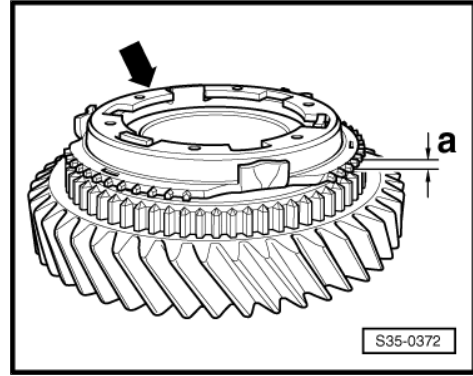

Gap -a-	Installation dimension	Wear limit
2nd gear	1.0 ... 1.9 mm	0.9 mm



Note

Always renew inner ring, outer ring and synchro-ring together.

Dismantling and assembling locking collar and synchro-hub for 1st, 2nd, 3rd and 4th gears

- 1 - Spring
 - 2 - Locking piece
 - 3 - Sliding sleeve
 - 4 - Synchro-hub
- Slide locking collar over synchro-hub.

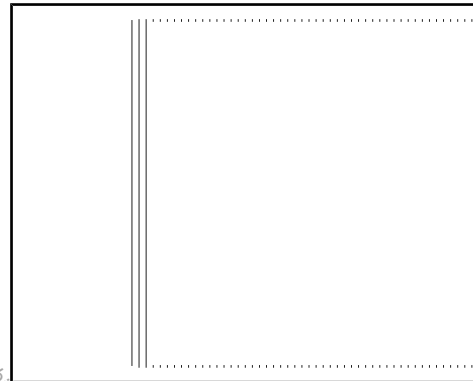

Assembling locking collar and synchro-hub for 1st, 2nd, 3rd and 4th gears

Locking collar has been pushed over synchro-hub.

- Insert locking pieces and install springs offset 120°. Angled end of spring must locate in hollow locking piece.

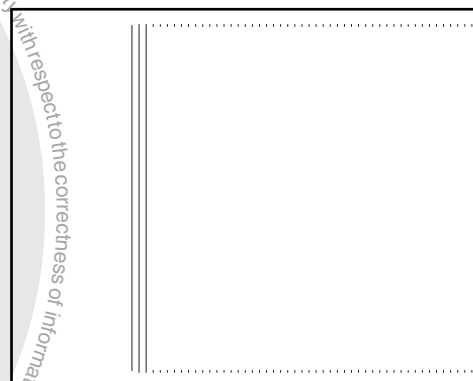

Protected by copyright. Copying for private or commercial purposes, in part or in whole, is not permitted unless authorized by Volkswagen AG. Volkswagen AG does not guarantee or accept any liability with respect to the correctness of information in this document. Copyright by Volkswagen AG.



Dismantling and assembling locking collar and synchro-hub for 5th and reverse gears

- 1 - Spring
 - 2 - Locking piece
 - 3 - Synchro-hub
 - 4 - Sliding sleeve
 - 5 - Stop ring: removing ⇒ [page 163](#) ; installing ⇒ [page 163](#)
- Slide locking collar over synchro-hub.
 - Teeth -arrow A- and flat shoulder -arrow B- are facing in same direction
 - Deeper notches -arrow C- for locking pieces in synchro-hub and notches -arrow D- in locking collar must align.
 - Insert locking pieces -2-, and install springs -1- offset by 120 degrees.
 - Angled end of spring must locate in hollow locking piece.
 - Install stop ring -5- ⇒ [page 163](#) .

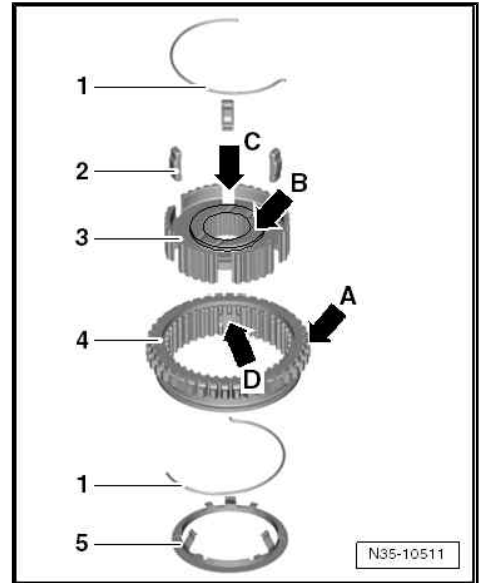

Removing stop ring for locking pieces of locking collar with synchro-hub for 5th and reverse gears

- Press tube - 2010- into stop ring of synchro-hub. In the process, lever stop ring on alternating sides out of synchro-hub.
- Stop ring must be completely on tube - 2010- ⇒ [page 163](#) .
- Remove stop ring together with tube - 2010- .

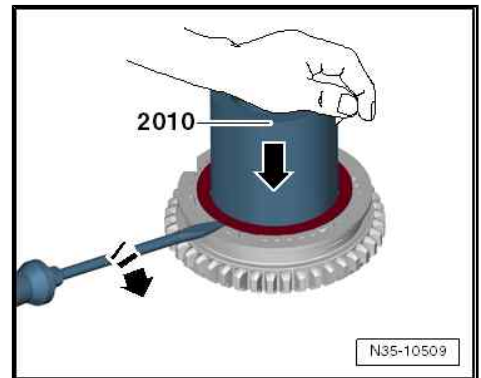

Removing stop ring for locking pieces on locking collar with synchro-hub for 5th and reverse gears

Insert stop ring together with tube - 2010- into synchro-hub with locking collar for 5th gear.

The 3 lugs -arrow 1- engage in the 3 recesses -arrow 2- for the synchro-hub locking pieces. (The illustration shows only 2 lugs and 2 recesses.)

Remove tube - 2010- , making sure that the lugs -arrow- engage in the synchro-hub.

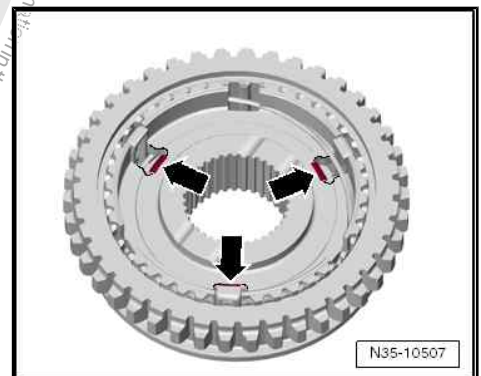
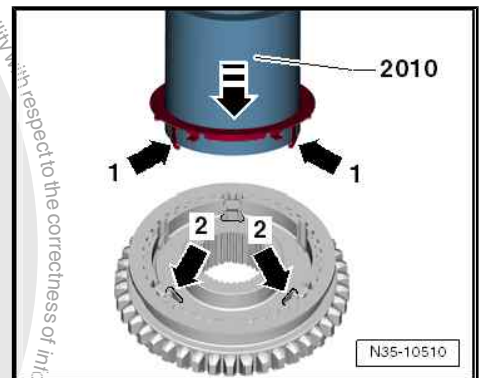



Installation position of locking collar and synchro-hub for 5th and reverse gears

- ◆ The support -arrow 1- for the selector fork faces towards the splines -arrow 2-.
- Stop ring for locking pieces for 5th and reverse gears is installed ⇒ [page 163](#) .
- Fit locking collar and synchro-hub for 5th and reverse gears.
- Install retaining ring.
- Insert synchro-ring for 5th gear.
- Install 5th gear synchromeshed gear with needle bearing.
- Install thrust washers for 4th and 5th gears ⇒ [Item 13 \(page 152\)](#) and ⇒ [Item 12 \(page 152\)](#) .
- Fit needle bearing for 4th gear synchromeshed gear.
- Install retaining ring.
- Fit synchromeshed gear for 4th gear.
- Fit synchro-ring for 4th gear.

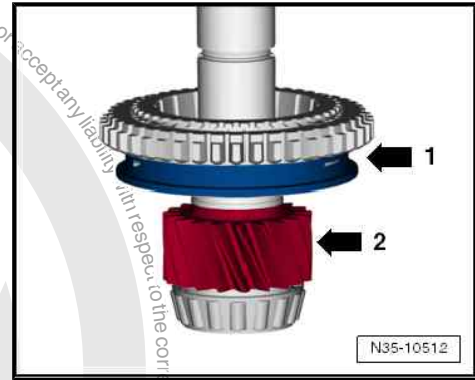

Pressing on synchro-hub with locking collar for 3rd and 4th gears

- Install retaining ring.
- Insert synchro-ring for 3rd gear.
- Set 3rd gear synchromeshed gear with needle bearing in place.
- Install thrust washers for 2nd and 3rd gears ⇒ [Item 24 \(page 152\)](#) and ⇒ [Item 23 \(page 152\)](#) .
- Set 2nd gear synchromeshed gear with needle bearing in place.
- Install retaining ring.

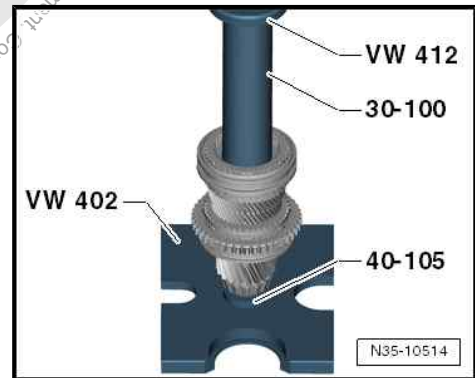

Installation position of outer ring, inner ring and synchro-ring for 2nd gear

- Place inner ring -A- on synchromeshed gear.
- ◆ Lugs -1- point away from synchromeshed gear.
- Fit outer ring -B-.
- ◆ Lugs -2- engage in notches -3- of synchromeshed gear.
- Fit synchro-ring -C-.
- ◆ Larger notches -4- engage in lugs -1- of inner ring -A-.
- Fit synchro-ring for 2nd gear.

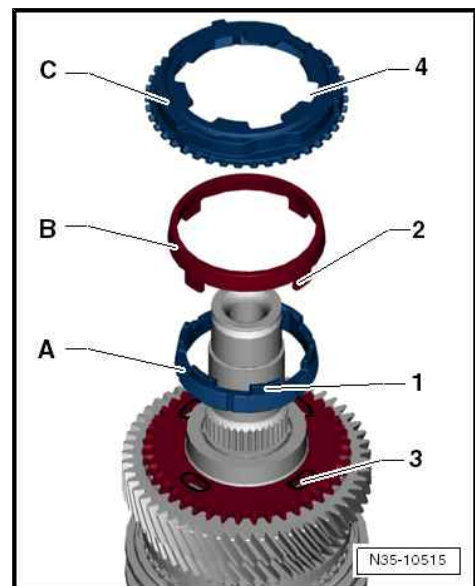



Installation position of locking collar with synchro-hub for 1st and 2nd gears

- ◆ The chamfer -arrow 1- points away from synchromeshed gear for 2nd gear -arrow 2-
- Fit locking collar and synchro-hub for 1st and 2nd gears.
- Install retaining ring.
- Insert synchro-ring for 1st gear.
- Install synchromeshed gear for 1st gear with needle bearing.
- Fit thrust washer for 1st gear ⇒ [Item 36 \(page 153\)](#) .

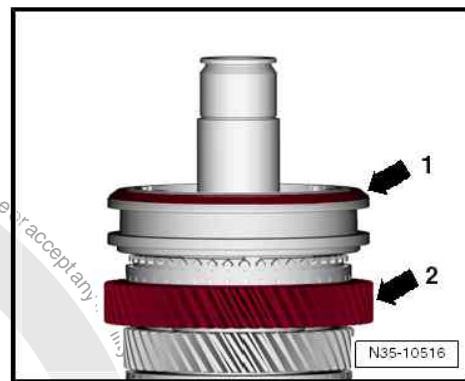

Note

Pressing on tapered roller bearing inner race for bearing in gearbox housing ⇒ [page 159](#) .

- Install retaining ring ⇒ [page 160](#) .

2.3 Adjusting output shaft

Special tools and workshop equipment required

<p>VW 313</p>	<p>T10484</p>
<p>VW 385/17</p>	<p>VW 387</p>
<p>VW 412</p>	<p>T10428</p>



- ◆ Support clamp - VW 313-
- ◆ Gearbox support - T10484-
- ◆ End dimension plate - VW 385/17-
- ◆ Universal dial gauge holder - VW 387-
- ◆ Press tool - VW 412-
- ◆ Thrust piece - T10428- ⇒ [page 158](#) or
- ◆ Press tool - VW 473- ⇒ [page 158](#)



- ◆ Internal puller - VAS 251 613- , or internal puller , e.g. -Kukko 21/6-



- ◆ Counter support - VAS 251 623- or counter support , e.g. - Kukko 22/2-





◆ Adapter - T10480-

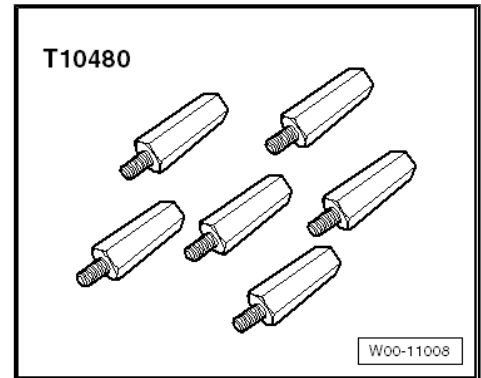

◆ Torque wrench - V.A.G 1331-

◆ Dial gauge - VAS 6080A-

◆ 30 mm dial gauge extension

(Determining shim for output shaft)

It is necessary to readjust the output shaft when the following components are renewed:

- ◆ Gearbox housing
- ◆ Clutch housing
- ◆ Output shaft
- ◆ Tapered roller bearing for output shaft

Adjustment overview ⇒ [page 185](#)

Requirement:

- Sealing surfaces of clutch and gearbox housings must be free of sealant .
- Both inner races for tapered roller bearings are pressed onto output shaft ⇒ [page 158](#) and ⇒ [page 159](#) .
- Tapered roller bearing outer race is pressed into gearbox housing ⇒ [page 159](#) .
- Remove reverse shaft ⇒ [page 170](#) .
- Press tapered roller bearing outer race with 1.4 mm thick shim into clutch housing ⇒ [page 158](#) or ⇒ [page 158](#) .
- Fit output shaft into gearbox housing.
- Fit clutch housing, and diagonally tighten bolts to specified torque ⇒ [Item 3 \(page 117\)](#) .



- Set up measuring tools.
- Set dial gauge (3 mm measuring range) to "0" with 1 mm preload.
- Loosen clutch housing/gearbox housing securing bolts diagonally until the bolts release the clutch housing or output shaft.
- Do not move the clutch housing by hand
- Read and note value on dial gauge (example: 0.6 mm).

Determining thickness of shim

The specified bearing preload will be attained by subtracting the measured value (0.60 mm) from the inserted shim (1.40 mm) and adding a constant value for preload (0.15 mm).

Example:

Installed shim	1.40 mm
- Measured value	0.60 mm
+ Preload (constant)	0.15 mm
Shim thickness	0.95 mm

- Determine thickness of shim from table.
- For part number of shim, refer to ⇒ Electronic parts catalogue (ETKA) .

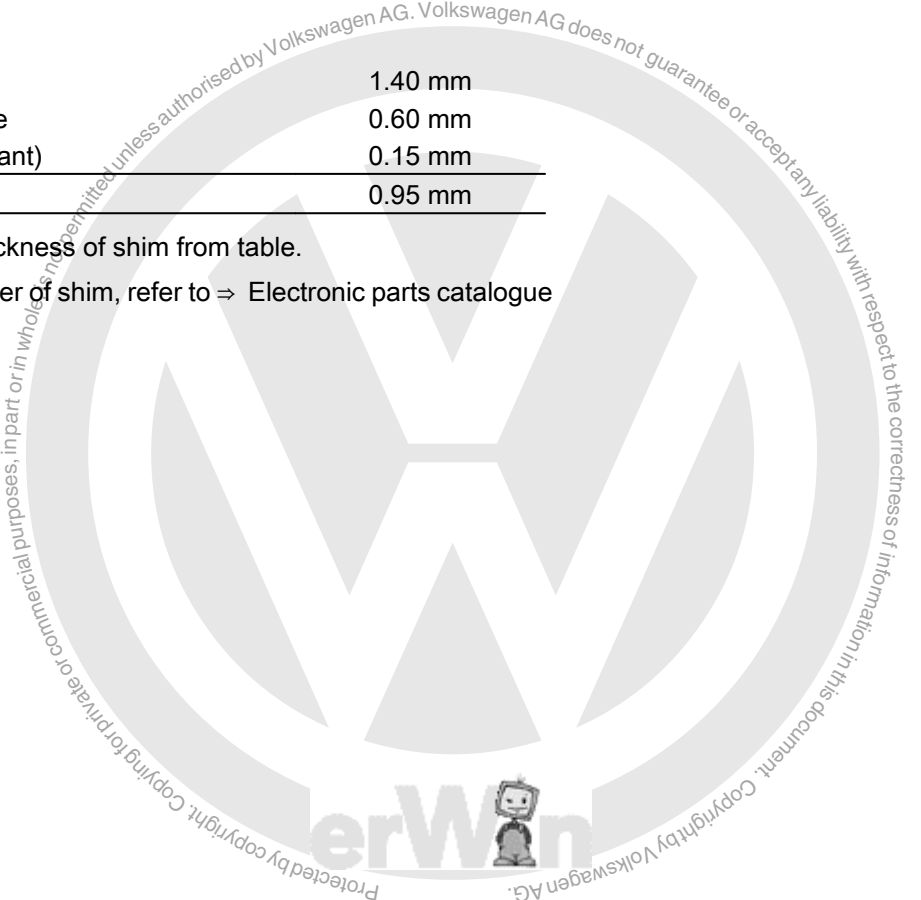
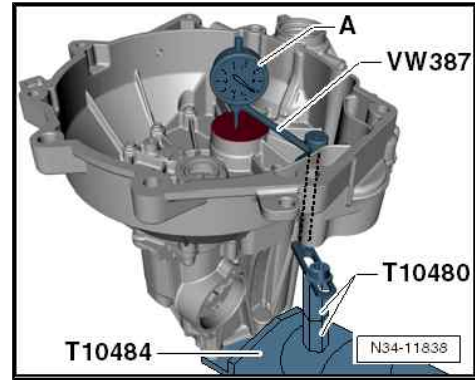



- Remove clutch housing, and pull out tapered roller bearing outer race.

A - Counter support - VAS 251 623- or counter support , e.g. - Kukko 22/2-

B - Internal puller - VAS 251 613- , or e.g. internal puller 37...46 mm - Kukko 21/6-

- Remove inserted shim (1.40 mm thick) from clutch housing.

The various thicknesses make it possible to achieve the exact shim thickness required.

If the size of shim required is larger than those listed in the table, insert two shims totalling the correct figure.

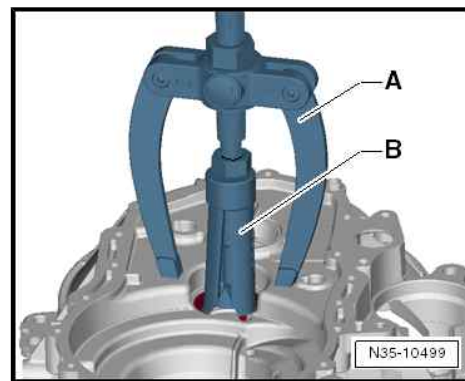

Table of shims

Thickness (mm)		
0.650	0.800	0.950
0.675	0.825	0.975
0.700	0.850	1.000
0.725	0.875	1.025
0.750	0.900	1.050
0.775	0.925	1.075

Thickness (mm)		
1.100	1.250	1.400
1.125	1.275	
1.150	1.300	
1.175	1.325	
1.200	1.350	
1.225	1.375	

- Press tapered roller bearing outer race with 1.4 mm thick shim into clutch housing ⇒ [page 158](#) or ⇒ [page 158](#) .

Carrying out check measurement

- Determined shim installed.
- Set up measuring tools.
- Set dial gauge (3 mm measuring range) to “0” with 1 mm pre-load.
- Loosen clutch housing/gearbox housing securing bolts diagonally until the bolts release the clutch housing or output shaft.
- If correct shim has been selected, dial gauge will indicate a value between 0.15 mm to 0.25 mm.

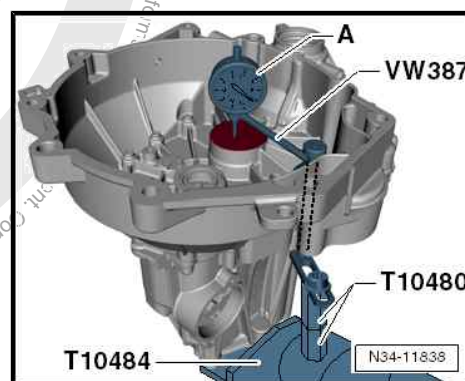



3 Reverse shaft

⇒ "3.1 Removing and installing reverse shaft", page 170

3.1 Removing and installing reverse shaft

- Remove clutch housing ⇒ [page 124](#) .
- Remove reverse gear wheel with roller bearing and thrust washers ⇒ [page 124](#) .
- Using pliers, pull reverse shaft out of gearbox housing.

The reverse shaft will be damaged when removed.

- Using plastic hammer, carefully drive in new reverse shaft.

Dimension - a - = 41.5 mm

- Install reverse gear wheel, roller bearing and thrust washers ⇒ [page 124](#) .
- Install clutch housing ⇒ [page 124](#) .

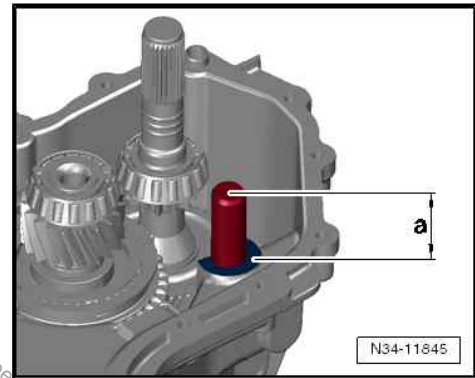



39 – Final drive - differential

1 Oil seals

⇒ [“1.1 Overview of fitting locations - seals”, page 171](#)

⇒ [“1.2 Renewing left seal”, page 172](#)

⇒ [“1.3 Renewing right oil seal”, page 173](#)

1.1 Overview of fitting locations - seals

The illustration of gearbox is different from the original gearbox.

1 - Seal

- For input shaft
- Renew after removal
⇒ [page 149](#)

2 - Seal

- For right drive shaft
- Renew after removal
⇒ [page 173](#)

3 - Seal

- For left drive shaft
- Renew after removal
⇒ [page 172](#)

4 - Seal

- For selector shaft
- Renew after removal
⇒ [page 83](#)

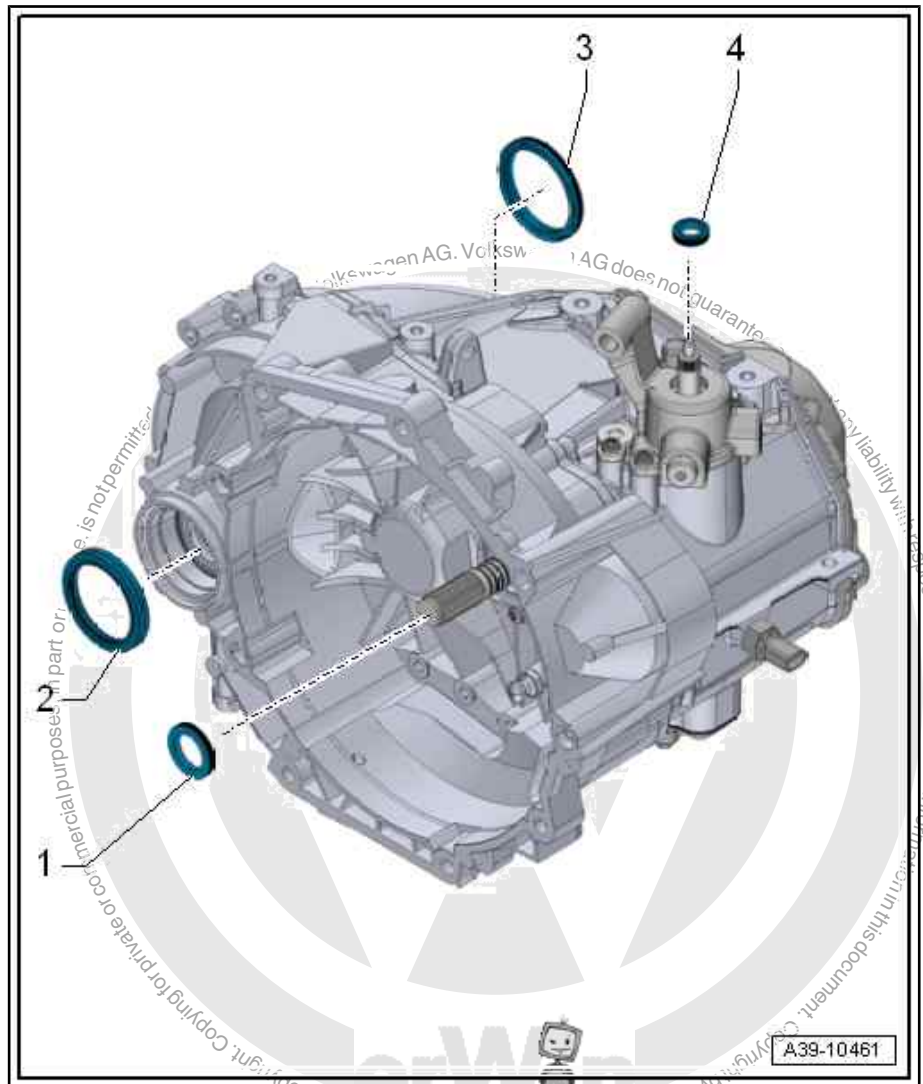



1.2 Renewing left seal

⇒ ["1.2.1 Renewing seal for left drive shaft", page 172](#)

1.2.1 Renewing seal for left drive shaft

Special tools and workshop equipment required

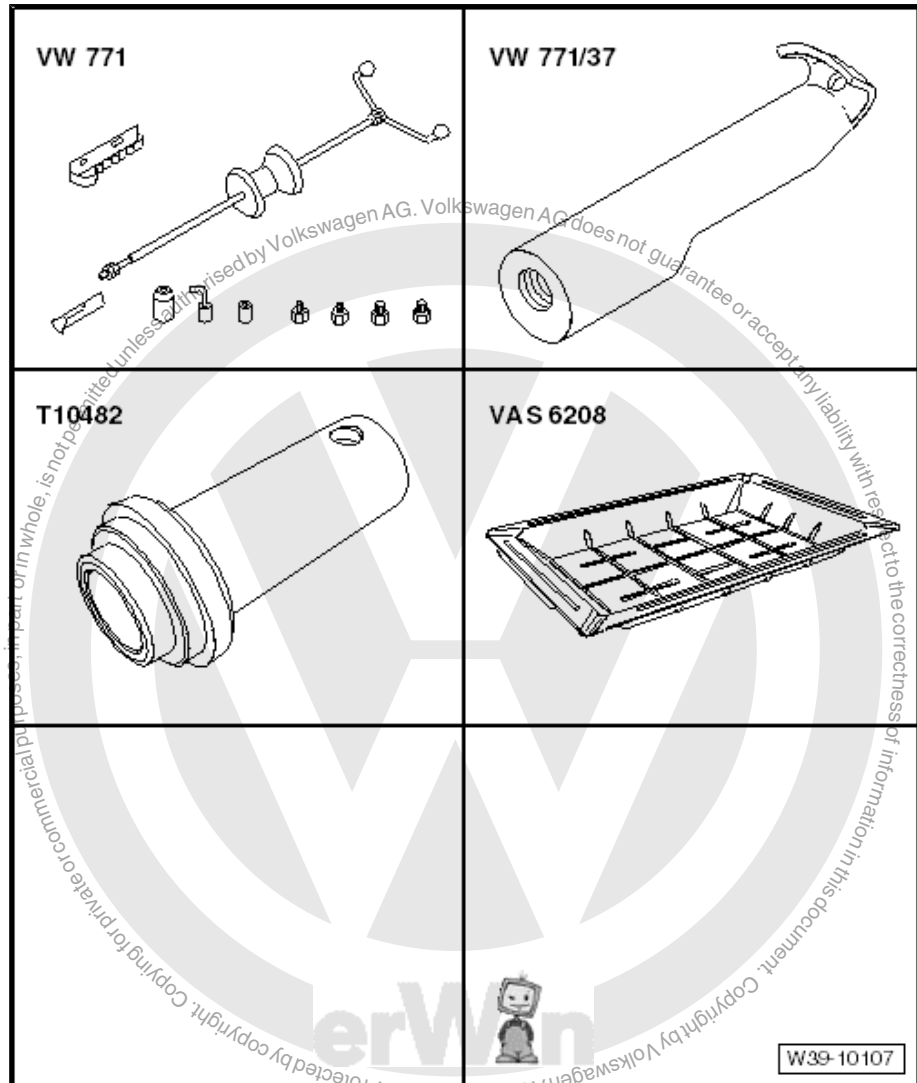

- ◆ Multi-purpose tool - VW 771-
- ◆ Extractor hook - VW 771/37-
- ◆ Press tool - T10482-
- ◆ Drip tray - V.A.G 1306-
- ◆ or drip tray for workshop hoist - VAS 6208-
- ◆ Sealing grease
- ◆ Allocate grease using ⇒ Electronic parts catalogue (ETKA) .

Removing

- Place drip tray under gearbox.
- Cover pendulum support.



- Drain gearbox oil -arrow- => [page 134](#) .
- Remove drive shaft => Running gear, axles, steering; Rep. gr. 40 ; Drive shaft; Removing and installing drive shaft .

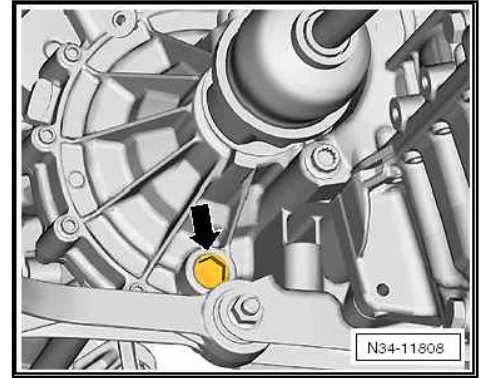

- Pull out drive shaft seal using -VW 771- and -VW 771/37- .

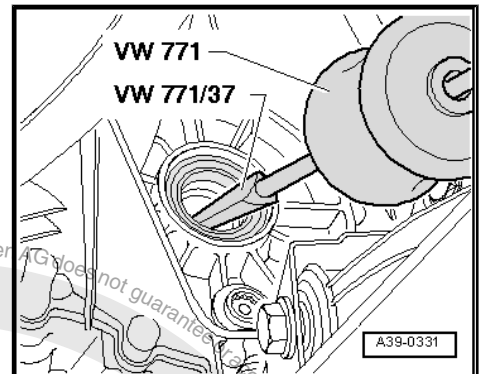

Installing

- Drive in new seal to stop, being careful not to cant seal.

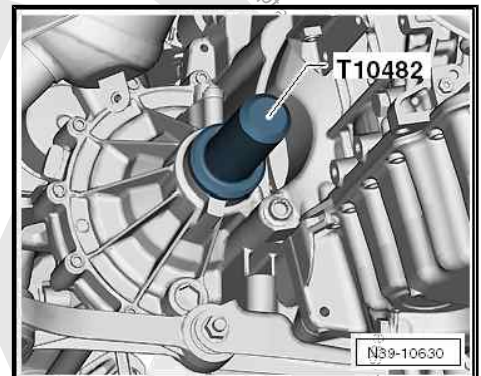

- Half-fill space between sealing lip and dust lip with sealing grease .
- Install drive shaft => Running gear, axles, steering; Rep. gr. 40 ; Drive shaft; Removing and installing drive shafts .
- Fill with gear oil => [page 134](#) .

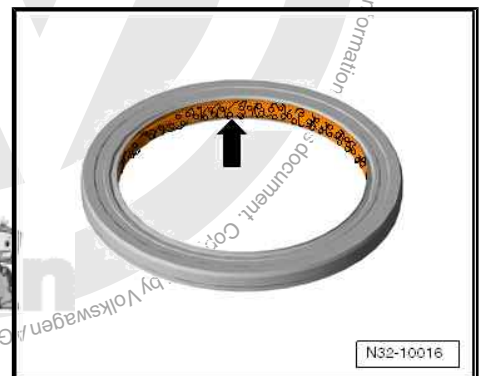

1.3 Renewing right oil seal

=> ["1.3.1 Renewing seal for right drive shaft", page 173](#)

1.3.1 Renewing seal for right drive shaft

For the removal of the right seal, the same procedure applies as for the removal of the left seal => [page 172](#) .



2 Differential

⇒ [“2.1 Assembly overview - differential”, page 174](#)

⇒ [“2.2 Dismantling and assembling differential”, page 175](#)

⇒ [“2.3 Adjusting differential”, page 182](#)

2.1 Assembly overview - differential

1 - Left drive shaft seal

- Renew after removal
⇒ [page 172](#)

2 - Gearbox housing

- Repairing ⇒ [page 131](#)
- Allocation ⇒ Electronic parts catalogue (ETKA)

3 - Baffle plate

- Renew after removal
- Shoulder points away from housing

4 - Tapered roller bearing outer race

- Removing ⇒ [page 180](#)
- Pressing in
⇒ [page 181](#) .

5 - Tapered roller bearing inner race

- Pulling off ⇒ [page 179](#)
- Pressing on
⇒ [page 180](#)

6 - Differential cage

- With differential bevel gears, one-piece thrust washer, differential pinion pin and final drive gear
- Removing differential bevel gears, one-piece thrust washer and differential pinion pin
⇒ [page 181](#)
- Installing differential bevel gears, one-piece thrust washer and differential pinion pin ⇒ [page 181](#)

7 - Tapered roller bearing inner race

- Pulling off ⇒ [page 179](#)
- Pressing on ⇒ [page 180](#)

8 - Tapered roller bearing outer race

- Pressing out ⇒ [page 179](#) .
- Pressing in ⇒ [page 179](#) .

9 - Shim

- For differential
- Determining thickness ⇒ [page 182](#)

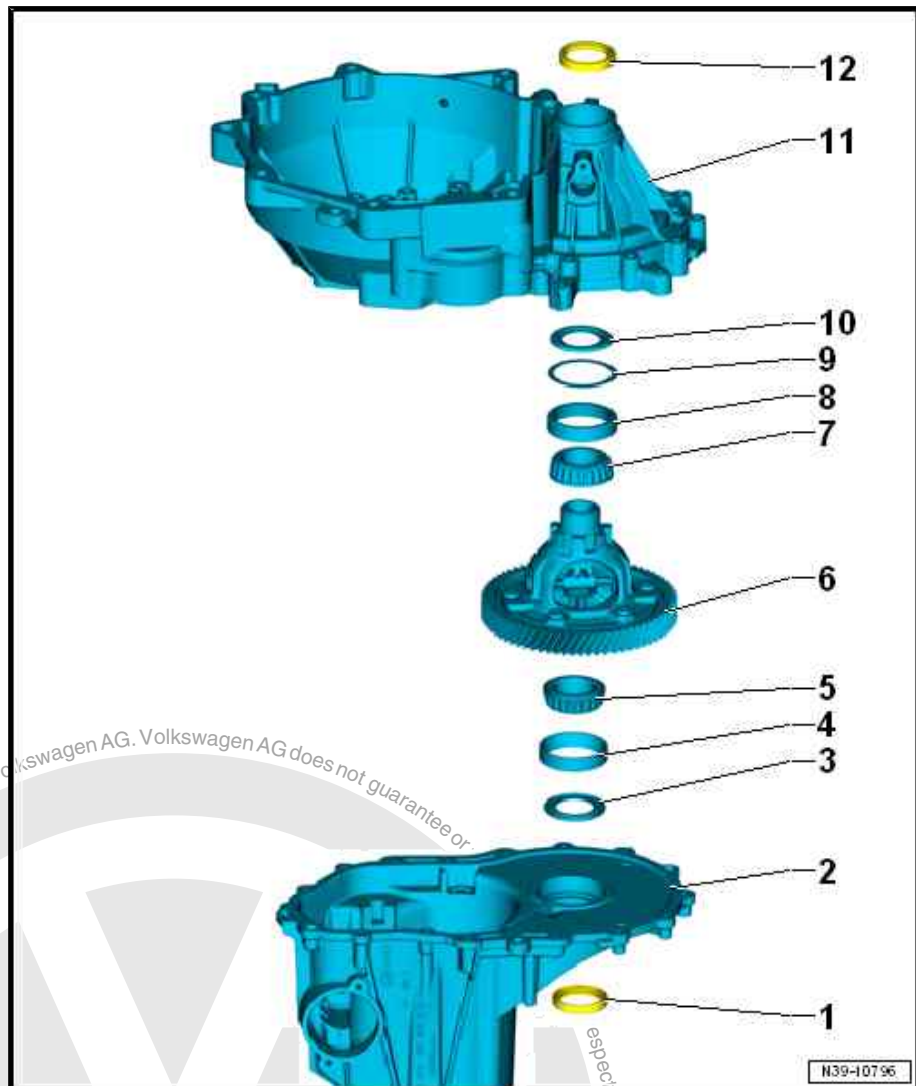



10 - Baffle plate

- Renew after removal
- Shoulder points away from housing

11 - Clutch housing

- Repairing ⇒ [page 131](#)

12 - Seal for right drive shaft

- Renew after removal ⇒ [page 173](#)

2.2 Dismantling and assembling differential

Special tools and workshop equipment required

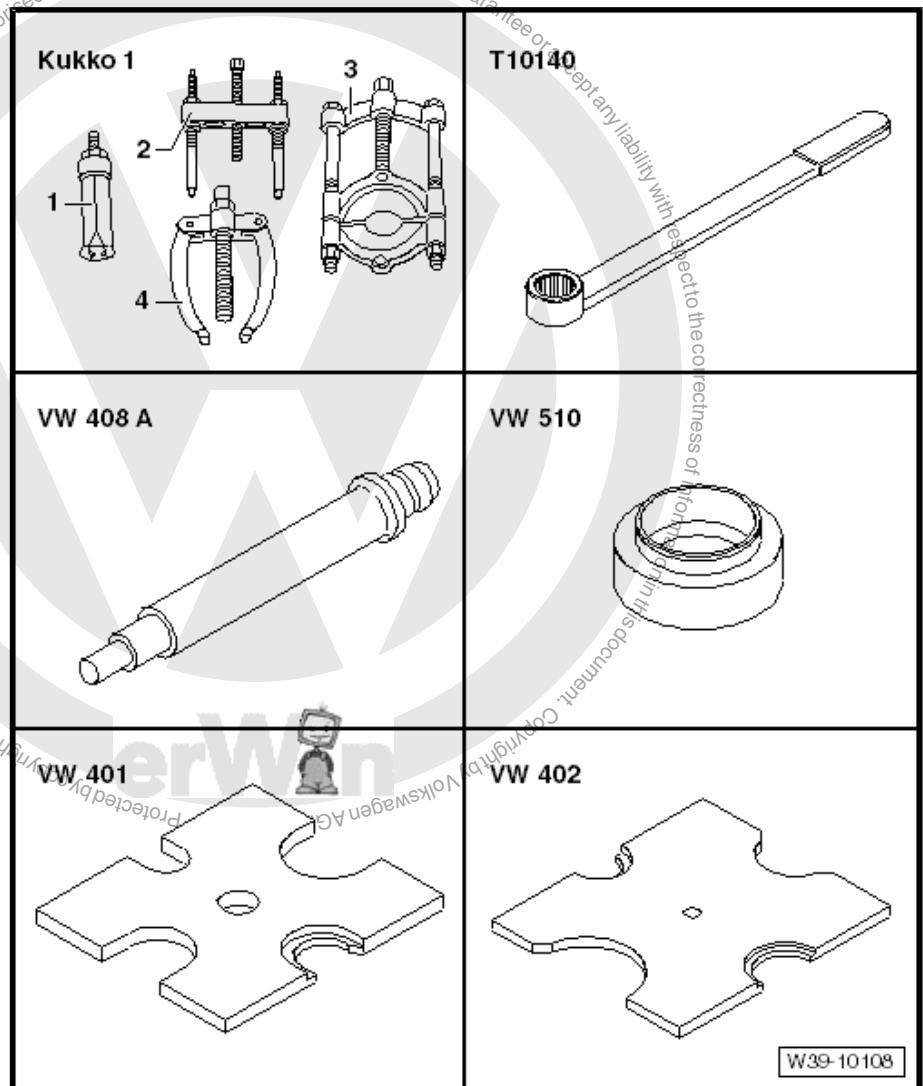

- ◆ Not applicable -Kukko 1-
- ◆ Gearbox support - T10484-
- ◆ Support clamp - VW 313-
- ◆ Counterhold tool - T10140- or 8 x 280 steel bar
- ◆ Press tool - VW 408 A-
- ◆ Thrust plate - VW 510-



- ◆ Thrust plate - VW 401-
- ◆ Thrust plate - VW 402-
- ◆ Internal puller - VAS 251 615- , or internal puller 46 ... 58 mm ,
e.g. -Kukko 21/7-

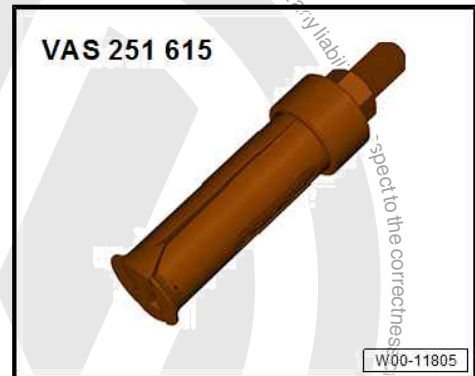

- ◆ Counter support - VAS 251 623- or counter support , e.g. -
Kukko 22/2-



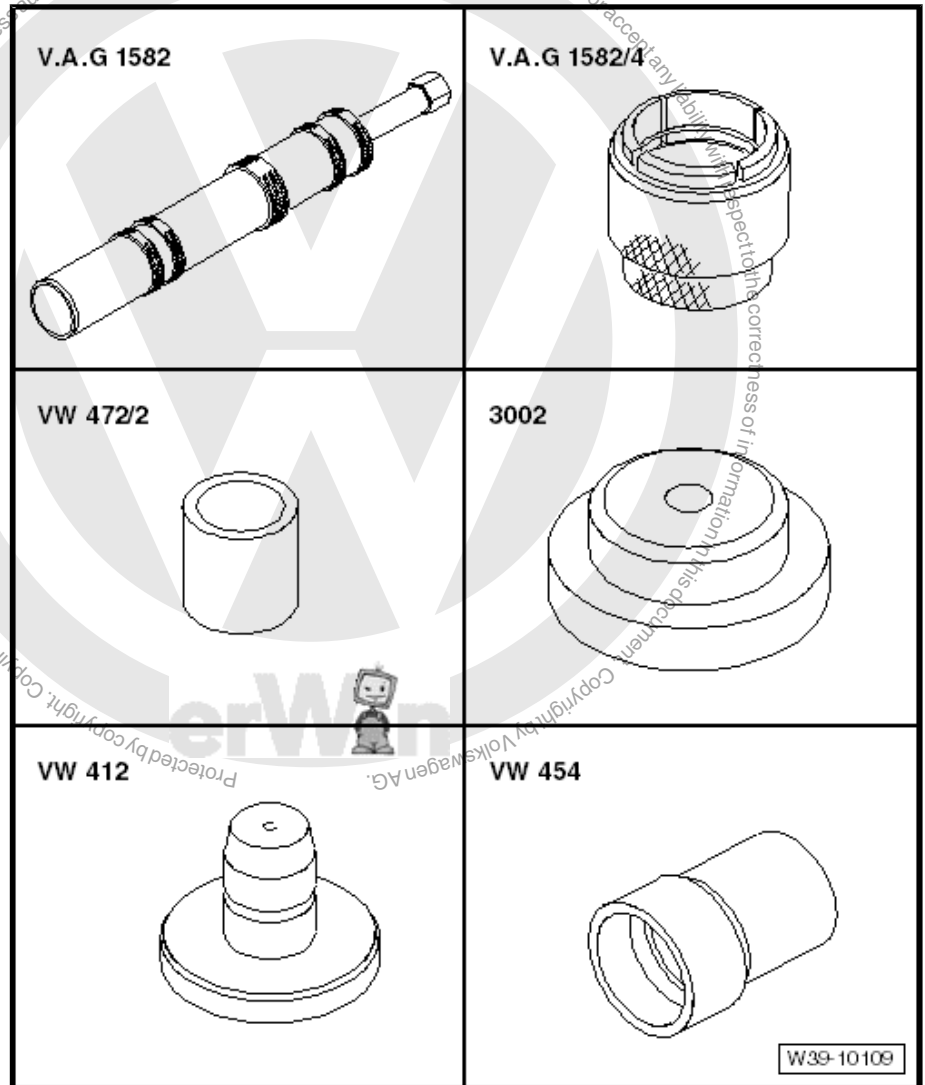

- ◆ Tapered roller bearing puller - V.A.G 1582-
- ◆ Grip tool - V.A.G 1582/4-
- ◆ Spacer sleeve - VW 472/2-
- ◆ Press tool - 3002-
- ◆ Press tool - VW 412-
- ◆ Press tool - VW 454-

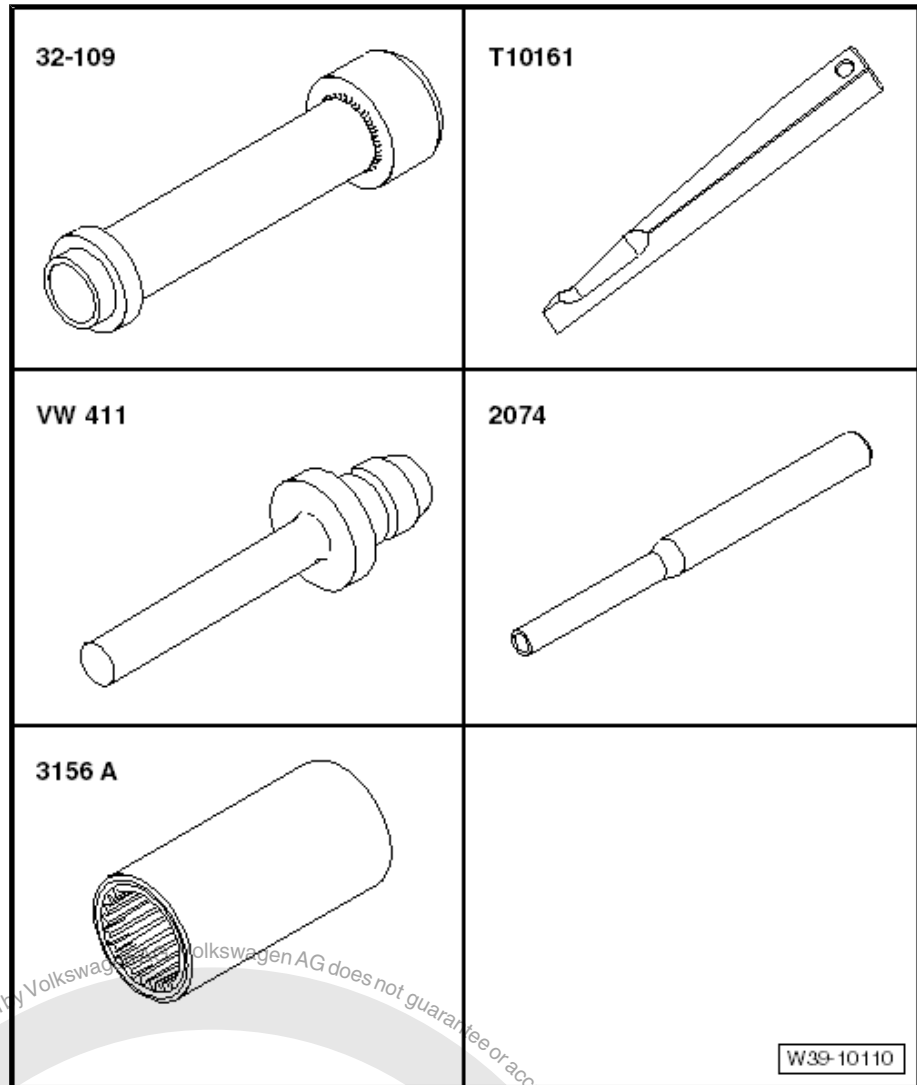

- ◆ Tube - 32 - 109-
- ◆ Wedge - T10161- , qty. 2
- ◆ Press tool - VW 411-
- ◆ Drift - 2074-
- ◆ Socket - 3156 A-

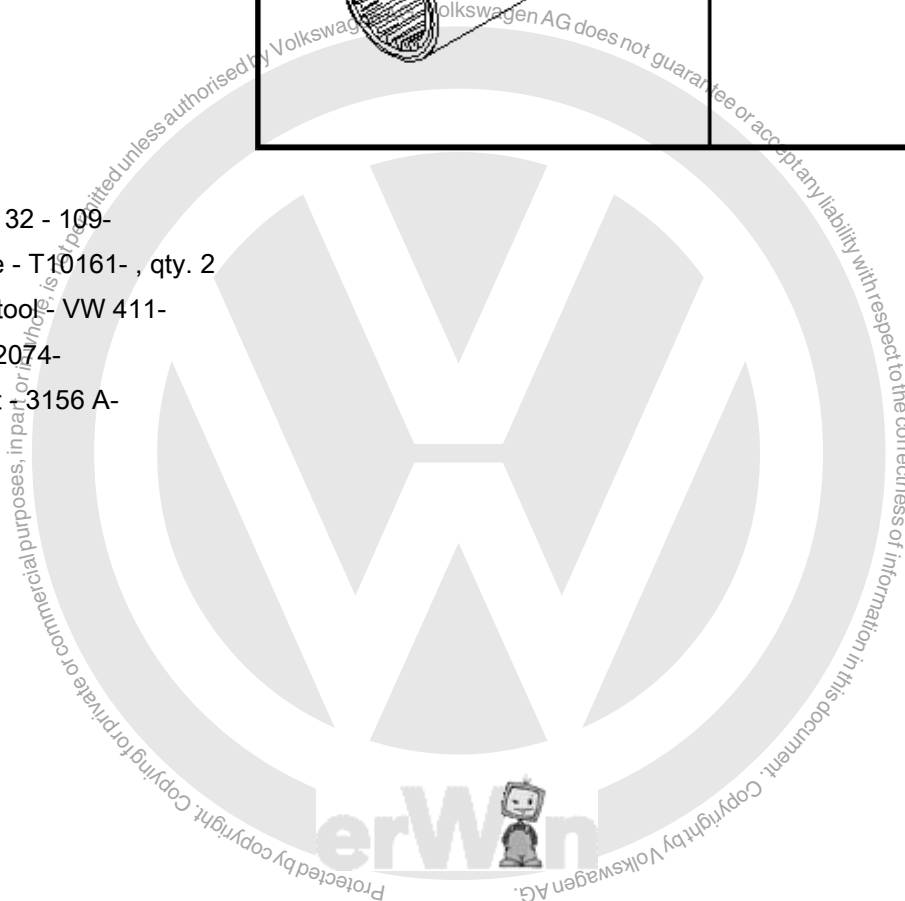



i Note

- ◆ Heat tapered roller bearing inner races to 100°C before installing.
- ◆ Always renew both tapered roller bearings together as a set.
- ◆ If tapered roller bearings, differential cage, gearbox housing or clutch housing is renewed, adjust differential => [page 182](#).

Pulling tapered roller bearing outer race out of clutch housing

A - Counter support - VAS 251 623- or counter support , e.g. -Kukko 22/2-

B - Internal puller - VAS 251 615- , or internal puller 46 ... 58 mm , e.g. -Kukko 21/7-

- Clamp internal puller securely behind tapered roller bearing outer race.

Insert new baffle plate (shown here in conjunction with gearbox housing)

Installation position: shoulder -arrow- faces away from housing

-A-

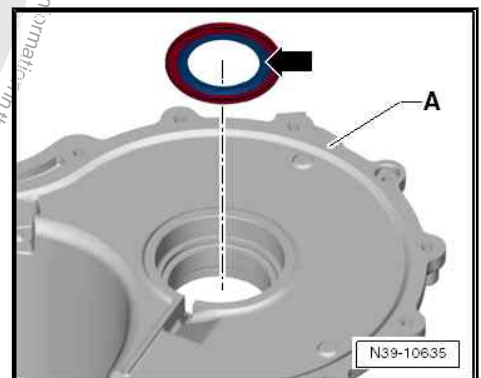
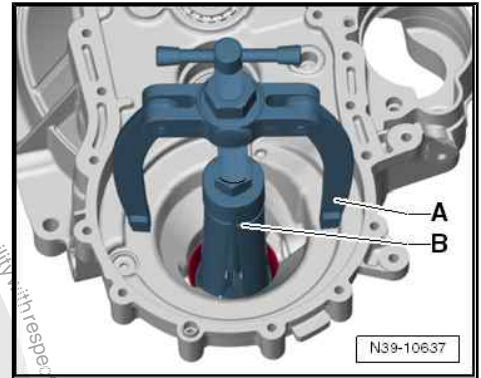

Pressing tapered roller bearing outer race into clutch housing

- Fit counterhold tool - T10140- onto thrust plate - VW 402- .
- Use counterhold tool - T10140- to hold clutch housing in horizontal position.

Instead of counterhold tool - T10140- , an 8 x 280 steel bar can be used.

Larger shoulder of thrust plate - VW 510- faces towards press tool - VW 408 A- .

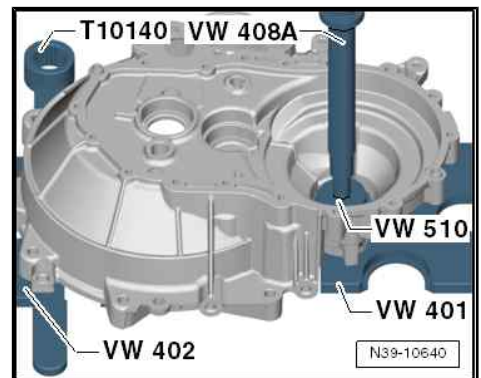

Pulling off tapered roller bearing inner race

- Before fitting extractor, position spacer sleeve - VW 472/2- and thrust piece - 3002- on differential housing.

i Note

Both tapered roller bearing inner races are pulled off the differential cage in the same way.

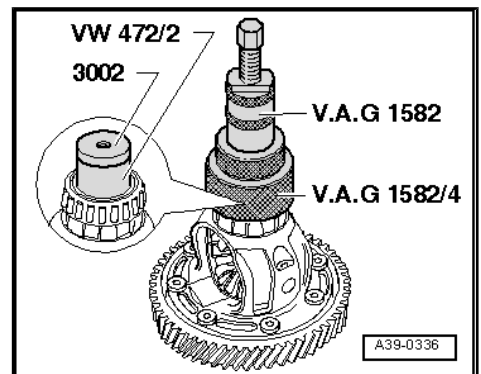



Pressing on tapered roller bearing inner race



WARNING

Wear protective gloves.

- Heat inner tapered roller bearing race to approx. 100°C before pressing on.



Note

Both tapered roller bearing inner races are pressed onto the differential cage in the same way.

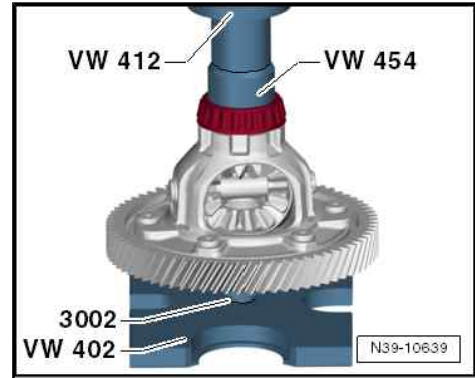

Pulling outer race for tapered roller bearing out of gearbox housing

A - Counter support - VAS 251 623- or counter support , e.g. - Kukko 22/2-

B - Internal puller - VAS 251 615- , or internal puller 46 ... 58 mm , e.g. -Kukko 21/7-

- Clamp internal puller securely behind tapered roller bearing outer race.

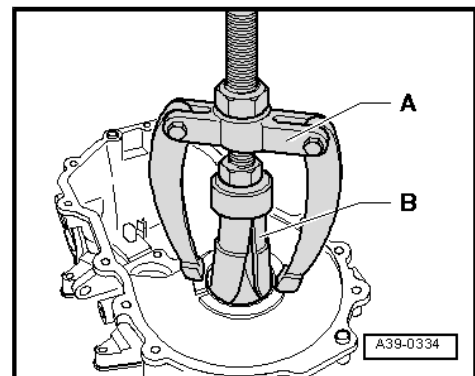

Insert new baffle plate

Installation position: shoulder -arrow- faces away from housing
-A-

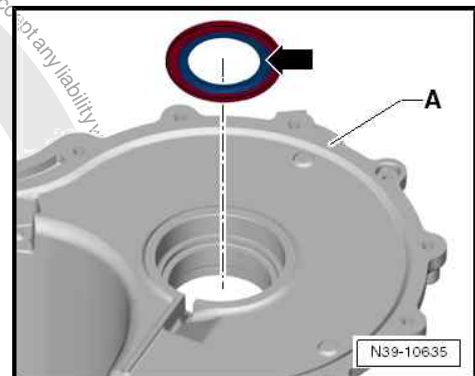



Pressing tapered roller bearing outer race into gearbox housing

Larger shoulder of thrust plate - VW 510- faces towards press tool - VW 412- .

- Support gearbox housing with tube - 32 - 109- directly below bearing support.
- Use wedges - T10161- to hold gearbox housing in horizontal position.

Pulling off tapered roller bearing inner race ⇒ [page 179](#)



Note

Both tapered roller bearing inner races are pulled off the differential cage in the same way.

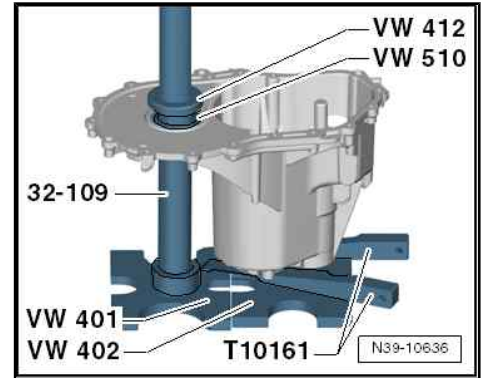

Pressing on tapered roller bearing inner race ⇒ [page 180](#)



Note

Both tapered roller bearing inner races are pressed onto the differential cage in the same way.



WARNING

Wear protective gloves.

- Heat inner tapered roller bearing race to approx. 100°C before pressing on.

Removing differential bevel gears, one-piece thrust washer and differential pinion pin

- Remove retaining ring for differential pinion pin.
- Remove differential pinion pin.
- Drive out differential pinion pin using plastic hammer and fitting drift - 2074- .

If engagement factor is too high, press out differential pinion pin.

- In this case, have a second mechanic hold differential in position.

Splines of socket - 3156 A- point towards differential.

Make sure not to damage splines.

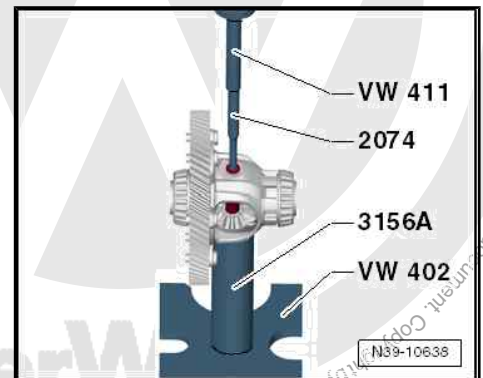

Installing differential bevel gears, one-piece thrust washer and differential pinion pin

- Lubricate one-piece thrust washer with gear oil and install.
- Insert both sun wheels.
- Hold upper sun wheel in position.
- Insert both planet pinions offset 180° and pivot into position.
- Drive in differential pinion pin -arrow- until it reaches its final position, and secure it with retaining ring.

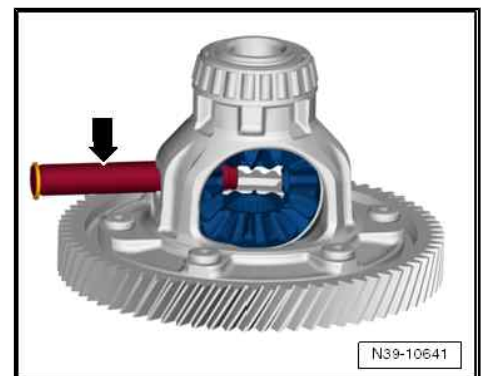



2.3 Adjusting differential

Special tools and workshop equipment required

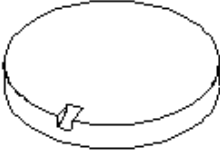
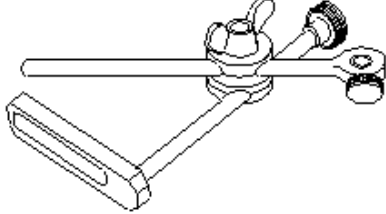
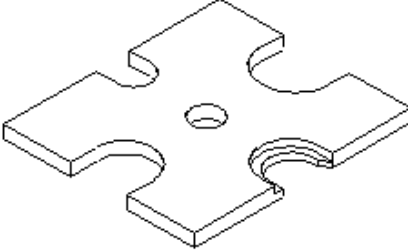
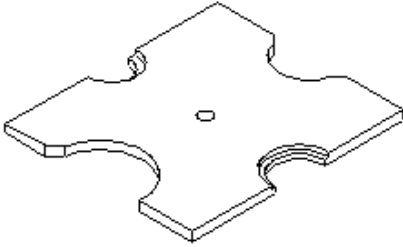
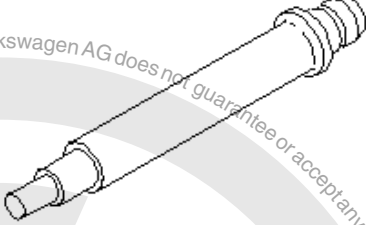
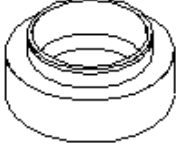
<p>VW 385/17</p> 	<p>VW 387</p> 
<p>VW 401</p> 	<p>VW 402</p> 
<p>VW 408 A</p> 	<p>VW 510</p>  <p style="text-align: right;">W39-10111</p>

- ◆ Support clamp - VW 313-
- ◆ Gearbox support - T10484-
- ◆ End dimension plate - VW 385/17-
- ◆ Universal dial gauge holder - VW 387-
- ◆ Thrust plate - VW 402-
- ◆ Thrust plate - VW 401-
- ◆ Press tool - VW 408-
- ◆ Thrust plate - VW 510-
- ◆ Torque wrench - V.A.G 1331-
- ◆ Dial gauge - VAS 6080A-
- ◆ 30 mm dial gauge extension





- ◆ Internal puller - VAS 251 615- , or internal puller 46 ... 58 mm , e.g. -Kukko 21/7-

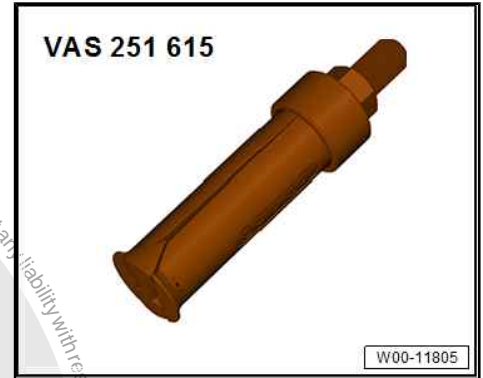

- ◆ Counter support - VAS 251 623- or counter support , e.g. - Kukko 22/2-



It is necessary to readjust the differential when the following components are renewed:

- ◆ Gearbox housing
- ◆ Clutch housing
- ◆ Differential cage
- ◆ Tapered roller bearing of differential

Requirement:

- Sealing surfaces of clutch and gearbox housings must be free of sealant .
- Both tapered roller bearings inner races are pressed onto differential cage ⇒ [page 180](#) .
- New baffle plate is inserted into gearbox housing ⇒ [page 180](#) .
- Tapered roller bearing outer race (gear wheel side) is pressed into gearbox housing ⇒ [page 181](#) .

Adjustment overview ⇒ [page 185](#)

- Press tapered roller bearing outer race (opposite side of gear wheel) without shim and without baffle plate into clutch housing ⇒ [page 179](#) .
- Insert differential in gearbox housing.
- Fit clutch housing and tighten 5 bolts to specified torque ⇒ [Item 3 \(page 117\)](#) .

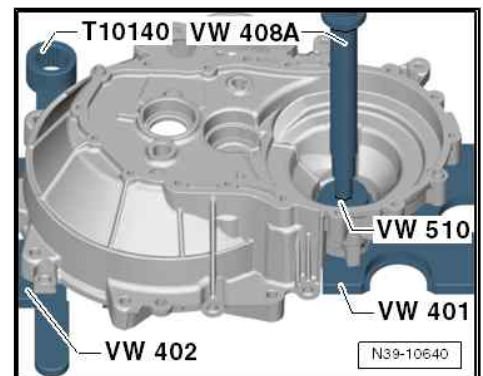



- Fit dial gauge, and set it to "0" with 1 mm preload.
- A - 30 mm dial gauge extension
- Before taking any measurements, rotate differential to allow tapered roller bearings to settle. Set dial gauge to "0" with 1 mm preload.
- Move differential up and down. Read and note play indicated on dial gauge. (Example: 1.50 mm)

Determining thickness of shim

The specified bearing preload is obtained by adding a constant value for preload (0.20 mm) to the reading obtained.

Example:

Measured value	1.30 mm
+ Preload (constant)	0.20 mm
Thickness of shim =	1.50 mm

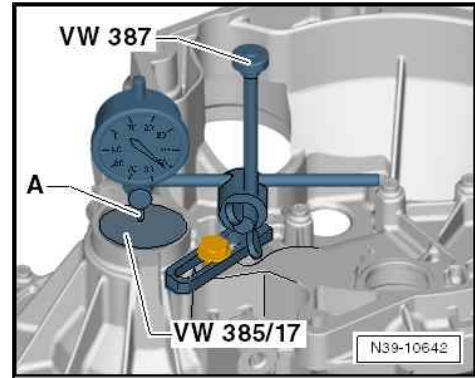

- Remove gearbox housing, and pull tapered roller bearing outer race out of clutch housing ⇒ [page 179](#) .

A - Counter support - VAS 251 623- or counter support , e.g. - Kukko 22/2-

B - Internal puller - VAS 251 615- , or internal puller 46 ... 58 mm , e.g. -Kukko 21/7-

- Allocate shim(s) using ⇒ Electronic parts catalogue (ETKA) .

The various thicknesses make it possible to achieve the exact shim thickness required.

If the size of shim required is larger than those listed in the ⇒ Electronic parts catalogue (ETKA) , insert two shims totalling the correct figure.

- Insert new baffle plate ⇒ [page 180](#) .
- Insert shim of determined thickness (in example 1.50 mm), and press tapered roller bearing outer race back into clutch housing ⇒ [page 179](#) .
- Fit clutch housing and tighten bolts to specified torque.

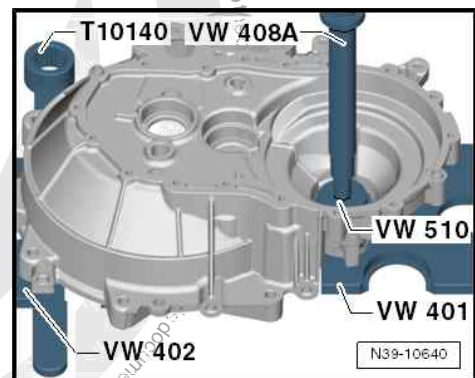
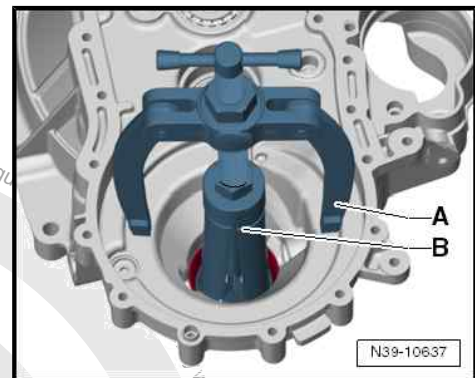



3 Adjustment overview



Note

Adjustment of the input shaft, output shaft, or differential is only necessary if components have been renewed which have a direct effect on the adjustment of the gearbox. To prevent unnecessary adjustments, refer to the following table:

		To be adjusted:		
		Input shaft ⇒ page 144	Output shaft ⇒ page 165	Differential ⇒ page 182
Parts renewed:	Gearbox housing	x	x	x
	Clutch housing	x	x	x
	Input shaft	x		
	Output shaft		x	
	Differential cage			x
	Input shaft tapered roller bearing	x		
	Tapered roller bearing for output shaft		x	
	Tapered roller bearing for differential			x

