

NEW
6-Speed Manual Gearbox 02M
for
OCTAVIA
4X4

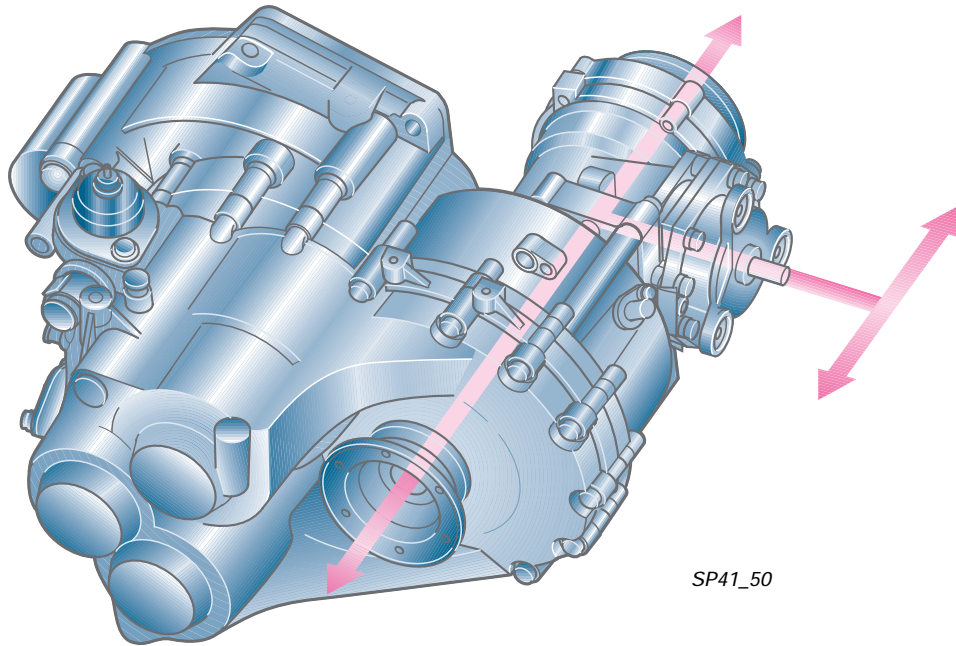

SP41_50

Ever greater demands are made on modern cars in terms of function, driving comfort, safety, environmental compatibility and also their suitability for a sporty style of driving. That is a reason why cars undergo permanent further development and evolution. In addition to many other technical components this also is true for the gearbox.

Gearboxes with more gears are, for example, quieter running and can be better adapted to the properties of different engines. By more effectively exploiting the available torque, they also indirectly contribute to a reduction in pollutant emissions.

The 6-speed manual gearbox 02M is such a new development.

It is a compact gearbox for transverse installation in the engine with 6 forward gears, adapted to four-wheel drive 4x4.

The compact design has been achieved by using 1 input shaft and 2 output shafts.

You can find out more regarding design and function of the gearbox in this Self Study Programme.

Contents

■	Introduction	4
■	Gearbox Mechanical Components	6
	Design	6
	The housing	8
	Diagram of gearbox	10
	The input shaft	12
	The 1st output shaft	13
	The 2nd output shaft	14
	The reverse idler shaft	15
	Differential and bevel box	16
	The double mesh	18
	Clutch control	20
	Power flow	22
■	Shift Mechanism	24
	External shift mechanism	24
	Internal shift mechanism	26
	The selector movement	27
	The shift movement	28
	The reverse gear lock	29
■	Sensors	30
	Indication of vehicle speed	30
	Reversing light switch F4	31
■	Test Your Knowledge	32

ŠKODA



You will find notes on inspection and maintenance, setting and repair instructions in the Workshop Manual.

Protected by copyright. Copying for private use is permitted by SKODA AUTO A. S. ŠKODA reserves the right to change technical specifications without notice. All rights reserved. ŠKODA is a registered trademark of SKODA AUTO A. S. ŠKODA is a registered trademark of SKODA AUTO A. S. ŠKODA is a registered trademark of SKODA AUTO A. S.



Introduction

General

What advantages does a 6-speed gearbox offer?

Several reasons exist for using a gearbox with more than 5 forward gears.

- Gearbox and engine can be better matched to each other.
- The maximum engine torque is more effectively converted into acceleration.
- The engine can be operated in the rpm range offering the best economy.
- Improved fuel consumption is reflected in reduced exhaust emissions, which in turn contribute to an improvement in environmental compatibility.
- A higher level of driving comfort is achieved by improving the smooth running.
- 6-speed gearboxes combined with powerful engines also permit a sporty style of driving.

6-speed gearbox permits better

ŠKODA

Engine-gearbox harmonisation



Utilisation of economic rpm ranges

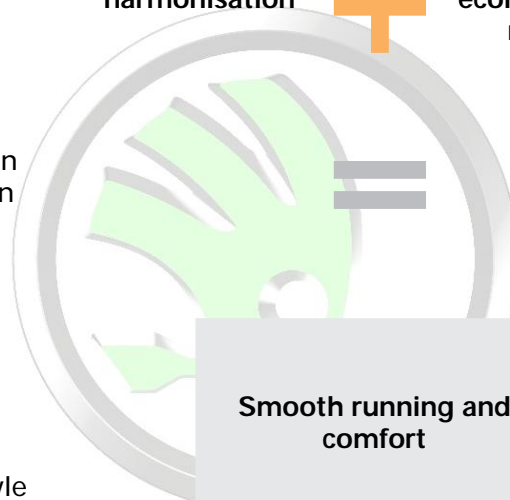

Smooth running and comfort

Protected by copyright. Copying for private or commercial purposes, in part or in whole, is not permitted unless authorised by ŠKODA AUTO A. S. ŠKODA AUTO A. S. does not guarantee or accept any liability with respect to the correctness of information.

Improved fuel consumption

Reduced exhaust emissions

Sporty style of driving

Brief technical description

- Gearbox designation: 02M
- Input shafts: 1
- Output shafts: 2
- Forward gears: 6
- Reverse gears: 1
- Maximum input torque: 350 Nm
- Type of installation: transverse
- Hydraulic clutch control - slave cylinder and release bearing form a single unit.
- Internal shift mechanism using shift shaft and shift rods with shift forks.
- Standardised cable shift mechanism.
- Gear oil: filled for life - no change

Data sheet

Manually-operated 6-speed gearbox for 4x4	Ratio i =	No. of teeth of driven gear z_2	
		No. of teeth of driving gear z_1	
Gearbox code	FBS		
Engine assignment	1,9 l/74 kW TDI		
	z_2	z_1	i
1st gear	42	11	3,818
2nd gear	40	19	2,105
3rd gear	38	29	1,310
4th gear	34	37	0,919
5th gear	31	34	0,912
6th gear	28	27	0,757
Reverse	23 31	14 11	4,630
Final drive 1st output shaft	63	15	4,200
Final drive 2nd output shaft	63	19	3,316
Detection of distance driven and vehicle speed	electronic		
Gear oil specification	G51 SAE 75W90 (synthetic oil)		
Gear oil change	filled for life		
Clutch control	hydraulic		
Assignment of rear final drive/Code	EUL		

The gearbox with gearbox code FBS is assigned in this case to engine 1.9 l/74 kW TDI.

The gear steps have been specifically harmonised to this engine.



Note:
The gearbox code letters are also listed in the data stickers of the vehicle.

Gearbox Mechanical Components

Design

In a conventional gearbox it is the input shaft which transmits the torque to an output shaft on which the various shift gears for the individual gear steps are arranged. The more shift gears there are arranged on a gearbox shaft, the longer it becomes and the longer also is the gearbox itself.

In the case of a so-called compact gearboxes which also includes the manual gearbox 02M, use is made of not only one, but two output shafts.

This makes it possible to significantly reduce the overall length, and at the same time to achieve savings in terms of material and costs.

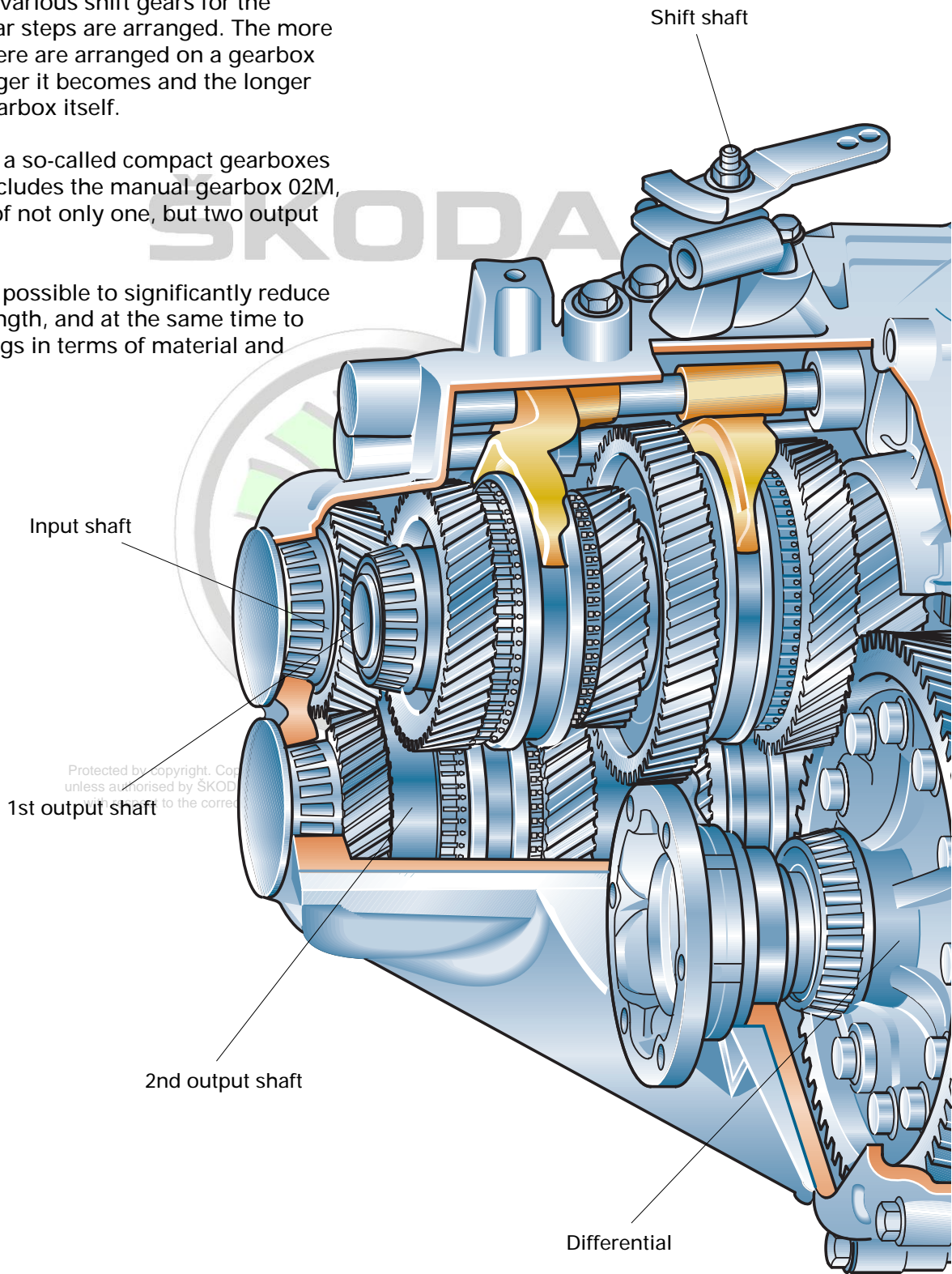

The shift gears for the individual speeds are distributed over the two output shafts as follows:

- 1st output shaft forward gears 1 to 4
- 2nd output shaft forward gears 5, 6 and reverse

Reverse gear also includes a reverse idler shaft with two gearwheels which reverse the direction of rotation (in the illustration the reverse idler shaft is concealed by the input shaft).

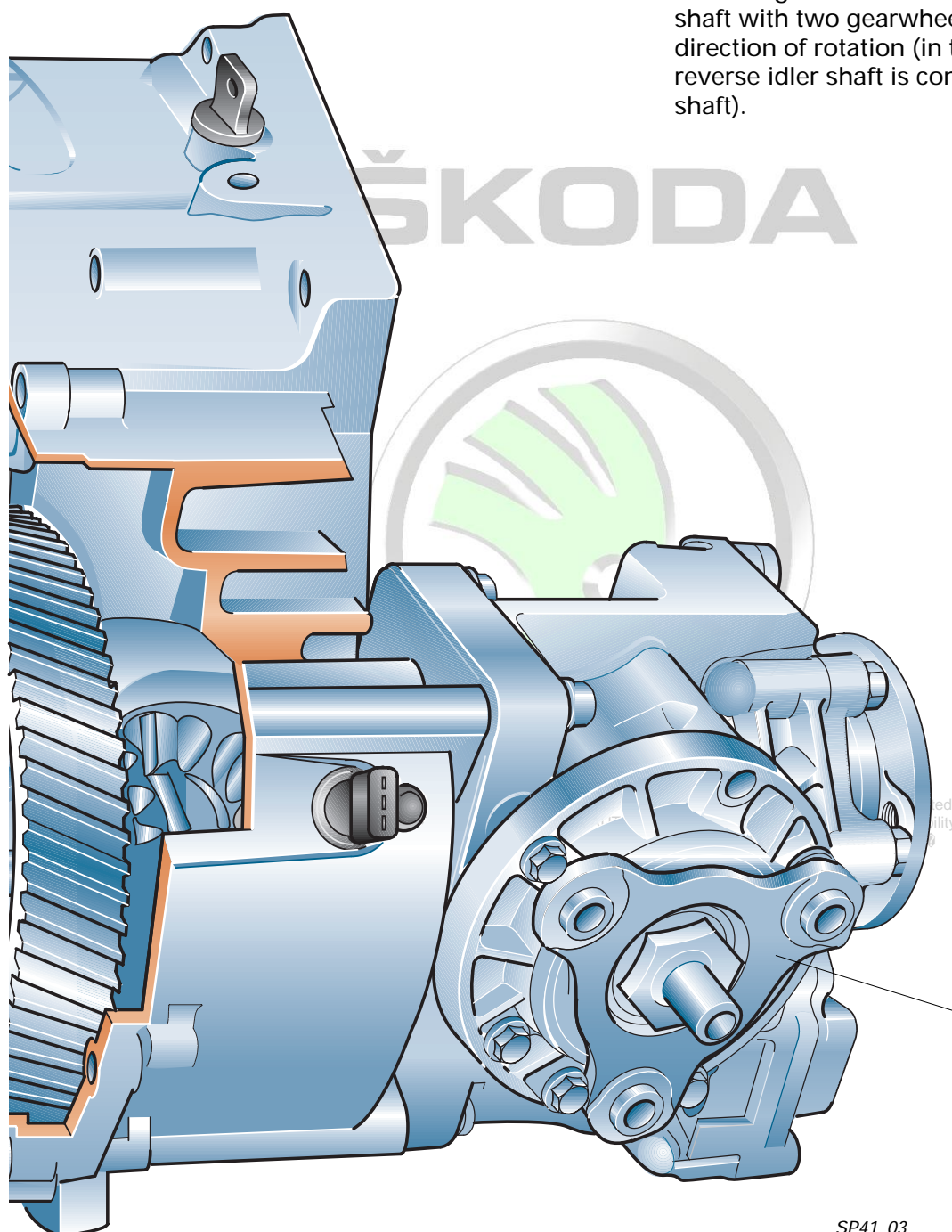

Bevel box for four-wheel drive 4x4

SP41_03

Gearbox Mechanical Components

The housing

consists of 3 principal components (gearbox housing, clutch housing and the housing for the bevel box).

The shift cover seals off the gearbox housing to the top.

In order to achieve a lightweight construction, all of the housing components are manufactured from a magnesium/aluminium alloy.



Note:
You can find detailed information regarding the conditions which must be observed when using parts manufactured from magnesium, in the Self Study Programme No. 37.

Housing for bevel box

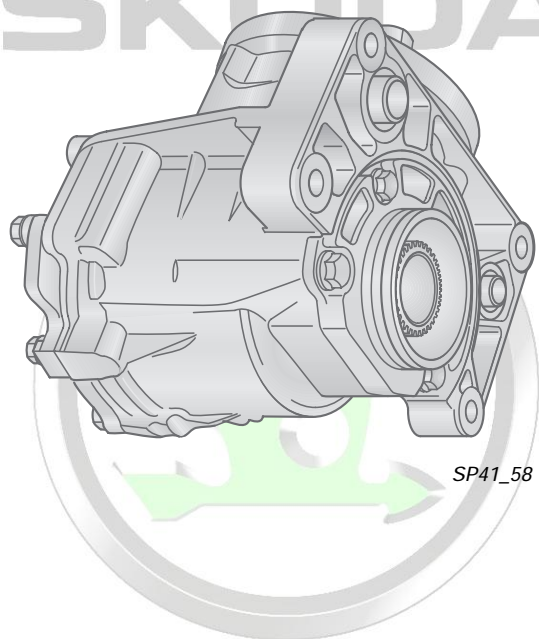

Clutch housing

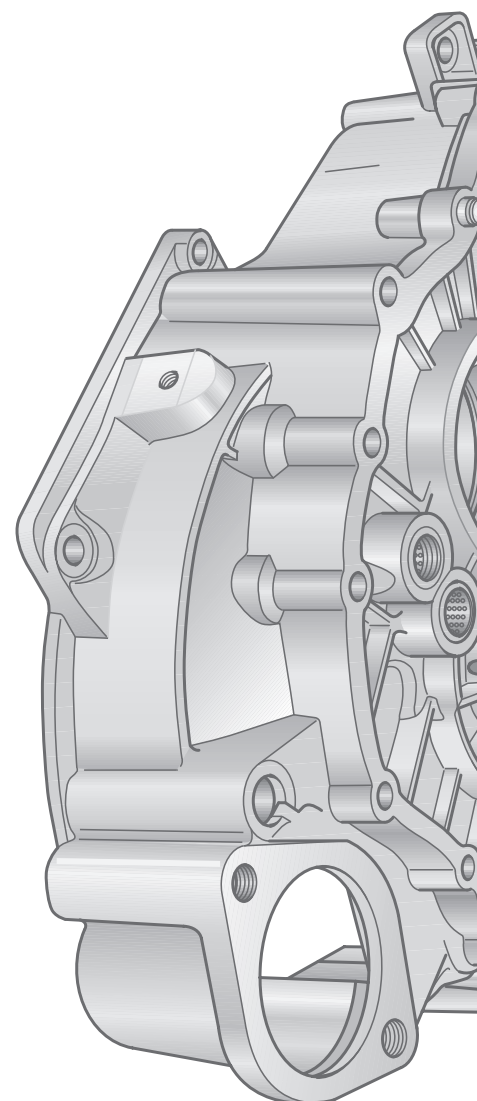

Shift cover

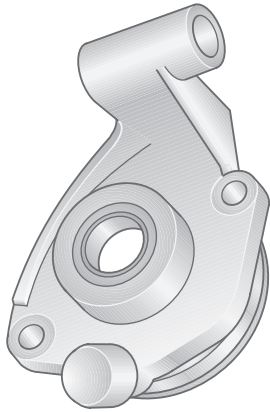

SP41_59

Gearbox housing

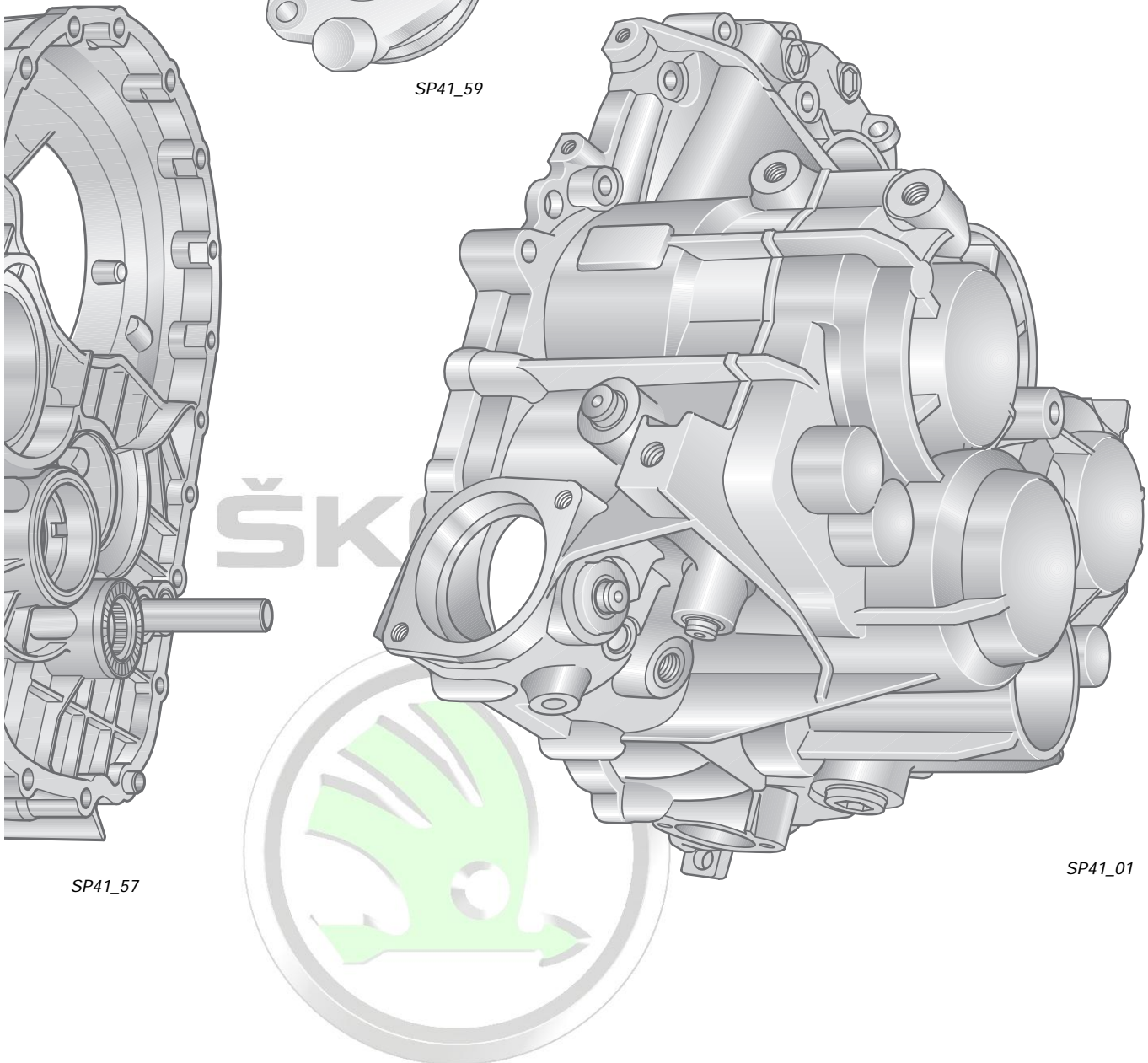

SP41_57

SP41_01

Gearbox Mechanical Components

Diagram of gearbox

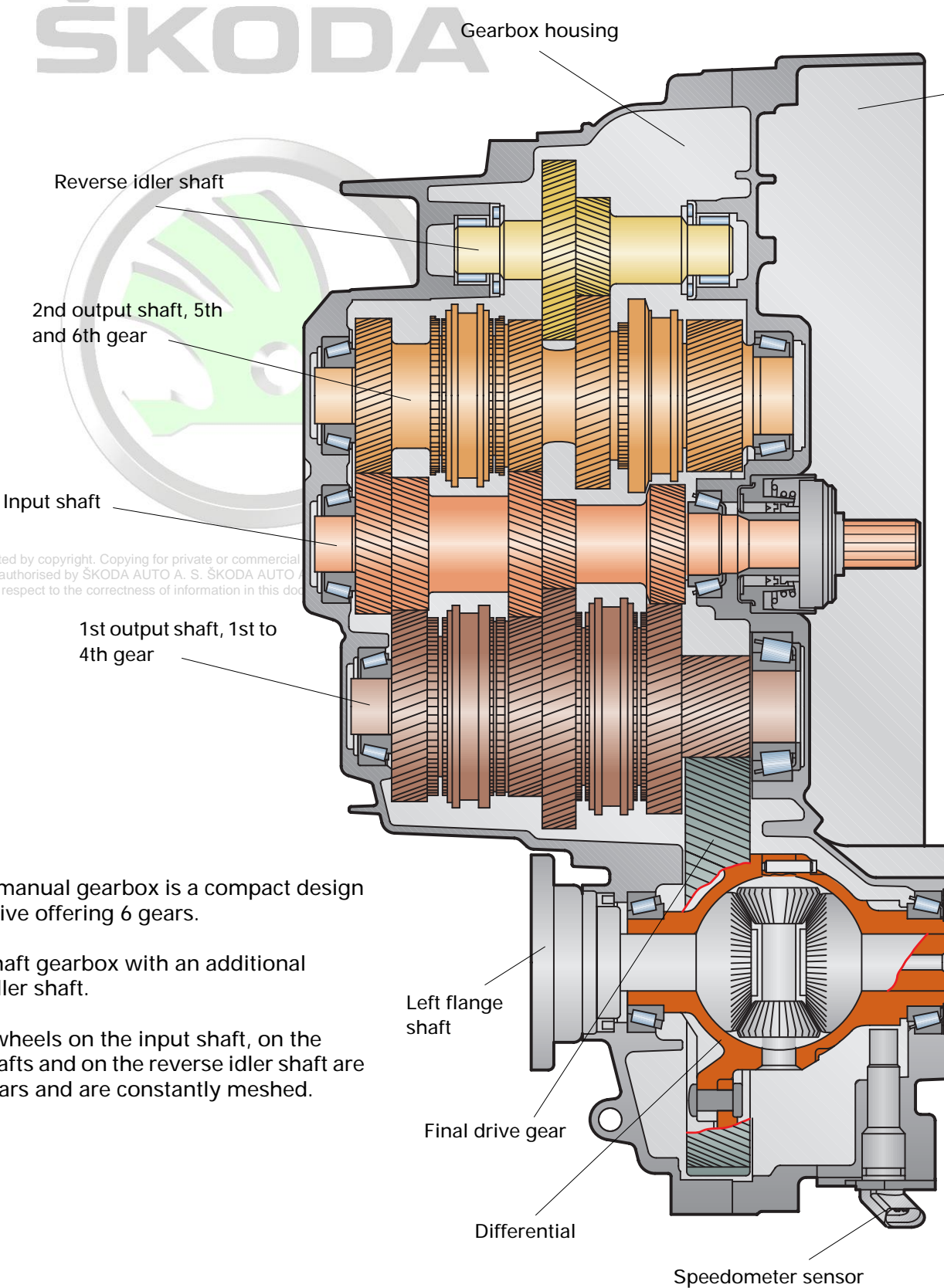

Protected by copyright. Copying for private or commercial use without authorised by ŠKODA AUTO A. S. ŠKODA AUTO reserves the right to change specifications without respect to the correctness of information in this document.

The 02M manual gearbox is a compact design for 4x4 drive offering 6 gears.

It is a 3-shaft gearbox with an additional reverse idler shaft.

The gearwheels on the input shaft, on the output shafts and on the reverse idler shaft are helical gears and are constantly meshed.

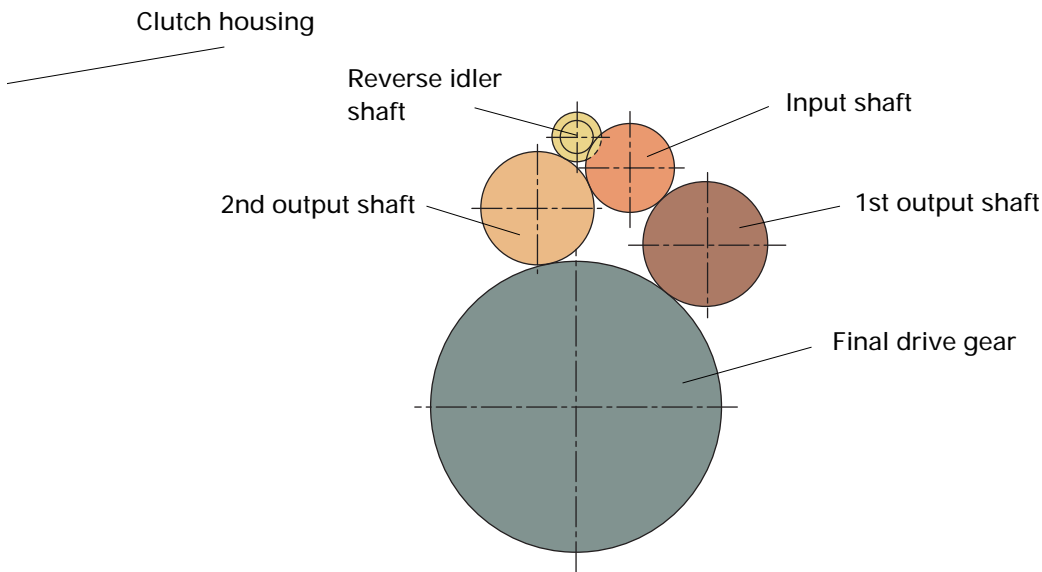

Diagram of positions of shafts



Note:
The diagram of the gearbox illustrates shafts in one plane.

1st to 4th gear are shifted on the 1st output shaft, 5th and 6th gear on the 2nd output shaft. Reverse gear is shifted on the 2nd output shaft.

All the forward gears as well as reverse are synchronised.

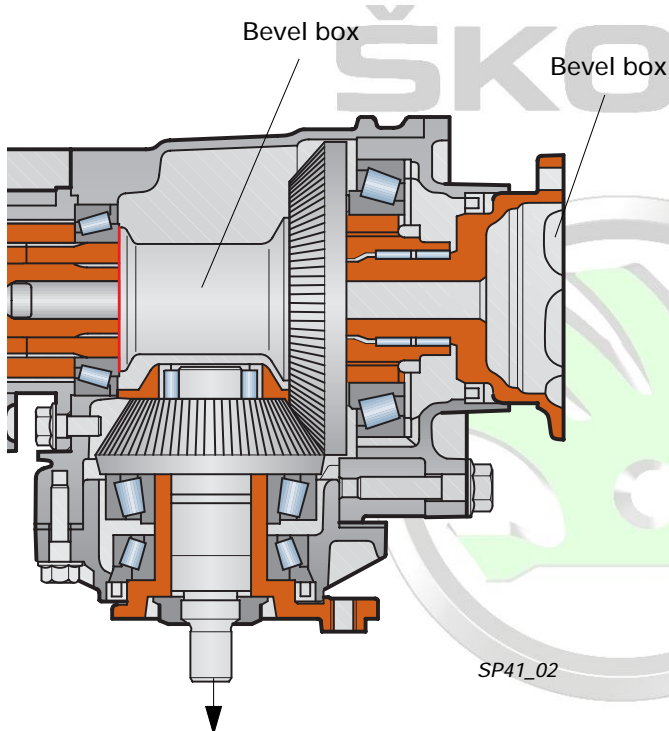

The torque is transmitted through one of the two output shafts to the final drive gear, the differential and on from there through the left and right flange shafts to the front wheel drive.

For four-wheel drive the torque is transmitted through the bevel box, the adjoining propshaft and a Haldex clutch to the rear final drive.



Note:
You can find detailed information regarding the 4x4 drive train with Haldex clutch in SSP 29.

Protected by copyright. Copying for private or commercial purposes, in part or in whole, is not permitted unless authorised by ŠKODA AUTO A. S. ŠKODA AUTO A. S. does not guarantee or accept any liability with respect to the correctness of information in this document. Copyright by ŠKODA AUTO A. S.

Gearbox Mechanical Components

The input shaft

The input shaft is mounted in a taper roller bearing both in the clutch housing as well as in the gearbox housing.

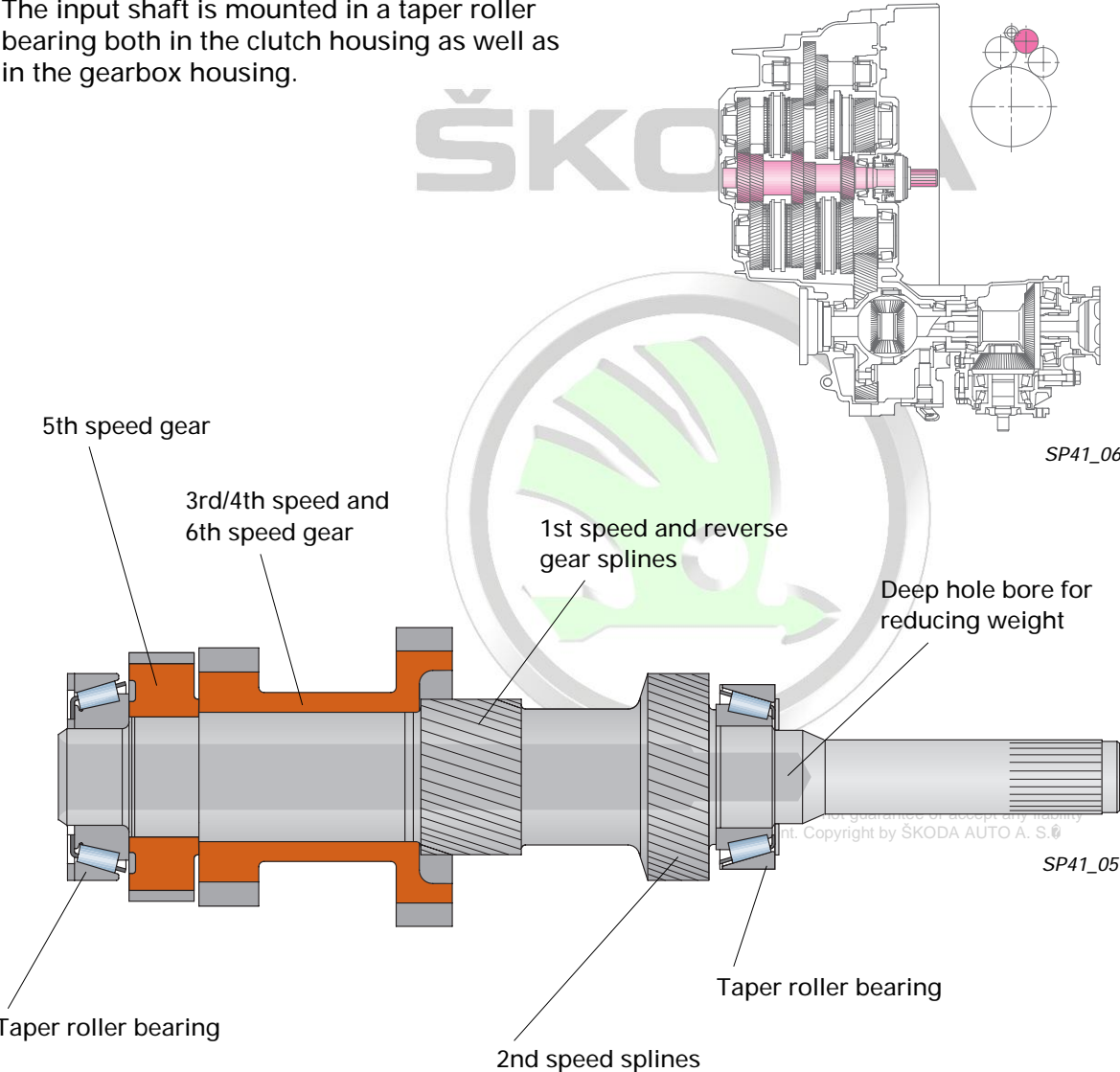

The splines for 1st, 2nd and reverse gear are part of the input shaft. The gearwheels for 3rd to 6th speed are shrink-fitted to form a fixed part of the input shaft.

The input shaft has a deep hole bore to reduce weight.

The 1st output shaft

In the same as the input shaft, it is mounted in a taper roller bearing both in the clutch housing and in the gearbox housing.

The shaft has a bore extending axially with the aim of reducing weight.

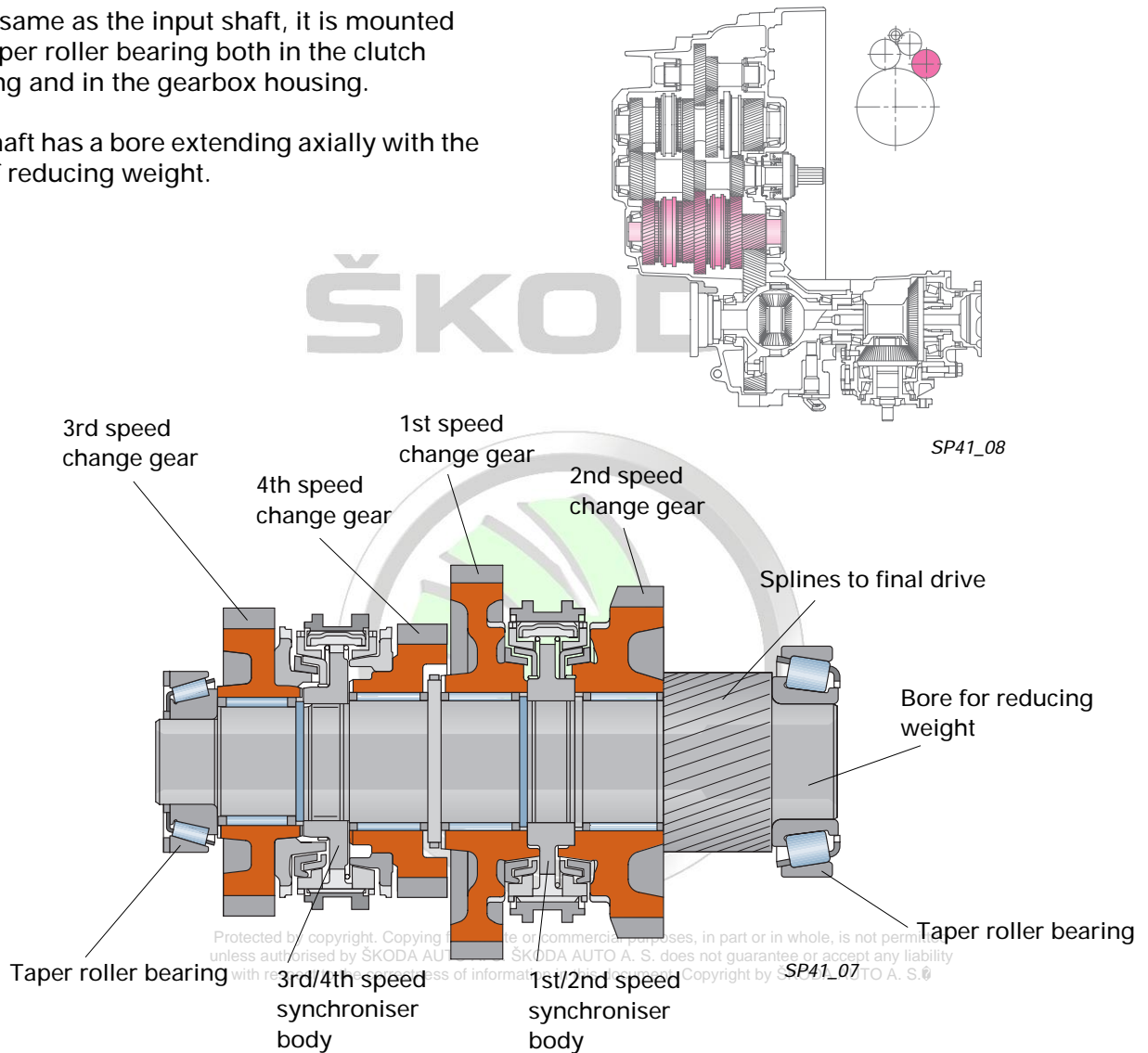

The splines to the final drive are part of the output shaft.

The gears of 1st to 4th speed are loose (which is why they are also known as "movable gears") and run in needle bearings. By virtue of their function they are also known as shift gears.

The two synchroniser bodies of 1st/2nd and 3rd/4th gear are firmly connected to the output shaft by longitudinally slotted splines. Retaining rings hold them in their position.

The movable gears of the output shaft are constantly meshed with the matching splines of the input shaft. In view of the fact, however, that they are not firmly connected to the output shaft so long as no gear is engaged, they do not transmit any torque in this state.

As soon as one of the gears is engaged, the corresponding movable gear is connected to the output shaft.

Gearbox Mechanical Components

The 2nd output shaft

It too runs in a taper roller bearing both in the clutch housing as well as in the gearbox housing.

The 2nd output shaft has a bore running continuously axially to reduce weight.

ŠKODA

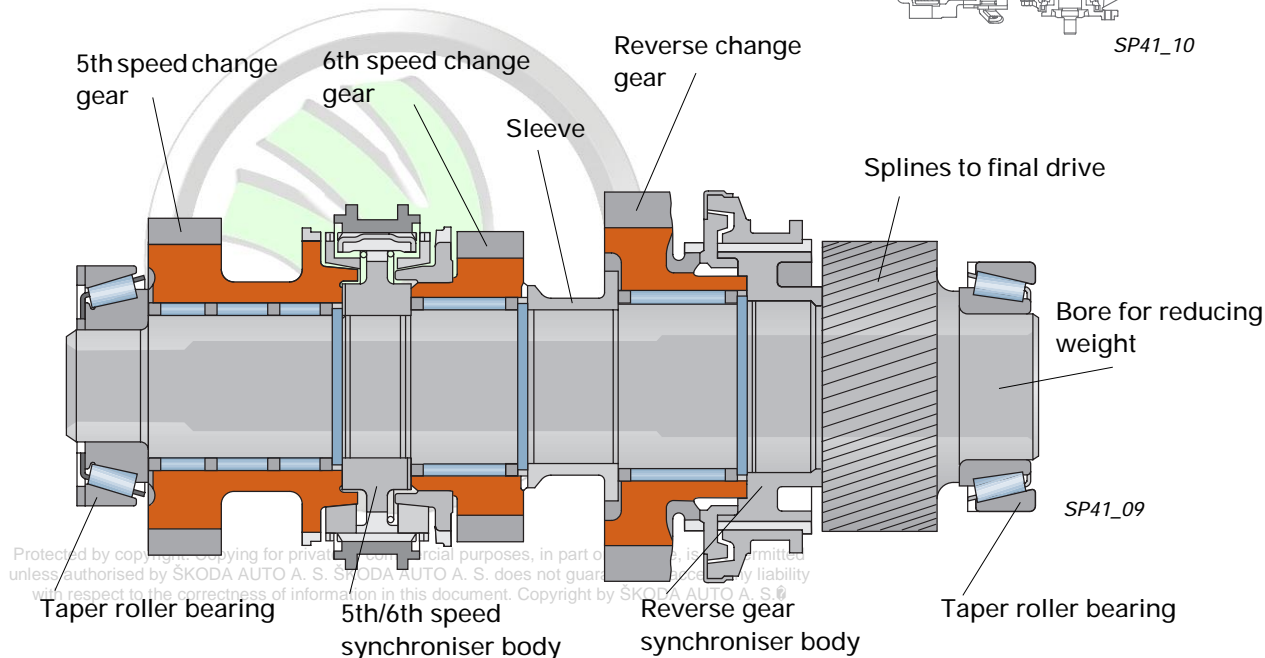
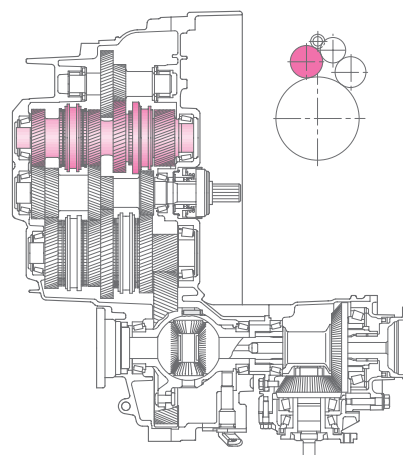

The splines to the final drive are part of the output shaft.

The gears of 5th and 6th speed and reverse gear are loose (which is why they are also known as "movable gears") and run in needle bearings. By virtue of their function they are also known as shift gears.

The synchroniser bodies of 5th and 6th and reverse gear are firmly connected to the output shaft by longitudinally slotted splines. Retaining rings hold them in their position.

The movable gears of the output shaft are constantly meshed with the matching splines of the input shaft. In view of the fact, however, that they are not firmly connected to the output shaft so long as no gear is engaged, they do not transmit any torque in this state.

As soon as one of the gears is engaged, the corresponding movable gear is connected to the output shaft.

The reverse idler shaft

The reverse idler shaft for reverse gear is mounted in a needle sleeve both in the clutch housing and in the gearbox housing.

The reverse idler shaft has a bore running through axially for reducing weight.

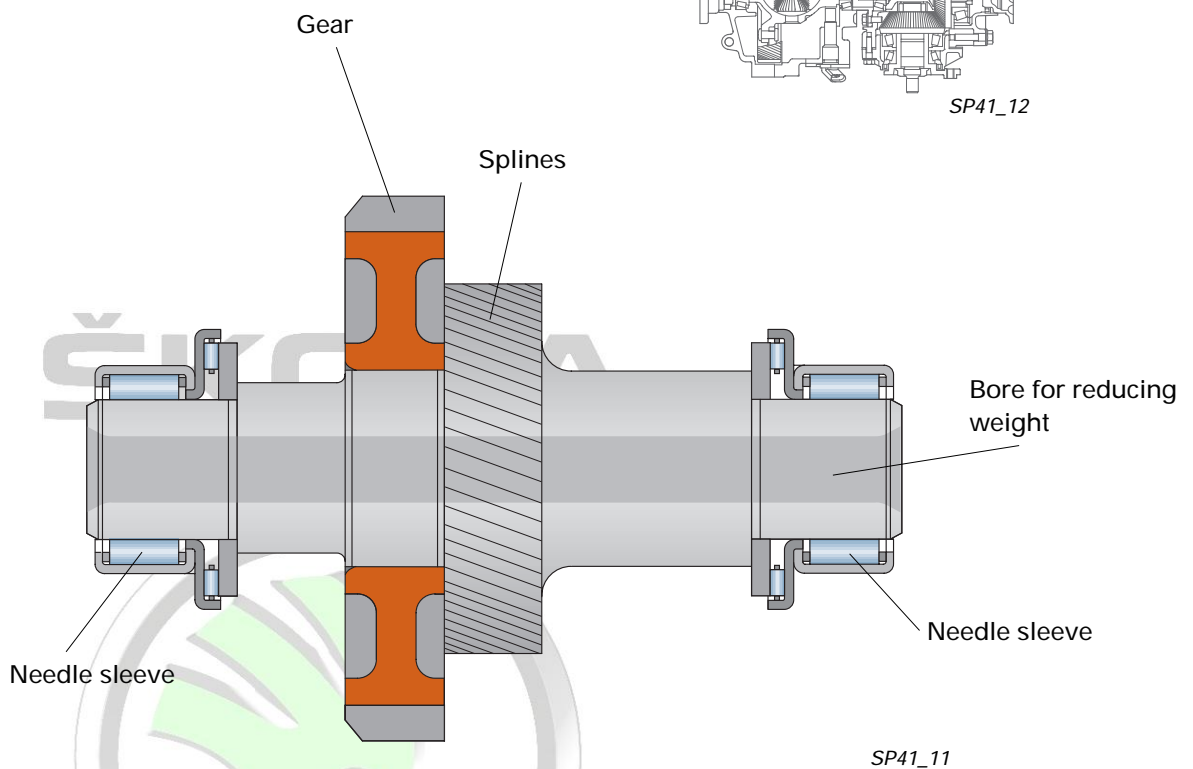
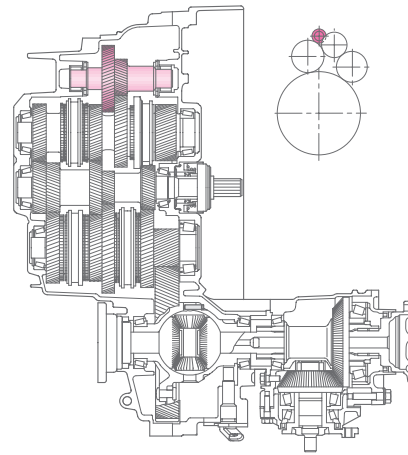

The reverse idler shaft is provided with the splines for reverse gear and a gearwheel which is firmly connected to the shaft by shrink-fitting.

Protected by copyright. Copying for private or commercial purposes, in part or in whole, is not permitted unless authorised by ŠKODA AUTO A. S. ŠKODA AUTO A. S. does not guarantee or accept any liability with respect to the correctness of information in this document. Copyright by ŠKODA AUTO A. S.

Gearbox Mechanical Components

Differential and bevel box

The differential, together with the manual gearbox and the bevel box, form a single unit.

It is mounted in taper roller bearings in the gearbox housing and clutch housing.

The gearbox housing is sealed to the outside at the left flange shaft by means of a sealing ring.

The bevel box forms the end cover at the opposite side.

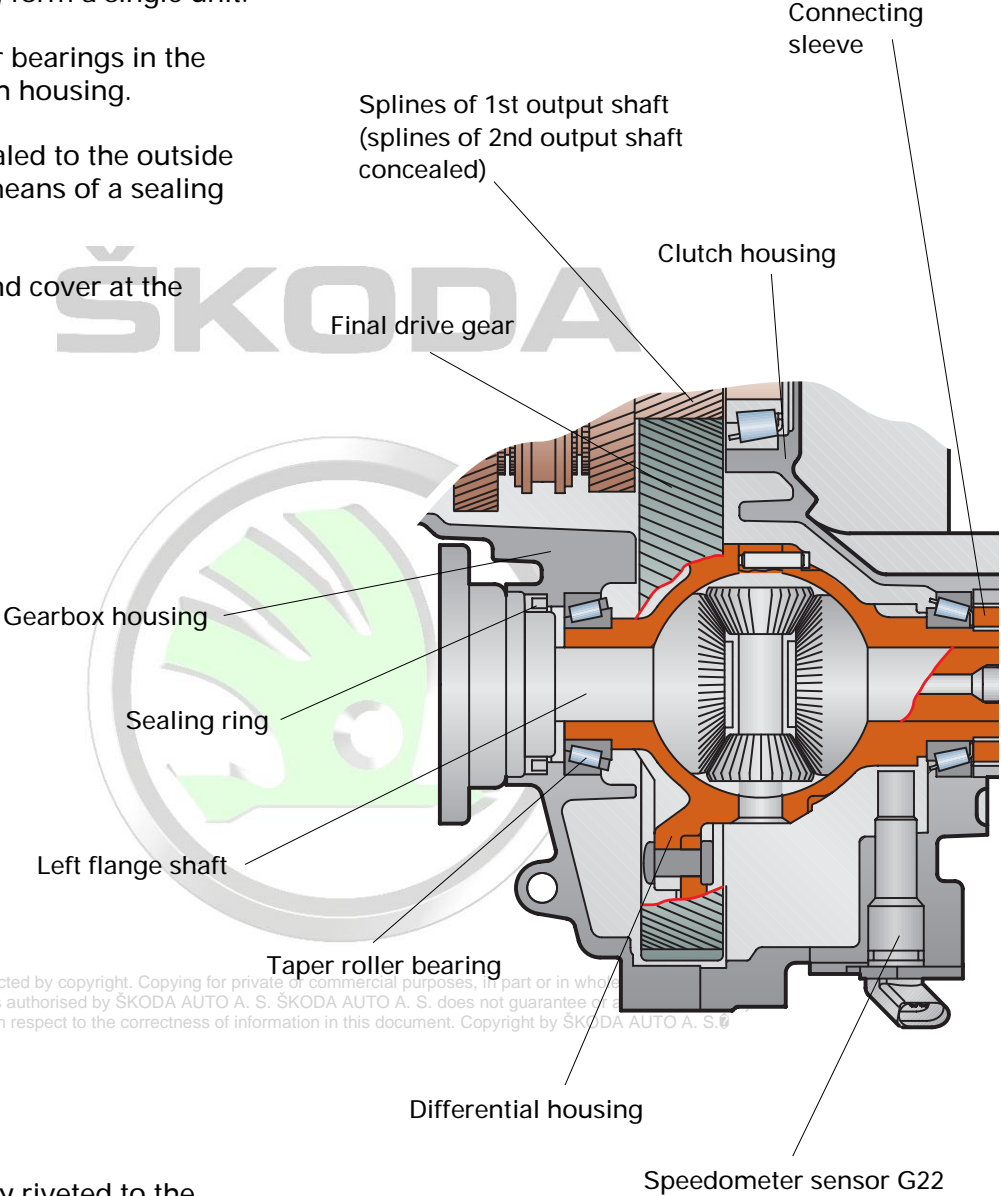

The final drive gear is firmly riveted to the differential housing and is constantly meshed with the splines of the two output shafts.



Note:
Always refer to the information in the Workshop Manual for setting operations at the bevel box.

The bevel box features two flanges positioned at right angles to each other:

- the right flange shaft for the front-wheel drive and
- the output flange pointing toward the rear axle for driving the propshaft (rear final drive).

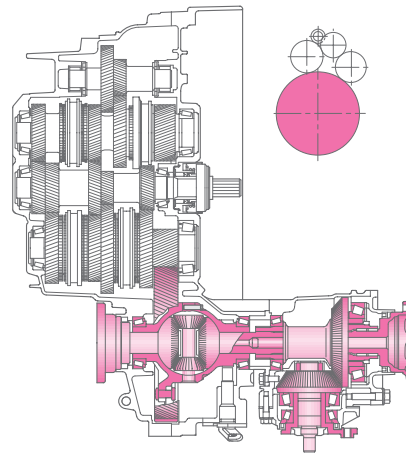
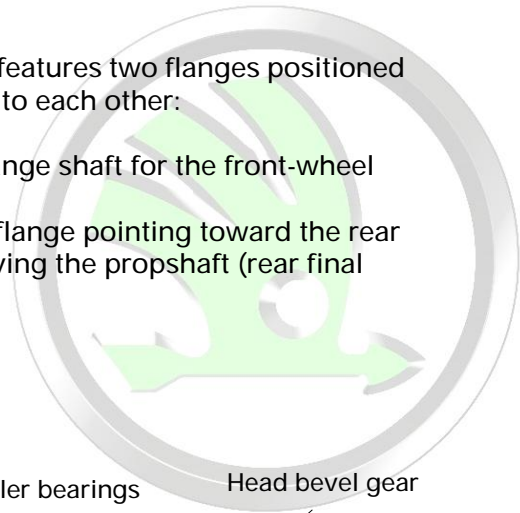

Protected by copyright. Copying for private or commercial purposes, in part or in whole, is not permitted unless authorised by ŠKODA AUTO A. S. ŠKODA AUTO A. S. does not guarantee or accept any liability with respect to the correctness of information in this document. Copyright by ŠKODA AUTO A. S. ©

SP41_16

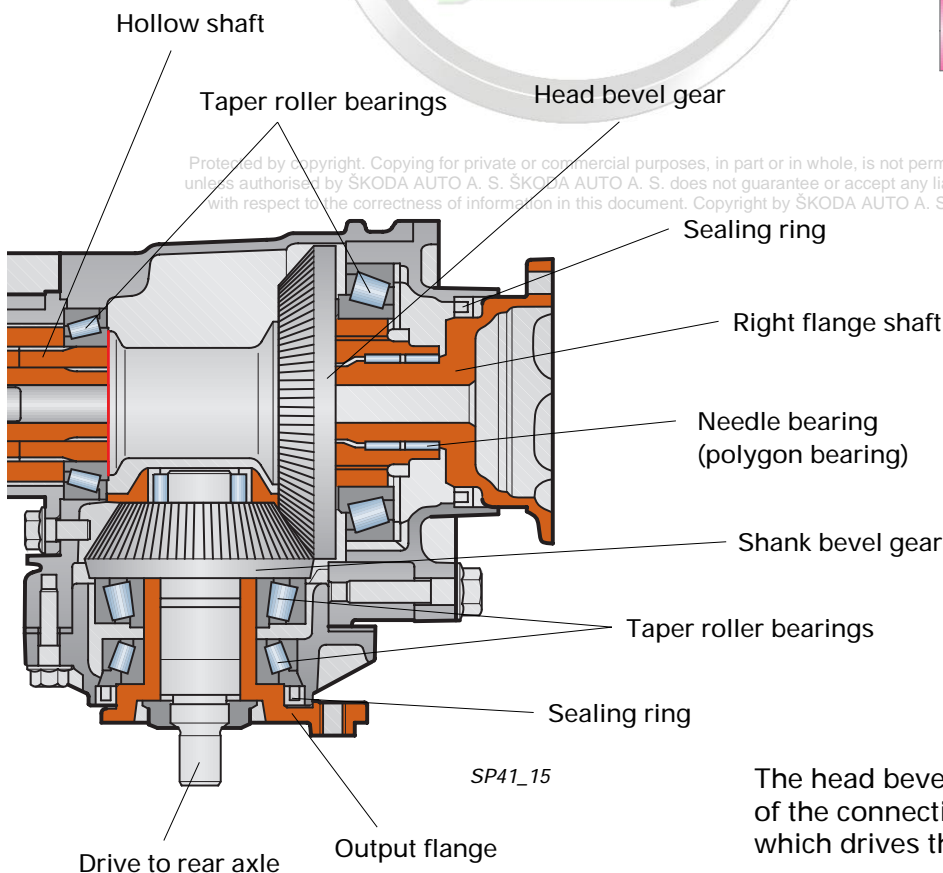

SP41_15

The head bevel gear is connected by means of the connecting sleeve to the differential, which drives the former.

It in turn is meshed at right angles to the shank bevel gear and directs the power flow from the differential on to the rear axle.

The right flange shaft is longer than the left flange shaft. It is connected on the left to the differential and its shank runs in a needle bearing (polygon bearing) in the bevel box.

The bevel box is sealed to the outside at the right flange shaft and at the output flange for the rear-wheel drive by means of sealing rings.

Gearbox Mechanical Components

The double mesh

Replacing the single output shaft conventionally fitted to a gearbox by two output shafts of a more compact design, is in itself not sufficient to achieve a particularly compact design of gearbox.

It also calls for a simple technical solution for transmitting the torque to the two output shafts.

This task on the 02M gearbox is solved by employing the so-called "double mesh".



Note: Using the double mesh makes it possible to transmit the force for 2 gears at a time with only one set of splines of the input shaft.

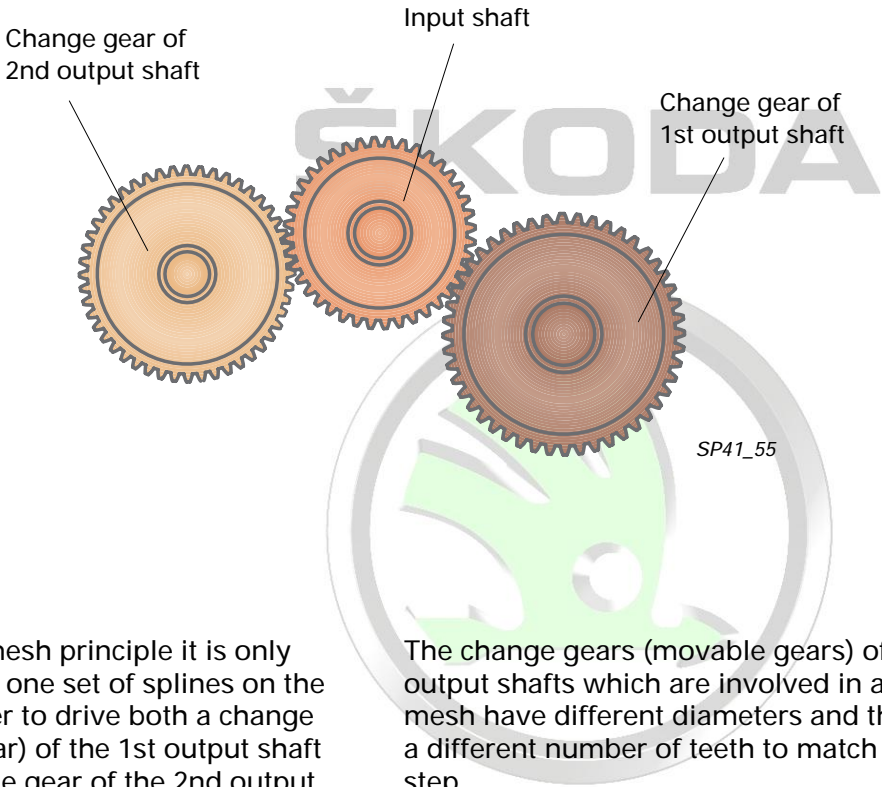

With the double mesh principle it is only necessary to have one set of splines on the input shaft in order to drive both a change gear (movable gear) of the 1st output shaft as well as a change gear of the 2nd output shaft (in the case of double mesh with the reverse idler shaft, the 2nd mesh is achieved by means of the gear which is mounted on the reverse idler shaft).

The change gears (movable gears) of the output shafts which are involved in a double mesh have different diameters and thus also a different number of teeth to match the gear step.

The change gears (movable gears) of the 1st output shaft have a larger diameter than those of the 2nd output shaft.

The 02M gearbox has 3 double meshes:

- 1st speed change gear on 1st output shaft and gear of reverse idler shaft with the splines of the input shaft (red),
- 4th speed change gear on the 1st output shaft and 6th speed change gear on the 2nd output shaft with the splines of the input shaft (blue), and
- the splines of the 1st and 2nd output shafts with the final drive gear (green).

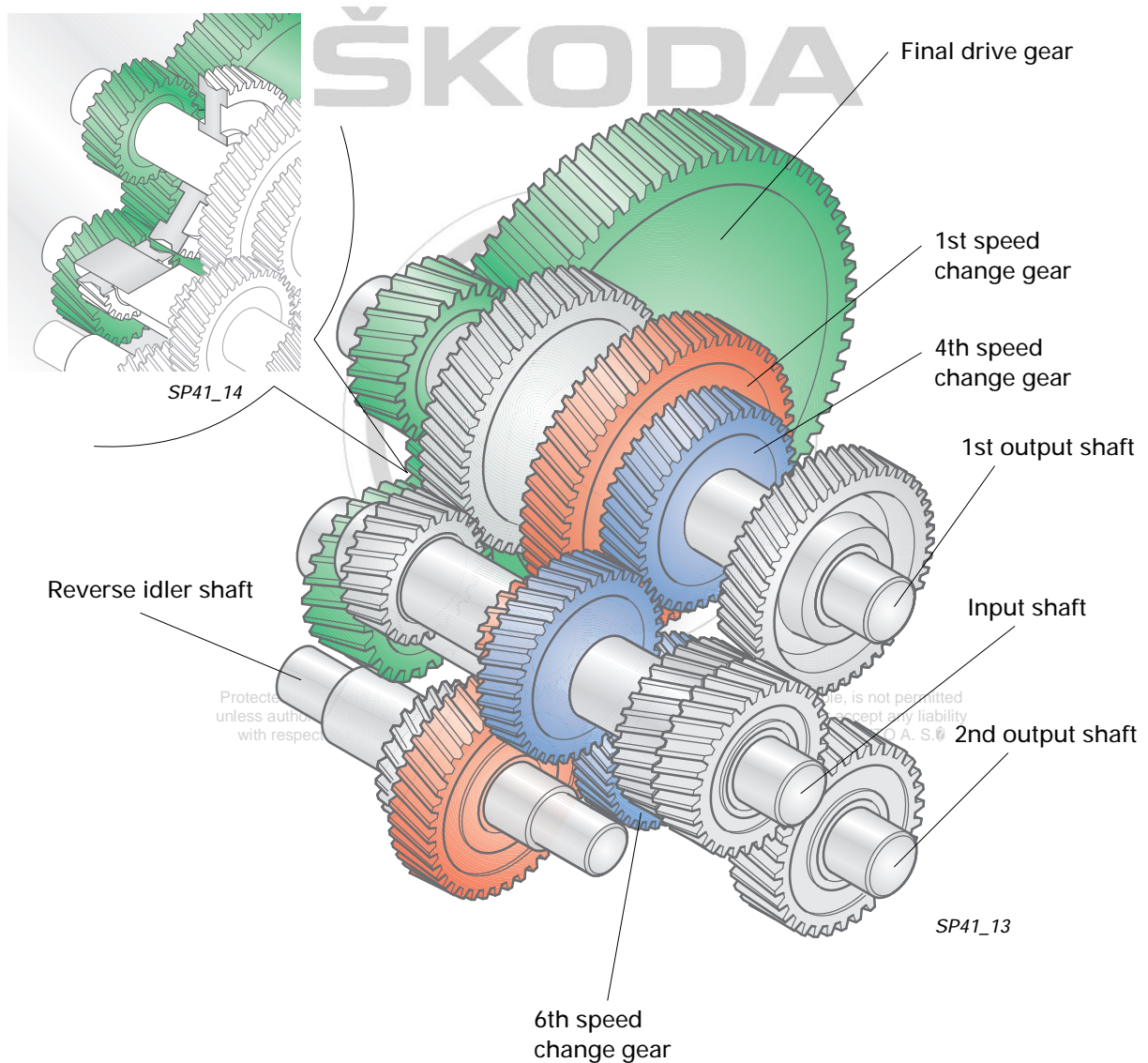

Gearbox Mechanical Components

Clutch control

New!

The clutch control is a hydraulic version.

The slave cylinder and the release bearing form a single unit which is bolted to the clutch housing.

Clutch release lever and separate release bearing with neck bearing are no longer required.

The hydraulic system of the clutch operates with brake fluid and is connected to the brake fluid reservoir.

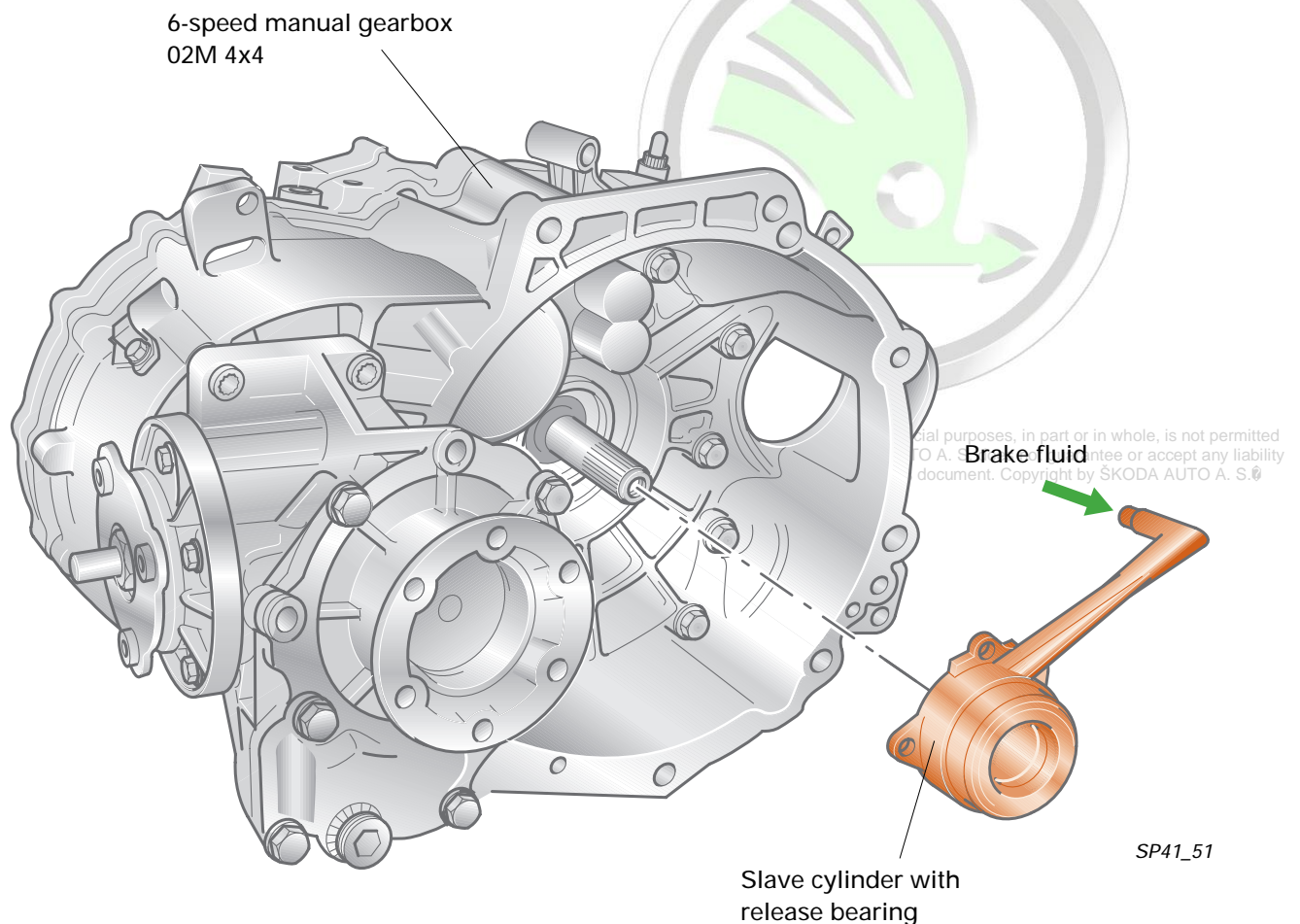

Note:
Slave cylinder and release bearing form a single unit and can only be replaced together.

Slave cylinder and release bearing

The slave cylinder and guide sleeve are firmly connected to each other. The piston of the release bearing moves in an axial direction in the slave cylinder and on the guide sleeve. Two seals positioned one behind the other and which are positively connected to the piston, seal off the release bearing to the slave cylinder and to the guide sleeve.

Balls enclosed in a cage and which in turn support the outer race, run on the inner race of the release bearing which is firmly connected to the piston.

As a result of the spring action of the compression spring the outer race is constantly pressed against the diaphragm spring of the clutch and also rotates with it. A sleeve positively connected to the inner race, protects the release bearing.

The slave cylinder is supplied with brake fluid through a special feed. When the clutch pedal is operated, pressure is produced by the familiar master cylinder at the clutch pedal. The pressurized brake fluid which flows in, pushes the release bearing axially out of the slave cylinder in the direction of the clutch, and the clutch is operated.

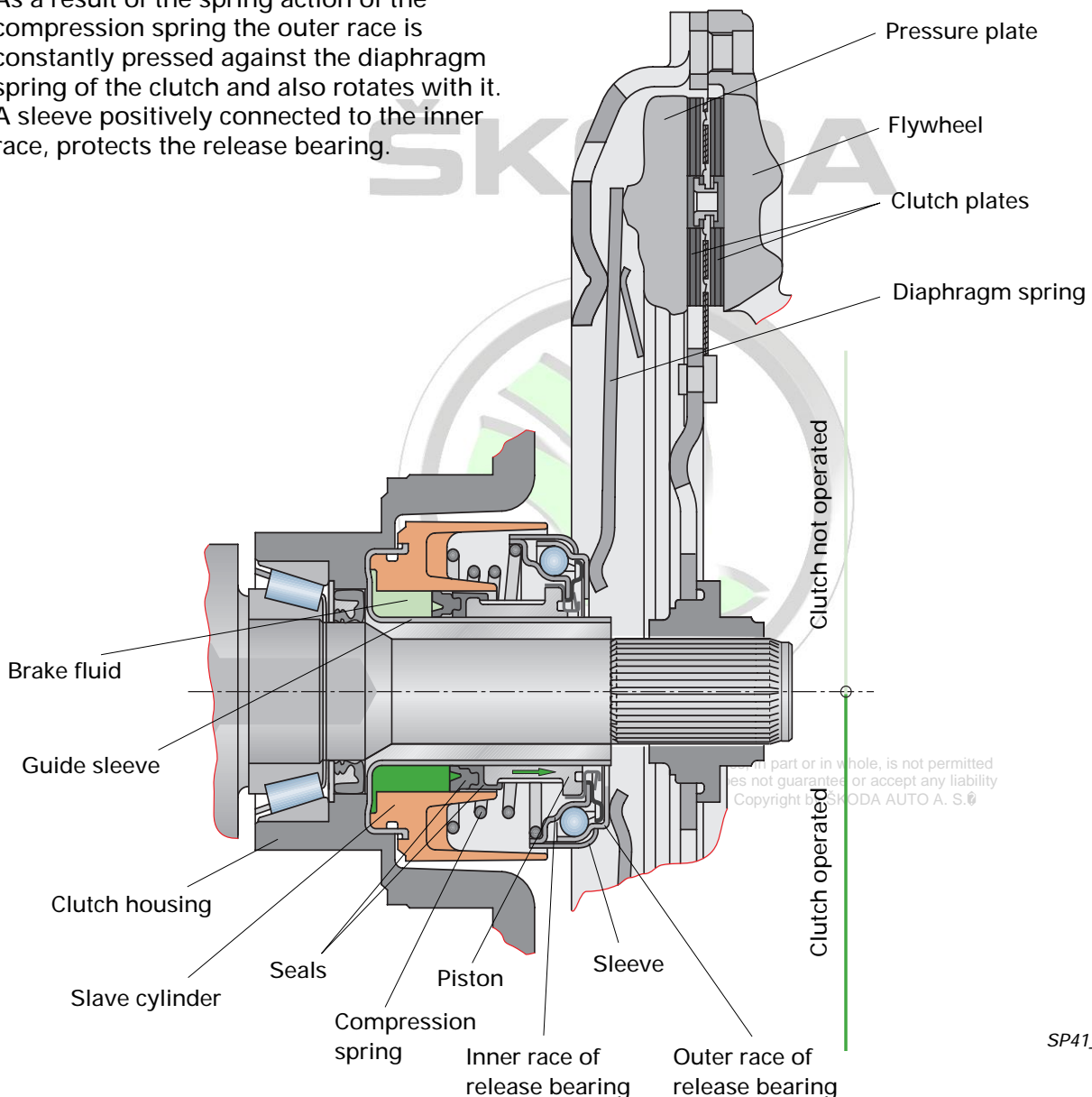

in part or in whole, is not permitted
 es not guaranteed or accept any liability
 Copyright by SKODA AUTO A. S. ©

SP41_52

Gearbox Mechanical Components

Power flow

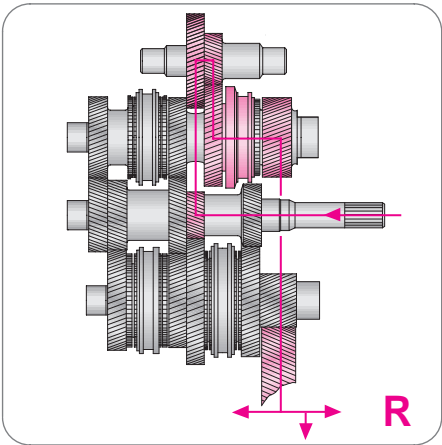

SP41_19

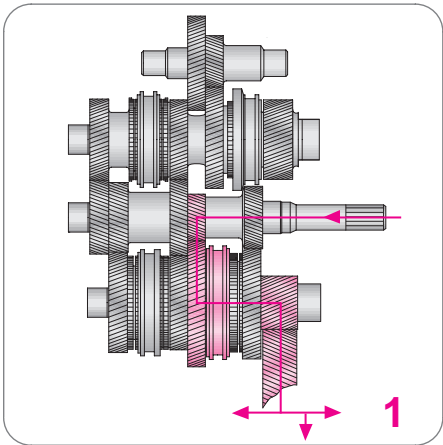

SP41_20

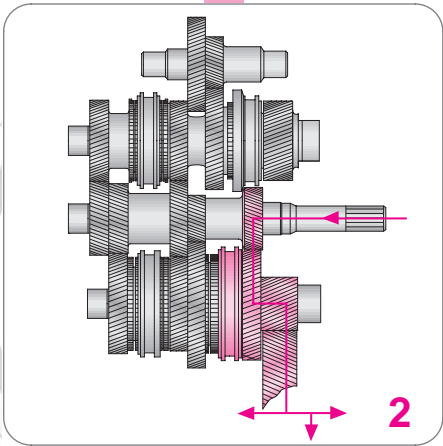

SP41_21

ŠKODA

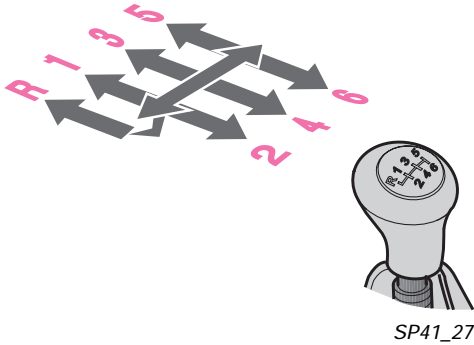

SP41_27

Protected by copyright. Copying for private or commercial purposes, in part or in whole, is not permitted unless authorised by ŠKODA AUTO A. S. ŠKODA AUTO A. S. does not guarantee or accept any liability with respect to the correctness of information in this document. Copyright by ŠKODA AUTO A. S. ©

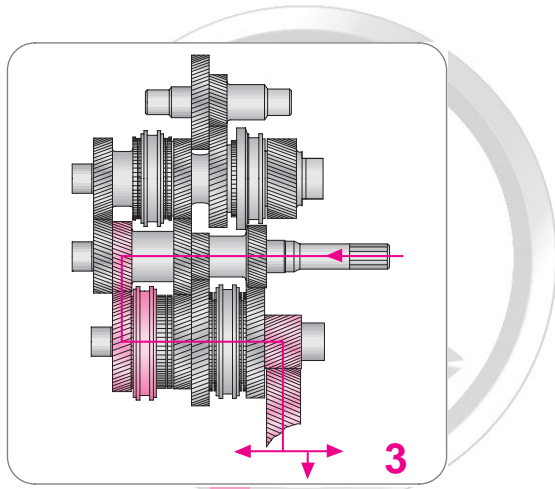

SP41_22

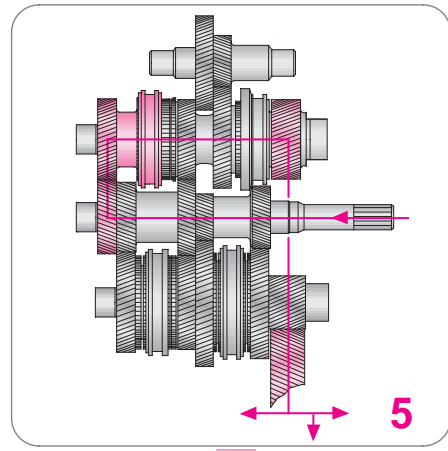

SP41_24

Protected by copyright. Copying for private or commercial purposes, in part or in whole, is not permitted unless authorised by ŠKODA AUTO A.S. ŠKODA AUTO A.S. does not guarantee or accept any liability with respect to the correctness of information in this document. Copyright by ŠKODA AUTO A.S. ©

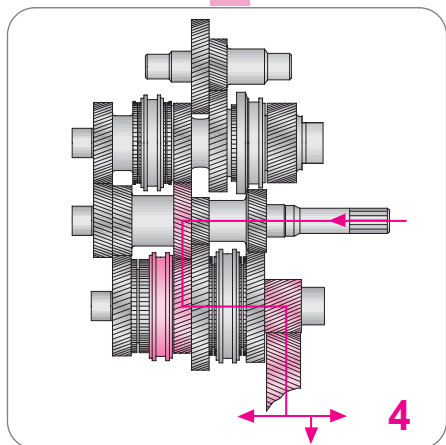

SP41_23

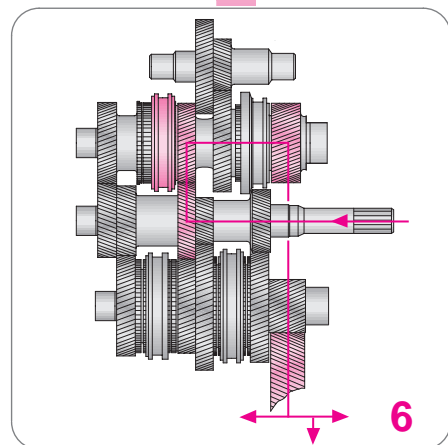

SP41_25

Power flow in the gearbox

The engine torque is passed through the input shaft into the gearbox.

Depending on the gear engaged, the torque is guided by the relevant pair of gears to the 1st or 2nd output shaft and by the latter to the final drive gear.

When reverse gear is engaged, this is achieved additionally through the reverse idler shaft.

Torque and engine speed are now active at the driven wheels in line with the gear engaged.

Shift Mechanism

External shift mechanism

The gearbox features a cable shift in order to eliminate the transmission of vibrations and twisting from the engine area.

Two cables form the link between the gearshift lever inside the car and the gearbox.

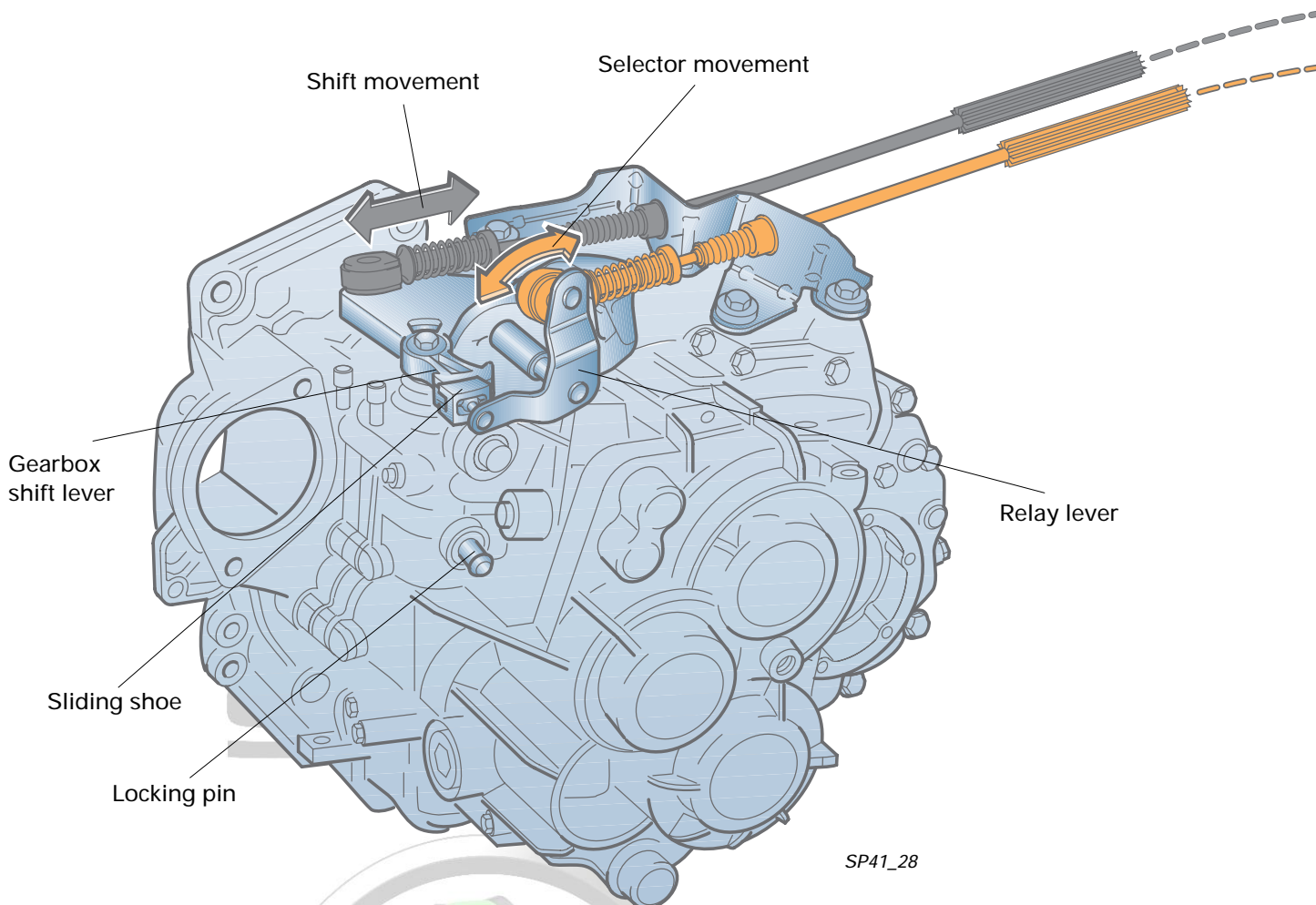

The two cables transmit the selector and shift movement of the gearshift lever to the shift shaft.

The mechanism (relay lever and gearbox shift lever with balancing weight) converts the forward and back movements of the 2 cables into up and down as well as rotational movements of the shift shaft.

The shift shaft can be fixed in a predefined position by means of a locking pin for setting the shift mechanism.

This greatly simplifies the task of setting the mechanism.

A 4-gate shift has been selected for the gearbox in which reverse gear is positioned at the front left in the shift pattern.

The position of the other gears is the same as on the familiar standard shift.

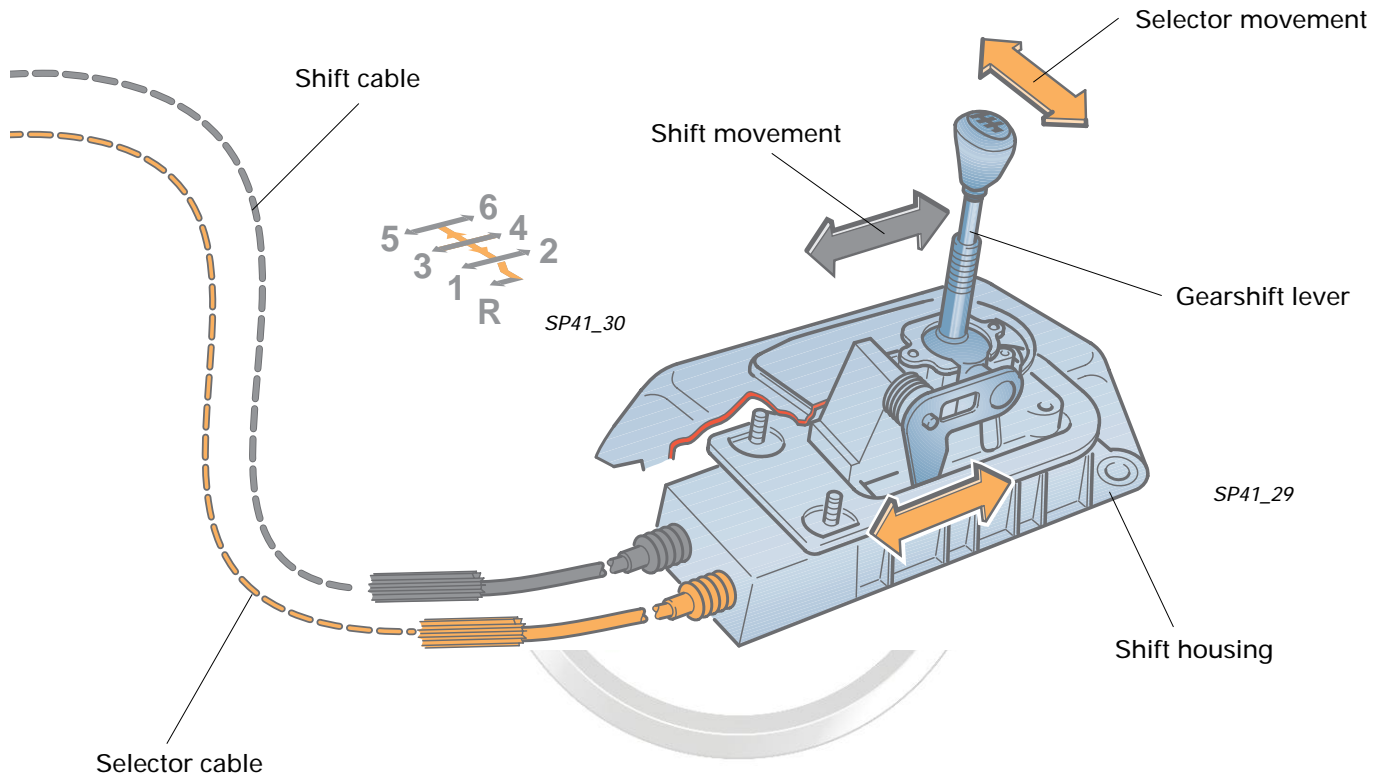

Protected by copyright. Copying for private or commercial purposes, in part or in whole, is not permitted unless authorised by ŠKODA AUTO A. S. ŠKODA AUTO A. S. does not guarantee or accept any liability with respect to the correctness of information in this document. Copyright by ŠKODA AUTO A. S. ©

The familiar depress pressure lock is used as a safeguard against reverse gear being inadvertently engaged (page 29).



Note:
You can find detailed information regarding the setting of the cable shift in the Workshop Manual.

Shift Mechanism

Internal shift mechanism

The shift movements are transmitted through the shift shaft into the gearbox.

The shift shaft is guided in the shift cover and in a mounting inside the gearbox. The internal mounting is attached to the gearbox housing by an end cover.

Both ends of the shift rods with the shift forks for gears 1 to 6 run in a bearing bush both in the clutch housing as well as the gearbox housing.

Spherical sleeves are used for mounting the shift rod ends.

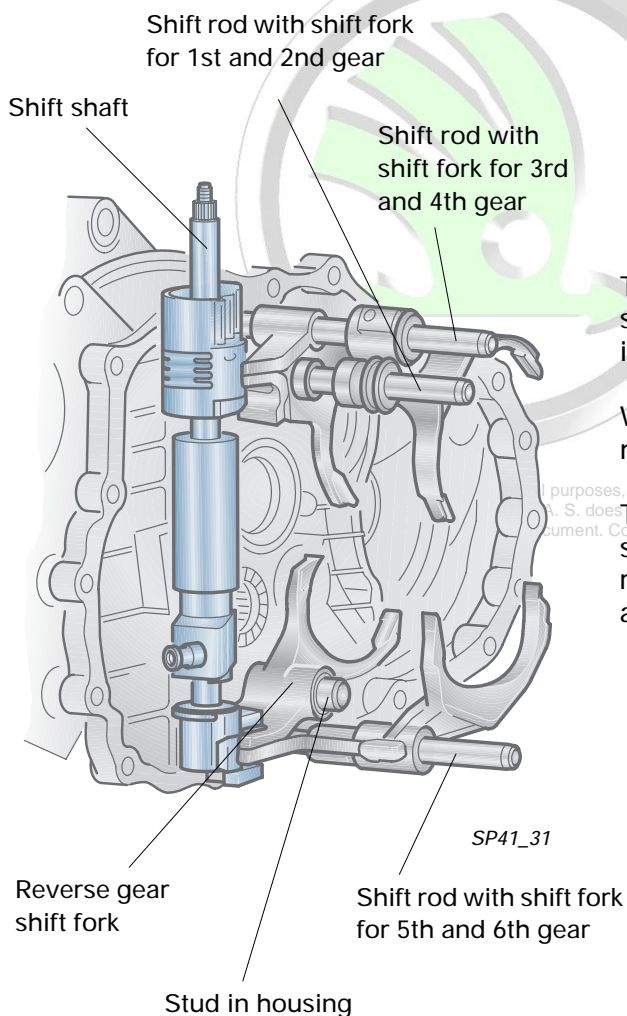
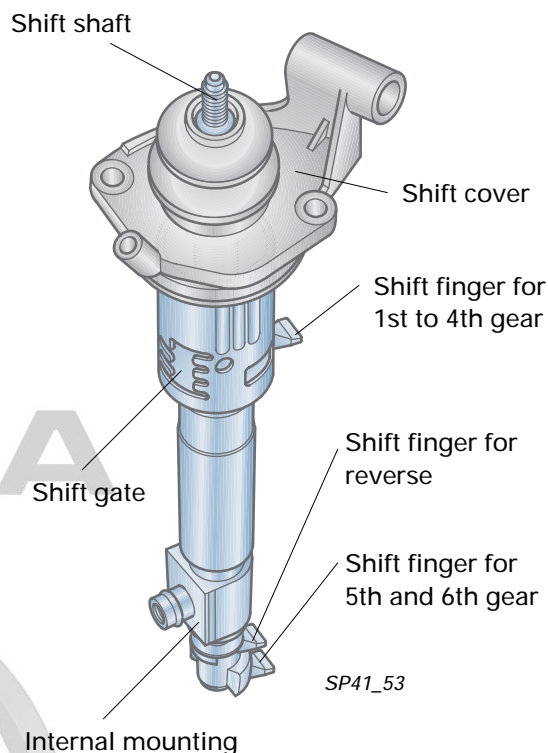

The shift fork for reverse gear is mounted in spherical sleeves on a stud which is attached in the clutch housing.

When a gear is shifted, the shift forks are moved by one each of the two shift fingers.

The shift forks are moved complete with the shift rods in the axial direction of the shift rods, the shift fork for reverse gear is moved axially on the stud in the clutch housing.

The selector movement

The selector movement which is initiated at the gearshift lever (gearshift lever moved to right or left) is transmitted through the selector lever to the selector cable and converted into a forward and back movement.

The selector angle plate is pivot-mounted on a bearing pin.

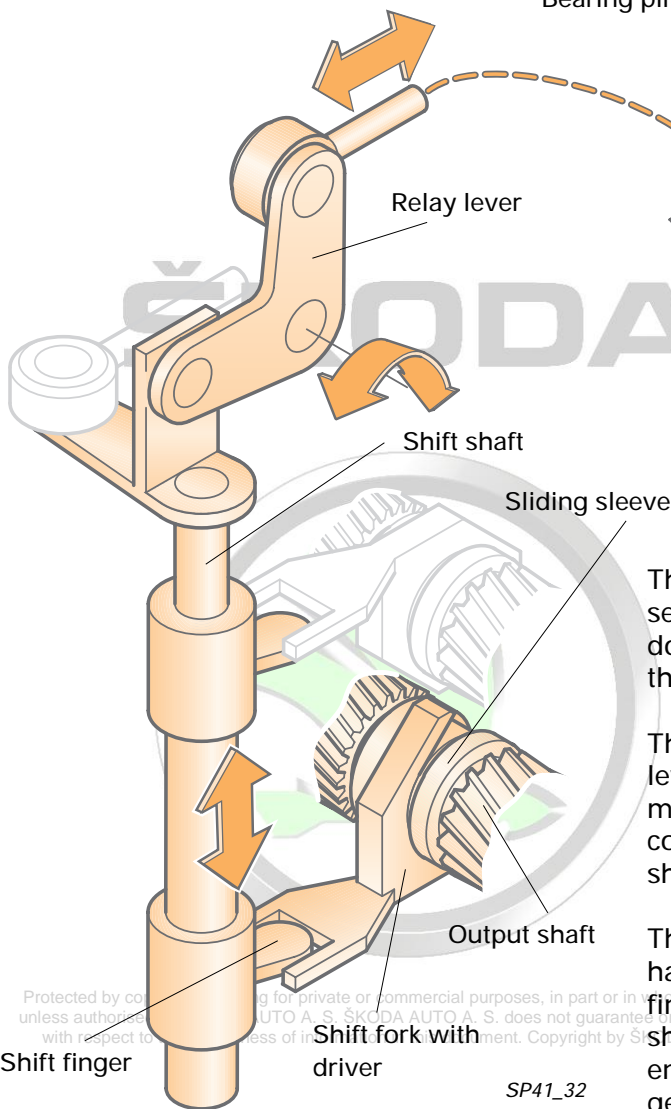
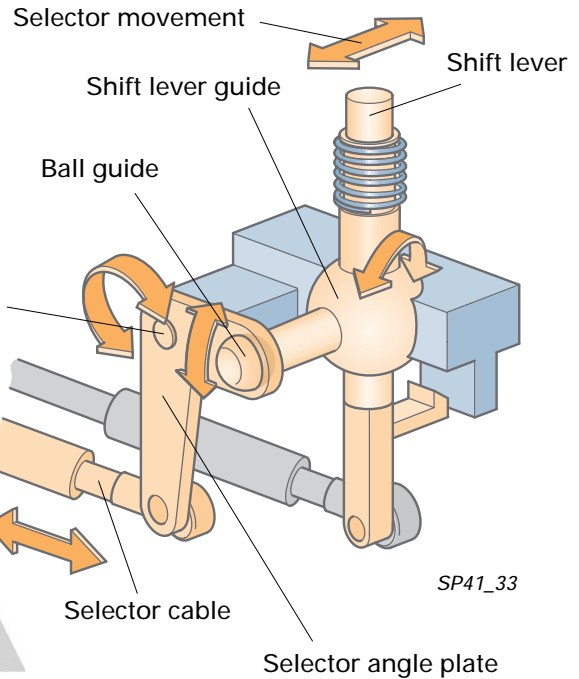
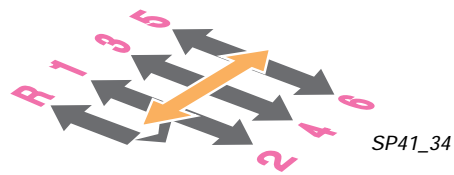

The forward and back movement of the selector cable is converted into an up and down movement of the shift shaft by means of the relay lever mounted at the gearbox.

The selector cable is attached to the relay lever for this purpose. The relay lever is pivot-mounted at the gearbox and flexibly connected by means of a sliding shoe to the shift shaft.

The effect which this up and down movement has in the gearbox is that the relevant shift finger is guided into the driver of the particular shift fork of the selected gear which is to be engaged (1st/2nd gear; 3rd/4th gear; 5th/6th gear or reverse).

Protected by copyright for private or commercial purposes, in part or in whole, without the written permission of SKODA AUTO A. S. SKODA AUTO A. S. does not guarantee the accuracy of information. Copyright by SKODA AUTO A. S.

Shift Mechanism

The shift movement

The shift lever movement is transmitted through the shift lever guide (forward and back movement of the shift lever) to the shift cable.

If the shift lever is moved forward or back in the direction of the individual gears, the shift cable is pulled or pushed in the opposite direction of the movement of the shift lever.

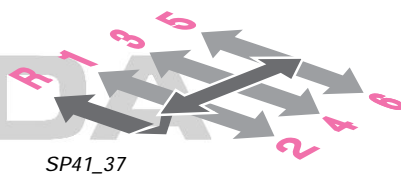

SP41_37

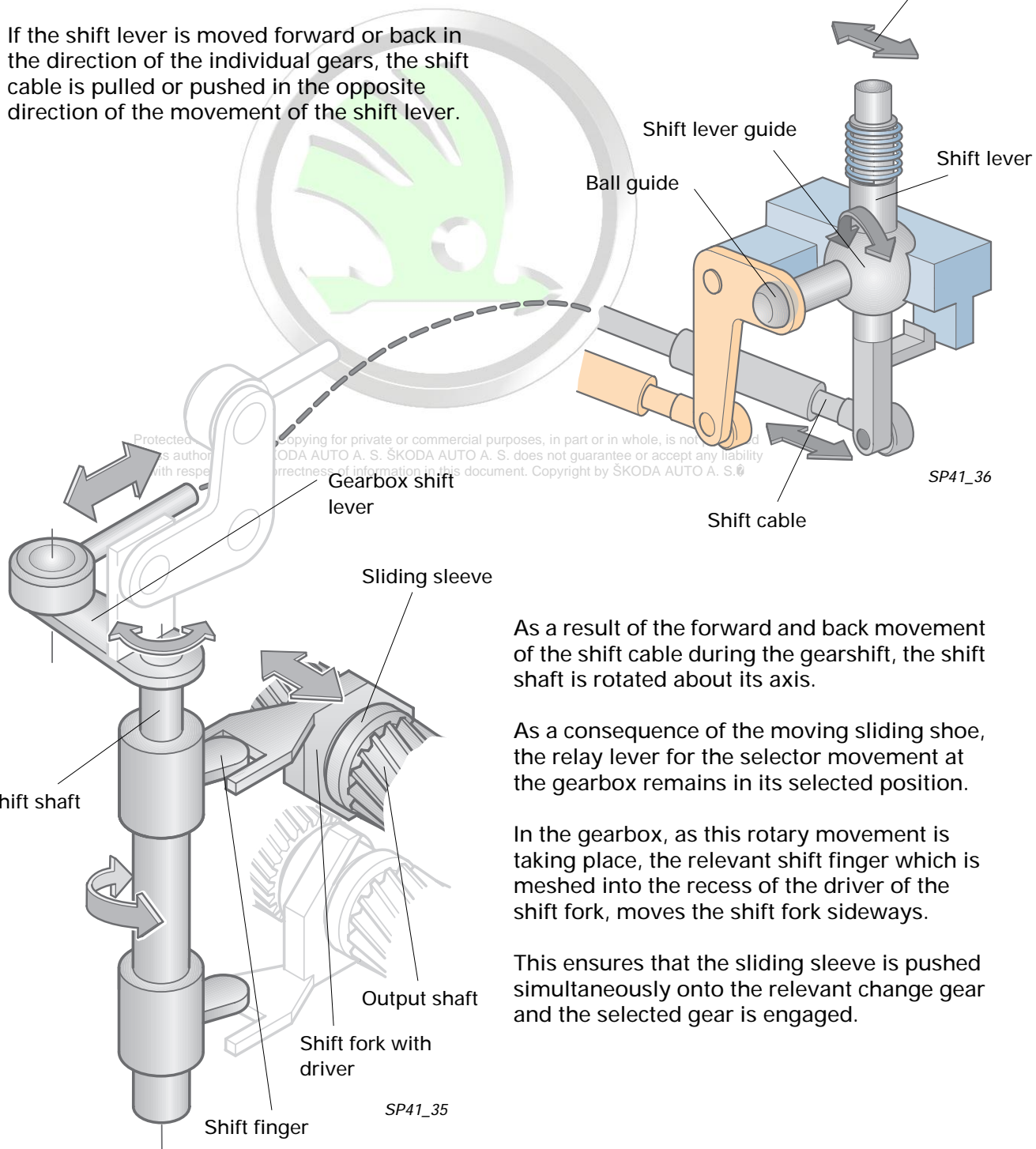

SP41_36

SP41_35

As a result of the forward and back movement of the shift cable during the gearshift, the shift shaft is rotated about its axis.

As a consequence of the moving sliding shoe, the relay lever for the selector movement at the gearbox remains in its selected position.

In the gearbox, as this rotary movement is taking place, the relevant shift finger which is meshed into the recess of the driver of the shift fork, moves the shift fork sideways.

This ensures that the sliding sleeve is pushed simultaneously onto the relevant change gear and the selected gear is engaged.

Reverse gear lock

A depress pressure lock acts as a safeguard to prevent reverse gear being inadvertently engaged.

The depress pressure lock is integrated in the shift housing.

It must first of all be overcome by the driver before it is possible to select and engage reverse gear.

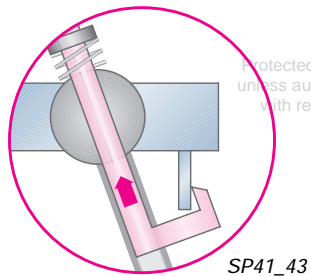
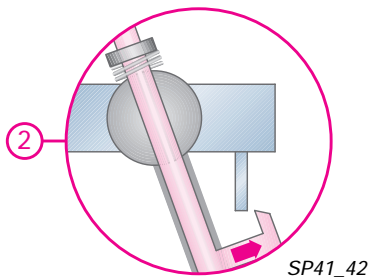
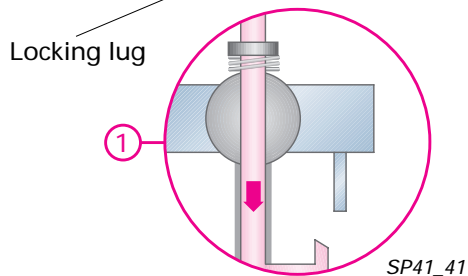
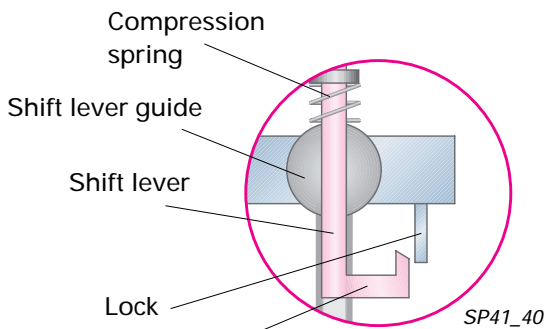
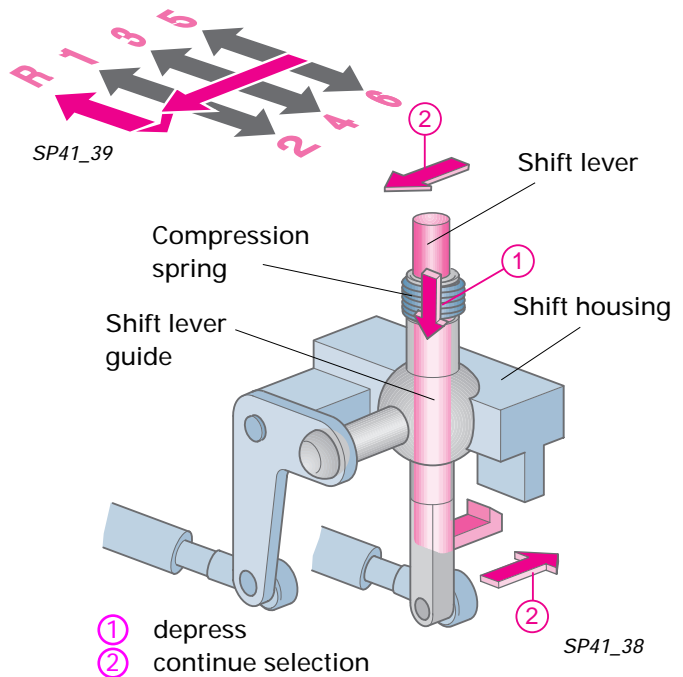

During the normal selection movement of the forward gears, the locking lug of the shift lever strikes against the lock (part of the shift housing).

ŠKODA

When the driver pushes the shift lever down against the compression spring, the lever slides down through the spherical-shaped shift lever guide, the locking lug is now located further down than the lock.

During the subsequent selector movement for reverse gear, the lock is bypassed, it is now possible to engage reverse gear.

Protected by copyright. Copying for private or commercial purposes, in part or in whole, is not permitted unless authorised by ŠKODA AUTO A. S. ŠKODA AUTO A. S. does not guarantee or accept any liability with respect to the content of this document.

When the shift lever is released from the depress movement, the compression spring pushes it back up again into the shifted position and holds it in the reverse gear position.

Sensors

Indication of vehicle speed

Recesses (reference marks) provided on the differential housing generate, in a similar way to a pulse generator gear, the signals required at the speedometer sensor G22 for determining the vehicle speed.

The speedometer sensor G22 is installed from the outside into a hole in the gearbox housing.

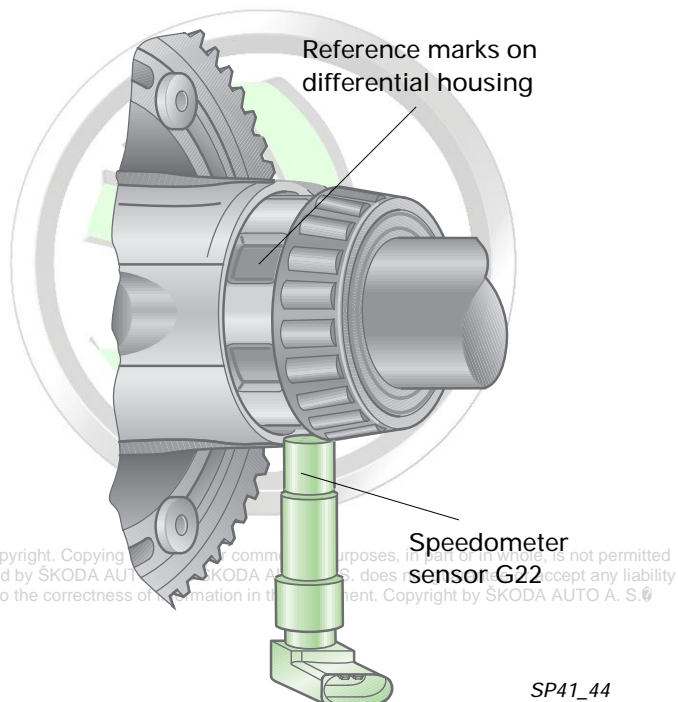

The sensor operates on the Hall principle. The electric pulses of the sensor flow to the control unit in the dash panel insert where they are processed for indicating the vehicle speed and the distance travelled.

This ensures a high level of accuracy for the indications, quiet running and insensitivity to temperature variations.

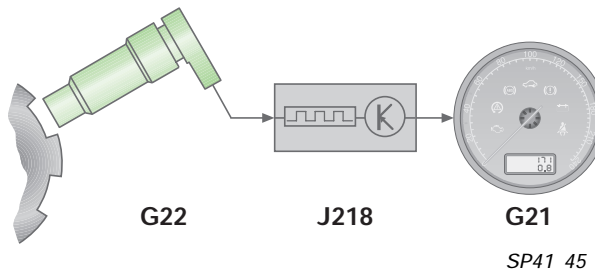

Electric circuit

D +15	Ignition/starter switch, terminal 15
G21	Speedometer
G22	Speedometer sensor
J218	Control unit in dash panel insert

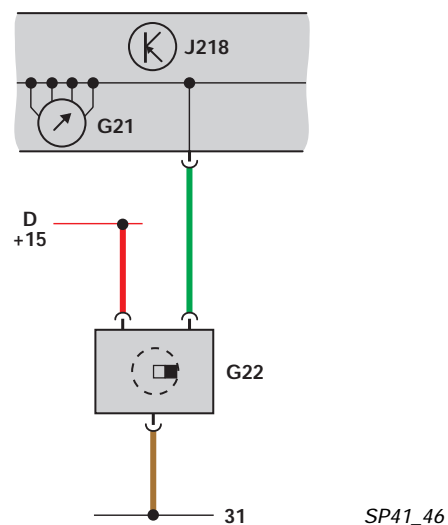

Reversing light switch F4

The switch for the reversing lights is screwed into the side of the gearbox housing.

When reverse gear is selected, the shift gate, together with the shift shaft, is moved sufficiently far into the gearbox so that the pushbutton of the reversing light switch F4 engages in a recess at the lower edge of the shift gate.

During the subsequent gearshift operation, the shift gate pivots about its axis, the pushbutton is moved out of the recess and the switch is operated.

The circuit to the reversing lights is closed.

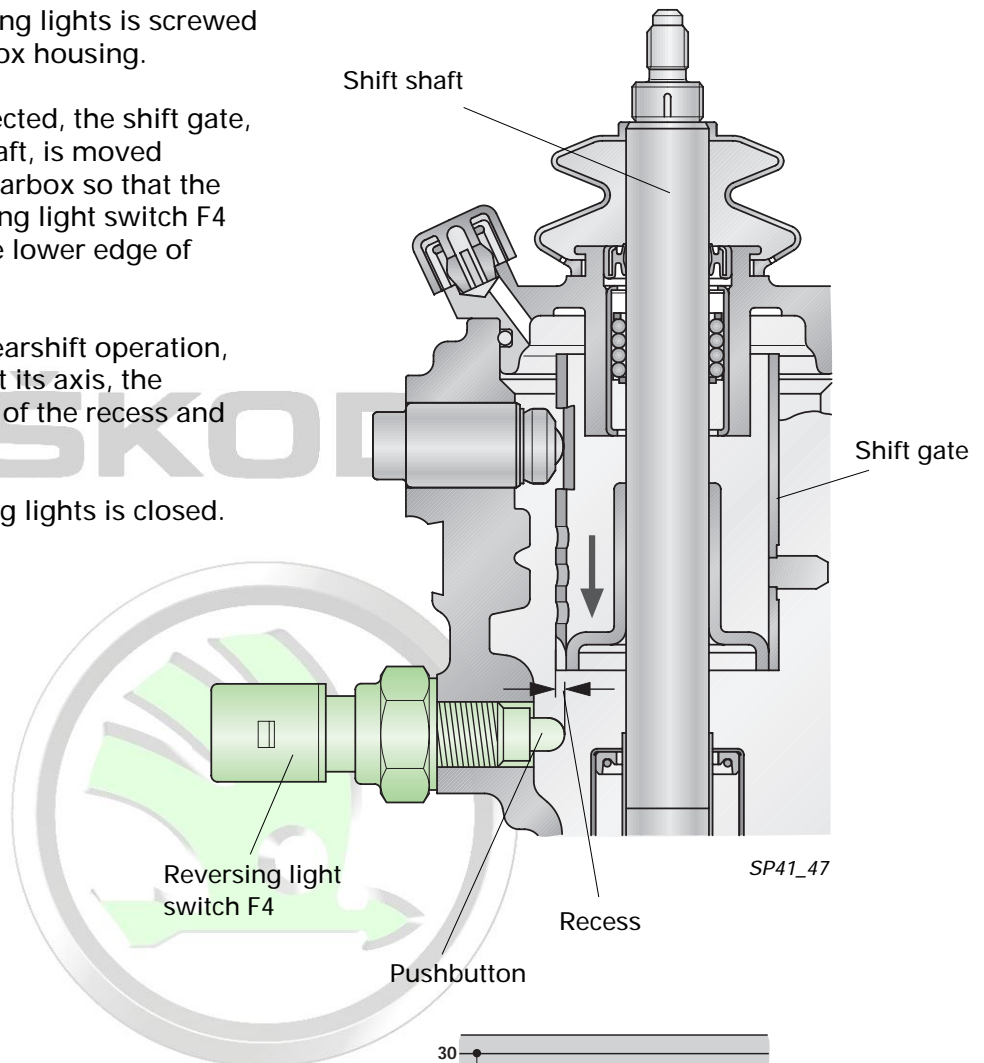

Electric circuit

- D +15 Ignition/starter switch, terminal 15
- F4 Reversing light switch
- M16 Bulb for left reversing light
- M17 Bulb for right reversing light

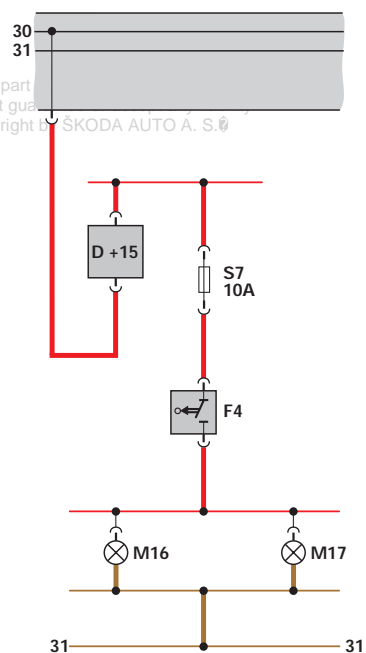

Test Your Knowledge

Which answers are correct?
Sometimes only one.
But perhaps also more than one – or all of them!
Please complete the blank spaces.



1. A 6-speed gearbox offers the advantage of

- A. quieter running.
- B. higher vehicle speed.
- C. improved environmental compatibility.

2. Why was the 02M gearbox for 4x4 designed with two output shafts?

.....
.....
.....

3. How are the gears assigned to the 1st and 2nd output shafts?

1st output shaft
2nd output shaft

4. Draw in the power flow for 6th gear.

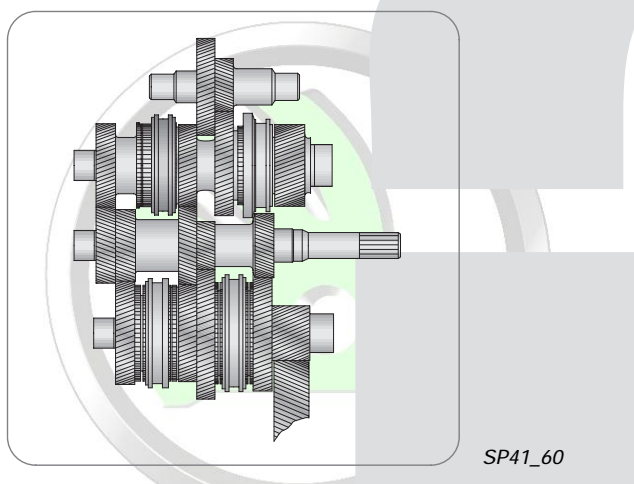

Protected by copyright. Copying for private or commercial purposes, in part or in whole, is not permitted unless authorised by ŠKODA AUTO A. S. ŠKODA AUTO A. S. does not guarantee or accept any liability with respect to the correctness of information in this document. Copyright by ŠKODA AUTO A. S. ©

5. What is a "double mesh"?

.....
.....
.....

6. The gearbox has

- A. one double mesh.
- B. two double meshes.
- C. three double meshes.

7. Hollow-boring of the gearbox shafts is designed to

- A. enhance the torsional stiffness.
- B. ensure quiet gearbox running.
- C. reduce the weight of the gearbox.

8. The bevel box for additionally transmitting the torque to the rear axle

- A. is a stand-alone unit and positioned downstream of the differential.
- B. is part of the differential.
- C. forms a single unit together with the differential and the gearbox.

9. The clutch control is performed

- A. hydraulically by means of a clutch release lever and a separate release bearing with neck bearing.
- B. by means of a hydraulic unit, consisting of slave cylinder and release bearing.
- C. mechanically by means of a clutch release lever which moves the release bearing mounted on the input shaft axially.

for private or commercial purposes, in part or in whole, is not permitted
is a information in this document. Copyright by SKODA AUTO A.S. ®

Test Your Knowledge

ŠKODA

5. In the case of a double mesh the single set of splines of the input shaft is meshed both with a change gear (movable gear) of the 1st output shaft as well as with a change gear of the 2nd output shaft. In this case, though, there is always only one gear shifted (on the respective output shaft).
6. C.
7. C.
8. C.
9. B.

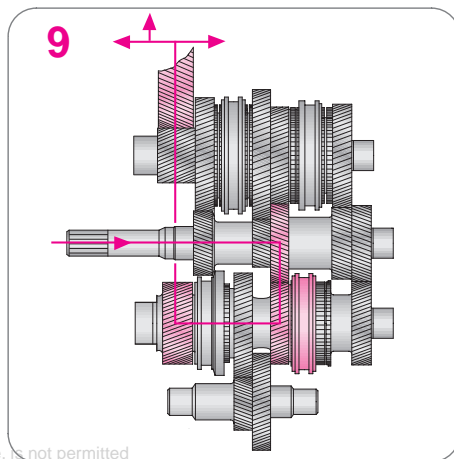

Protected by copyright. Copying for private or commercial purposes, in part or in whole, is not permitted unless authorised by ŠKODA AUTO A. S. ŠKODA AUTO A. S. does not guarantee or accept any liability with respect to the correctness of information in this document. Copyright by ŠKODA AUTO A. S. ©

1. A; C.
2. Because using two short output shafts in comparison to a single long output shaft makes it possible to achieve a shorter overall length.
3. 1st output shaft: 1st - 4th gear
4. 2nd output shaft: 5th/6th and reverse gear

Answers:

ŠKODA



Protected by copyright. Copying for private or commercial purposes, in part or in whole, is not permitted unless authorised by ŠKODA AUTO A. S. ŠKODA AUTO A. S. does not guarantee or accept any liability with respect to the correctness of information in this document. Copyright by ŠKODA AUTO A. S. ®