

**ŠKODA**

Engines
1.8 | TFSI 132 kW,
2.0 | TFSI 162 kW

EA888 design range

Protected by copyright. Copying for private or commercial purposes, in part or in whole, is not permitted unless authorised by ŠKODA AUTO A. S. ŠKODA AUTO A. S. does not guarantee or accept any liability with respect to the correctness of information in this document. Copyright by ŠKODA AUTO A. S. ©

Self-study Programme

ŠKODA



Protected by copyright. Copying for private or commercial purposes, in part or in whole, is not permitted unless authorised by ŠKODA AUTO A. S. ŠKODA AUTO A. S. does not guarantee or accept any liability with respect to the correctness of information in this document. Copyright by ŠKODA AUTO A. S. ©

Contents

Engines 1.8 | TFSI, 2.0 | TFSI (EA888 design range)

1. Introduction of the 1.8 TFSI / 132 kW Engine	5
1.1 Engine Characteristics	5
1.2 Table of Engine Parameters	6
1.3 Engine Power Chart	7
2. Development Objectives of the New Engine Design	8
2.1 Aggregate Modularity	8
2.2 EU6 Standard Compliant – Reduced Emissions of Solid Particles and CO ₂	8
2.3 Lower Fuel Consumption	8
3. Engine Weight Reduction	9
3.1 Engine Weight Reduction Measures	9
4. Cylinder Block and Oil Sump	10
4.1 Cylinder Block	10
4.2 Oil Sump	10
4.3 Cylinder Block and Oil Sump – Configuration	11
5. Cylinder Head	12
5.1 Cylinder Head – Configuration	13
5.2 Integrated Exhaust Gas Ducts	15
5.3 Integrated Exhaust Gas Ducts Cooling	16
6. Crank Mechanism	17
6.1 Piston	18
6.2 Connecting Rods	18
6.3 Crankshaft	18
6.4 Crankshaft Mounting	19
7. Chain Timing Mechanism of the 1.8 TFSI engine	20
7.1 Balancing Shafts of the Chain Timing Mechanism	21
8. Fuel Injection	22
8.1 The Basic Fuel Injection Principles and the Combined Injection Rationale	22
8.2 Combined Fuel Injection System Design	23
8.2.1 The FSI High-Pressure Fuel Injection System	24
8.2.2 The MPI Low-Pressure Fuel Injection System	24
8.3 Injection Modes in Dependence on Engine Load Type	25
8.4 Fuel System Diagram	26
9. Cooling System	27
9.1 Coolant Pump and Engine Temperature Regulation Controller	27
9.2 Engine Temperature Regulation Controller	28
9.3 Engine Temperature Regulation Controller Modes	30
10. Air Intake System with a Turbocharger	33
10.1 System Diagram	33
10.2 Intake Manifold Design	35
10.3 Turbocharger	37
11. Crankcase Ventilation	39
11.1 Crankcase Ventilation Principle	39
11.2 Basic Description of the Crankcase Ventilation System	40
11.3 Coarse Oil Separation	41
11.4 Fine Oil Separation	41
11.5 Supply of Cleaned Gases to the Combustion Chamber	42

12. Engine Lubrication	44
12.1 Lubrication System Changes	44
12.2 Holder of Auxiliary Aggregates with Oil Filter and Engine Oil Cooler	44
12.3 Engine Lubrication System	46
12.4 Two-Stage Regulation Oil Pump	47
12.5 Oil Circuit Diagram	48
12.6 Piston Cooling Nozzles	50
12.6.1 Operating Mode with Disconnected Cooling Nozzles	50
12.6.2 Operating Mode with Active Cooling Nozzles	51
12.6.3 Piston Cooling Nozzles Operating Modes Chart	52
12.6.4 Piston Cooling Nozzle System Monitoring Function	52
13. 2.0 I TFSI 162 kW Engine	53
13.1 Engine Characteristics	53
13.2 Comparison of the 2.0 I TFSI 162 kW and 1.8 TFSI 132 kW Engines	53
13.3 Table of Engine Parameters	56
13.4 Engine Power Chart	57

ŠKODA

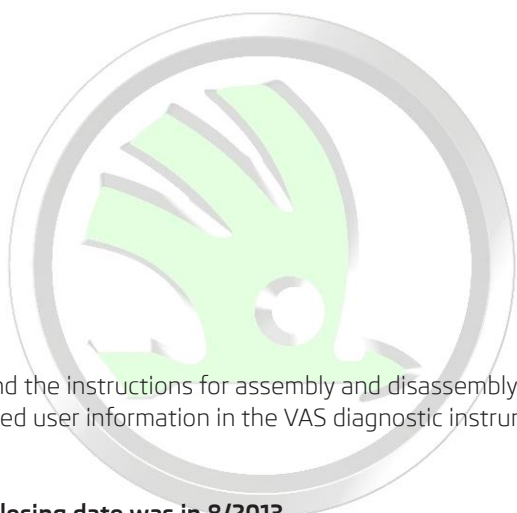

You will find the instructions for assembly and disassembly, repairs, for diagnostics plus detailed user information in the VAS diagnostic instruments and in the on-board literature.

Editorial closing date was in 8/2013.

This Book is not subject to updating.

Protected by copyright. Copying for private or commercial purposes, in part or in whole, is not permitted unless authorised by ŠKODA AUTO A. S. ŠKODA AUTO A. S. does not guarantee or accept any liability with respect to the correctness of information in this document. Copyright by ŠKODA AUTO A. S. ©



SP95_00

1. Introduction of the 1.8 TFSI / 132 kW Engine

1.1 Engine Characteristics

New engine's main characteristics:

- cylinder head structure with an integrated exhaust pipe (turboblower weight reduction by 40 %)
- combined direct (FSI) and indirect (MPI) injection (to limit formation of solid particulate)
- two injectors per cylinder
- variable timing of the intake and exhaust valves with a chain control gear
- variable lift of exhaust valves
- Intelligent cooling circuit - temperature control based on the engine load and RPM
- One Lambda probe upstream of turboblower and another Lambda probe downstream catalytic converter
- increase of injection pressure (FSI) to 200 bar
- reduction of weight
- turboblower controlled by an electric motor

ŠKODA



Protected by copyright. Copying for private or commercial purposes, in part or in whole, is not permitted unless authorised by ŠKODA AUTO A. S. ŠKODA AUTO A. S. does not guarantee or accept any liability with respect to the correctness of information in this document. Copyright by ŠKODA AUTO A. S. ©

1.2 Table of Engine Parameters

Engine Parameters	
Design	Ignition inline four-cylinder petrol engine, two top-mounted camshafts (2xOHC) with chain drive, turbocharged engine with intercooler, with combined fuel injection, mounted transversally at the front, Liquid-cooled aggregate
Number of cylinders	4
Displacement	1798 cm ³
Bore	82.5 mm
Stroke	84.2 mm
Max. power	132 kW at 5100–6200 ⁻¹
Max. torque	250 Nm* at 1250–5000 ⁻¹
Compression ratio	9.6 : 1
Charging	electronically controlled combined fuel injection
Intake valve control	Continuous intake camshaft adjustment
Exhaust valve control	Continuous exhaust camshaft adjustment, The AVS system – of two-stage exhaust valve lift switching
Ignition	electronic ignition
Lubrication	of pressure circulating type with a full-flow oil filter
Fuel	unleaded gasoline of min. oct. no. 95/91**
Emission standard	EU6
Engine weight	134 kg

* 280 Nm in connection with the 4x4 drive

** When using gasoline of lower octane index, the power may be reduced slightly.

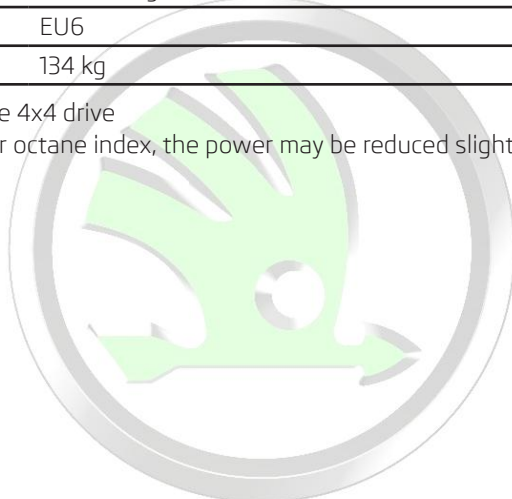

Protected by copyright. Copying for private or commercial purposes, in part or in whole, is not permitted unless authorised by ŠKODA AUTO A. S. ŠKODA AUTO A. S. does not guarantee or accept any liability with respect to the correctness of information in this document. Copyright by ŠKODA AUTO A. S. ©

1.3 Engine Power Chart

The engine features the maximum torque of 250 Nm, which is available thanks to its turbocharger and advanced valve equipment within a wide RPM interval. From 1,250 to 5,000 RPM⁻¹.

The engine version designed for the vehicles with all wheel drive, where rear axle is driven by the Haldex clutch, provides the maximum torque of 280 Nm at 1,350 - 4,500 RPM⁻¹.

It offers the same maximum output of 132 kW at 4,500 - 6,200 RPM⁻¹.

The performance characteristics is further adapted by the engine control unit software.

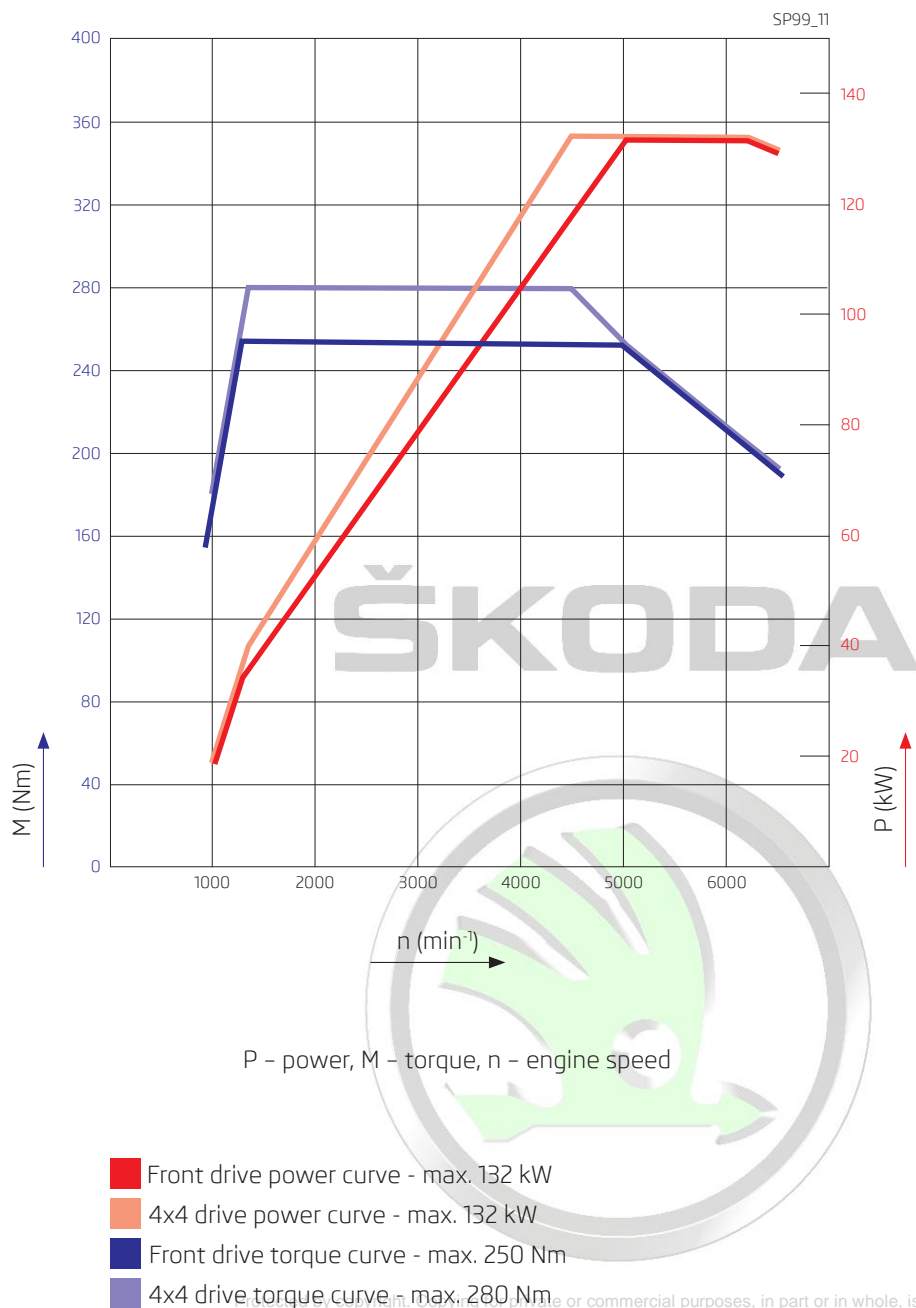

Reproduction, copying, distribution, or commercial purposes, in part or in whole, is not permitted unless authorised by ŠKODA AUTO A. S. ŠKODA AUTO A. S. does not guarantee or accept any liability with respect to the correctness of information in this document. Copyright by ŠKODA AUTO A. S. ©

2. Development Objectives of the New Engine Design

2.1 Aggregate Modularity

The third generation of the 1.8 TFSI, EA888 series engine has been designed in line with the VW group's modular concept strategy. The dimensions, mounting and connecting points of the 3rd generation of the EA888 engine design series have been designed in a way, thanks to which the engine may be used as a "global aggregate" with transverse mounting (MQB*) and longitudinal mounting (MLB**).

The transverse mounting features an engine bearer and oil dipstick. If the engine is mounted longitudinally, engine brackets and a cap instead of the oil dipstick will be used. These mounting options enable installation of this engine series within the whole VW group.

2.2 EU6 Standard Compliant - - Reduced Emissions of Solid Particles and CO₂

The new aggregate has not only been developed because of adoption of the modular strategy by the VW group, which is applied to all vehicle parts, including aggregates.

The aggregate was also developed due to the application of more stringent exhaust gas standards (EU 6 standard), and also to reduce fuel consumption and CO emissions₂.

That is why the engine has been completely redesigned from all perspectives.

The following items were key during the new engine development:

- Engine design, featuring the maximum number of parts identical to all the engine versions
- Engine weight reduction
- Reduced engine internal friction
- Increased engine output and torque at reduced fuel consumption
- Improved aggregate comfort qualities

2.3 Lower Fuel Consumption

Downsizing

The turbocharging of petrol engines resulted in smaller and lighter aggregates, as required.

Downspeeding

During the design of the third generation of the EA888 engines, the requirement was to develop an aggregate with even a greater torque interval in order to shift the engine operation to lower RPM.

The designers responded to this requirement primarily by focusing development efforts on valves:

- a) Variable valve timing
 - Intake camshaft adjuster
 - Exhaust camshaft adjuster development
- b) Exhaust valves two-stage lift switching
- c) Engine timing chain friction optimization

The measures applied in both groups reduce fuel consumption.

Protected by copyright. Copying for private or commercial purposes, in part or in whole, is not permitted unless authorised by ŠKODA AUTO A. S. ŠKODA AUTO A. S. does not guarantee or accept any liability with respect to the correctness of information in this document. Copyright by ŠKODA AUTO A. S. ©

* MQB – Modularer Querbaukasten

** MLB – Modularer Längsbaukasten

3. Engine Weight Reduction

The weight of the new 1.8 TFSI EA888 series 3rd generation engine decreased by 7.8 kg thanks to the weight reduction of the following engine components.

3.1 Engine Weight Reduction Measures

- Thin cylinder block wall
- Absence of external oil separator, the coarse oil separator labyrinth is integrated in the new engine directly in its cylinder block
- Lighter cylinder head with integrated exhaust piping and connected turbocharger
- Lighter crankshaft with its four counterbalances in smaller diameter bearings
- Oil sump upper section of aluminium pressure casting
- Plastic oil sump bottom part
- Aluminium bolts in the whole engine
- Balancing shafts partially supported in needle bearings

Protected by copyright. Copying for private or commercial purposes, in part or in whole, is not permitted unless authorised by ŠKODA AUTO A. S. ŠKODA AUTO A. S. does not guarantee or accept any liability with respect to the correctness of information in this document. Copyright by ŠKODA AUTO A. S. ©

4. Cylinder Block and Oil Sump

4.1 Cylinder Block

Weight has been reduced:

Most weight reduction has been achieved on the cylinder block.

The cylinder block wall thickness has been reduced from 3.5 mm to 3.0 mm.

The coarse oil separator has been integrated into the cylinder block.

As a result, the cylinder block weight decreased, compared to the 2nd generation engine, by a total of 2.4 kg.

Internal friction has been reduced:

The crankshaft primary bearings are of a smaller diameter.

The balancing shafts have been partially supported by means of needle bearings.

Additional changes, compared to the 2nd generation engine:

- Changed cross-section of the coolant return line
- The oil radiator is fed via the cylinder block coolant return line
- Knocking sensor optimized position

Cylinder block sealed using a liquid sealant

The engine side cover is sealed by a liquid sealant. The flange is mounted to the cylinder block by aluminium bolts. Liquid sealant has been applied to the timing mechanism cover as well.

4.2 Oil Sump

Oil sump top section

It is made of an aluminium pressure casting. An oil pump is bolted in it and a honeycomb insert for oil suction and return flow. The oil sump top section also features pressure oil lines and the two-stage oil pump control valve. It is sealed to the cylinder block by a liquid sealant and mounted by aluminium bolts. The main bearings covers are bolted to the oil sump top section in order to further improve the aggregate's acoustic qualities.

Oil sump bottom part

The oil sump bottom part is made of plastic. It has saved about 0.1 kg of weight.

It is sealed by a die-formed rubber gasket and mounted by steel bolts.

The oil sump bottom part features the G266 oil level and temperature sensor.

The oil drainage bolt is also made of plastic (bayonet joint).

Protected by copyright. Copying for private or commercial purposes, in part or in whole, is not permitted unless authorised by ŠKODA AUTO A. S. ŠKODA AUTO A. S. does not guarantee or accept any liability with respect to the correctness of information in this document. Copyright by ŠKODA AUTO A. S. ©

4.3 Cylinder Block and Oil Sump -- Configuration

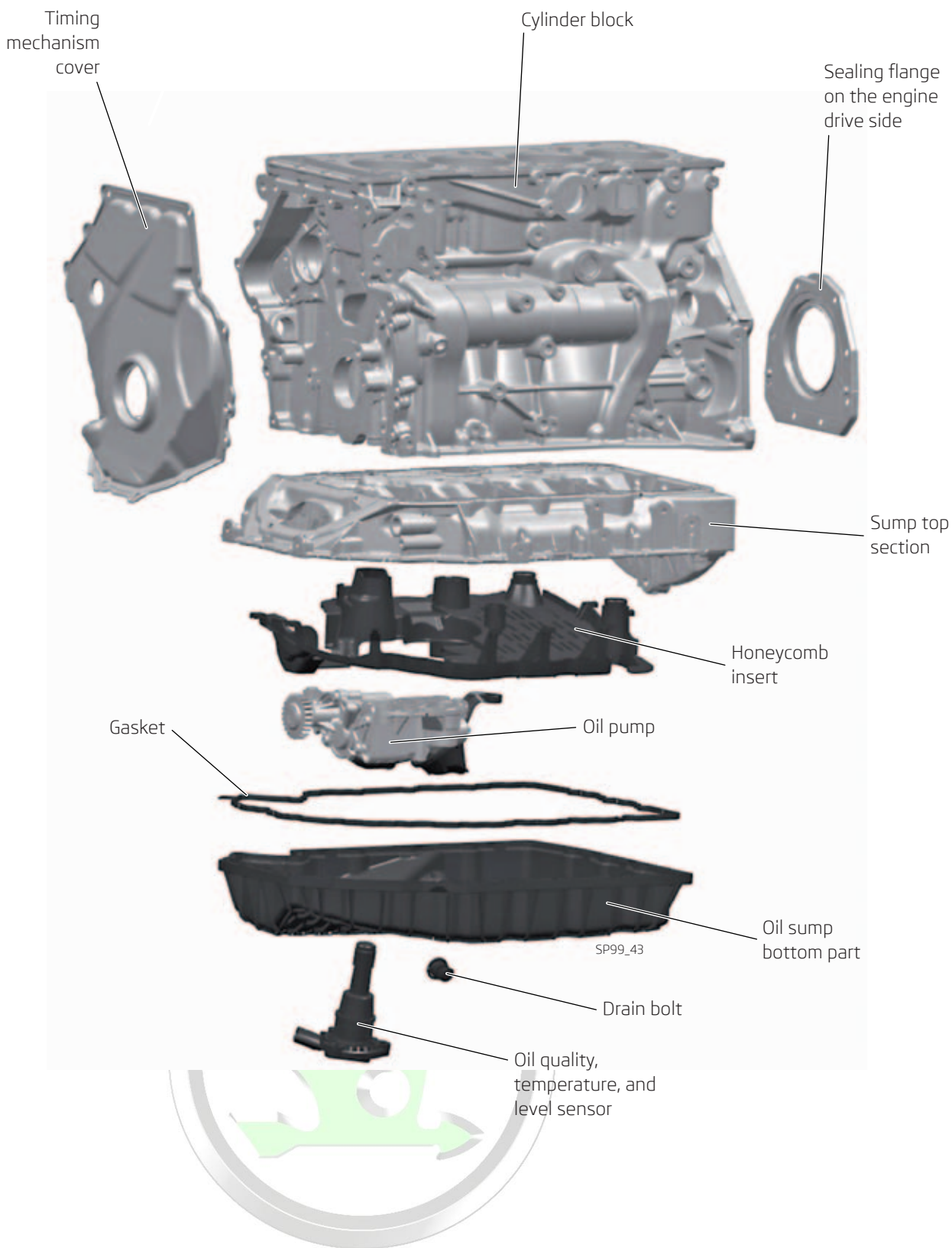

Protected by copyright. Copying for private or commercial purposes, in part or in whole, is not permitted unless authorised by ŠKODA AUTO A. S. ŠKODA AUTO A. S. does not guarantee or accept any liability with respect to the correctness of information in this document. Copyright by ŠKODA AUTO A. S. ©

5. Cylinder Head

The cylinder head has been completely redesigned, compared to the previous engine generation. Among turbocharged engines, this is the first engine, featuring exhaust gas cooling using a special cooling line directly integrated into the cylinder head.

Additional cylinder head design changes:

- Extended spark plug thread
- New ignition modules
- Optimized weight camshafts
- Reduced elasticity of the timing mechanism
- The G62 coolant temperature sensor installed in the cylinder head
- High-pressure pump in a new position
- Turbocharger turbine casing directly attached to the cylinder block
- Optimized intake ducts
- Flexible separation of injection valves from the cylinder head

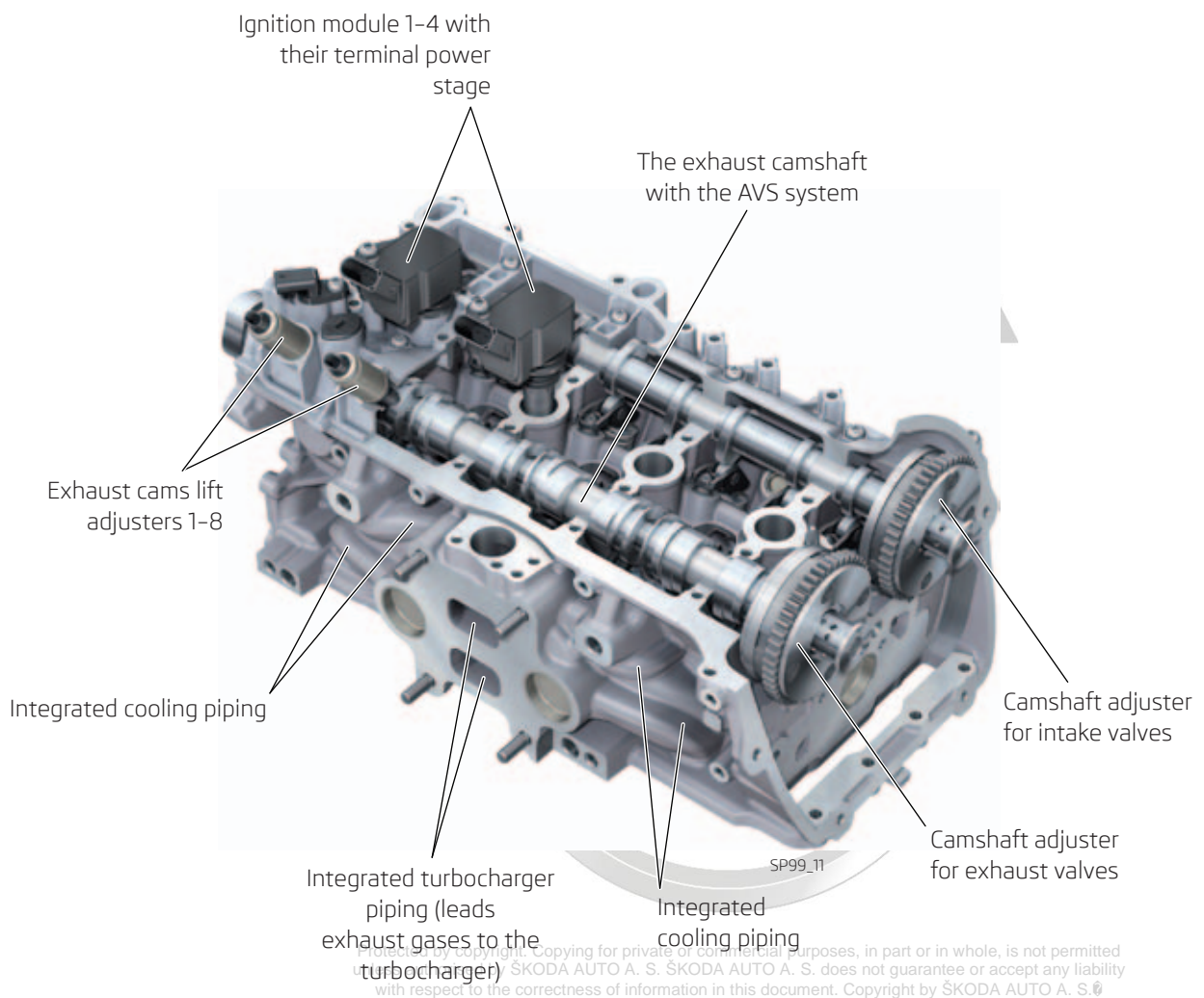

5.1 Cylinder Head -- Configuration

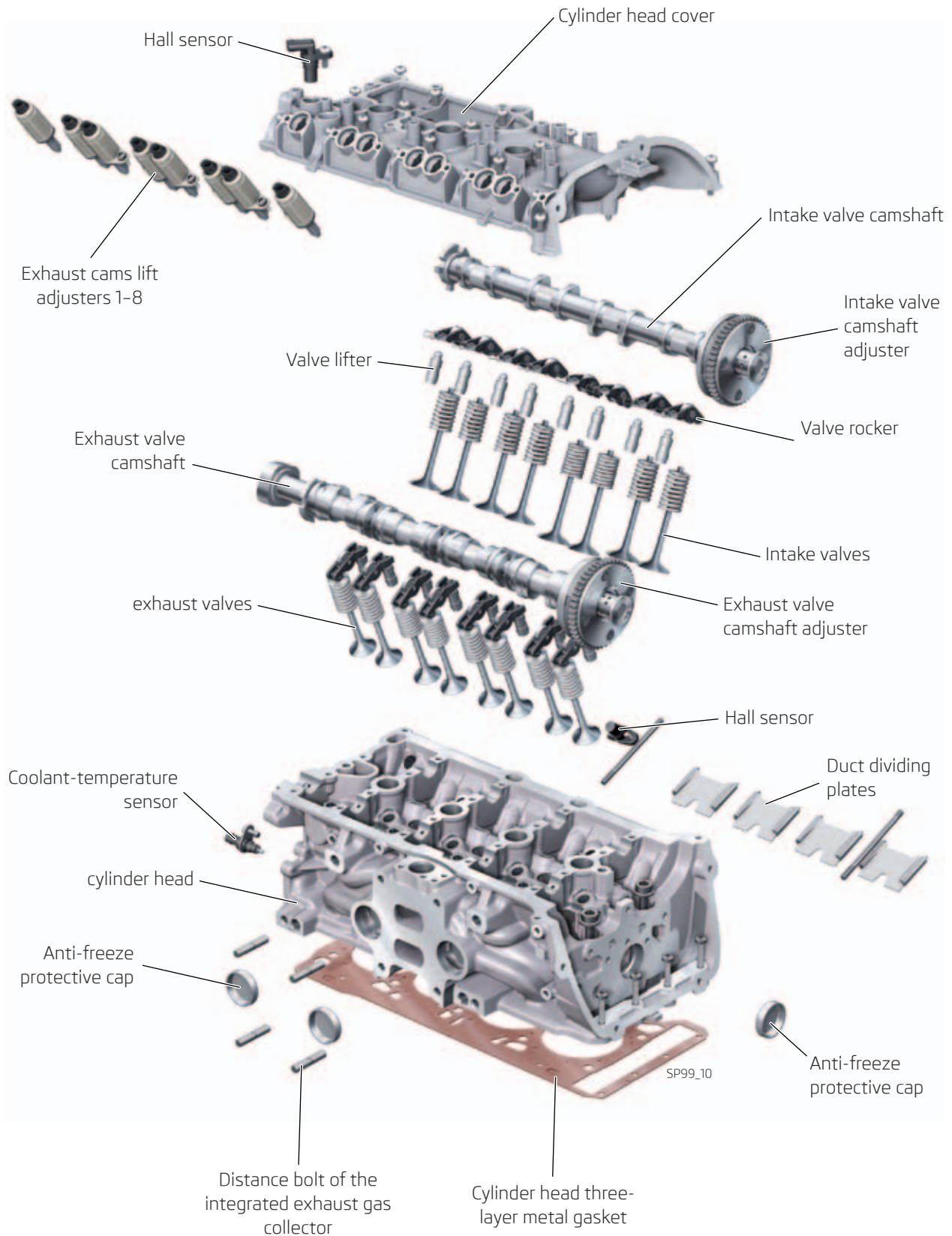

AVS Exhaust Valve System

The exhaust valve camshaft features two-stage valve lift switching. The lift switching system optimizes valve operation at various engine loads.

Exhaust gas valve camshaft adjuster

In addition to the two-stage valve switching, the camshaft also features a shaft adjuster. Those two adjusting systems help to achieve the maximum play levels when engine load changes. That results into faster torque increase and lower fuel consumption.

Sealing

The cylinder head cover is attached by steel bolts and sealed by a liquid sealant.

The sealing between **the head and the engine block** is provided by a three-layer metal gasket.

On the camshaft adjuster side, the engines are sealed by a plastic chain cover.



During cylinder head disassembly, it is necessary to remove the cylinder head cover first.

ŠKODA



5.2 Integrated Exhaust Gas Ducts

The exhaust gas ducts are now integrated in the cylinder head.

Use of these integrated exhaust ducts significantly reduces the temperature upstream of the turbine, compared to the regular routing. In addition, a turbocharger resistant to high temperature is used.

The integrated exhaust gas collector transfers its thermal energy to the coolant, which helps the engine reach its operating temperature faster.

Exhaust Gas Ducts

The exhaust gas ducts are designed in such a way that the exhaust gas flow leaving the cylinder does not interfere with the flushing of another cylinder. The exhaust ducts from cylinders 1 and 4 and 2 and 3 meet at the flange, which connects the turbocharger to the cylinder head. The total flow energy from all the cylinders is then available to drive the turbocharger turbine.

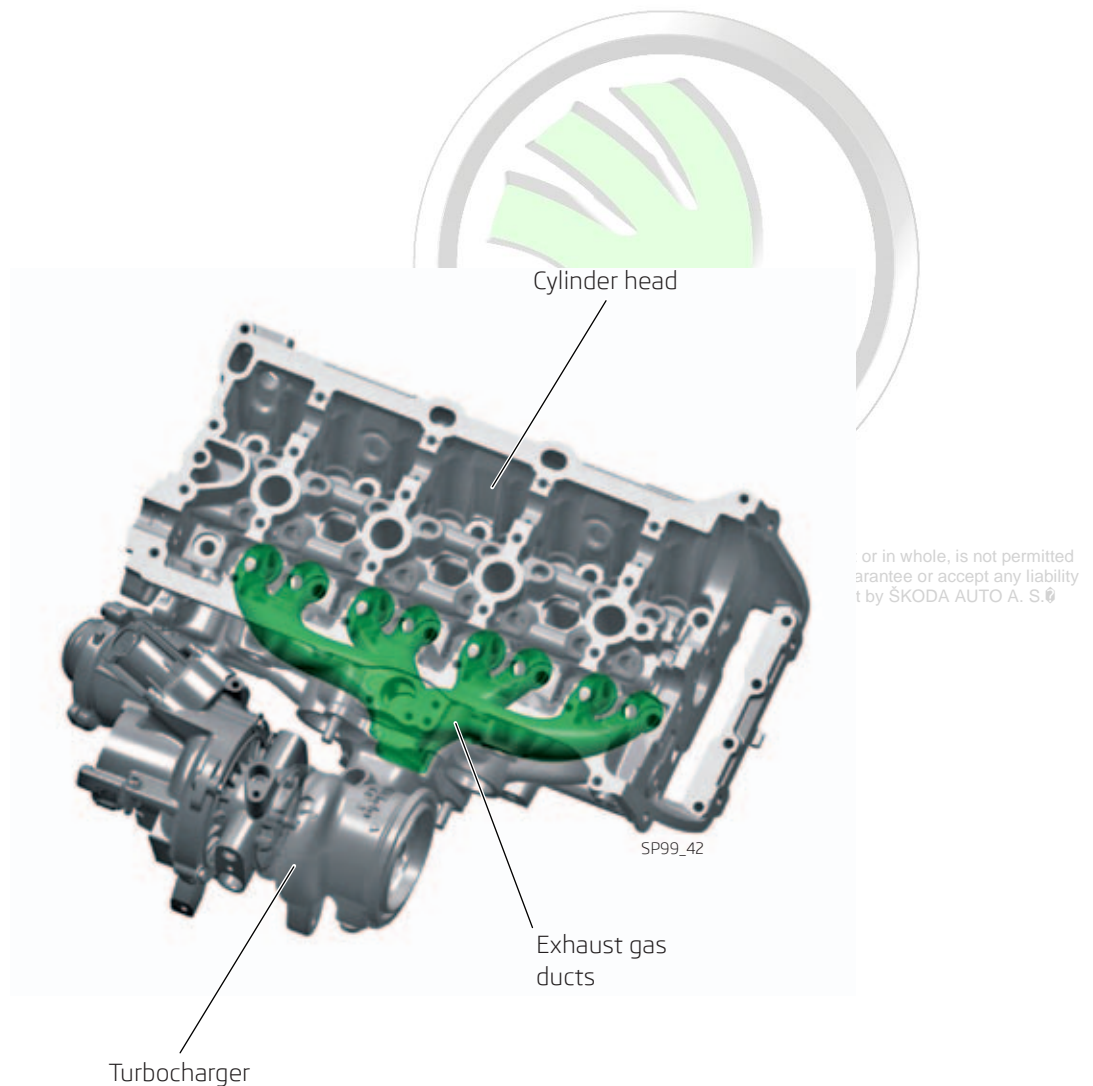

5.3 Integrated Exhaust Gas Ducts Cooling

The integrated exhaust gas collector supports quick coolant heating; therefore, it is a critical component of the engine's effective heat management.

After cold engine start-up, heat transfers from the exhaust gas collector to the coolant within a very short period. This heat directly heats the engine and car interior.

Thanks to this integration, heat is effectively transferred within the engine. The Lambda probe, exhaust gas turbocharger, and catalytic converter reach their optimum operating temperature quicker.

The short engine heating phase is followed by its cooling phase. Otherwise, coolant within the exhaust gas collector would quickly start boiling. For this reason, a coolant temperature sensor is installed at the cylinder head's hottest spot.

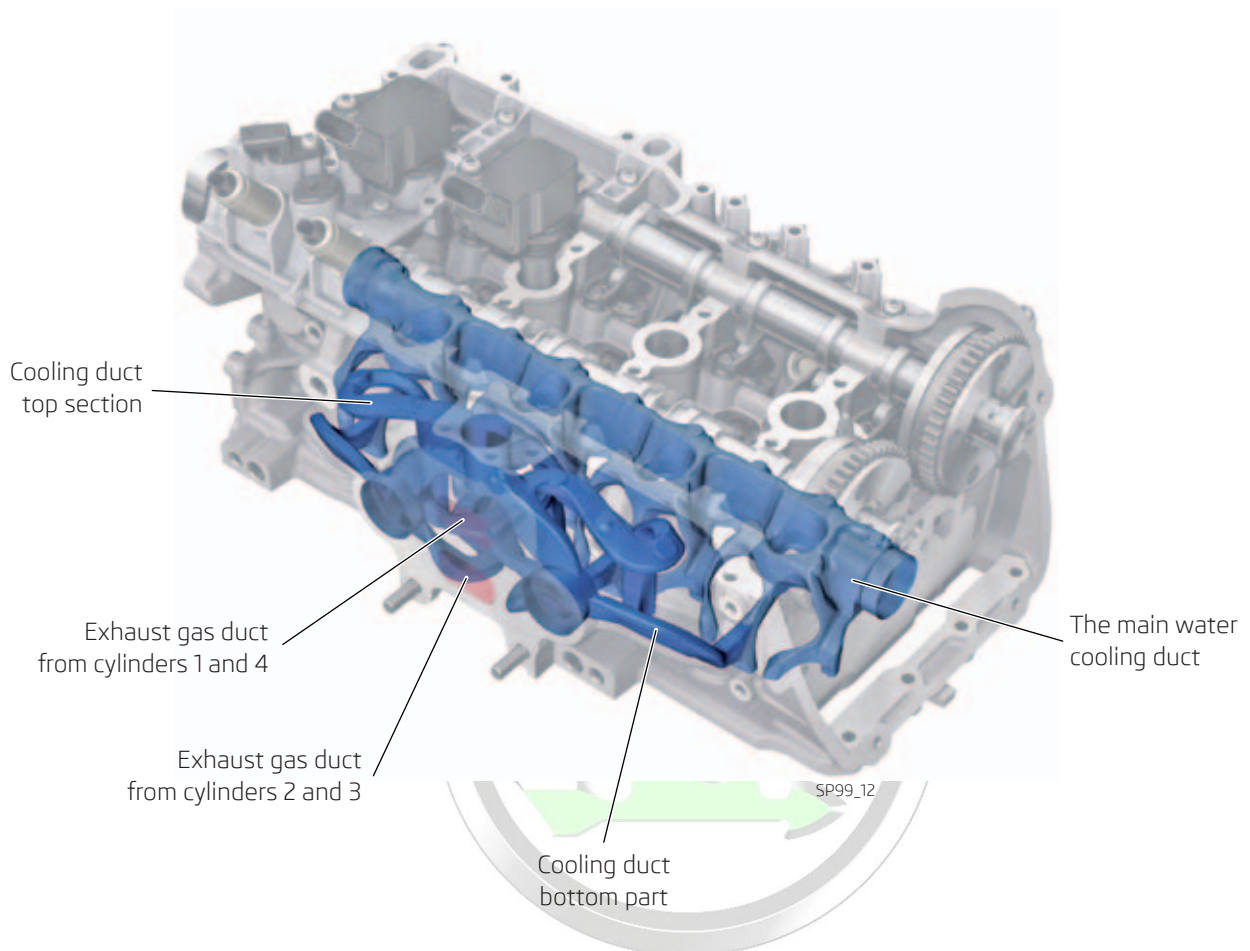

Protected by copyright. Copying for private or commercial purposes, in part or in whole, is not permitted unless authorised by ŠKODA AUTO A. S. ŠKODA AUTO A. S. does not guarantee or accept any liability with respect to the correctness of information in this document. Copyright by ŠKODA AUTO A. S. ©

6. Crank Mechanism

The crank mechanism for the 3rd generation of the EA888 series engines was designed to reduce weight and friction.

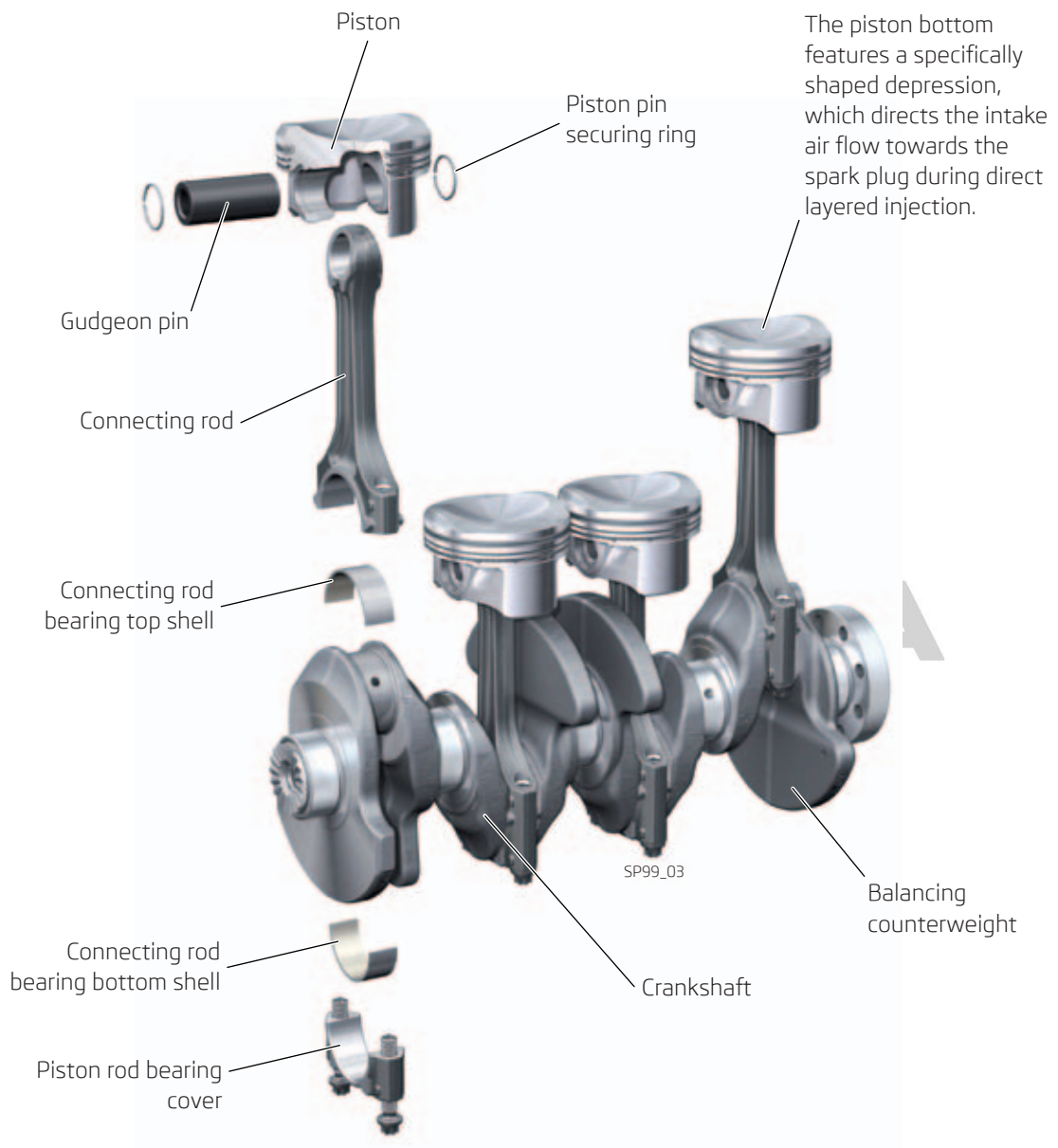

Protected by copyright. Copying for private or commercial purposes, in part or in whole, is not permitted unless authorised by ŠKODA AUTO A. S. ŠKODA AUTO A. S. does not guarantee or accept any liability with respect to the correctness of information in this document. Copyright by ŠKODA AUTO A. S. ©

6.1 Piston

Compared to the previous generation, the piston features increased play in order to reduce engine friction. The piston skirt features special wear-resistant coating. Three piston rings seal the piston inside the cylinder.

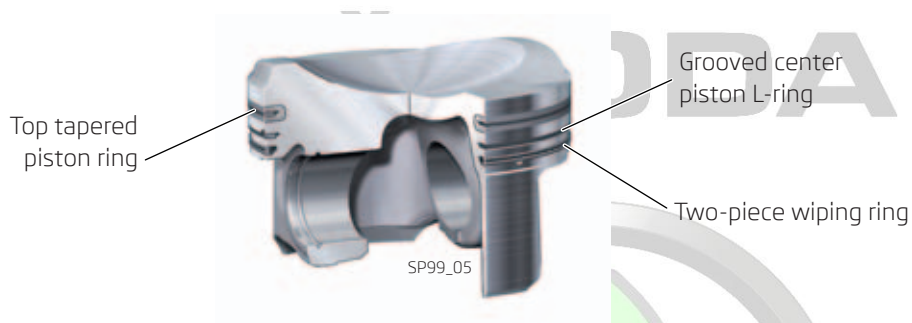

6.2 Connecting Rods

The whole engine exclusively features lead-free bearings. In the crank mechanism assembly, it applies to both the crankshaft main bearings and the connecting rod bottom eye bearings. Compared to the previous generation, there is no bronze bushing in the top connecting rod eye. The gudgeon pin features a special surface coating, and it runs directly through the steel connecting rod and the piston made of aluminium alloy.

Protected by copyright. Copying for private or commercial purposes, in part or in whole, is not permitted unless authorised by ŠKODA AUTO A. S. ŠKODA AUTO A. S. does not guarantee or accept any liability with respect to the correctness of information in this document. Copyright by ŠKODA AUTO A. S. ©



6.3 Crankshaft

Compared to the second generation, the crankshaft bearings have been downsized from 52 mm to 48 mm. The bearings are two-layer lead-free bearings.

6.4 Crankshaft Mounting

In addition to the attachment of the main crankshaft bearing cover to the cylinder block, the cover is also rigidly attached by bolts mounted to the oil sump top section. This design feature reduced the aggregate's vibrations and noise.

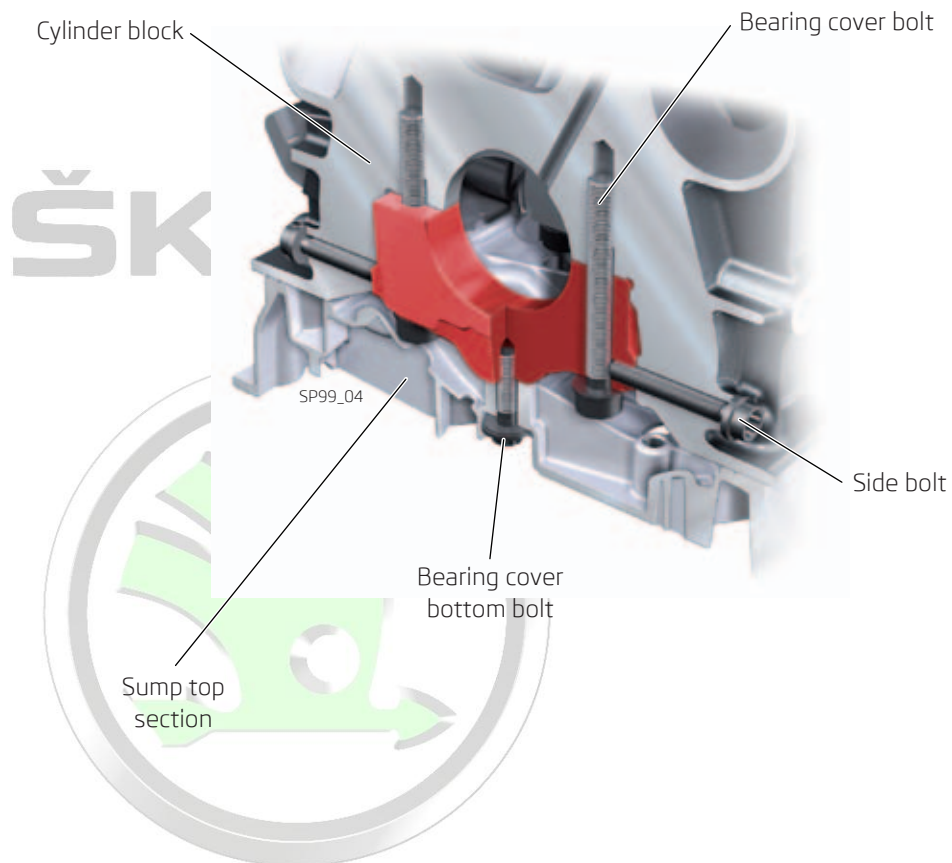

Protected by copyright. Copying for private or commercial purposes, in part or in whole, is not permitted unless authorised by ŠKODA AUTO A. S. ŠKODA AUTO A. S. does not guarantee or accept any liability with respect to the correctness of information in this document. Copyright by ŠKODA AUTO A. S. ©

7. Chain Timing Mechanism of the 1.8 TFSI Engine

The basic chain timing mechanism design does not differ from the previous engine generations. However, even the chain timing mechanism has been subject to thorough development. Due to reduced friction and lower oil consumption during engine lubrication, it was possible to reduce the power consumption of the timing mechanism. The chain tensioners have been modified to accommodate lower oil pressure in the system.

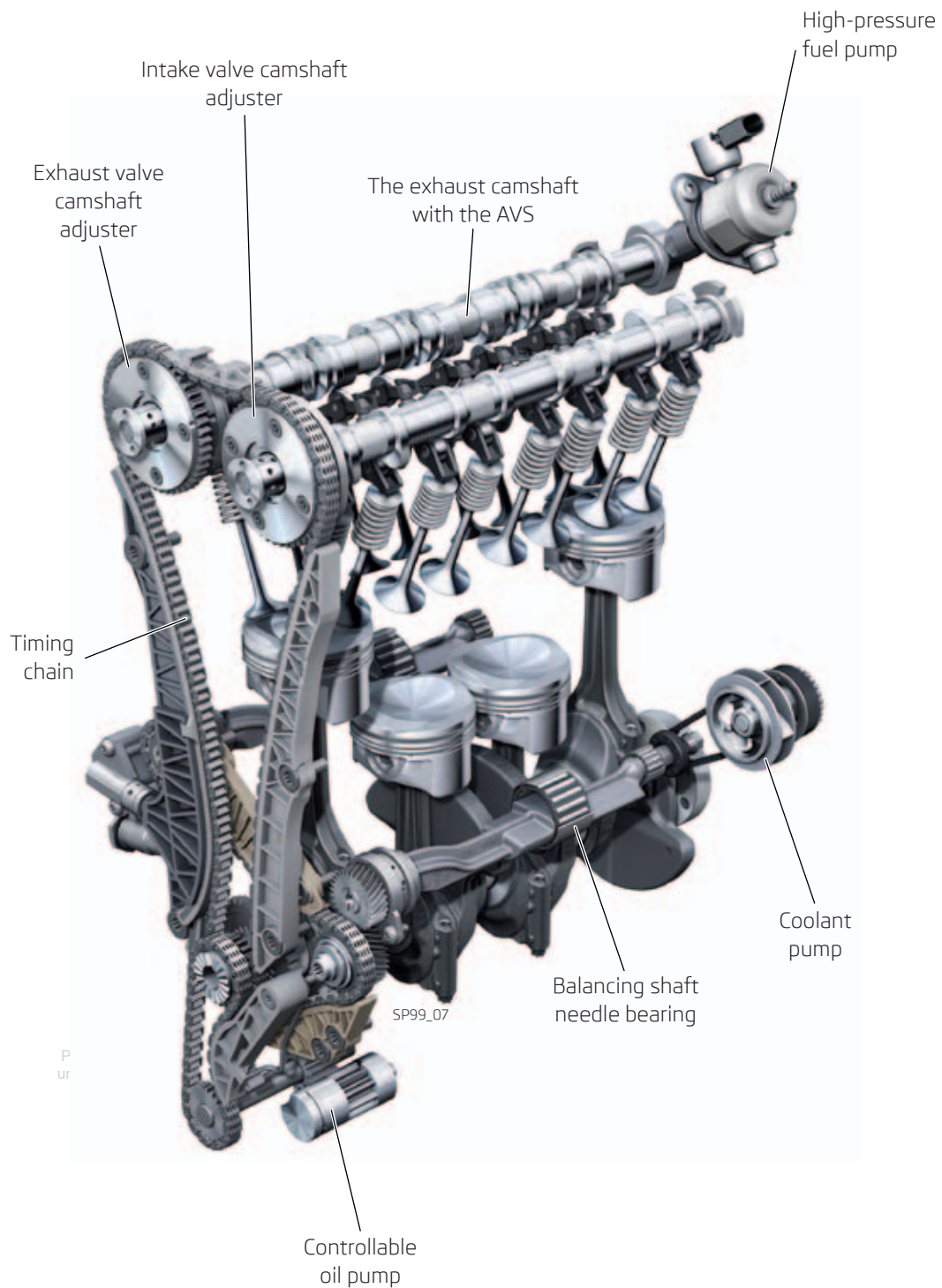

7.1 Balancing Shafts of the Chain Timing Mechanism

The balancing shafts' weight has been reduced. The shafts are partially supported by needle bearings now. This design feature significantly minimized chain assembly friction.

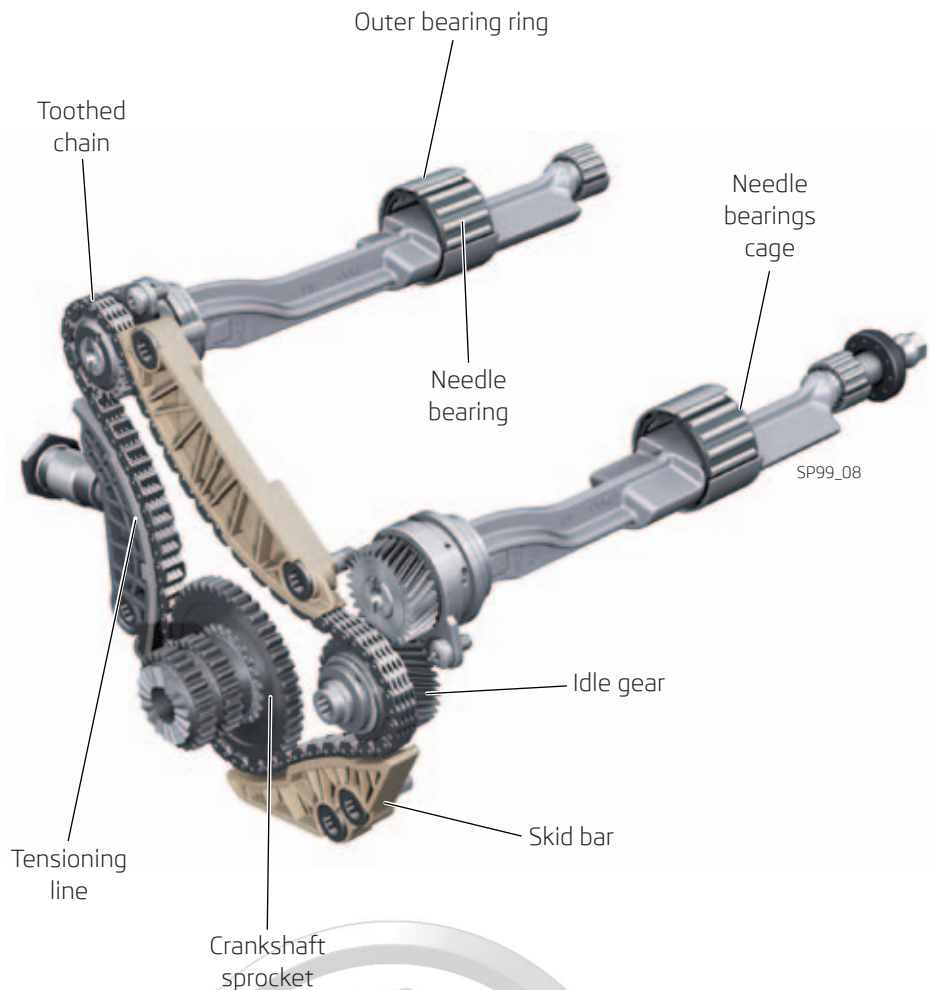

Reduced friction load of the timing mechanism has positive effect on the Start-Stop mode. Reduced friction also means reduced heat transfer in the system; therefore, lower oil operating temperature.

8. Fuel Injection

8.1 The Basic Fuel Injection Principles and the Combined Injection Rationale

While diesel engines with direct injection are characteristic with low CO emissions₂, they still produce large emissions of solid particles. Gasoline engines with direct injection may even produce more soot than comparable diesel aggregates.

That is why the 1.8 TFSI engine design features a dual injection system in order to **reduce emissions**.

The engine control unit activates one or the other injection system in order to effectively reduce the amount of solid particles and CO₂.

The engines combines direct injection with multi-point indirect injection:

- **FSI direct injection** (Fuel Stratified Injection)

High-pressure system, in which the injection valve is directed right into the combustion chamber.

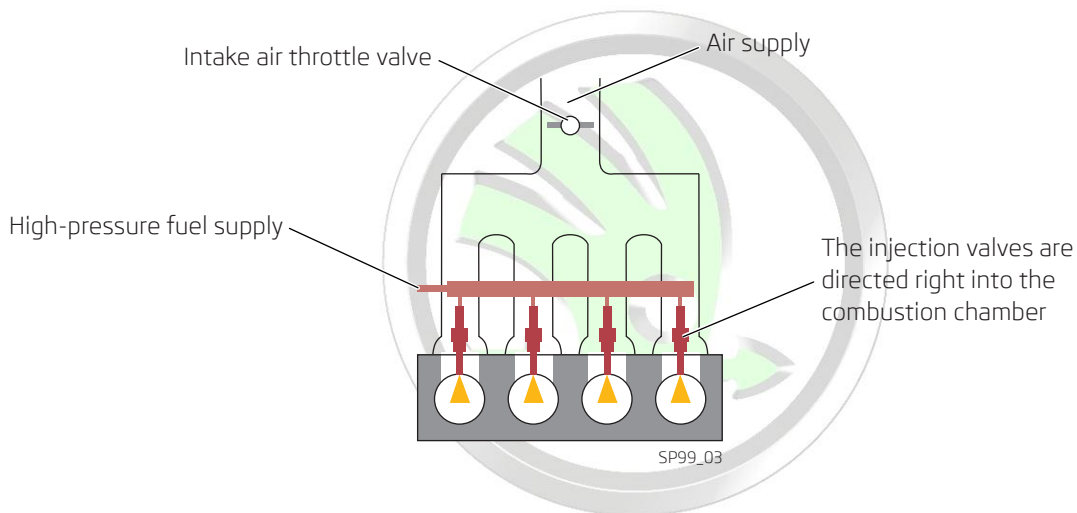

- **MPI indirect multi-point injection** (Multi Point Injection)

Low-pressure system, in which the injection valve is directed to the subject cylinder's intake duct. It injects fuel upstream the cylinder intake valve.

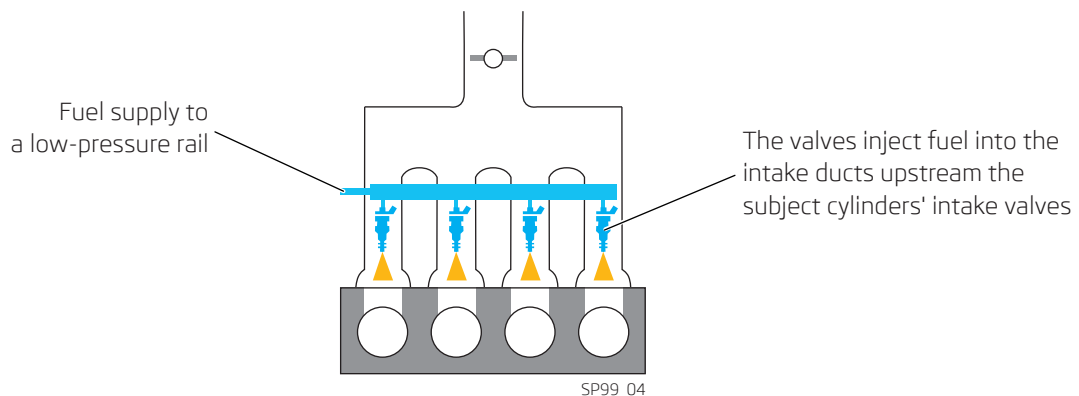

8.2 Combined Fuel Injection System Design

Use of the combined injection in the new engine design brought the following benefits:

- FSI injection system pressure increased to 200 bar (new high-pressure system design)
- Reduced engine noise (separation of the FSI injection valves from the cylinder head through flexible washers)
- Compliance with Euro 6 emission standard, reduced amount of solid particles and CO₂ (fuel injection split between the MPI system and the FSI system, based on the engine's torque characteristics)
- MPI precise injection into the compartment upstream the intake valve (suction duct modification and MPI injection valves installation)
- Reduced consumption at partial engine load (MPI injection mode application)

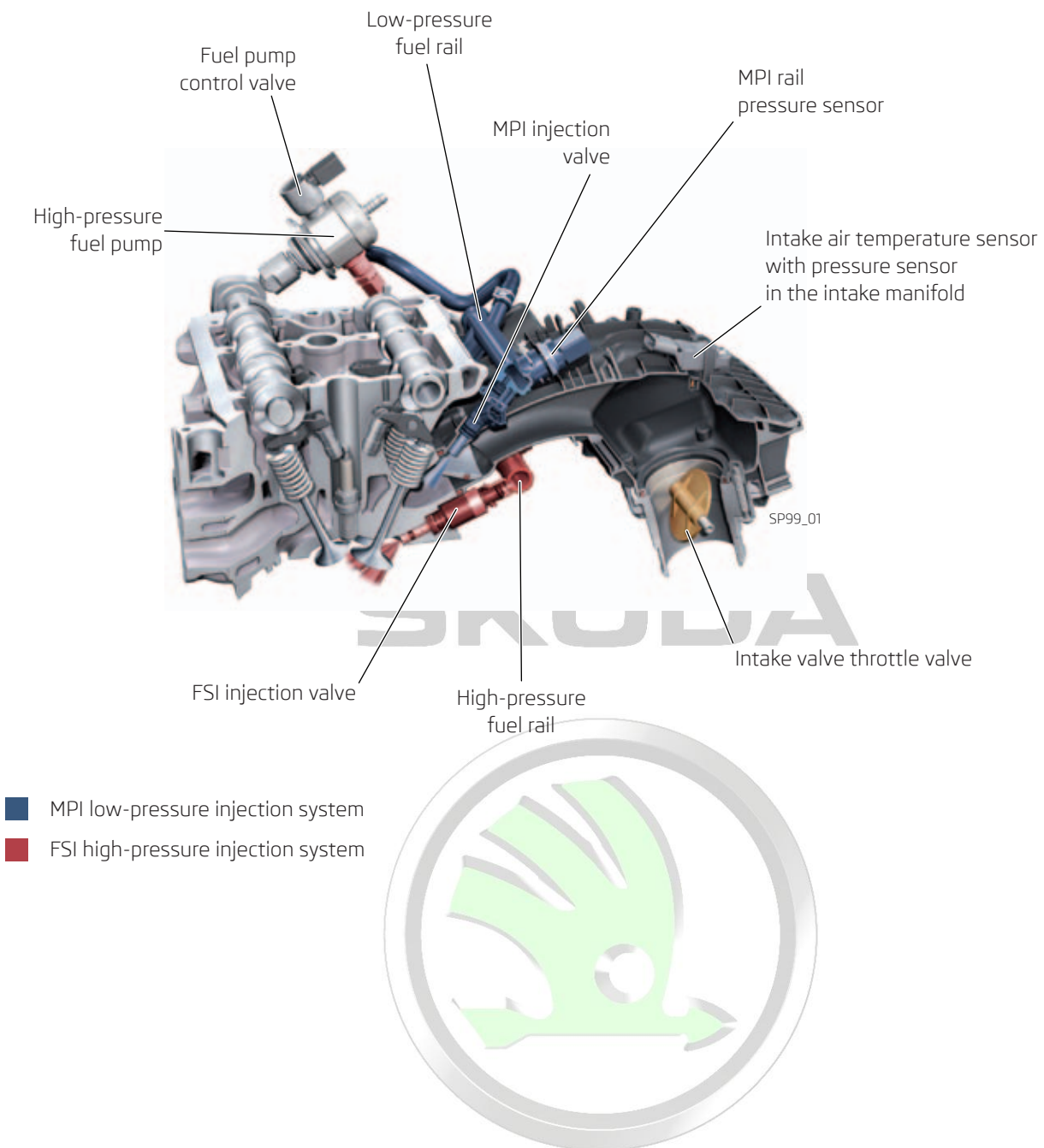

Protected by copyright. Copying for private or commercial purposes, in part or in whole, is not permitted unless authorised by ŠKODA AUTO A. S. ŠKODA AUTO A. S. does not guarantee or accept any liability with respect to the correctness of information in this document. Copyright by ŠKODA AUTO A. S. ©

8.2.1 The FSI High-Pressure Fuel Injection System

The system pressure has been increased to 200 bar; therefore, all the high-pressure system components have been modified. The valves are newly mounted by steel shims. That has reduced acoustic surges during injection. Those surges used to hit the cylinder head before. The high-pressure rail is newly attached to the cylinder head and not to the intake, as before.

The high-pressure injection valves have been moved backwards (away from the engine head). That improved mixture homogenization and also reduced valve thermal load.

High-Pressure Pump Cooling

The high-pressure pump is cooled. The coolant is fuel, which supplies the MPI low-pressure rail and flows through it. As a result, even during the MPI regime, the pump is automatically flushed with fuel; therefore, cooled.

To minimize pulsations transmitted from the high-pressure pump into the MPI fuel supply, a throttle valve is fitted in the supply line.

8.2.2 The MPI Low-Pressure Fuel Injection System

The MPI system features its own pressure sensor located in the MPI rail. Both the rail and the intake manifold are made of plastic. The MPI injection valves are integrated into the intake manifold, so the injected fuel beams are perfectly centered in the compartment upstream the intake valves.

Protected by copyright. Copying for private or commercial purposes, in part or in whole, is not permitted unless authorised by ŠKODA AUTO A. S. ŠKODA AUTO A. S. does not guarantee or accept any liability with respect to the correctness of information in this document. Copyright by ŠKODA AUTO A. S. ©



If the engine has run in the MPI mode for a longer period of time, the FSI injection mode is briefly activated in order to avoid fuel carbonization in the FSI high-pressure injection valves.

8.3 Injection Modes in Dependence on Engine Load Type

The SP99_02 diagram on this page displays the areas of the MPI or FSI injection modes for each particular operating point defined by particular combination of engine speed and load. The number and mode of the individual injections (MPI or FSI) are subject to thermodynamic optimization in order to minimize soot emissions.

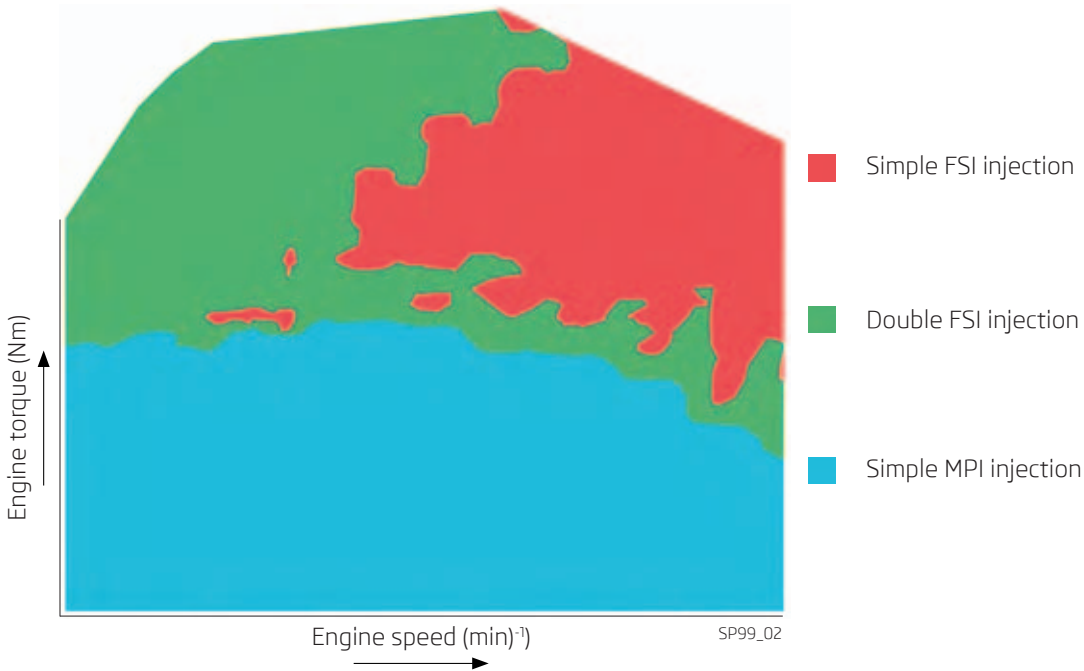

Engine mode:	Injection mode
Engine start	FSI Triple direct injection (three times during the compression stroke)
Cold engine (cooling liquid temperature below 45 °C)	FSI Simple direct injection (once into the intake stroke)
Warm engine operation	FSI Double direct injection (one into the intake stroke and one into the compression stroke)
Warm engine (cooling liquid temperature above 45 °C) – partial engine load	MPI Simple injection
Warm engine (cooling liquid temperature above 45 °C) – Higher engine load	FSI Double direct injection (one into the intake stroke and one into the compression stroke)



If one of the fuel injection systems fails, the other system will take over in the emergency operating mode. That ensures that the vehicle will remain operational.

poses, in part or in whole, is not permitted unless authorised by SKODA AUTO A. S. SKODA AUTO A. S. does not guarantee or accept any liability with respect to the correctness of information in this document. Copyright by ŠKODA AUTO A. S. ©

8.4 Fuel System Diagram

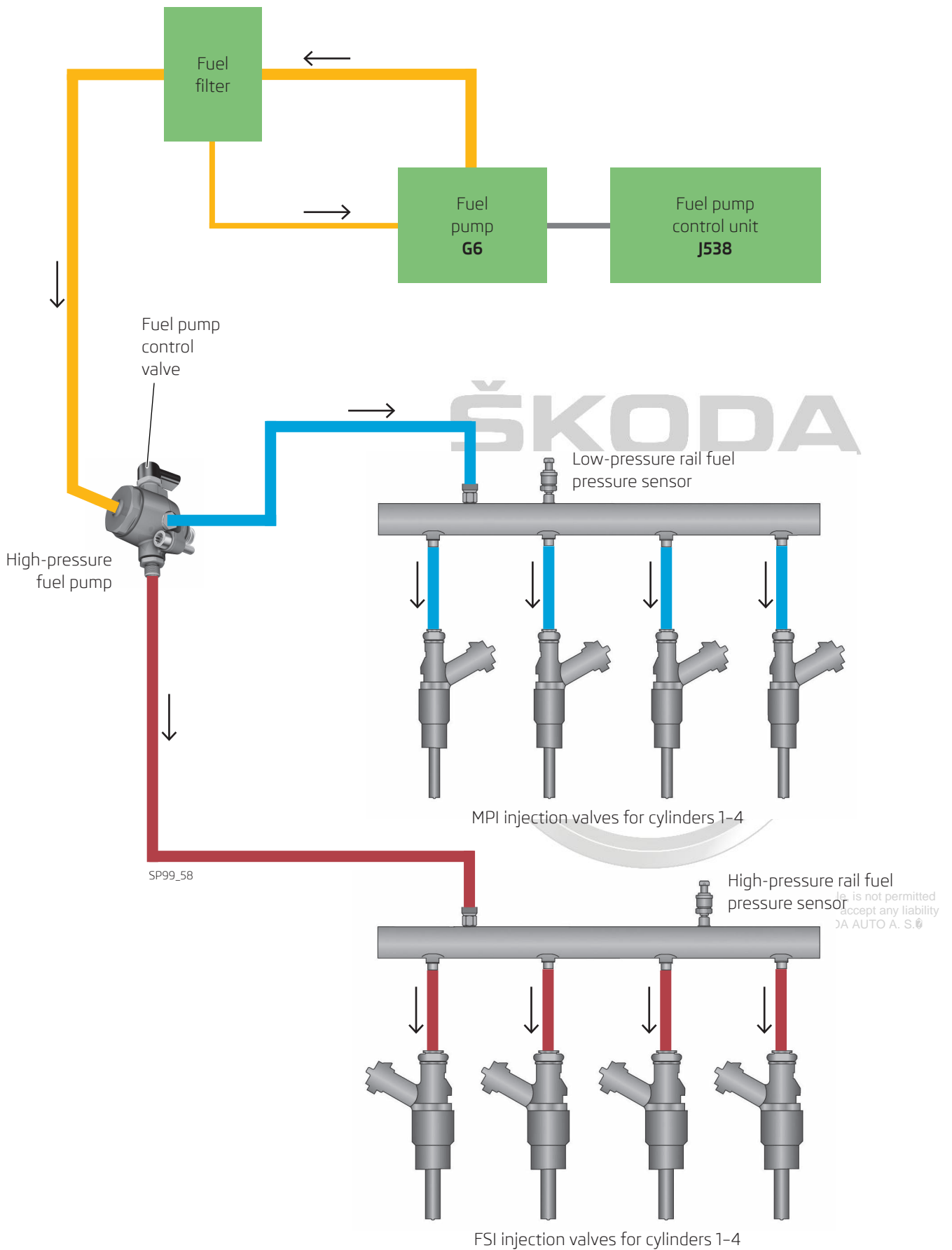

9. Cooling System

Modernized ITM temperature management*

During the 1.8 TFSI engine development, the whole cooling system was redesigned. The designers primarily strove to achieve quick engine heating, fuel consumption reduction through quick and thermodynamically optimal engine temperature regulation, including potential interior heating.

The modernized temperature control of the 1.8 TFSI engine is based on two key components. The first one is **the exhaust gas collector integrated in the cylinder head**, the other one is **the rotational valve module/N493, which controls the engine temperature.**

9.1 Coolant Pump and Engine Temperature Regulation Controller

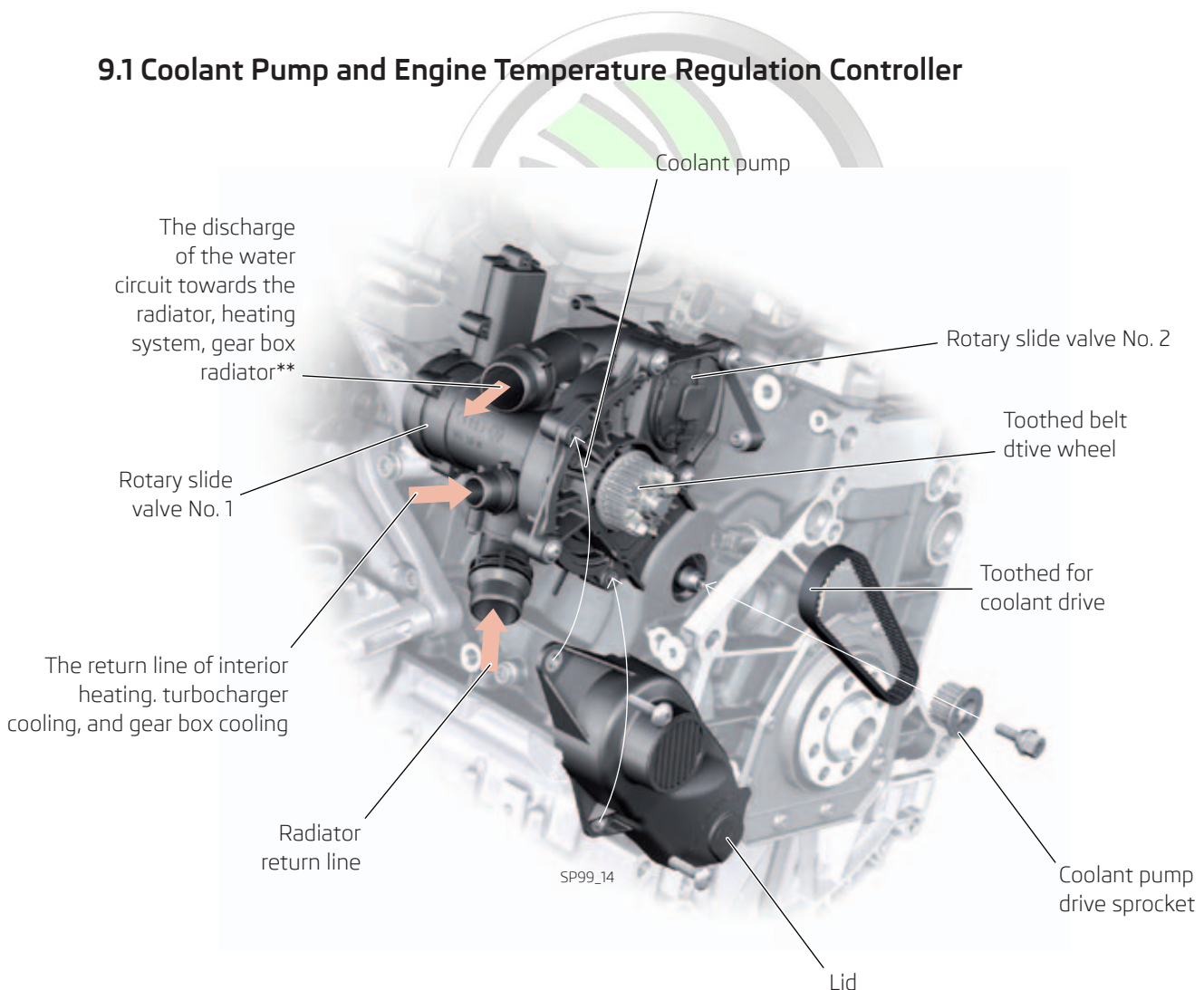

The N493 rotational valve module, which regulates engine temperature, forms one assembly with the coolant pump. It is located on the engine's cold side.

* intelligent thermal management

** for automatic transmission for 4 x 4 vehicles

9.2 Engine Temperature Regulation Controller

The rotary engine temperature controller N493 controls coolant flow by the two mechanically connected rotational valves. The subject valve position directs or completely stops the flow into the individual cooling system components. The control unit uses the valve system to effectively control the engine temperature modes. The rotational valves are actuated by a DC motor, which is controlled by signals from the control unit.

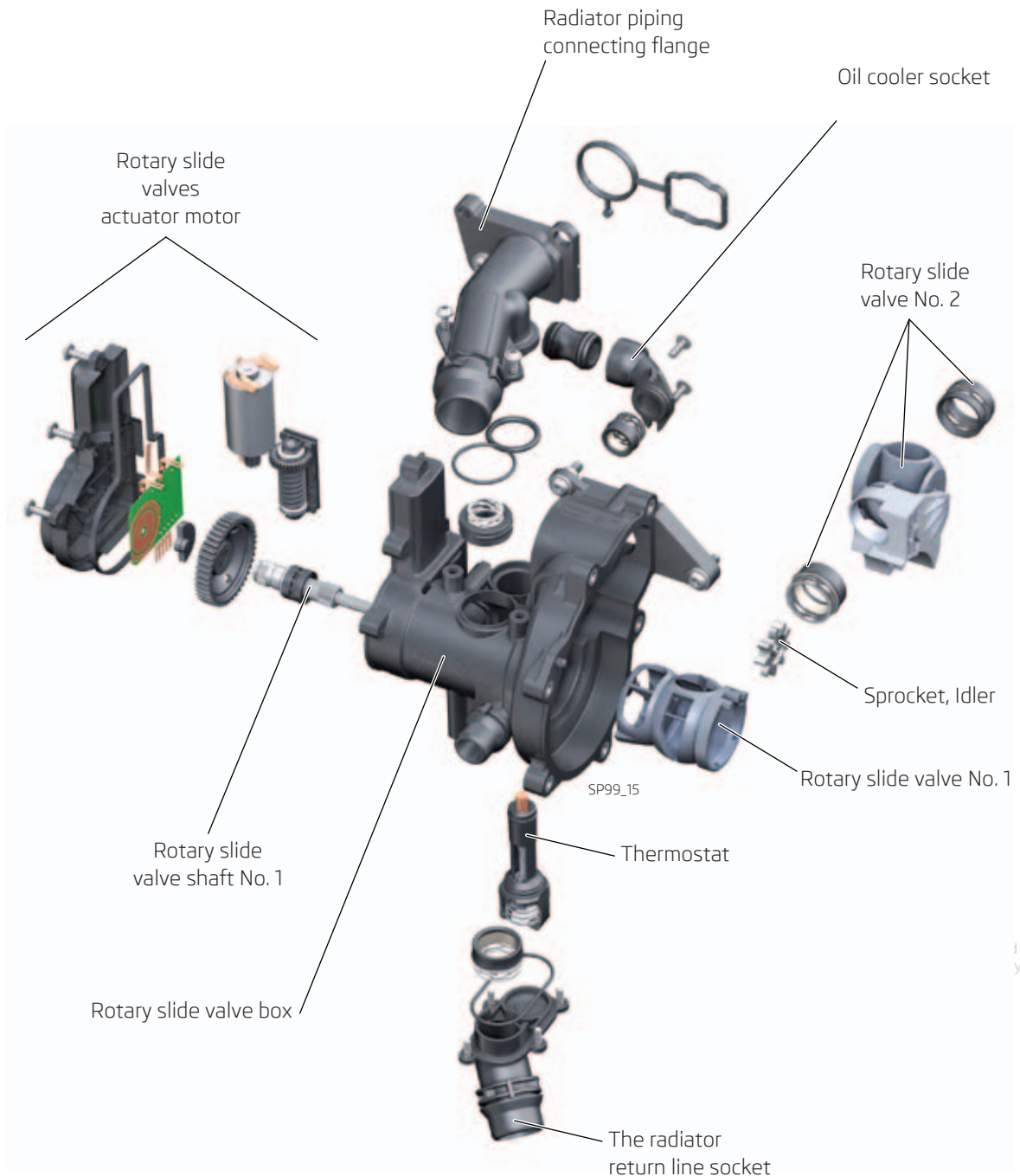

The DC motor drives valve No. 1 through a worm gearing. The electric motor is controlled by the engine control unit 12 V signal of 1 Hz frequency. PWM digital signal is used. The rotational valve module controls the flow of coolant to the oil cooler, the cylinder head, and the main water radiator.

The valve module does not regulate the gear box radiator, turbocharger, or interior heating.

Valves No. 1 and 2 are mechanically connected. Rotating valve No. 1 opens valve No. 2 at a specific working angle.

Valve No. 2 then closes at another angle.

Rotational valve No. 2 opens the cylinder block cooling line.

- Valve No. 2 starts opening when valve No. 1 turns by the 145°.
- Valve No. 2 starts closing when valve No. 1 turns by additional 85°. At this point, valve No. 2 reaches the maximum opening of the cylinder block cooling circuit.

The warmer the engine is, the more the rotational valves turn. The mechanical stoppers limit the end positions of the rotational valves.

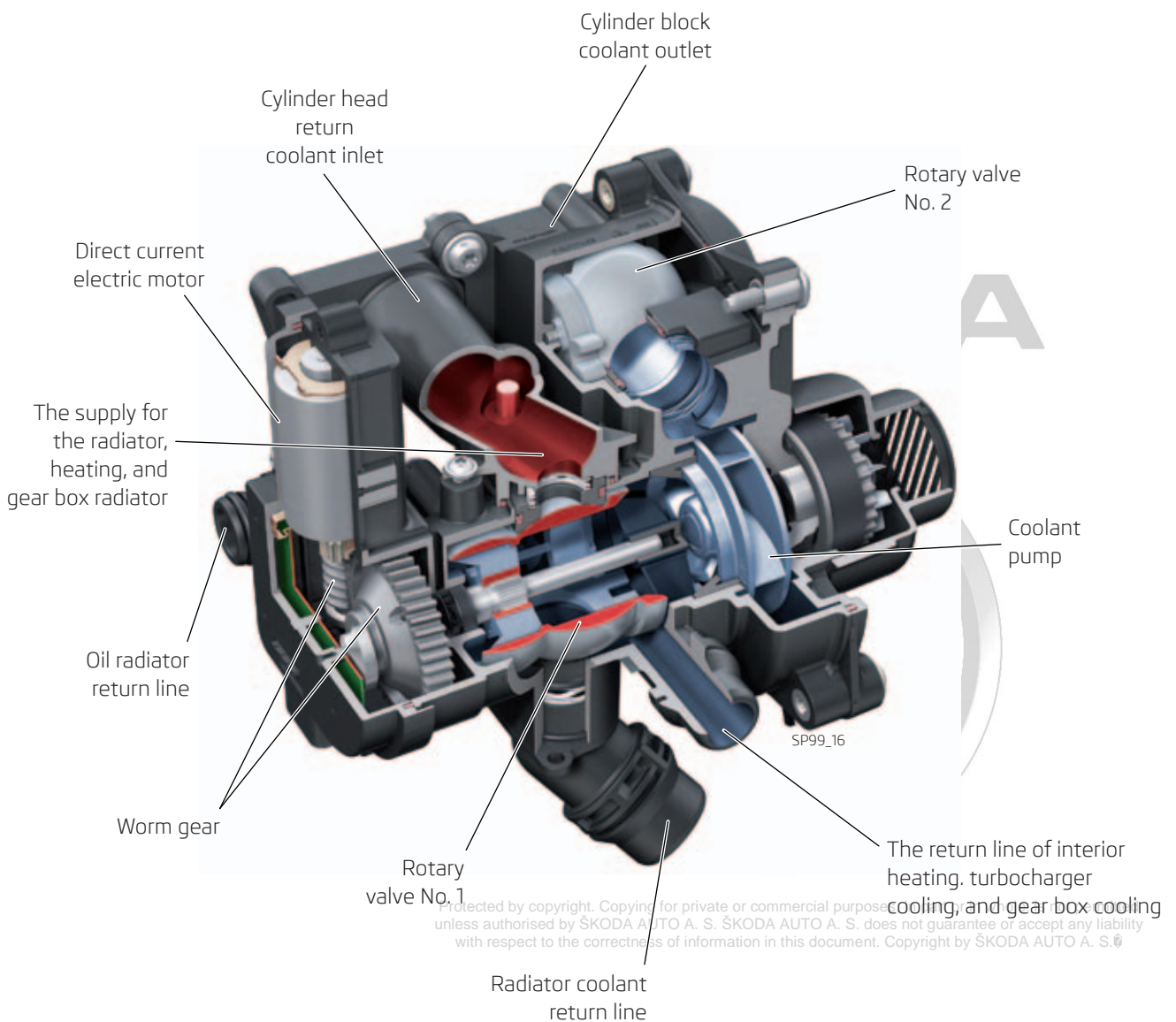

Protected by copyright. Copying for private or commercial purpose unless authorised by ŠKODA AUTO A. S. ŠKODA AUTO A. S. does not guarantee or accept any liability with respect to the correctness of information in this document. Copyright by ŠKODA AUTO A. S. ©

9.3 Engine Temperature Regulation Controller Modes

The following text describes the individual water circuit operating modes triggered by the engine temperature controller during engine heating.

Cold-Engine Quick Warm Up Mode

During cold engine heating, valve No. 1 is set to the angle of 160°. In that position, valve No. 1 closes the engine oil cooler inlets and the main water radiator return line.

Rotational valve No. 2 closes the cylinder block supply.

The Climatronic shut-off valve and the gearbox cooling valve are closed. The auxiliary coolant pump is off. As a result, no coolant circulates in the cylinder block. Based on load and RPM, the non-circulating coolant in the cylinder block is thus quickly heated up to the temperature of 90 °C.

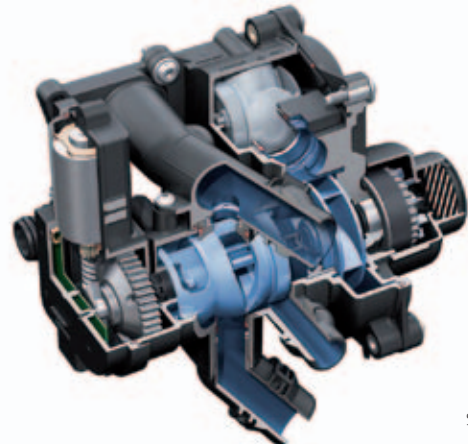

SP99_17

Passenger Space Quick Warm Up Mode

If it is required to heat the interior, the Climatronic shut-off valve and the auxiliary coolant pump are activated. As a result, the coolant flows through the cylinder head, turbocharger, and the heat-exchanger that heats the car interior.

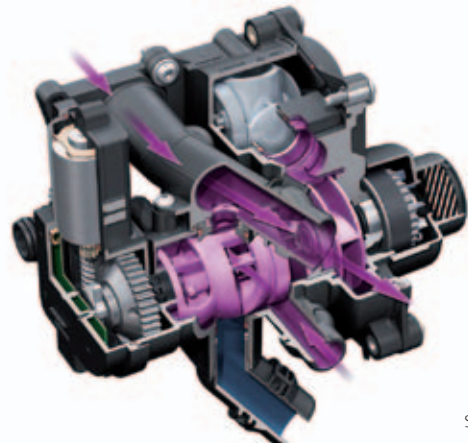

SP99_19

Minimum Flow-Rate Mode for Cylinder Head Protection

The purpose of this feature is to protect the cylinder head and turbocharger from overheating.

If it becomes necessary to quickly cool down the cylinder head or turbocharger after abrupt engine heating in the quick heat-up mode without coolant circulation, rotational slide valve is set to the angle of 145°. Once that angle is reached, the permanent gear between the valves engages with the rotational valve No. 2 and opens it up. A small amount of coolant will immediately start flowing into the cylinder head, turbocharger, and rotational valve module and back to the coolant pump. The remaining coolant will proceed through the shut-off valve to the interior heat exchanger if needed.

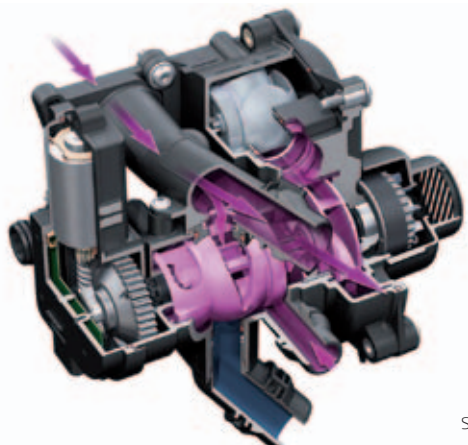

SP99_20

Engine Oil Cooler Socket

Later during the heating phase process, the engine oil cooler inlet valve opens. Rotational valve No. 1 is set to the 120° angle. Simultaneously, rotational valve No. 2 opens, and the coolant flow through the cylinder block intensifies. By intentional supply of hot coolant to the oil cooler, the engine oil temperature starts increasing.

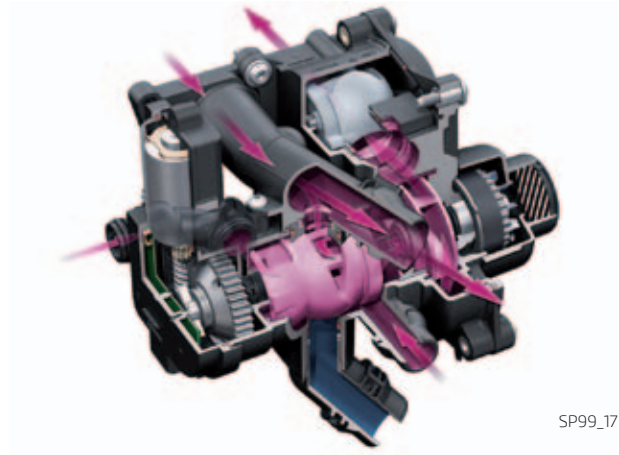

SP99_17

Gear Oil Heating

Once the aggregate is sufficiently heated, the automatic transmission coolant valve finally opens in order to deliver excess heat to the gear box oil.

The gear box oil heating starts once the coolant reaches the temperature of 80 °C without heating or 97 °C with heating.

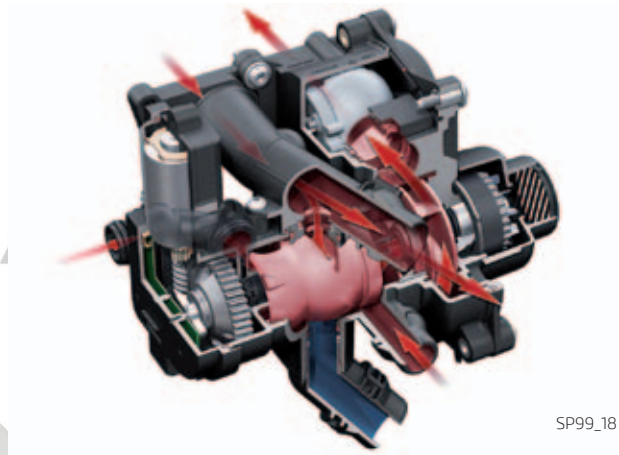

SP99_18

Temperature control by the main water radiator

At low RPM and minimum load, the coolant temperature is set to 107 °C in order to minimize engine friction.

Under increased load and RPM, the coolant temperature is reduced to 85 °C.

Rotational valve No. 1 is set in the angle range of 80° - 0°, as needed. Once rotational valve No. 1 reaches the angle of 0°, the water return line to the water radiator becomes fully open.

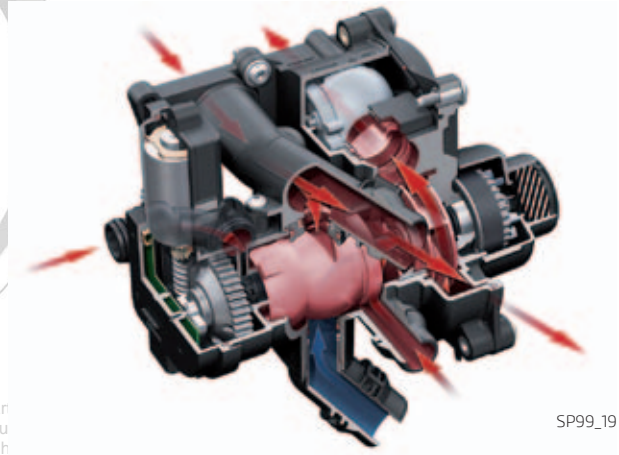

SP99_19

Protected by copyright. Copying for private or commercial purposes, in part or in full, is prohibited without the written permission of ŠKODA AUTO A. S. ŠKODA AUTO A. S. does not guarantee the correctness of information in this document. Copyright

Aftercooling Mode after Engine Shutdown

If needed after engine shutdown, the aftercooling function becomes activated. Its purpose is to avoid coolant boiling in the cylinder head and turbocharger, or unnecessary engine cooling. The function may only become active 15 minutes after engine shutdown. During aftercooling, the rotational valve is set within the range of 160 - - 255°; the coolant temperature regulation remains active even in this mode. If intensive aftercooling and low coolant temperature are required, the water radiator return line will open; however, rotational valve No. 2 will close the cylinder block supply piping. Simultaneously with that, the auxiliary coolant pump and coolant shut-off valve are activated. Now, the coolant is flowing in two directions - through the cylinder head to the coolant pump and the turbocharger, rotational valve No. 1, and water radiator back to the auxiliary coolant pump. This feature significantly shortens the aftercooling period without any excess heat loss.

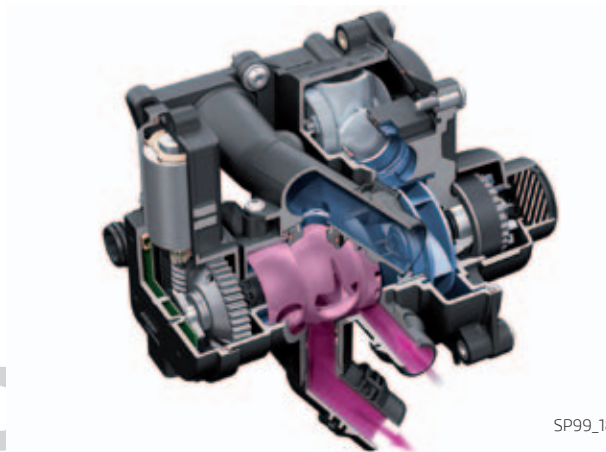

SP99_18

Engine Temperature Controller Failure

If the angle sensor fails, the rotational valve is fully activated (maximum engine cooling).

If the DC motor is defective or the rotational valve is stuck, engine RPM and torque become limited, based on the rotational valve's position.

If the temperature inside the controller exceeds 113 °C, the thermostat will open the bypass valve to the water radiator in order to let all the coolant flow through it.

If the regulator fails, the vehicle may continue driving without any engine damage risk.

System malfunction visualization:

- The instrument cluster display will display a maximum engine RPM limitation notification
- The displayed notification is accompanied by sound annunciation and EPC failure indicator activation
- Actual coolant temperature indication on the instrument cluster

10. Air Intake System with a Turbocharger

10.1 System Diagram

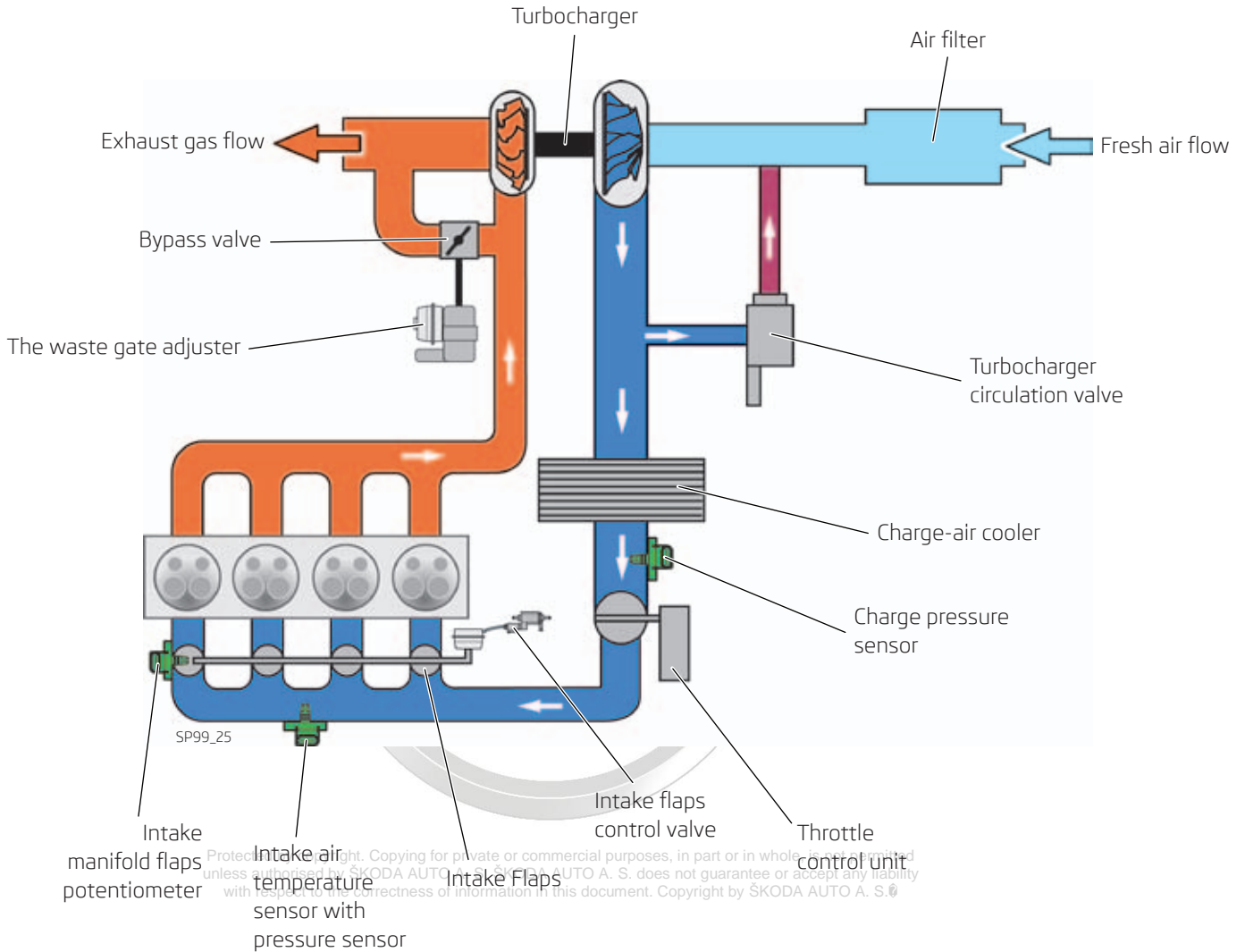

- Exhaust manifold
- Intake air
- Charge air
- Circulating air

The air filter removes mechanical impurities from the intake air. The air proceeds through the low-pressure section to the compressor blades. The compressor is powered by the exhaust gas turbine. Then, the air proceeds through the high-pressure section. The air cooler is installed upstream the main intake throttle. Cooling decreases the air molecules volume and mixture explosiveness in the combustion chamber. Which, in the case of a gasoline engine, might cause undesirable self-ignition. Then, the already cooled and compressed air proceeds to the individual intakes of the subject cylinders.

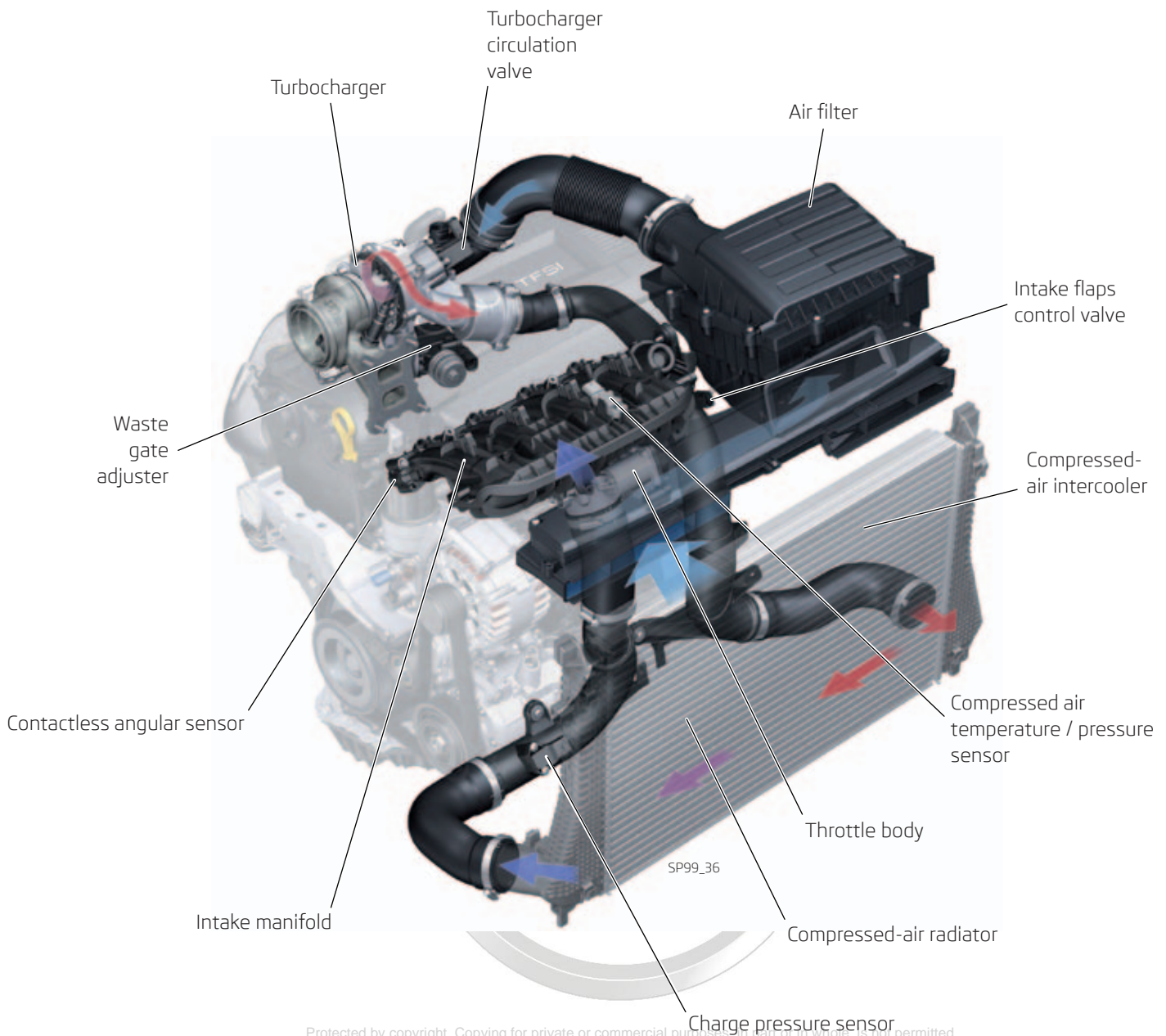

Protected by copyright. Copying for private or commercial purposes, in part or in whole, is not permitted unless authorised by ŠKODA AUTO A. S. ŠKODA AUTO A. S. does not guarantee or accept any liability with respect to the correctness of information in this document. Copyright by ŠKODA AUTO A. S. ©

The turbocharger is driven by the exhaust-gas powered turbine. The engine water lines decrease the exhaust gas temperature as they are flushing integrated exhaust gas ducts. As a result, the turbocharger thermal load decreases.

10.2 Intake Manifold Design

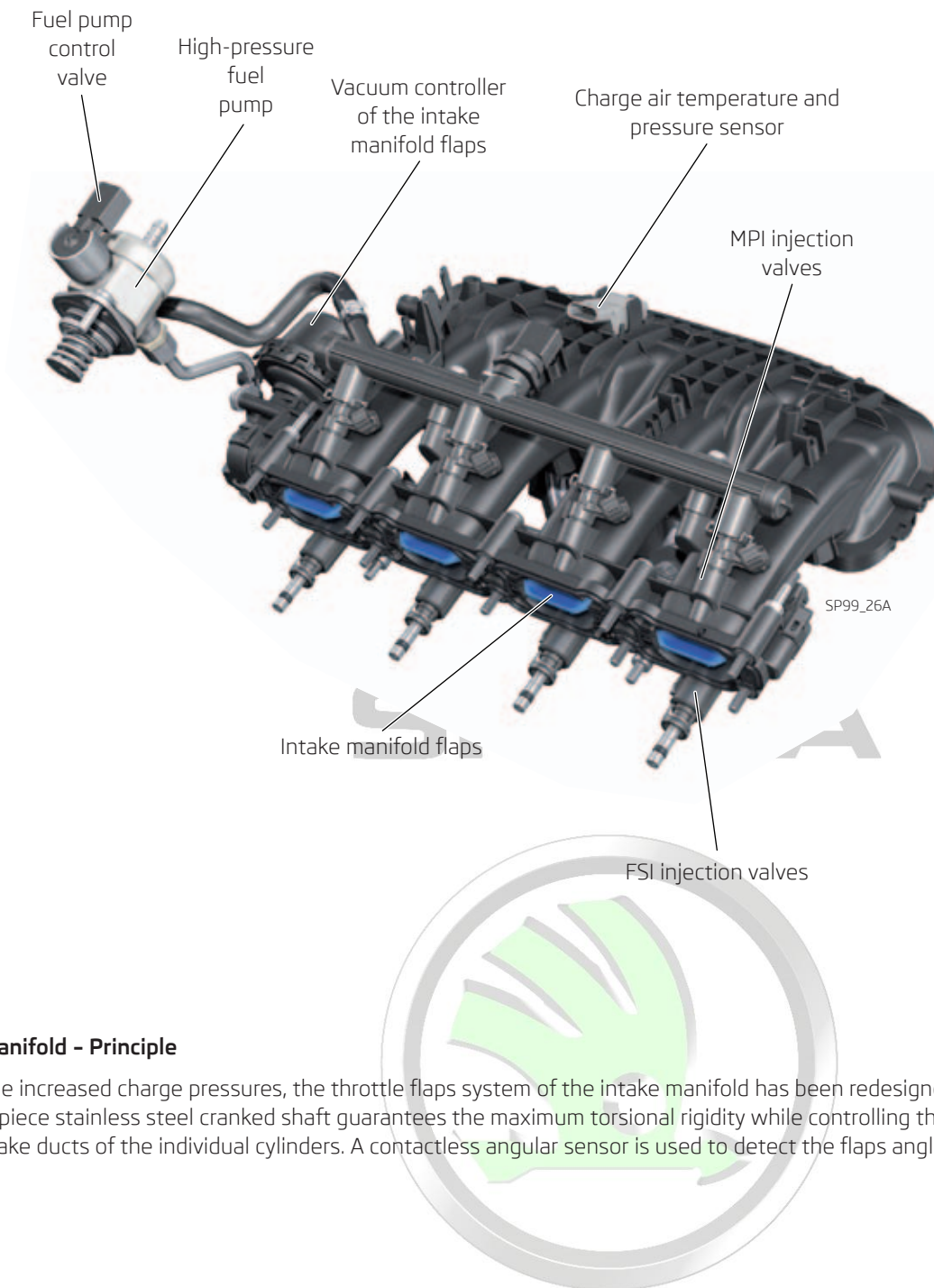

Intake Manifold - Principle

Due to the increased charge pressures, the throttle flaps system of the intake manifold has been redesigned. The one-piece stainless steel cranked shaft guarantees the maximum torsional rigidity while controlling the flaps in the intake ducts of the individual cylinders. A contactless angular sensor is used to detect the flaps angle.

Protected by copyright. Copying for private or commercial purposes, in part or in whole, is not permitted unless authorised by ŠKODA AUTO A. S. ŠKODA AUTO A. S. does not guarantee or accept any liability with respect to the correctness of information in this document. Copyright by ŠKODA AUTO A. S. ©

When open flaps match the intake duct shape. The flaps are electro-pneumatically controlled. The control unit controls the intake flaps control valve, which controls the vacuum actuator of the intake flaps.

ŠKODA

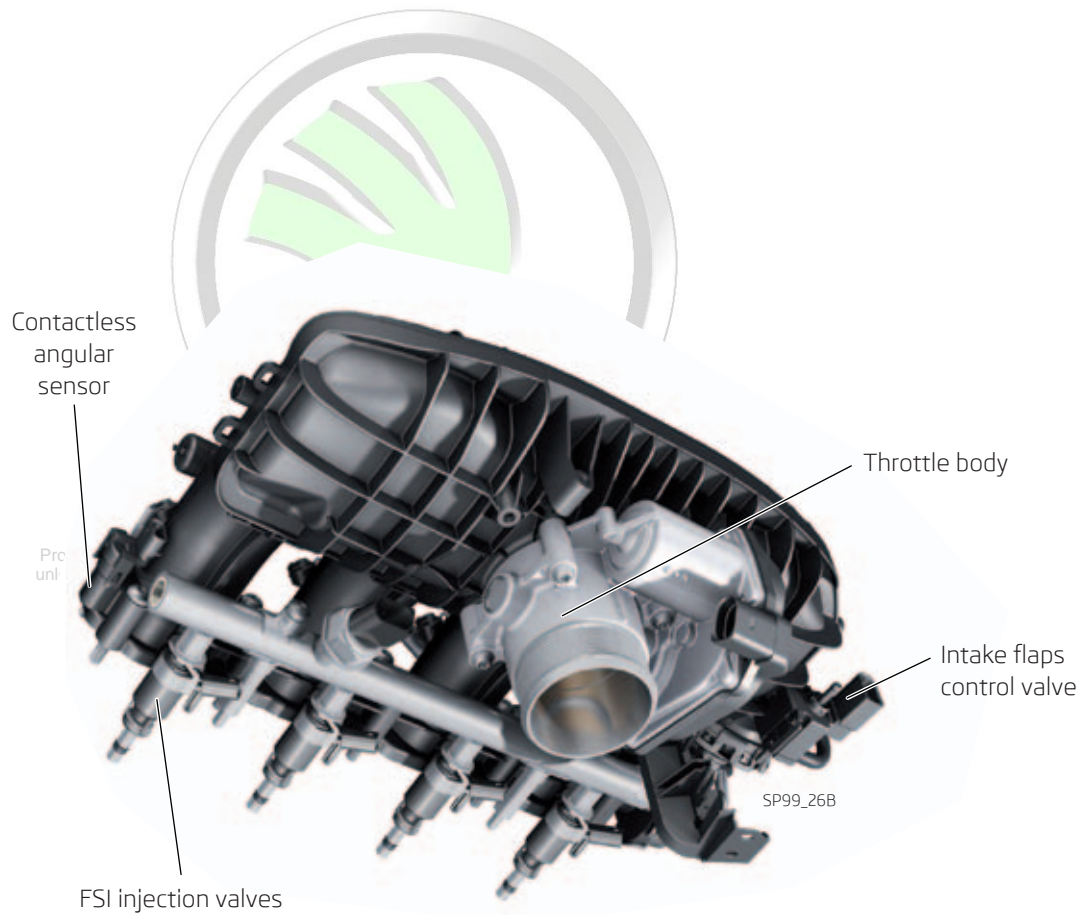

10.3 Turbocharger

Charging the engine using a turbocharger enables the engine to deliver maximum torque within a wide RPM range and improves the engine parameters under its full load.

The two cylinder head outlet exhaust gas ducts only join behind the turbocharger flange; therefore, shortly prior to the turbine. As a result, the exhausts from the individual cylinders are separated as much as possible.

The new turbocharger has the following features:

- Electric waste gate controller
- Lambda probe upstream of turbine
- Compact turbine casing with dual inlet, mounted directly to the cylinder head
- Compressor casing with integrated exhaust pulsation absorber and electrically controlled circulation valve
- Turbine wheel resistant to temperatures up to 980 °C
- Bearing shell with oil and coolant supply lines
- Milled compressor wheel for better RPM stability and reduced noise

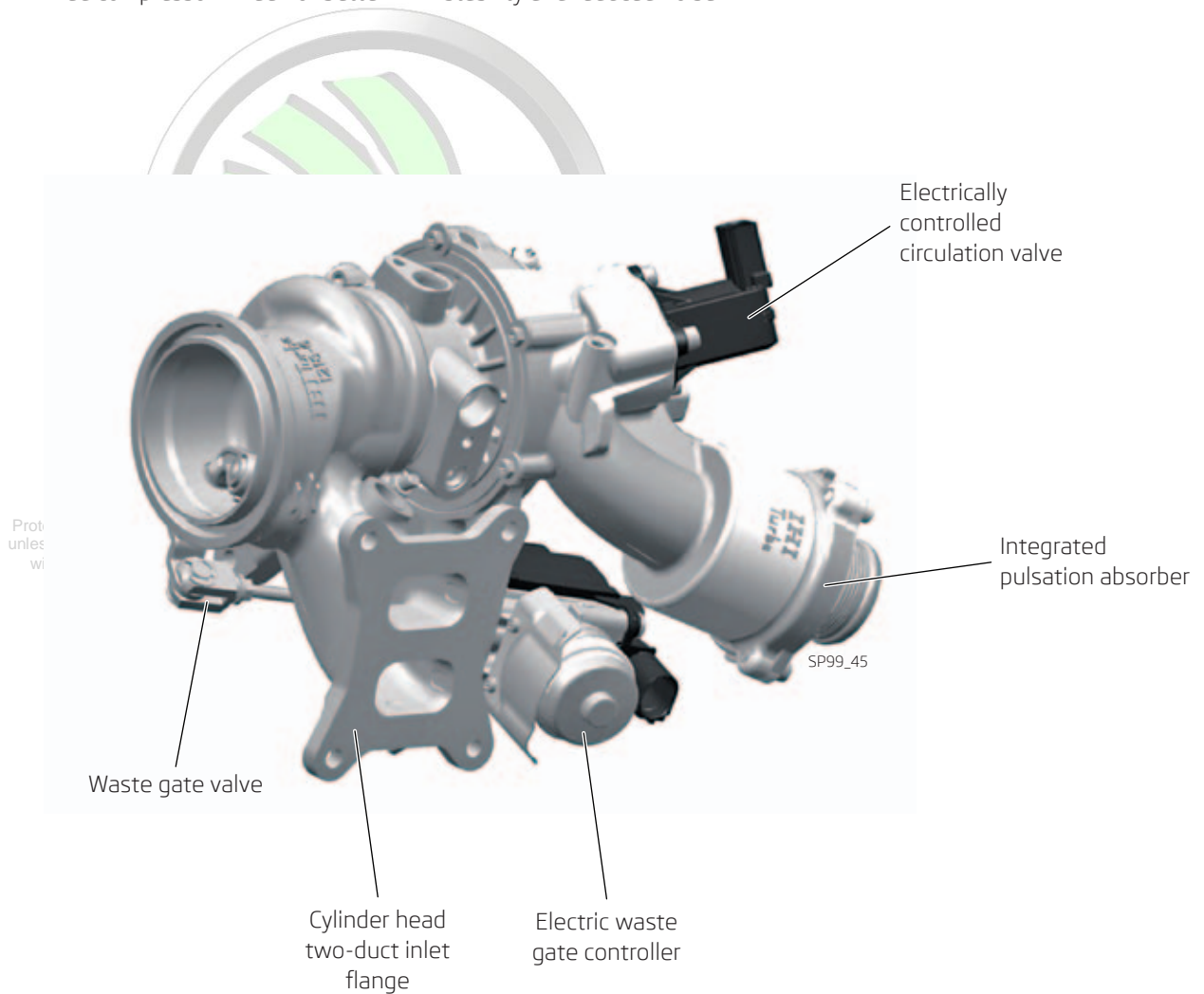

Turbocharger Internal Design

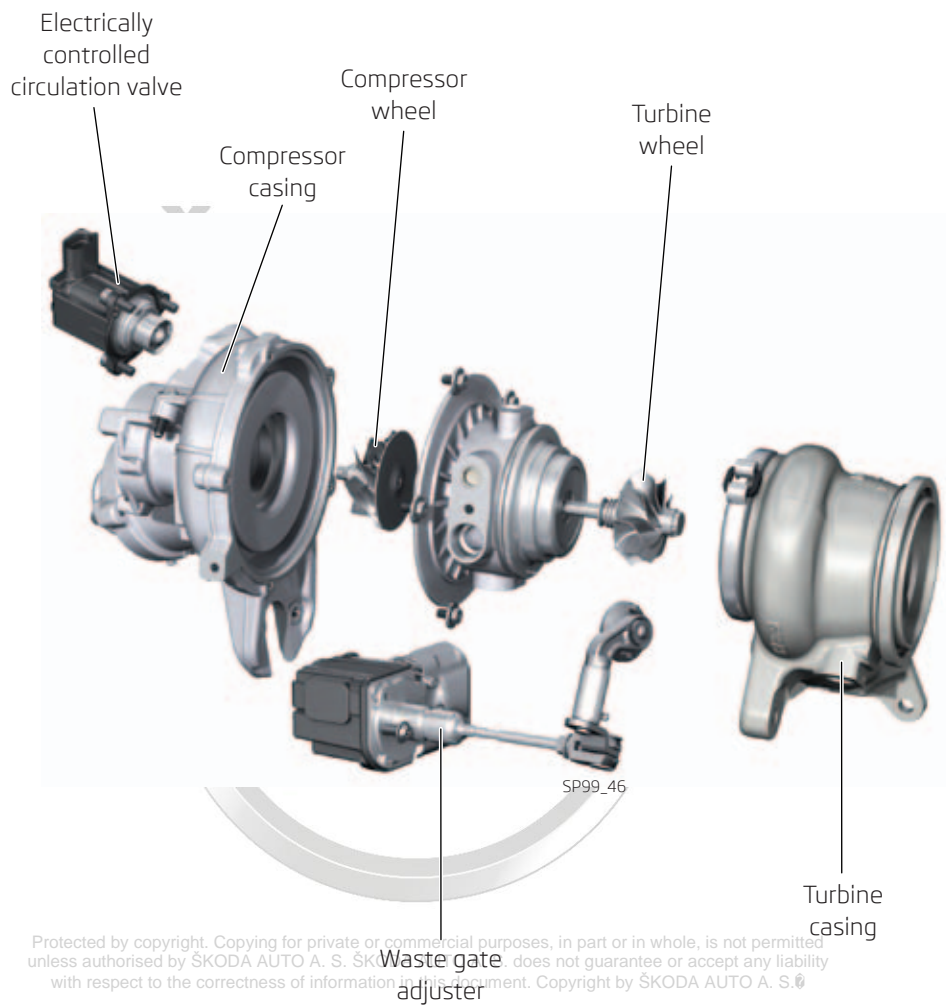

11. Crankcase Ventilation

SKODA

11.1 Crankcase Ventilation Principle

A small amount of gas leaks from the combustion chamber around the pistons into the crankcase. It is necessary to bring those gases back to the intake. In order to comply with applicable emission standards, before combusting this gas, it has to be perfectly freed of oil.

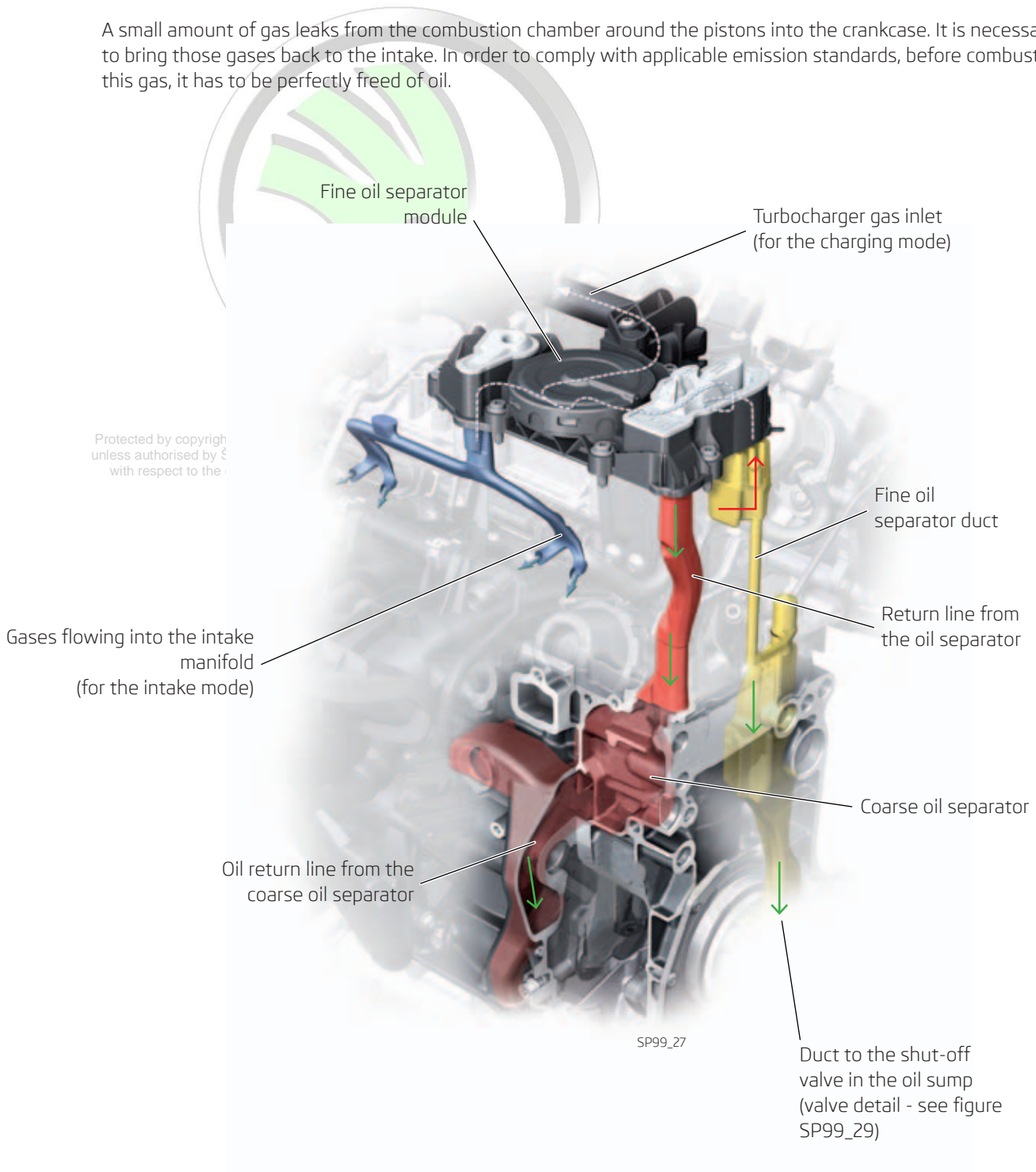

- Contaminated Polluted gas flow direction
- Separated oil streaming direction

11.2 Crankcase Ventilation System

The 1.8 TFSI engine features a crankcase venting system of a modern design. The designers strove to minimize the number of design components. All the components, except for the cleaned gas outlet piping, are integrated in the engine.

The system features the following components:

- Coarse oil separator integrated in the cylinder block
- Fine oil separator screwed into the cylinder head cover
- Cleaned gas outlet duct
- Contaminated gas duct out of the cylinder block, featuring a shut-off valve in the oil sump honeycomb insert



In the intake mode, the gas leaving the fine oil separator, proceeds to the intake manifold.

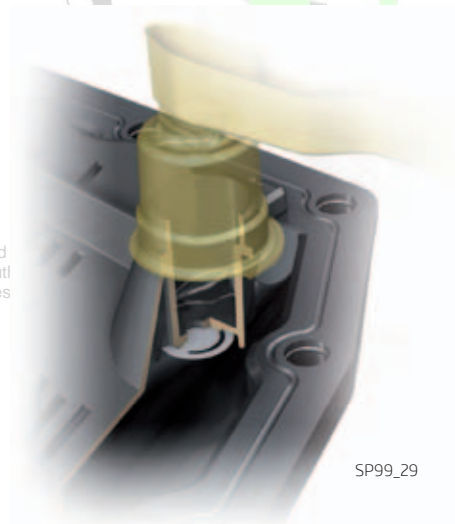

Protected
unless autl
with res

n part or in whole, is not permitted
not guarantee or accept any liability
yright by ŠKODA AUTO A. S. ©

The shut-off valve of the contaminated gas duct leading to the fine oil separator. The shut-off valve prevents the intake of oil from the oil sump into the piping, for example, during unfavourable pressure conditions.

11.3 Coarse Oil Separation

The coarse oil separator is based on a labyrinth, through which air with oil from the crankcase are exhausted. Due to the air direction changes in the labyrinth, oil particles separate, and proceed through the oil return line in the cylinder block back into the oil sump. The return line only ends under the oil sump oil surface.

11.4 Fine Oil Separation

Contaminated gases flow through the cylinder head into the fine oil separator. Then, they are first cleaned in the cyclonic separator. Separated oil proceeds from the fine oil separator through a separate line in the cylinder block back to the oil sump.

A single-stage pressure control valve brings the cleaned air back to the cylinders.

ŠKODA

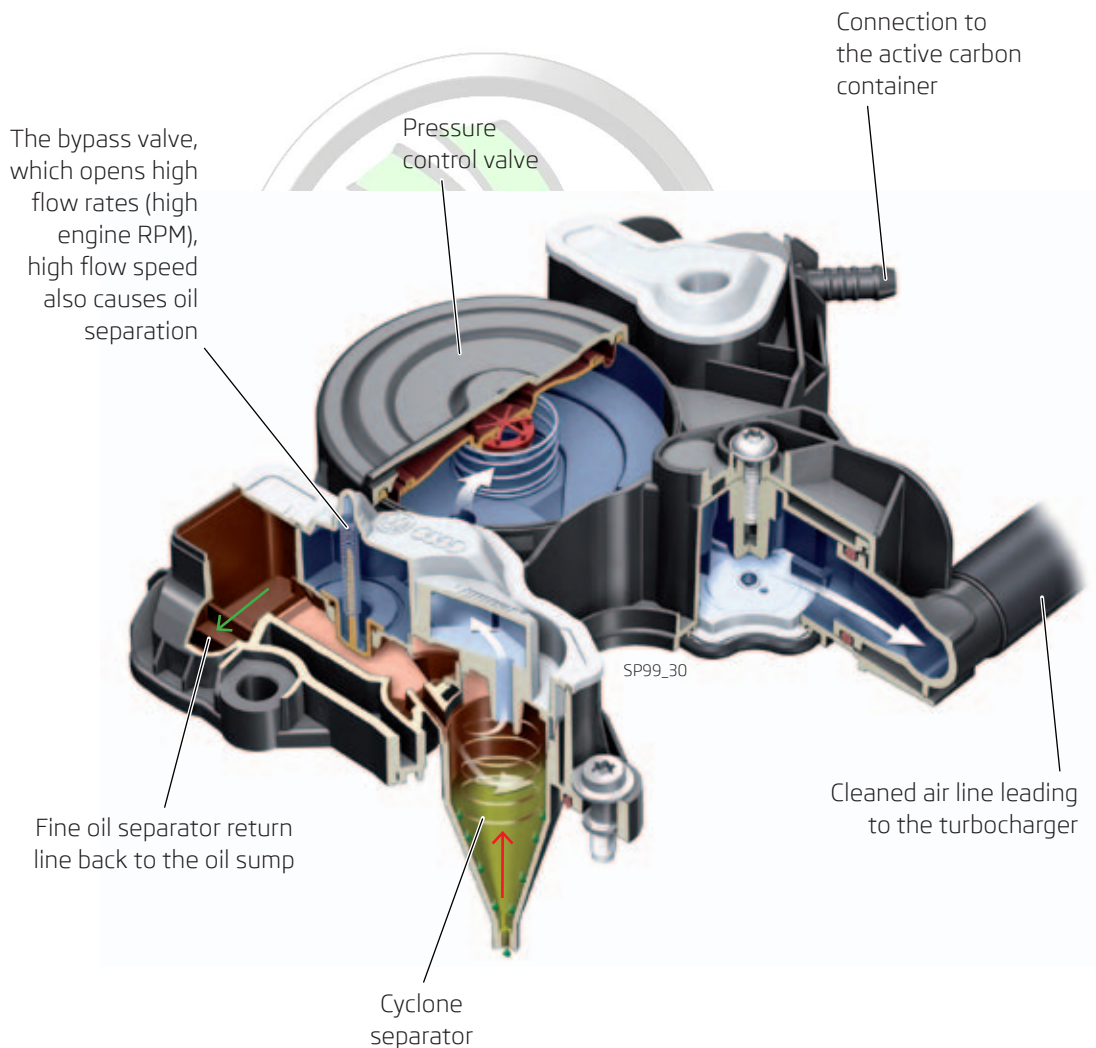

11.5 Supply of Cleaned Gases to the Combustion Chamber

Upon fine separation and passing through the pressure control valve, the cleaned air proceeds to the cylinders. Automatic check-valves integrated in the fine oil separator module provide automatic air flow regulation. Upon engine shutdown, the check-valves snap back into their basic positions. The check-valve is open in the exhaust gas turbocharger direction and closed in the intake duct direction.

Full Load Operation (Charge Mode)

Check-valve No. 1 (intake direction) will close when all the intake air path is pressurized. Check-valve No. 2 (turbocharger direction) will open due to the pressure differential between the crankcase inner pressure and the turbocharger inlet side pressure. The turbocharger sucks the cleaned air.

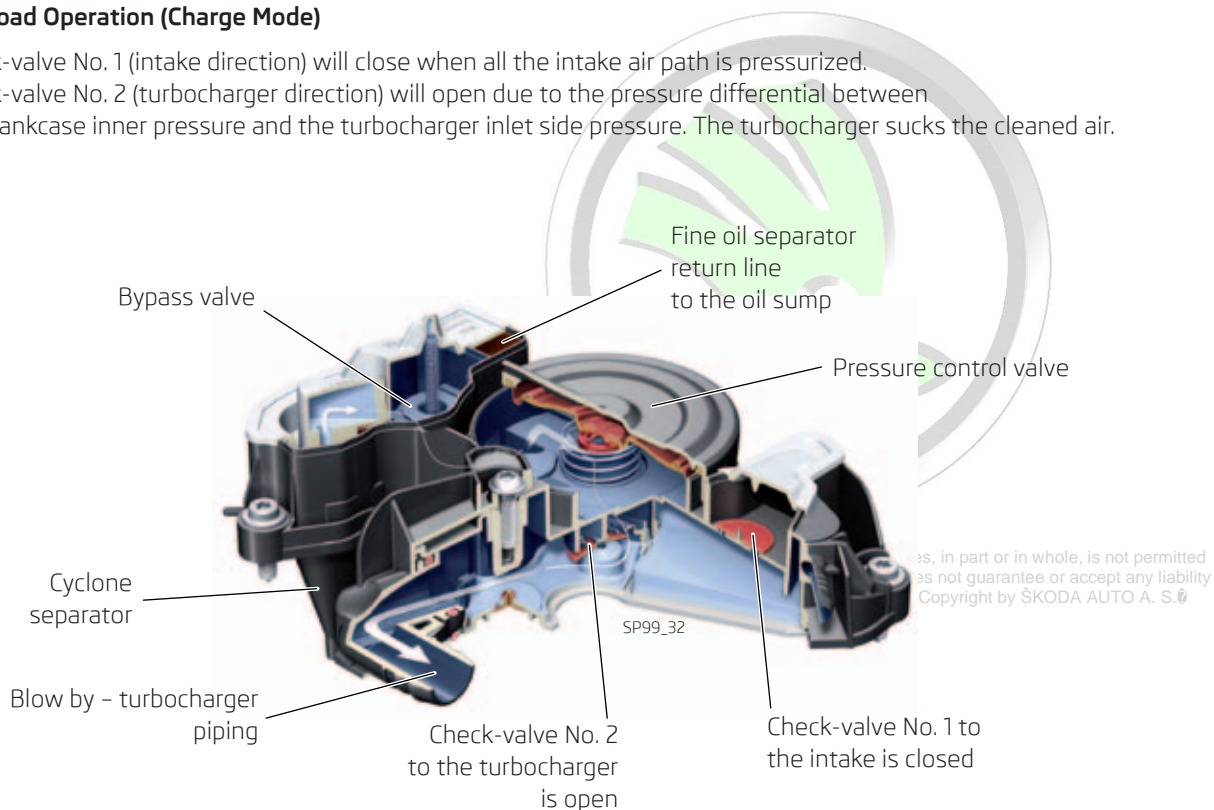

Idle and Partial Load Operation (Intake Mode)

In the intake mode, the vacuum in the intake duct will open check-valve No. 1 (to the intake) and the check-valve No. 2 (to the turbocharger) will close. The cleaned air is supplied directly above the intake duct for combustion.

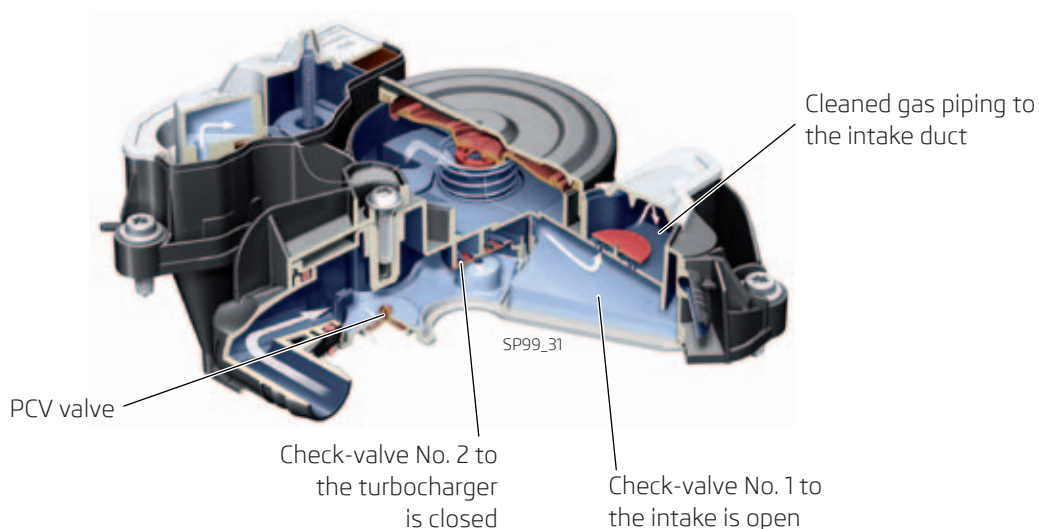

Crankcase Aeration through the PCV Valve

The crankcase aeration is installed in one module together with the fine oil separator and pressure regulation on the cylinder head cover.

The crankcase aeration is based on an aerating piping, which brings air from the area upstream of the turbocharger turbine. Air is sucked through a calibrated orifice towards the crankcase aeration valve. The system is only aerated during the intake mode.

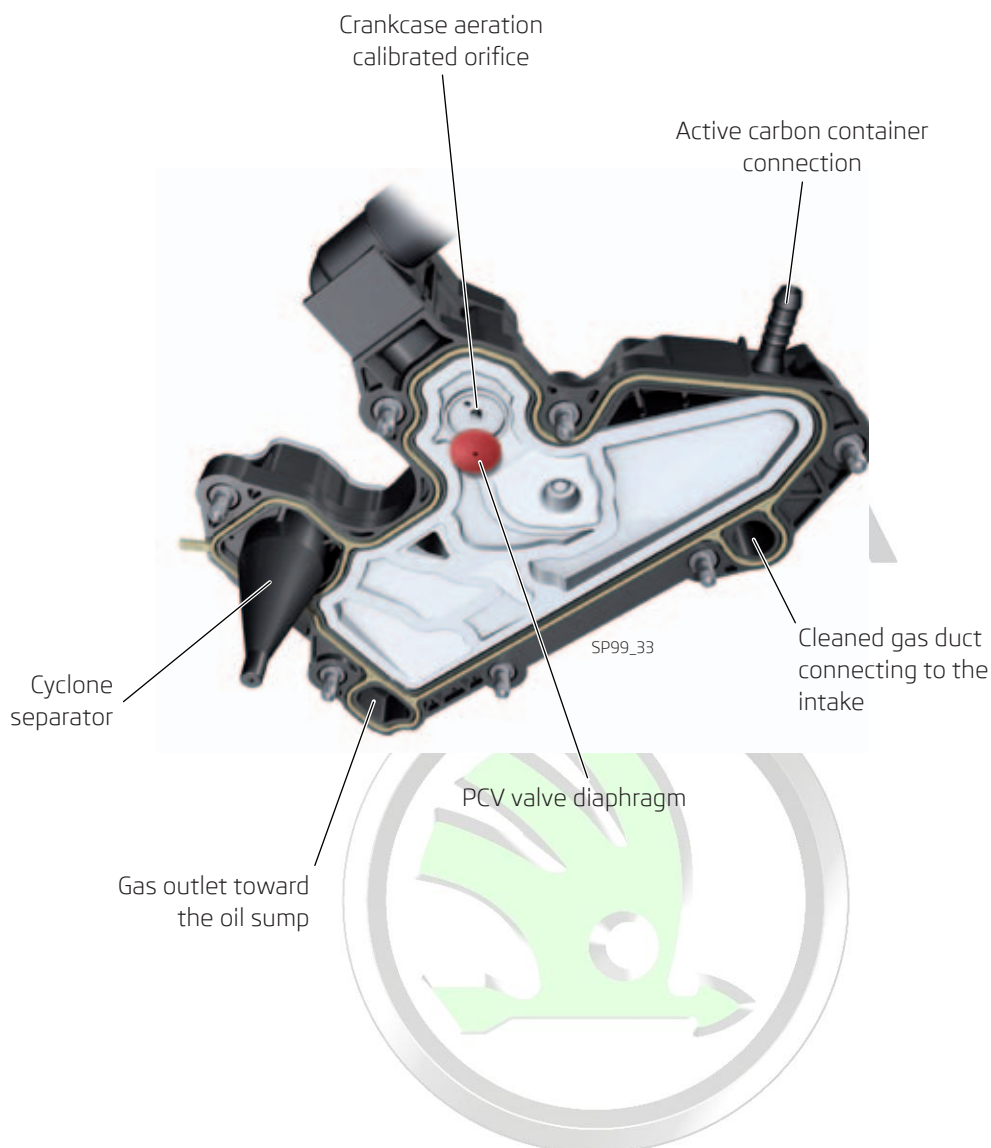

Protected by copyright. Copying for private or commercial purposes, in part or in whole, is not permitted unless authorised by ŠKODA AUTO A. S. ŠKODA AUTO A. S. does not guarantee or accept any liability with respect to the correctness of information in this document. Copyright by ŠKODA AUTO A. S.

12. Engine Lubrication

12.1 Lubrication System Changes

The following lubrication system changes reduced the new engine's friction and fuel consumption:

- Pressure duct optimization (pressure loss reduction)
- Expanded low pressure stage RPM interval
- Low pressure stage oil pressure reduction
- Switchable piston cooling circuit

The oil circuit is controlled by means of the three switches:

- Low-pressure oil switch
- High-pressure oil switch
- Cooling nozzle circuit oil switch

12.2 Holder of Auxiliary Aggregates with Oil Filter and Engine Oil Cooler

The holder of auxiliary aggregates holds the oil filter and engine oil cooler. The module also includes the low-pressure and high-pressure oil switches and the electric piston cooling nozzle selector valve. See figures SP99_47 and SP99_48.

Oil Filter

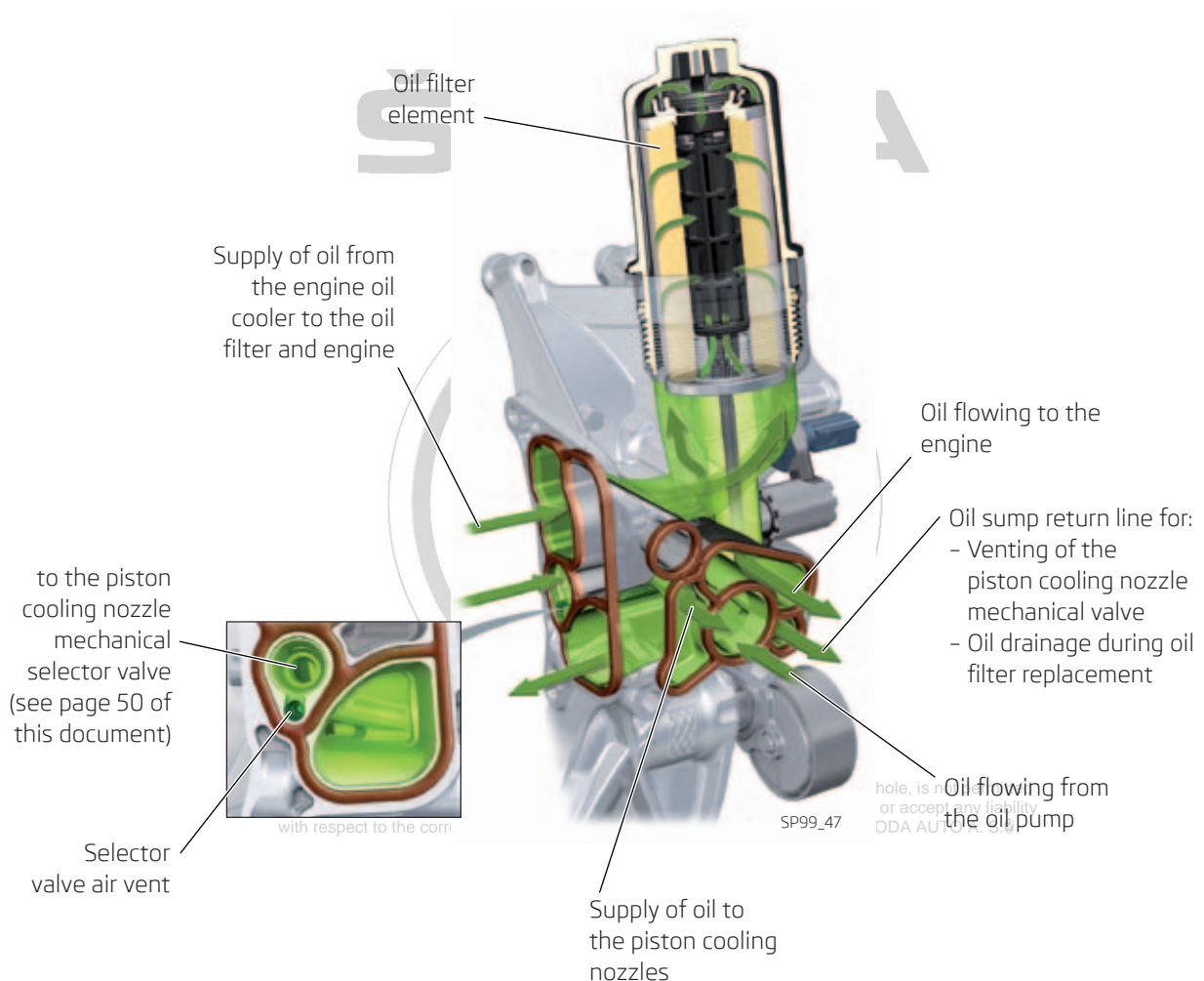

Engine-Oil Cooler

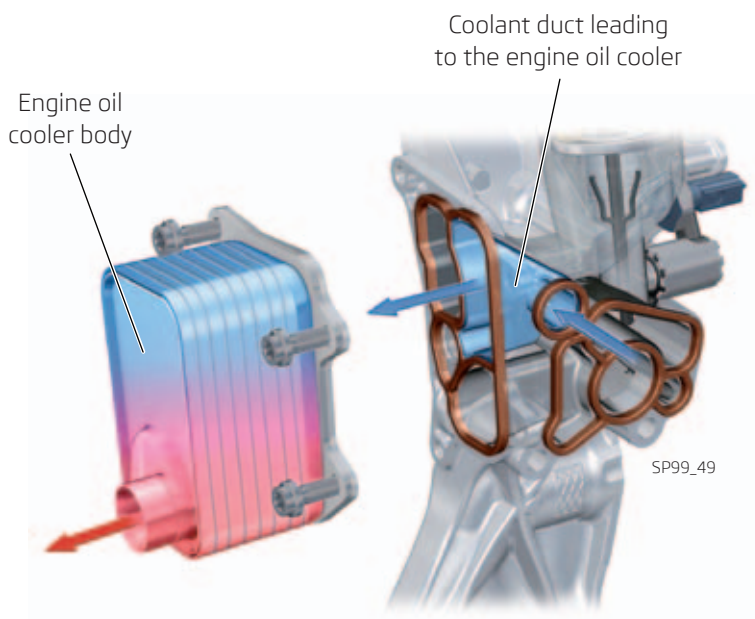

Locations of the low-pressure and high-pressure oil switches and electrically controlled piston cooling nozzle valve

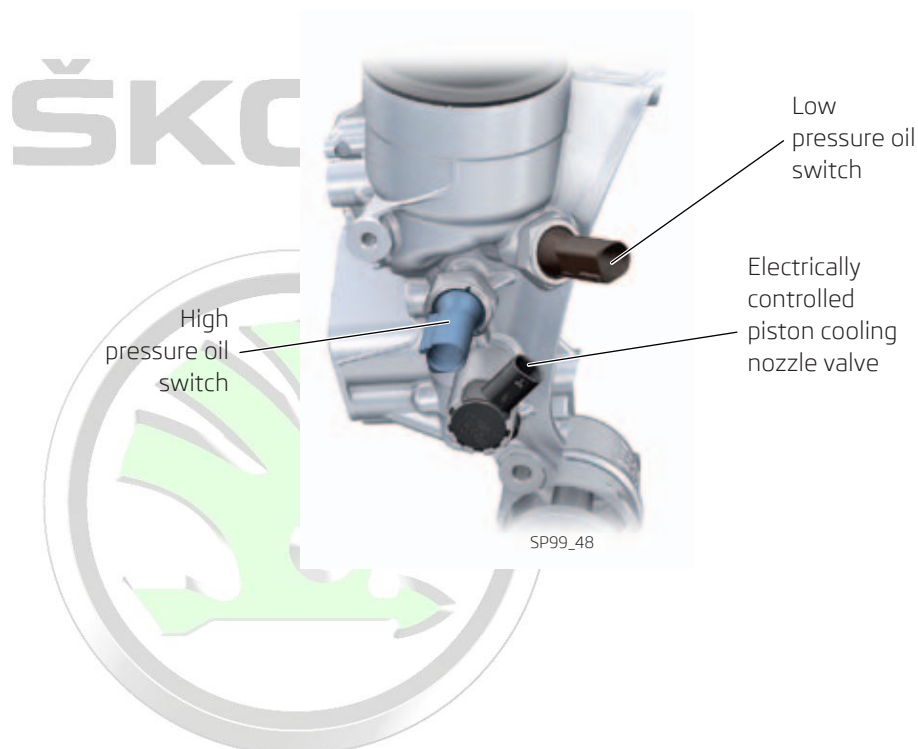

12.3 Engine Lubrication System

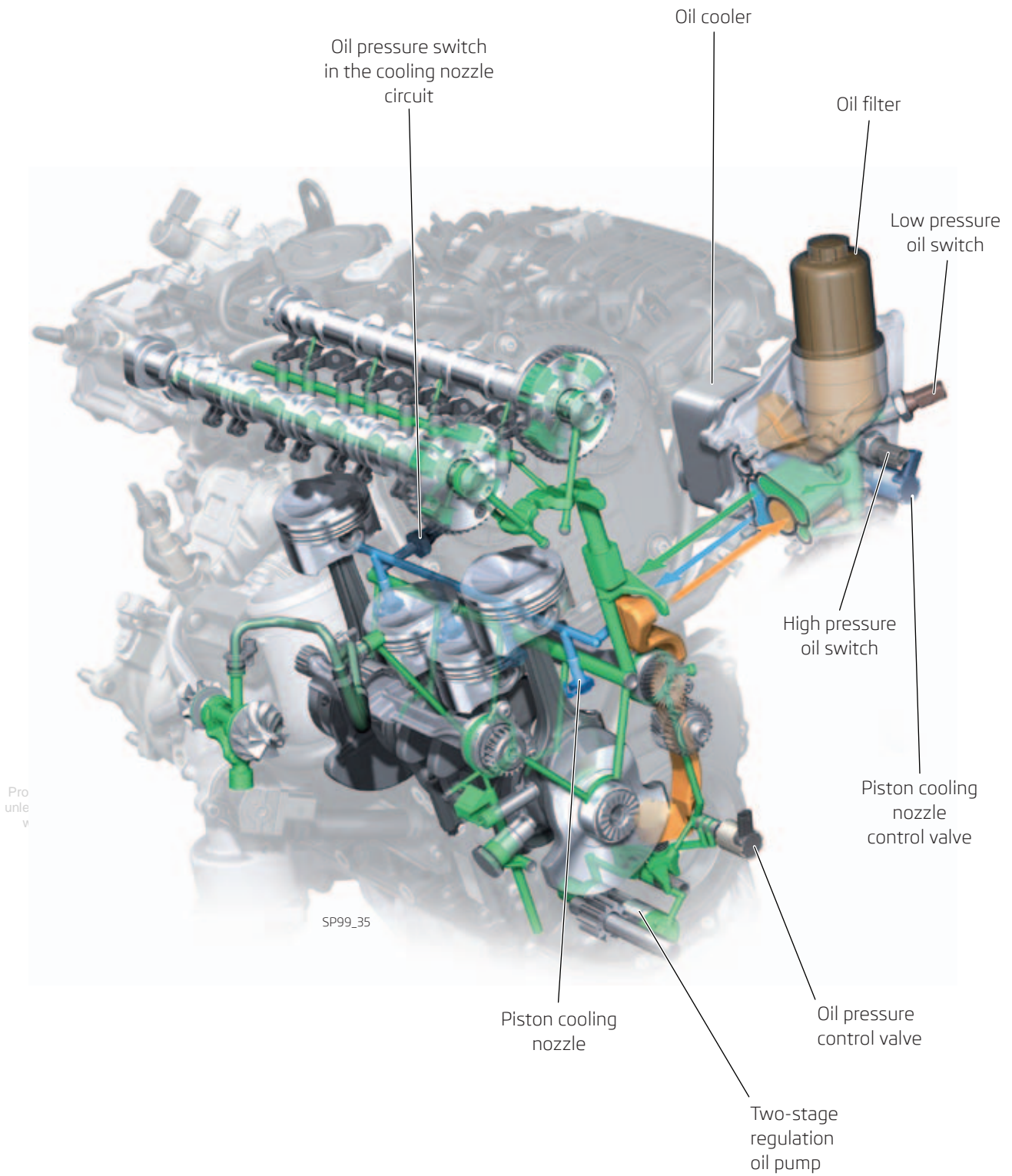

12.4 Two-Stage Regulation Oil Pump

The oil pump is based on the 2nd generation engine design. The oil pump's control mechanism maintains the reduced oil pressure of 1.2 - 2.1 bar within a wide RPM interval - up to 4,500 RPM⁻¹. The pressure is maintained by variation of oil flow rate. (At higher engine RPM - over 4,500 RPM⁻¹ oil pressure increases to about 3.5 - 4 bar.)

The new oil pump differs from its older version as follows:

- Modified pump gear. The pump runs slower now ($i = 0.96$).
- Improved hydraulic regulation mechanism inside the pump, which makes the oil system pressure regulation more accurate.

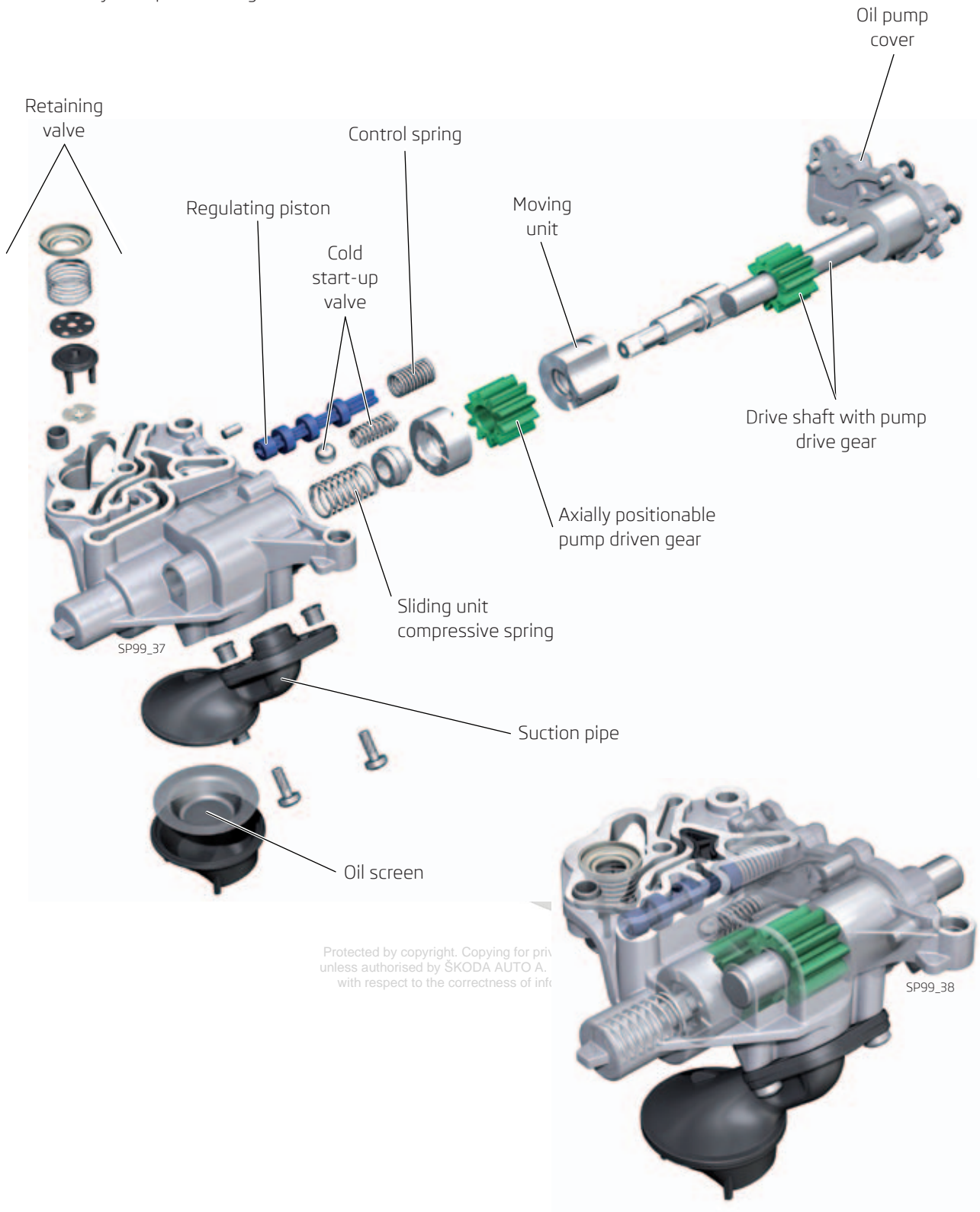

12.5 Oil Circuit Diagram

- Low-pressure circuit
- High-pressure circuit

- A Camshaft bearing
- B Supporting element
- C Balancing shaft bearing
- D Exhaust balancing shaft bearing
- E Connecting rod
- F Main bearing 1-5

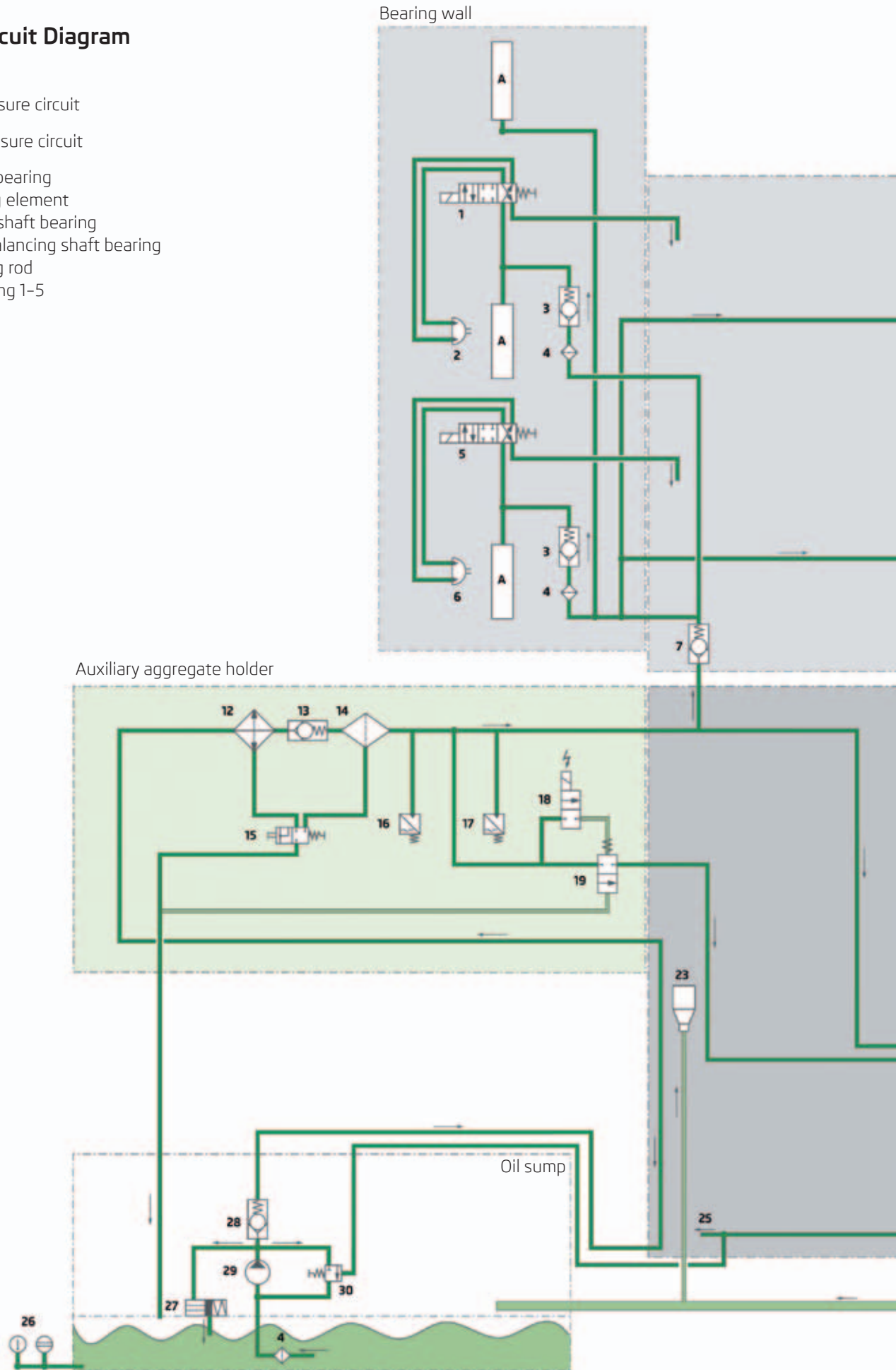

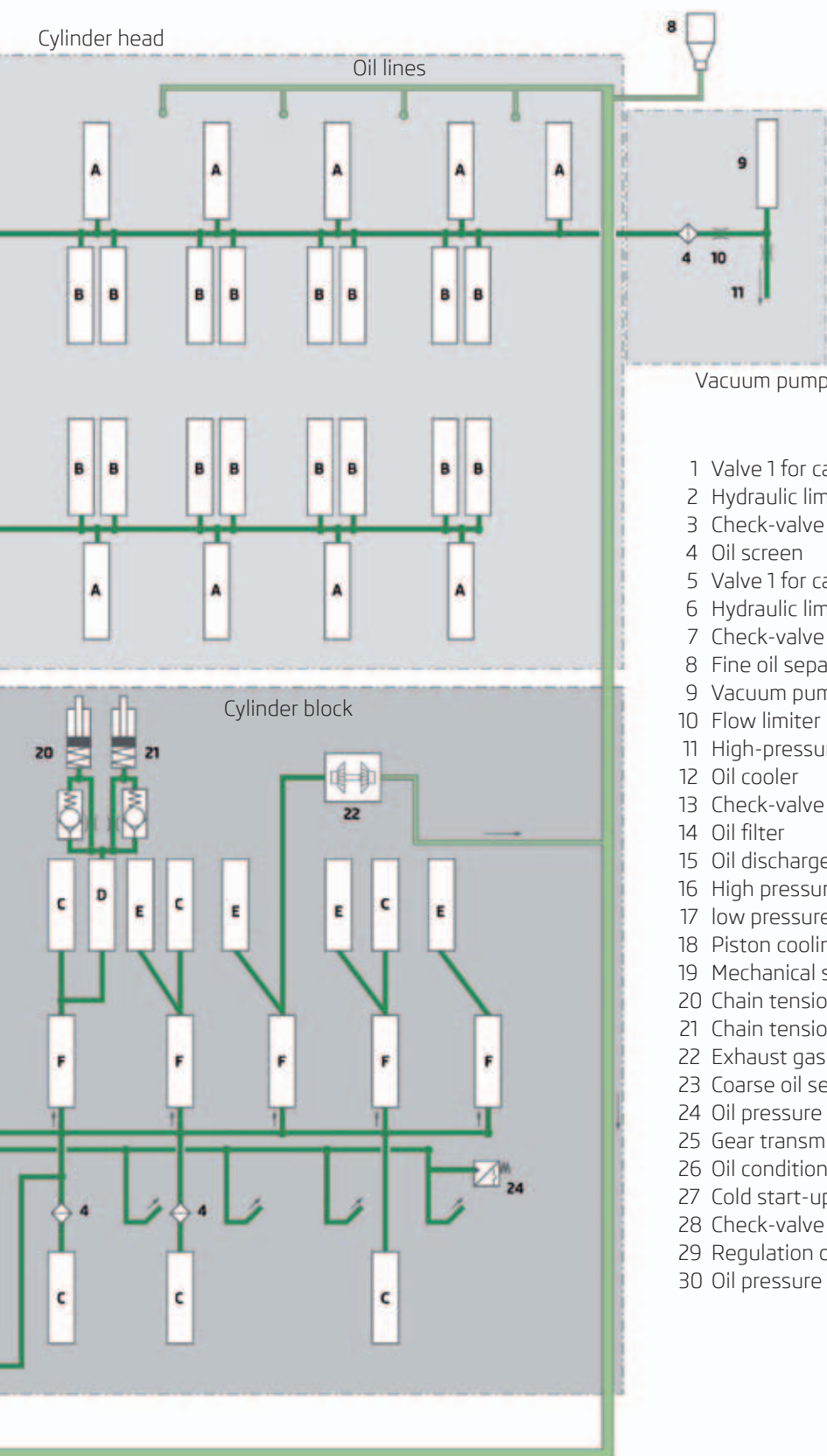

KODIAK

- 1 Valve 1 for camshaft adjusting (exhaust)
- 2 Hydraulic limiting component (exhaust)
- 3 Check-valve integrated into the bearing wall
- 4 Oil screen
- 5 Valve 1 for camshaft adjusting (suction)
- 6 Hydraulic limiting component (suction)
- 7 Check-valve integrated into the cylinder head
- 8 Fine oil separator
- 9 Vacuum pump
- 10 Flow limiter
- 11 High-pressure fuel pump cam lubrication
- 12 Oil cooler
- 13 Check-valve integrated into the oil filter
- 14 Oil filter
- 15 Oil discharge valve
- 16 High pressure oil switch
- 17 low pressure oil switch
- 18 Piston cooling nozzle control valve
- 19 Mechanical selector valve
- 20 Chain tensioner balancing shafts
- 21 Chain tensioner control drive
- 22 Exhaust gas turbocharger
- 23 Coarse oil separator
- 24 Oil pressure switch
- 25 Gear transmission lubrication
- 26 Oil condition and temperature sensor
- 27 Cold start-up valve
- 28 Check-valve integrated into the oil pump
- 29 Regulation oil pump
- 30 Oil pressure control valve

SP99_34

12.6 Piston Cooling Nozzles

The piston bottom does not have to be cooled in every operating situation. That is why the piston cooling nozzles get disconnected in a controlled way in order to reduce fuel consumption.

The piston nozzle cooling system features the following components:

- New piston cooling nozzles without valves with springs
- Oil pressure switch
- N522 pressure control valve for the piston cooling nozzles
- Mechanical selector valve

12.6.1 Operating Mode with Disconnected Cooling Nozzles

The piston cooling nozzles are controlled by the N522 control valve, which is actuated by the engine control unit. If the valve is powered, the N522 valve control oil line opens.

Compressed oil starts acting on the control valve on both of its sides. A spring, which is inside the mechanical valve, moves the piston and closes the cooling nozzle oil line.

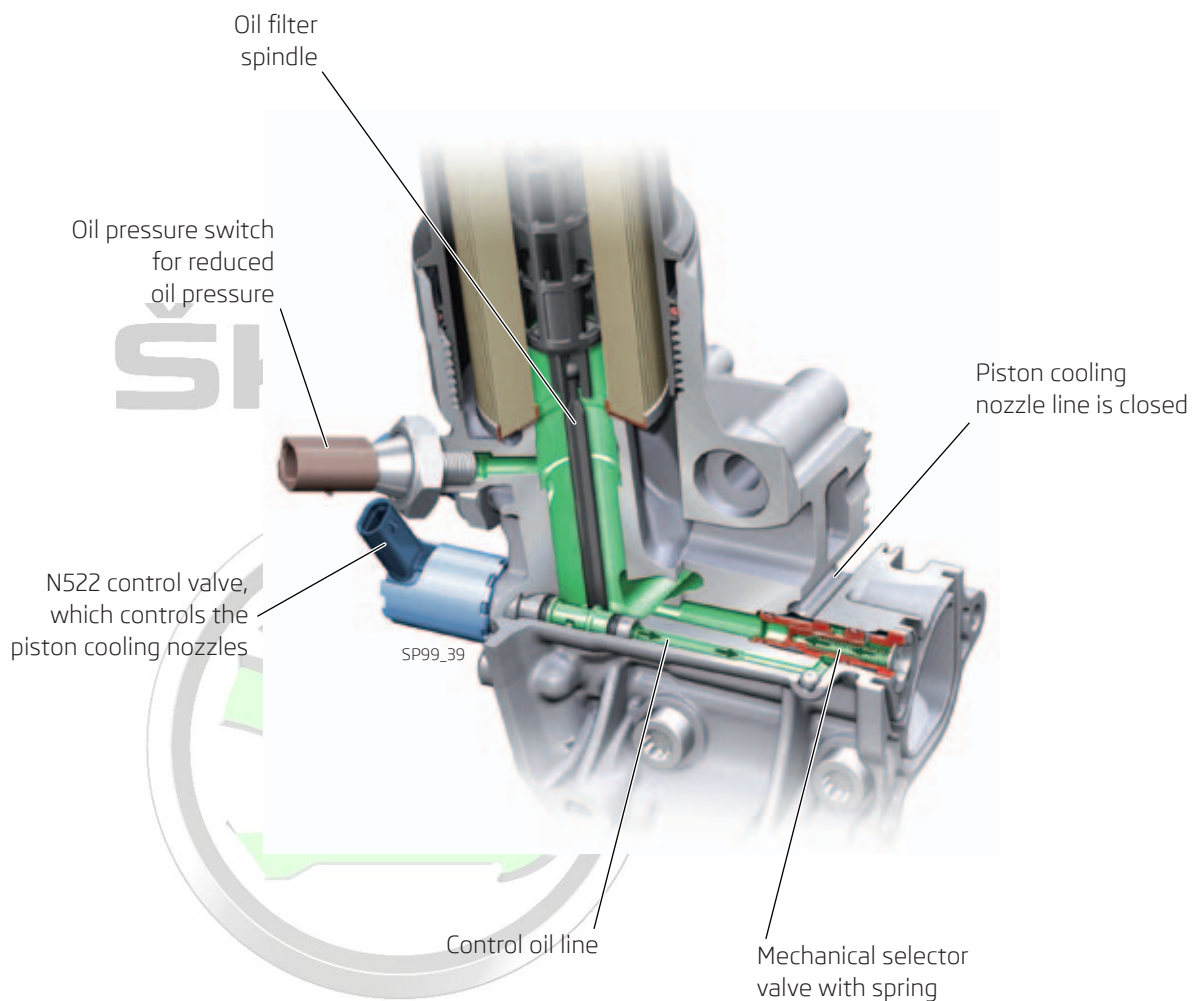

12.6.2 Operating Mode with Active Cooling Nozzles

If the engine control unit stops feeding the N522 control valve, oil pressure will start acting on one side of the mechanical selector valve. The mechanical valve piston will start moving. As a result, it will open the oil cooling nozzle line. The spring inside the mechanical valve is preloaded and assures the valve only opens the piston cooling nozzle oil line at the minimum pressure of 0.9 bar.

To move the mechanical valve to its default position in which the cooling nozzle line is open, the residual oil must leave the N522 valve control oil line as quickly as possible. A separate line connected to the oil sump drains that residual oil. The same line is used for drainage during oil filter changes.

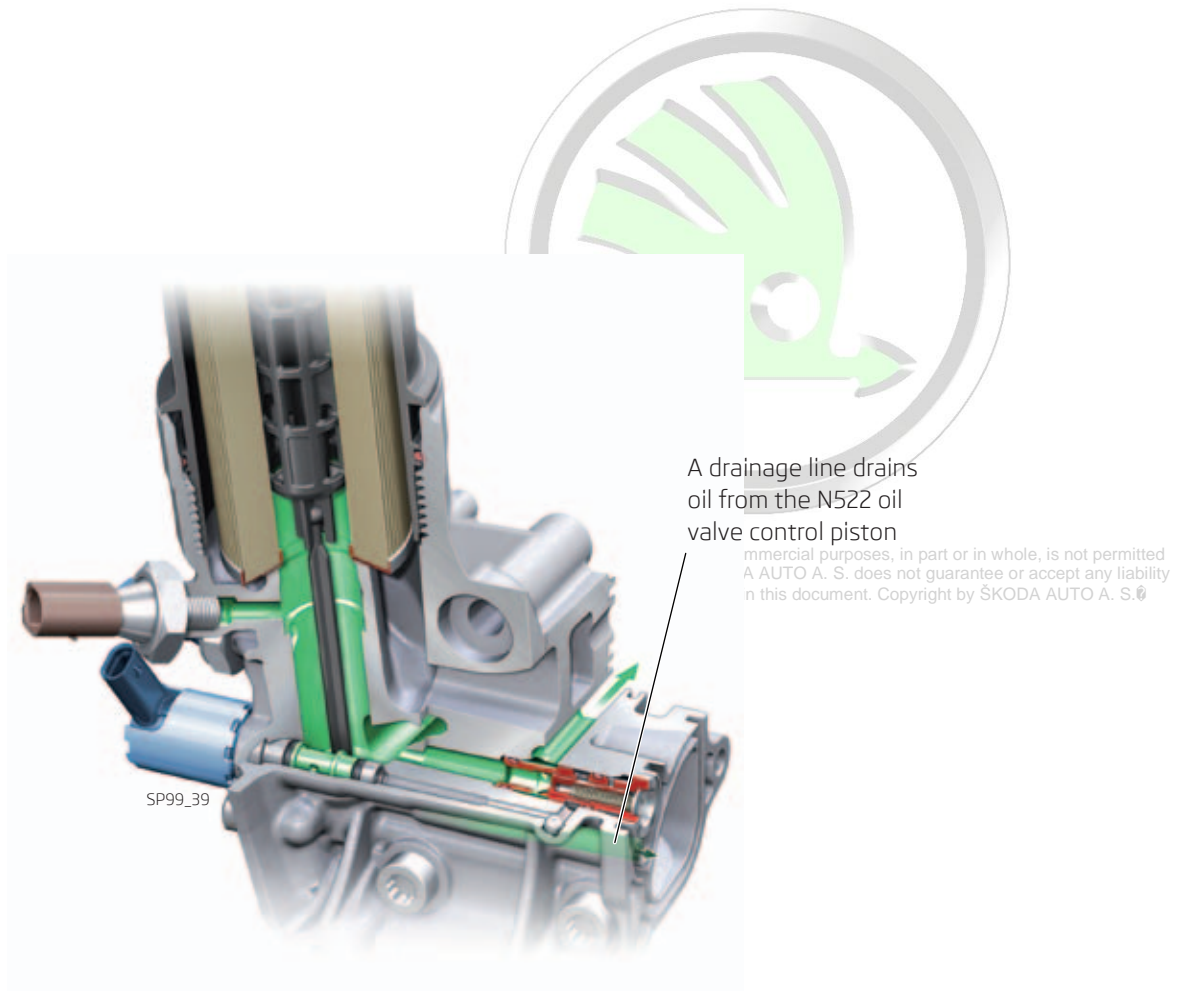

12.6.3 Piston Cooling Nozzles Operating Modes Chart

The piston cooling nozzles get only connected when needed. The engine control unit calculates when it is necessary to activate piston cooling. The piston cooling nozzles may operate in both low-pressure and high-pressure mode.

The variables of the cooling nozzle switch-on/switch-off calculation algorithm are as follows:

- Engine load
- Engine speed
- Oil temperature

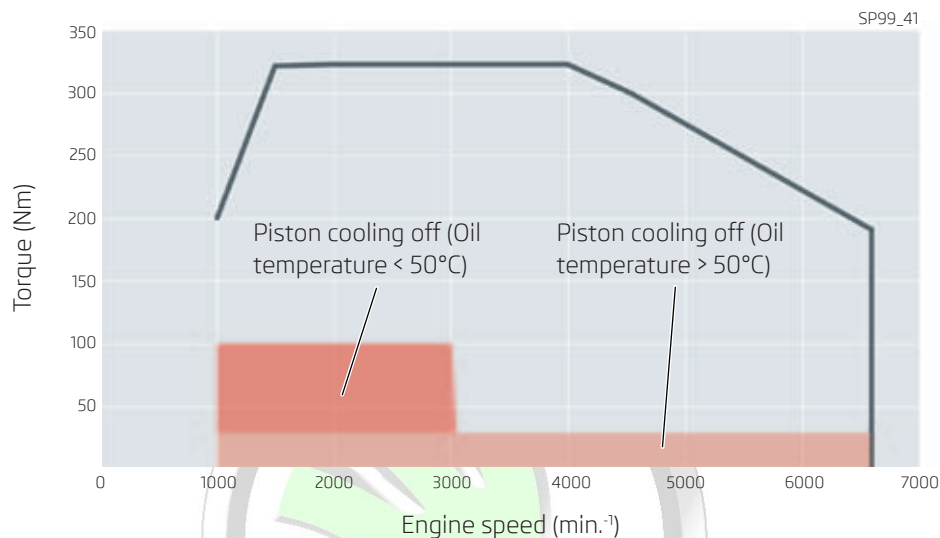

12.6.4 Piston Cooling Nozzle System Monitoring Functions

The F447 oil pressure sensor is located at the end of the piston cooling nozzle oils distribution installation, which is able to identify the following system defects:

- Compressed oil is not reaching the piston cooling nozzles when cooling is required
- Compressed oil is flowing in the oil installation when the piston cooling nozzles are to be off
- The oil pressure sensor has failed

The following electrical faults are diagnosable on the N522 piston cooling nozzle control valve:

- Interrupted valve power supply (piston cooling nozzles always on)
- Ground terminal short-circuit - short-circuit to the ground (piston cooling off)
- Positive terminal short-circuit (piston cooling always on)

In the case of faults that make the piston cooling system dysfunctional, the engine will switch to its emergency mode, and the following measures will be taken:

- The engine control unit limits the engine torque and RPM
- Low oil pressure level not utilized by the oil control pumps (high only)
- Indication on the instrument cluster (RPM limited to max. 4,000⁻¹)
- The EPC indicator on the instrument cluster is on
- Buzzer

13. 2.0 I TFSI 162 kW Engine

13.1 Engine Characteristics

Regarding its design, the 2.0 I TFSI 162 kW engine is identical to the 1.8 I TFSI 132 kW engine. Therefore, the principles described in this material for the 1.8 I apply to the 2.0 I engine as well.

The 2.0 I TFSI 162 kW engine primarily differs from the 1.8 I engine by the size of its internal structure (both of the engines feature the same external housing). To increase power, the following specific engine components have been modified:

- Engine block
- Crankshaft
- Turbocharger
- Balancing shafts
- Exhaust camshaft
- Exhaust valves
- High-pressure injection valves
- Throttles

13.2 Comparison of the 2.0 I TFSI 162 kW and 1.8 TFSI 132 kW Engines

Engine Block

The 2.0 I engine block, compared to the 1.8 I engine, features a bigger main bearing diameter. Both engines feature the same cylinder bore.



Crankshaft

The 2.0 I engine crankshaft enables a greater piston stroke (connecting rod length has been modified) and eight counter-weights.

Protecter
unless au
with re



r in whole, is not permitted
antee or accept any liability
y ŠKODA AUTO A. S.®

Engine	Bore	Stroke
1.8 I TFSI 132 kW	82.5 mm	84.2 mm
2.0 I TFSI 162 kW	82.5 mm	92.8 mm

Turbocharger

The 2.0 I features a more robust turbocharger with bigger compressor and turbine rotors.



SKODA

Balance Shafts

A more robust balancing shaft design has been applied.



commercial purposes, in part or in whole, is not permitted
SKODA AUTO A. S. does not guarantee or accept any liability
with respect to the correctness of information in this document. Copyright by ŠKODA AUTO A. S. ©

Exhaust Camshaft and Exhaust Valves

The exhaust camshaft timing has been adapted and the valve lift of 10 mm is used. The exhaust valves are hollow and bimetallic.



High-Pressure Injection Valves

The 2.0 l engine injection valves deliver higher flow rates.

Engine	High-pressure injection valve supply
1.8 l TFSI 132 kW	15 cm ³ /s
2.0 l TFSI 162 kW	17.5 cm ³ /s



DRUMBLE Throttles

The 1.8 l and 2.0 l engines feature the same intake manifold shapes. In order to comply with the specific intake requirement of the 2.0 l -engine, special design intake throttle valves (Drumble) are provided.



cial purposes, in part or in whole, is not permitted
 TO A. S. does not guarantee or accept any liability
 document. Copyright by ŠKODA AUTO A. S. ©



TUMBLE throttle,
 1.8 l TFSI
 132 kW engine



DRUMBLE throttle,
 2.0 l TFSI
 162 kW engine

13.3 Table of Engine Parameters

Engine Parameters	
Design	Ignition inline four-cylinder engine, two top-mounted camshafts (2xOHC) with chain drive, turbocharged engine intercooler, with combined fuel injection, mounted transversally at the front, liquid-cooled aggregate
Number of cylinders	4
Displacement	1984 cm ³
Bore	82.5 mm
Stroke	92.8 mm
Max. power	162 kW at 4200–6000 min ⁻¹
Max. torque	350 Nm at 1500–4000 ⁻¹
Compression ratio	9.6 : 1
Charging	Electronically controlled combined fuel injection
Intake valves technology	Continuous intake camshaft adjustment
Exhaust valves technology	Continuous exhaust camshaft adjustment, The AVS system – two-stage exhaust valve lift switching
Ignition	Electronic ignition with idle high voltage distribution
Lubrication	Of pressure circulating type with a full-flow oil filter
Fuel	Unleaded gasoline of min. oct. no. 95/91**
Emission standard	EU6

** When using gasoline of lower octane index, power may be reduced slightly.

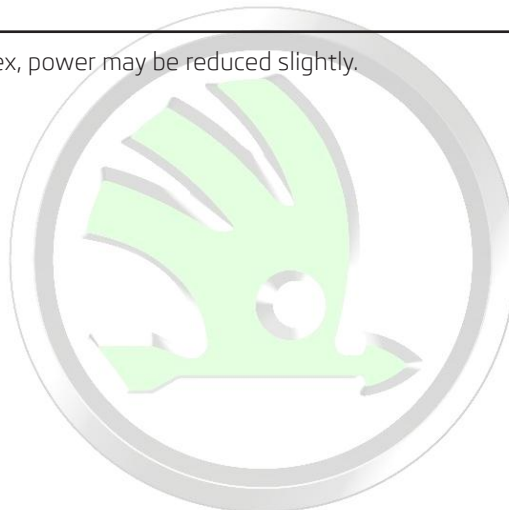

Protected by copyright. Copying for private or commercial purposes, in part or in whole, is not permitted unless authorised by ŠKODA AUTO A. S. ŠKODA AUTO A. S. does not guarantee or accept any liability with respect to the correctness of information in this document. Copyright by ŠKODA AUTO A. S. ©

13.4 Engine Power Chart

The 2.0 l TFSI engine delivers the maximum torque of 350 Nm at 1,500 - 4,000 RPM⁻¹, it offers the maximum power output of 162 kW at 4,200 - 6,000 RPM⁻¹.

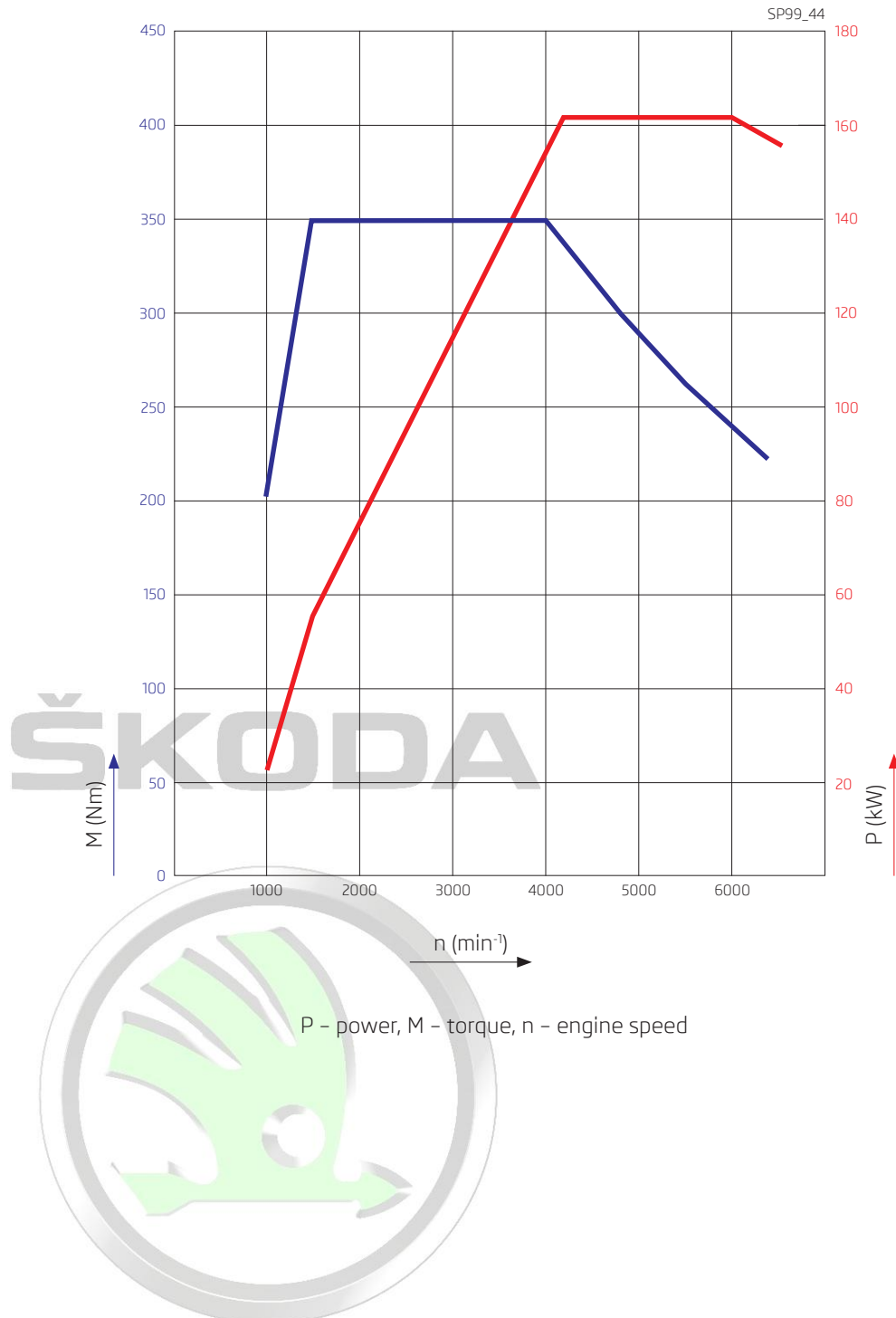

Remarks

ŠKODA



Protected by copyright. Copying for private or commercial purposes, in part or in whole, is not permitted unless authorised by ŠKODA AUTO A. S. ŠKODA AUTO A. S. does not guarantee or accept any liability with respect to the correctness of information in this document. Copyright by ŠKODA AUTO A. S. ©

ŠKODA



Protected by copyright. Copying for private or commercial purposes, in part or in whole, is not permitted unless authorised by ŠKODA AUTO A. S. ŠKODA AUTO A. S. does not guarantee or accept any liability with respect to the correctness of information in this document. Copyright by ŠKODA AUTO A. S. ©

Overview of Hitherto Issued Workshop Teaching Aids

No. Name

- 1 Mono-Motronic
- 2 Central Locking
- 3 Car Alarm Equipment
- 4 Work with Wiring Diagrams
- 5 ŠKODA FELICIA
- 6 ŠKODA Car Safety
- 7 ABS - Basics - not issued
- 8 ABS - FELICIA
- 9 Starting Protection Device with Transponder
- 10 Air Conditioning in Car
- 11 FELICIA Air Conditioning
- 12 1.6 - MPI 11V Engine
- 13 Four-Cylinder Compression Ignition Engine
- 14 Power Steering
- 15 ŠKODA OCTAVIA
- 16 1.9 I TDI Compression Ignition Engine
- 17 ŠKODA OCTAVIA Comfort Electronics System
- 18 ŠKODA OCTAVIA 02K, 02J Mech. Gearbox
- 19 1.6 I and 1.8 I Gasoline Engines
- 20 Automatic Gearbox - Basics
- 21 01M Automatic Gearbox
- 22 1.9 I/50 kW SDI, 1.9 I/81 kW TDI Compression Ignition Engines
- 23 1.8 I/110 kW and 1.8 I/92 kW Gasoline Engines
- 24 OCTAVIA, CAN-BUS Data Bus
- 25 OCTAVIA - CLIMATRONIC
- 26 OCTAVIA - Vehicle Safety
- 27 OCTAVIA - 1.4 I/44 kW Engine and 002 Gearbox
- 28 OCTAVIA - ESP - Basics, Design, Function
- 29 OCTAVIA 4 x 4 - All-Wheel Drive
- 30 2.0 I 85 kW and 88 kW Gasoline Engines
- 31 Radio Navigation System - Design and Function
- 32 ŠKODA FABIA - Technical Information
- 33 ŠKODA FABIA - Electrical Devices
- 34 ŠKODA FABIA - Electrohydraulic Power Steering
- 35 1.4 I - 16 V 55/74 kW Gasoline Engines
- 36 ŠKODA FABIA - 1.9 I TDI Pump-Nozzle
- 37 02T and 002 Mechanical Gearbox
- 38 ŠKODA Octavia; Model 2001
- 39 Euro-On-Board-Diagnose
- 40 001 Automatic Gearbox
- 41 02M Six-Speed Gearbox
- 42 ŠKODAFabia - ESP
- 43 Emissions in Exhaust Gases
- 44 Extended Service Intervals
- 45 1.2 I Three-Cylinder Spark-Ignition Engines
- 46 ŠKODASuperb; Presentation of the Vehicle, Part I
- 47 ŠKODASuperb; Presentation of the Vehicle, Part II
- 48 ŠKODASuperb; V6 2.8 I/142 kW Spark-Ignition Engine
- 49 ŠKODASuperb; V6 2.5 I/114 kW TDI Compression Ignition Engine
- 50 ŠKODASuperb; 01V Automatic Gearbox
- 51 2.0 I/85 kW Spark-Ignition Engine with Balancing Shafts and 2-Stage Intake Pipe
- 52 ŠKODAFabia; 1.4 I TDI Engine with Pump-Nozzle Injection System

No. Name

- 53 ŠKODAOctavia; Presentation of the Vehicle
- 54 ŠKODAOctavia; Electrical Components
- 55 FSI Spark-Ignition Engines; 2.0 I/110 kW and 1.6 I/85 kW
- 56 DSG-02E Automatic Gearbox
- 57 Compression Ignition Engine; 2.0 I/103 kW TDI with Pump-Nozzle Units, 2.0 I/100 kW TDI with Pump-Nozzle Units
- 58 ŠKODAOctavia, Chassis and Electromechanical Power Steering
- 59 ŠKODAOctavia RS, Engine 2.0 I/147 kW FSI Turbo
- 60 2.0 I/103 kW 2V TDI Compression Ignition Engine; Diesel Particulate Filter with Additive
- 61 Radio Navigation Systems in ŠKODA Cars
- 62 ŠKODARoomster; Presentation of the Vehicle, Part I
- 63 ŠKODARoomster; Presentation of the Vehicle, Part II
- 64 ŠKODAFabia II; Presentation of the Vehicle
- 65 ŠKODASuperb II; Presentation of the Vehicle, Part I
- 66 ŠKODASuperb II; Presentation of the Vehicle, Part II
- 67 Compression Ignition Engine; 2.0 I/125 kW TDI with Common Rail Injection System
- 68 1.4 I/92 kW TSI Spark-Ignition Engine, Turbo Charged
- 69 3.6 I/191 kW FSI Spark-Ignition Engine
- 70 All-Wheel Drive with Generation IV Haldex Clutch
- 71 ŠKODAYeti; Presentation of the Vehicle, Part I
- 72 ŠKODAYeti; Presentation of the Vehicle, Part II
- 73 LPG System in ŠKODA Cars
- 74 1.2 I/77 kW TSI Spark-Ignition Engine, Turbo Charged
- 75 7-Speed Automatically Controlled Gearbox with OAM Double Clutch
- 76 Green-Line Cars
- 77 Geometry
- 78 Passive Safety
- 79 Independent Heating
- 80 Compression Ignition Engines 2.0 I; 1.6 I; 1.2 I with Common Rail Fuel Injection System
- 81 Bluetooth in ŠKODA Cars
- 82 Motor Vehicle Sensors - Drivetrain
- 83 1.4 I/132 kW TSI Spark-Ignition Engine, Double Supercharged (Compressor, Turboblower)
- 84 ŠKODAFabia II RS; Presentation of the Vehicle
- 85 KESSY System in ŠKODA Cars
- 86 START-STOP System in ŠKODA Cars
- 87 Immobilizers in ŠKODA Cars
- 88 Brake and Stabilization Systems
- 89 Sensors in ŠKODA Cars - Safety and Comfort
- 90 Customer Satisfaction Enhancement through CSS Study
- 91 ŠKODA Car Wiring Repairs
- 92 ŠKODA Citigo - Presentation of the Vehicle
- 93 Five-Speed DCF Mechanical Gearbox and ASG Automated Five-Speed Gearbox
- 94 OAM and 02E Automatic Gearbox Diagnostics
- 95 ŠKODA Rapid - Presentation of the Vehicle
- 96 ŠKODA Octavia III - Presentation of the Vehicle - Part I
- 97 ŠKODA Octavia III - Presentation of the Vehicle - Part II
- 98 ŠKODA Octavia III - Electronic systems
- 99 Engines 1.8 I TFSI 132 kW and 2.0 I TFSI 162 kW - EA888