

Workshop Manual

Octavia II 2004 ➤

Octavia II 2010 ➤

Electrical system

Edition 12.2013



Protected by copyright. Copying for private or commercial purposes, in part or in whole, is not permitted unless authorised by ŠKODA AUTO A. S. ŠKODA AUTO A. S. does not guarantee or accept any liability with respect to the correctness of information in this document. Copyright by ŠKODA AUTO A. S. ©

List of Workshop Manual Repair Groups

Repair Group

- 27 - Starter, current supply, CCS
- 90 - Gauges, instruments
- 91 - Radio, telephone, navigation
- 92 - Windscreen wash/wipe system
- 94 - Lights, bulbs, switches - exterior
- 96 - Lights, bulbs, switches - interior
- 97 - Wiring

ŠKODA



Protected by copyright. Copying for private or commercial purposes, in part or in whole, is not permitted unless authorised by ŠKODA AUTO A. S. ŠKODA AUTO A. S. does not guarantee or accept any liability with respect to the correctness of information in this document. Copyright by ŠKODA AUTO A. S.®

Technical information should always be available to the foremen and mechanics, because their careful and constant adherence to the instructions is essential to ensure vehicle road-worthiness and safety. In addition, the normal basic safety precautions for working on motor vehicles must, as a matter of course, be observed.

All rights reserved.
No reproduction without prior agreement from publisher.



Contents

27 - Starter, current supply, CCS	1
1 Contact corrosion	1
2 Battery	2
2.1 Basics	2
2.2 Warning instructions and safety precautions when working on the battery	2
2.3 Work sequence when disconnecting and connecting the battery	2
2.4 Checking battery	5
2.5 Charging battery	5
2.6 Removing and installing battery	5
2.7 Removing and installing the battery tray in the engine compartment	6
2.8 Battery parameterisation	7
3 Battery types	8
3.1 Battery with a magic eye	8
3.2 Fleece battery (AGM battery)	8
4 Starter	9
4.1 Removing and installing starter	9
5 Alternator	11
5.1 Checking generator	11
5.2 Removing and installing alternator	11
5.3 Fixing the B+ wire to the AC generator	13
5.4 Checking the carbon brushes of the AC generator	13
5.5 Removing and installing the Bosch voltage regulator	14
5.6 Removing and installing the Valeo voltage regulator	14
5.7 Removing and installing V-ribbed belt pulley on alternator	15
5.8 Removing and installing the V-ribbed belt pulley with free wheel	15
6 Removing and installing the cruise control (CC)	16
7 "Start-stop" system	17
7.1 Safety precautions for vehicles with "start-stop" system	17
7.2 General description	17
7.3 Fault recognition and fault display	18
7.4 Battery recharging or starting by external source on vehicles with "start-stop system"	18
7.5 Replacing the battery on vehicles with "start-stop" system	18
7.6 Voltage stabiliser J532	19
7.7 Battery monitor control unit J367	19
7.8 Button for "start-stop" system	20
90 - Gauges, instruments	21
1 Dash panel insert	21
1.1 Adjust/replace dash panel insert	22
1.2 Removing and installing the dash panel insert	22
1.3 Relacing shield with transparent washer	24
1.4 Warning light symbols in dash panel insert - vehicles up to MY 08	25
1.5 Warning light symbols in dash panel insert - vehicles as of MY 09	26
1.6 Service interval display	27
2 The self-diagnostic function of the dash panel insert	29
91 - Radio, telephone, navigation	30
1 Radio	30
1.1 General Instructions	30
1.2 Electronic anti-theft coding	30
1.3 Overview of radio system	31
1.4 Plug connections on the radio	32



1.5	Removing and installing a radio	33
1.6	Self-diagnostic function of radio system	39
2	Aerial systems	40
2.1	Overview of the aerial systems	40
2.2	Removing and installing aerial module R108	41
2.3	Roof aerial for radio	42
2.4	Roof aerial for operating the radio and mobile phone	43
2.5	Roof aerial for radio, telephone and navigation system - vehicles up to MY 08	44
2.6	Roof aerial for radio, telephone and navigation system - vehicles as of MY 09	44
3	Navigation system	47
3.1	General description	47
3.2	General Instructions	48
3.3	Electronic anti-theft coding	48
3.4	Overall view of the navigation system	49
3.5	Plug connections on the navigation system	50
3.6	Removing and installing the navigation system	52
3.7	Self-diagnosis of the navigation system	53
4	Telephone system	54
4.1	General Instructions	54
4.2	Basic mobile phone pre-installation	55
4.3	Universal mobile phone pre-installation with voice control GSM II	55
4.4	Universal mobile phone pre-installation with voice control GSM III	56
4.5	Summary of components, removing and installing the mount for the mobile phone	56
4.6	Removing and installing the control unit for the mobile phone operating electronics J412 (vehicles up to CW 44/08)	58
4.7	Removing and installing the control unit for the mobile phone operating electronics J412 (vehicles as of CW 45/08)	59
4.8	Removing and installing the microphone for the telephone R38	60
5	Multi-functional steering wheel	61
5.1	Multifunctional steering wheel- vehicles up to MY 08	61
5.2	Multifunctional steering wheel- vehicles as of MY 09	63
5.3	Self-diagnosis of the multi-functional steering wheel	65
6	Sound system	66
6.1	General Instructions	66
6.2	General description	66
6.3	Overall view of the equipment Soundsystem	66
6.4	Removing and installing amplifier R12 (up to MY 08)	68
6.5	Removing and installing amplifier R12 (vehicles as of MY 09)	68
6.6	Contact assignment at the amplifier - vehicles up to MY 08	70
6.7	Contact assignment at the amplifier - vehicles as of MY 09	72
6.8	Self-diagnosis of the equipment Soundsystem	73
7	Loudspeaker system	74
7.1	Removing and installing loudspeakers	74
8	CD changer	77
8.1	Removing and installing CD changer	77
8.2	Contact assignment on the CD changer	78
9	Connection for external audio sources R199 (AUX)	79
9.1	Removing and installing connection for external audio sources R199 (AUX)	79
10	Connection for external audio sources MEDIA-IN (multimedia socket)	80
10.1	Removing and installing connector socket for external audio sources (multimedia socket)	80
10.2	Removing and installing multimedia socket control unit	80
92 -	Windscreen wash/wipe system	82
1	Windscreen washer system	82



1.1	Remove and install reservoir, pumps and sensor for washer fluid level	82
1.2	Removing and installing the spray nozzles for windscreen washer system	83
1.3	Removing and installing rear window spray nozzle Octavia	84
1.4	Removing and installing rear window spray nozzle Octavia Combi	84
1.5	Adjusting spray jet	84
1.6	Repairing washer fluid lines	84
2	Windscreen Wiper and Washer System	85
2.1	Windscreen wiper and washer system	85
2.2	Removing and installing rear window wiper	89
2.3	Removing and installing Sensor for rain and light detection G397	92
3	Headlamp cleaning system	94
3.1	Removing and installing headlight cleaning system pump V11	94
3.2	Removing and installing the lift cylinder for spray nozzles of headlights - vehicles up to MY 08	94
3.3	Removing and installing spray nozzle holder - vehicles as of MY 09	95
3.4	Removing and installing the lift cylinder for spray nozzles of headlights - vehicles as of MY 09	96
3.5	Bleed the headlamp cleaning system	96
94	Lights, bulbs, switches - exterior	97
1	Headlights – halogen headlights	97
1.1	Summary of components headlights - vehicles up to MY 08 and Octavia Tour	97
1.2	Summary of components of headlights - vehicles as of MY 09 (except Octavia Tour)	98
1.3	Removing and installing headlight	99
1.4	Setting the headlight beam	99
1.5	Replacing light bulbs in the headlight - vehicles up to MY 08 and Octavia Tour	100
1.6	Replacing light bulbs in the headlight - vehicles as of MY 09 (except Octavia Tour)	102
1.7	Change headlight for right-hand / left-hand traffic	104
2	Headlights with Xenon discharge lamps	108
2.1	Fault recognition and fault display	108
2.2	Headlight with Xenon discharge lamps- vehicles up to MY 08	109
2.3	Headlights with Xenon discharge lamps and cornering light - vehicles as of MY 09	113
2.4	Removing and installing control unit for headlight range control J431 or cornering light and headlight range control unit J745	118
2.5	Removing and installing vehicle level sensor G78 front left or G76 rear left	118
2.6	Contact assignment of plug connection for control unit for headlight range control J431 or cornering light and headlight range control unit J745	119
3	Side turn signal lights	120
3.1	Removing and installing side turn signal lights - vehicles up to MY 08	120
3.2	Removing and installing side turn signal lights - vehicles as of MY 09	120
4	Tail lights	122
4.1	Octavia	122
4.2	Octavia Combi	123
5	Fog lights, fog lights with the “Corner” function and daylight driving light	125
5.1	General description, fault recognition and fault display	125
5.2	Removing and installing fog light/daylight driving light	126
5.3	Lamps for daylight driving light - Octavia Scout (vehicles as of CW 22.10)	128
5.4	Replacing the lamp for the fog light and for the fog light with the “Corner” function	128
5.5	Removing and installing light bulb for daylight driving light (except Octavia RS and Scout) - vehicles as of MY 09	129
5.6	Daylight driving light and parking light Octavia “RS” - as of CW 22/09	130
5.7	Adjusting fog lights, fog lights with the “Corner” function	130
6	Additional brake light	131
6.1	Removing and installing the high level brake light - Octavia	131
6.2	Removing and installing the high level brake light - Octavia Combi	131

Reproduction of this document for private or commercial purposes, in part or in whole, is not permitted without the written permission of SKODA AUTO A. S. SKODA does not guarantee or accept any liability with respect to the correctness of information in this document. Copyright by SKODA AUTO A. S. ©

7	Steering column switch	133
7.1	Steering column switch- vehicles up to CW 21/10	133
7.2	Steering column switch- vehicles as of CW 22/10	141
7.3	Setting middle position of the return ring with coil spring	144
8	Steering lock with ignition starter switch and lock cylinder	145
8.1	Removing and installing lock cylinder	145
8.2	Removing and installing steering lock - vehicles up to CW 21/10	146
8.3	Removing and installing steering lock - vehicles as of CW 22/10	146
8.4	Removing and installing ignition/starter switch	147
8.5	Removing and installing ignition key anti-removal lock solenoid N376	148
8.6	Contact assignment on the ignition/starter switch and the ignition key anti-removal lock	149
9	Parking aid	150
9.1	Summary of components	150
9.2	Removing and installing the parking aid control unit J446	151
9.3	Removing and installing the rear parking aid warning buzzer H15	152
9.4	Remove and install the front parking aid warning buzzer H22	152
9.5	Removing and installing parking aid senders	153
9.6	Parking aid sender holder - making holes, assignment, fitting location, glueing procedure	154
9.7	Self-diagnosis of the parking aid	155
10	Door entry lighting	156
10.1	Door entry lighting in the exterior mirror - vehicles up to MY 08	156
10.2	Door entry lighting in the exterior mirror - vehicles as of MY 09	156
11	Registration number lighting	158
11.1	Removing and installing licence plate carrier	158
96	- Lights, bulbs, switches - interior	159
1	Interior Lights	159
1.1	Removing and installing glove box light	159
1.2	Removing and installing door warning lamp	159
1.3	Removing and installing luggage compartment light	160
1.4	Removing and installing the front and rear interior light	160
1.5	Removing and installing the interior light with sliding roof switch	161
1.6	Removing and installing the sliding roof switch	161
2	Interior switches, in the dash panel, the centre console and the doors	162
2.1	Removing and installing light switch	162
2.2	Removing and installing the headlight range control adjuster	162
2.3	Removing and installing switches in centre console	163
2.4	Removing and installing hazard warning lights button	163
2.5	Removing and installing the mirror adjustment switch	164
2.6	Removing and installing the switch for the power window lifter	164
2.7	Removing and installing interior monitoring deactivation switch E 267 and deactivation button for vehicle inclination sender E 360	166
2.8	Removing and installing switch for inside actuation of the central locking	166
2.9	Removing and installing the fuel selector switch E395 (petrol/gas)	166
2.10	Removing and installing the rear seat heating switch	167
3	Components in the luggage compartment and tailgate	168
3.1	Removing and installing the switch for the luggage compartment lighting	168
3.2	Removing and installing the motor for unlocking the tailgate	168
3.3	Removing and installing the tailgate release switch	168
4	Horn	169
4.1	Removing and installing horn	169
5	Anti-theft warning system	170
5.1	General points	170
5.2	Removing and installing the horn H12	170



5.3	Removing and installing interior monitoring sensor G273 and vehicle inclination sender G384	171
5.4	Removing and installing interior monitoring deactivation switch E267 and deactivation button for vehicle inclination sender E360	171
6	12 V power sockets / cigarette lighter	173
6.1	Removing and installing the 12 V power socket/cigarette lighter in the centre console	173
6.2	Removing and installing luggage compartment 12 V socket - Octavia Combi	174
7	Immobiliser	175
7.1	Immobiliser control unit J362	176
7.2	Ignition key	176
7.3	New identity when changing all the components	177
7.4	System test result (online connection)	177
97 - Wiring		178
1	Fuse holder and relay carrier	178
1.1	Removing and installing fuse holder from dash panel	178
1.2	Removing and installing the relay carrier under the vehicle voltage control unit J519 - vehicles as of MY 09	179
1.3	Removing and installing additional relay carrier above the onboard supply control unit	180
1.4	Removing and installing the E-box (relay and fuse carrier in the engine compartment)	182
2	Control units	186
2.1	Onboard supply control unit J519	186
2.2	Central control unit for convenience system J393	189
2.3	Data bus diagnostic interface Gateway J533	191
3	Vehicle diagnosis, testing and information systems	194
4	Wiring loom and plug repair, contact surface cleaning	195

Protected by copyright. Copying for private or commercial purposes, in part or in whole, is not permitted unless authorised by ŠKODA AUTO A. S. ŠKODA AUTO A. S. does not guarantee or accept any liability with respect to the correctness of information in this document. Copyright by ŠKODA AUTO A. S.



ŠKODA



Protected by copyright. Copying for private or commercial purposes, in part or in whole, is not permitted unless authorised by ŠKODA AUTO A. S. ŠKODA AUTO A. S. does not guarantee or accept any liability with respect to the correctness of information in this document. Copyright by ŠKODA AUTO A. S. ©

27 – Starter, current supply, CCS

1 Contact corrosion

(SRL000656; Edition 12.2013)

The use of unsuitable connection elements (screws, nuts, washers, etc.) causes contact corrosion.

This is why only connection elements with a special surface coatings are fitted.

Therefore, the rubber or plastic parts and the adhesives are made from electrically non-conductive materials.

In case of doubt regarding the re-use of certain parts, the use of new parts is recommended.



WARNING

- ◆ *It is recommended to use only original connection material as well as spare parts which are tested and compatible with aluminium, see ⇒ [Electronic Catalogue of Original Parts](#) .*
- ◆ *It is recommended to use only Škoda accessories.*
- ◆ *Any damage resulting from contact corrosion is not covered by the terms of the warranty.*



Note

- ◆ *It is possible to use the contact surface cleaning set - VAS6410- for repair work on contact surfaces, which show traces of contact corrosion (oxydation).*
- ◆ *Examples for application of the contact surface cleaning set - VAS6410- can be found in the Workshop Manual "Electrical System - General notes" ⇒ [Electrical System - General notes; Rep. gr. 97](#) .*

Protected by copyright. Copying for private or commercial purposes, in part or in whole, is not permitted unless authorised by ŠKODA AUTO A. S. ŠKODA AUTO A. S. does not guarantee or accept any liability with respect to the correctness of information in this document. Copyright by ŠKODA AUTO A. S. ©



2 Battery



WARNING

When working on the battery wear proper protection and observe safety precautions (see "Electrical System - General notes" ⇒ [Electrical System - General notes; Rep. gr. 27](#)).

⇒ ["2.1 Basics", page 2](#)

⇒ ["2.2 Warning instructions and safety precautions when working on the battery", page 2](#)

⇒ ["2.3 Work sequence when disconnecting and connecting the battery", page 2](#)

⇒ ["2.4 Checking battery", page 5](#)

⇒ ["2.5 Charging battery", page 5](#)

⇒ ["2.6 Removing and installing battery", page 5](#)

⇒ ["2.7 Removing and installing the battery tray in the engine compartment", page 6](#)

⇒ ["2.8 Battery parameterisation", page 7](#)

2.1 Basics

Batteries with a magic eye and plugs covered in adhesive tape are factory-installed in all vehicles (except Green Line II vehicles with start-stop system).

In Green Line II vehicles with start/stop system, (depending on types of engines see ⇒ [Electronic Catalogue of Original Parts](#)) a fleece battery (AGM) or a battery with magic eye with EFB technology (Enhanced Flooded Battery) is mounted.

Description of the function, test and maintenance of the previous batteries see "Electrical System – General notes" ⇒ [Electrical System – General notes; Rep. gr. 27](#) .

2.2 Warning instructions and safety precautions when working on the battery

All notes and comments to this chapter can be found in the Workshop Manual "Electrical system - General notes" ⇒ [Electrical system - General notes; Rep. gr. 27](#) .

2.3 Work sequence when disconnecting and connecting the battery

⇒ ["2.3.1 Disconnect battery", page 2](#)

⇒ ["2.3.2 Work sequence when connecting the battery", page 3](#)

2.3.1 Disconnect battery



Note

Query the code of the radio or navigation system before disconnecting the battery. This does not apply for radio and navigation systems installed at the works see ⇒ [page 30](#) .

Protected by copyright. Copying for private or commercial purposes, in part or in whole, is not permitted unless authorised by ŠKODA AUTO A. S. ŠKODA AUTO A. S. does not guarantee or accept any liability with respect to the correctness of information in this document. Copyright by ŠKODA AUTO A. S. ©

- Switch off all electrical components and take out the ignition key.
- Remove battery cover -1-, to do so press the release button -arrow-.

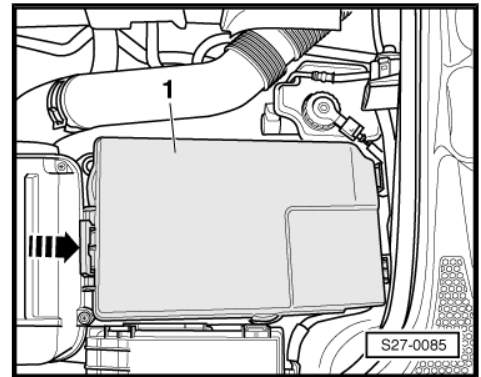

- Release nut -arrow- and only disconnect earth strap of battery.



If both terminals are disconnected, only then disconnect pole terminal (-) from battery earth.

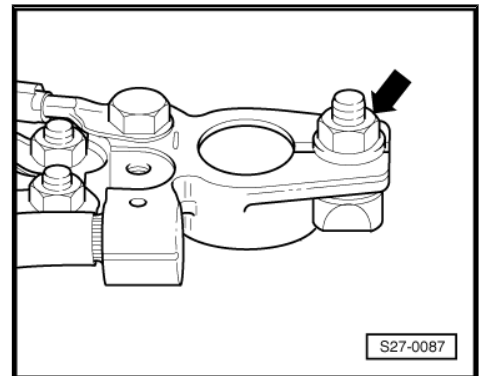

2.3.2 Work sequence when connecting the battery



WARNING

Observe the following additional instructions after working on the airbag system or on the electric belt tighteners or the safety belts:

◆ *Switch on the ignition before connecting the battery.*

◆ *Nobody should be in the vehicle when the battery is being connected.*

Protected by copyright. Copying for private or commercial purposes, in part or in whole, is not permitted unless authorized in writing by SKODA AUTO A. S. with respect to the information in this document. Copyright by SKODA AUTO A. S.

Note

- ◆ *Neither grease nor oil the battery terminals.*
 - ◆ *The battery pole terminals must only be fitted by hand without using any force in order to avoid damaging the battery housing.*
 - ◆ *Install the battery pole terminals in such a way that the battery poles are flush with the terminals or protrude.*
 - ◆ *If both terminals are disconnected, only then disconnect the battery positive pole terminal (+).*
 - ◆ *The tightening torque is the same for all shapes of pole terminals (6 Nm).*
 - ◆ *After connecting the battery and switching on the ignition, the warning light for the stability program TCS/ESP and the warning light for the power-assisted steering remain lit. The warning lights go out automatically after driving a few metres forward. Thereby the steering angle sender - G85- is activated again.*
- Switch off all electrical components and take out the ignition key.

Vehicles with battery monitoring control unit - J367- (with start-stop system)

- Disconnect the plug -3- from the control unit -2- before connecting to the battery.
- Fit pole terminal (-) with control unit onto the “-” pole of the battery, see fig., and tighten the fixing nut -1- (6 Nm).
- Fit the plug -3- again onto the control unit.

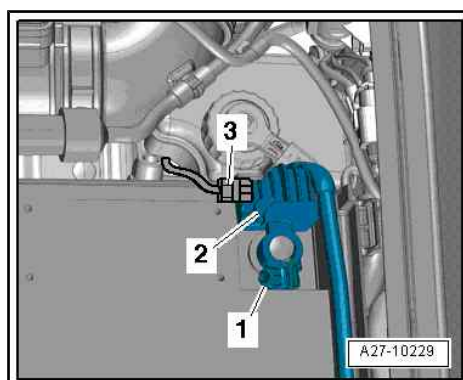

Vehicles without battery monitoring control unit - J367-

- Fit battery pole terminal of earth line onto negative terminal of battery and tighten the nut -arrow- (6 Nm).

Continued for all vehicles:

When the battery is reconnected, perform the following operations depending on the vehicle equipment:

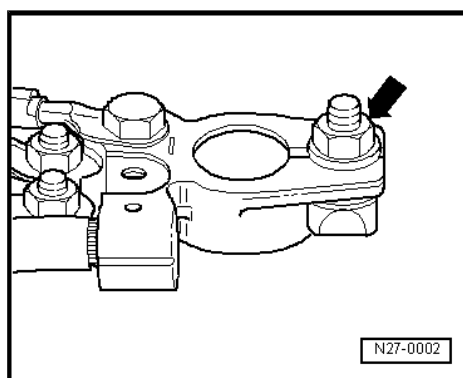
- ◆ Set clock.
- ◆ Check the power windows ⇒ Maintenance ; Booklet Octavia II .
- ◆ Radio/navigation with anti-theft coding (not valid for radio systems/navigation systems assembled at the factory, see ⇒ [page 30](#)) ⇒ operating manual of the radio system/navigation system .
- ◆ Connect the ⇒ Vehicle diagnostic tester, query the event memory and delete any event memory entries.



2.4 Checking battery

All the notes and comments to the following chapters can be found in the Workshop Manual "Electrical System - General notes" ⇒ Electrical System - General notes; Rep. gr. 27 .

- ◆ Visual inspection
- ◆ Check battery with a magic eye
- ◆ Measuring no-load voltage
- ◆ Measuring voltage under load
- ◆ Check current drain when charging

2.5 Charging battery

All notes and comments to this chapter can be found in the Workshop Manual "Electrical system - General notes" ⇒ Electrical system - General notes; Rep. gr. 27 .

2.6 Removing and installing battery



WARNING

Observe the battery handling instructions as well as the warning instructions and safety precautions for lead acid batteries ⇒ [page 2](#) .

Removing

- Switch off all electrical components and take out the ignition key.
- Disconnect the earth cable and then the positive terminal of the battery ⇒ [page 2](#) .

Vehicles with the battery located in the plastic cover:

- Vehicles with diesel engine - screw out the fixing screws of the upper cover for air suction and fold away to the side. Protect the air filter with the cover to prevent any dirt from penetrating.
- Pull the front of the battery housing upwards -arrow-.

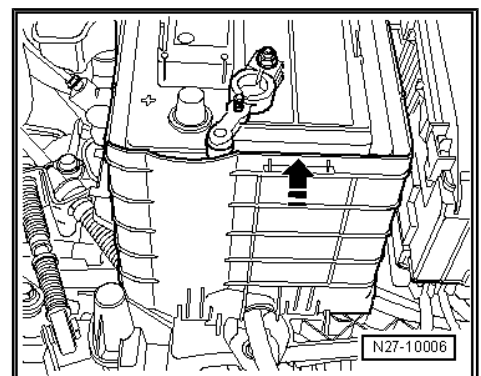

- Release screw -1- (22 Nm).
- Remove the retaining clamp -2- and take out the battery.

Vehicles with the battery located in the polyester housing:

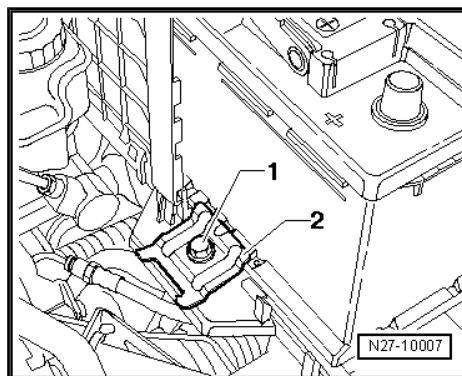

- Vehicles with diesel engine - screw out the fixing screws of the upper cover for air suction -1- and fold away to the side. Protect the air filter with the cover to prevent any dirt from penetrating.
- After disconnecting the terminals -arrows- pull out the polyester housing -2- towards the top.
- Release screw -4- (22 Nm).
- Remove the retaining clamp -3- and take out the battery.

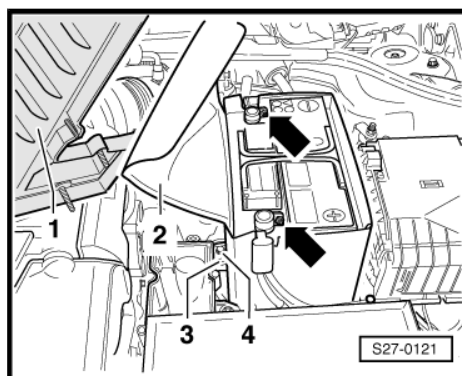

Installing

Installation is carried out in the reverse order. When installing, observe the following:

- The battery is properly installed when the middle recess of the front battery foot strip is aligned at the bottom with the bore in the battery tray -arrows-.
- Observe the instructions after reconnecting the battery ➔ [page 2](#) .

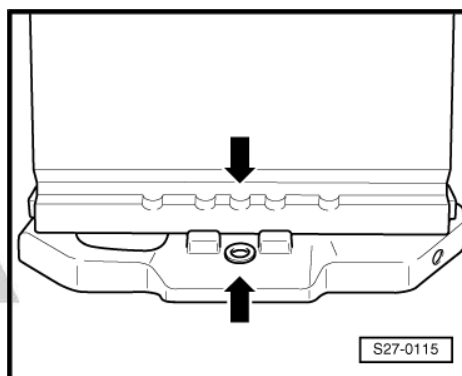

⚠ Caution

There are certain dangers if the battery is incorrectly mounted or mounted loosely:

- ◆ *Shortened service life due to damage from vibration (danger of explosion)*
- ◆ *Damage to the grid plates of the battery.*
- ◆ *Damage to battery housing by securing bracket (possibility of acid leaking, with high consequential costs)*
- ◆ *Poor crash safety*

2.7 Removing and installing the battery tray in the engine compartment

Removing

- Remove air filter housing ➔ Engine; Rep. gr. 23 diesel engines or ➔ Engine; Rep. gr. 24 petrol engines.
- Remove the battery ➔ [page 5](#) .
- Remove bracket with liquefied petroleum gas control unit (only LPG vehicles) ➔ Engine; Rep. gr. 24 .

Reproduction, distribution, or use for commercial purposes, in part or in whole, is not permitted unless authorised by SKODA AUTO A. S. SKODA AUTO A. S. does not guarantee or accept any liability with respect to the correctness of information in this document. Copyright by SKODA AUTO A. S. ©

- Screw out the screws -arrows- (9 Nm) and remove the battery tray.

Installing

Installation is carried out in the reverse order. When installing, observe the following:

- On LPG vehicles, spacer washers of 4 mm thickness are fitted between the bracket and the body below the front screws -bottom arrows-.

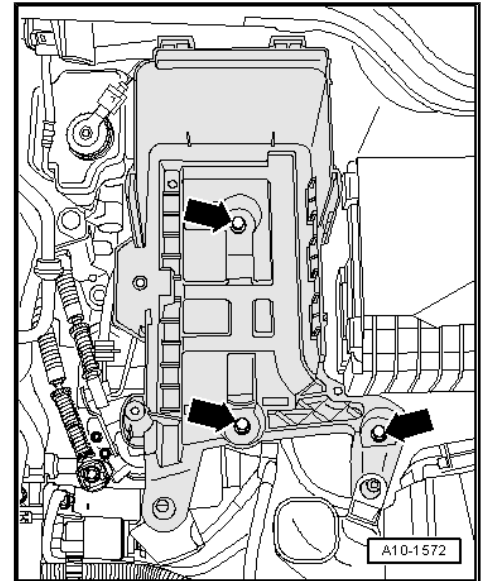

2.8 Battery parameterisation

It is performed on vehicles with a start-stop system when replacing the battery with a new one of another type or with higher capacity.

After a new start battery is installed and the battery has been parameterised, the technical data of the new battery are sent to the battery monitoring control unit - J367- .

- ⇒ Vehicle diagnostic tester connect and select the operating mode "Targeted fault-finding".
- Select the "Selected Functions/Components" and subsequently the following menu points using the button "Skip":
 - ◆ Body
 - ◆ Electrical system
 - ◆ Diagnostic capable systems
 - ◆ Checking battery
 - ◆ Battery monitoring function
 - ◆ Adaption battery parameterisation



3 Battery types

⇒ "3.1 Battery with a magic eye", page 8

⇒ "3.2 Fleece battery (AGM battery)", page 8

3.1 Battery with a magic eye

Located in the engine compartment.

All notes and comments to this chapter can be found in the Workshop Manual ⇒ Electrical system - General notes ⇒ Electrical system - General notes; Rep. gr. 27 .



Note

- ◆ *A battery with a magic eye with EFB technology (Enhanced Flooded Battery) can also be fitted in vehicles with petrol engines and with start-stop system. It is fitted with thicker plates and separators with special polyester scrim. Thereby the cycle durability as well as the loading capacity are considerably increased in order to recover the energy more quickly while driving.*
- ◆ *Maintenance and checks on these batteries are the same as on batteries with a magic eye.*

3.2 Fleece battery (AGM battery)

All notes and comments to this chapter can be found in the Workshop Manual ⇒ Electrical system - General notes ⇒ Electrical system - General notes; Rep. gr. 27 .

4 Starter

⇒ "4.1 Removing and installing starter", page 9

4.1 Removing and installing starter

Removing

- Disconnect battery earth strap ⇒ [page 2](#) .
- Remove air filter housing ⇒ Engine; Rep. gr. 23 diesel engines or ⇒ Engine; Rep. gr. 24 petrol engines.
- Move the protective cover -arrow-.

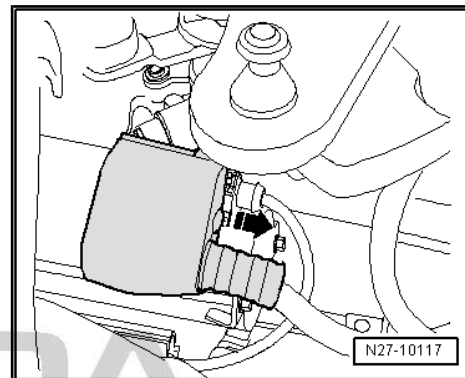

- Unscrew nut -3- and disconnect positive cable.
- Unlock and pull off connector -2-.
- Release nut -1- and loosen battery earth strap.

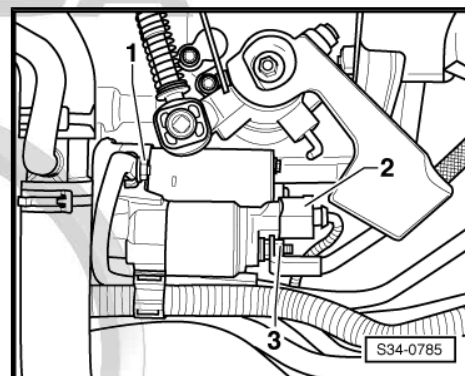

- Then screw out top fixing screw for starter -arrow-.
- M12 - 80 Nm
M10 - 40 Nm

Vehicles fitted with a manual gearbox:

- Remove noise insulation ⇒ Body Work; Rep. gr. 50 .

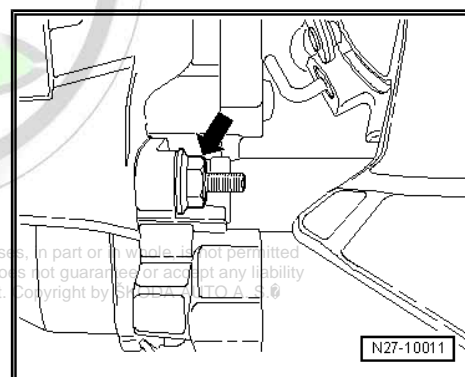

Protected by copyright. Copying for private or commercial purposes, in part or in whole, is not permitted unless authorised by ŠKODA AUTO A. S. ŠKODA AUTO A. S. does not guarantee or accept any liability with respect to the correctness of information in this document. Copyright by ŠKODA AUTO A. S. ©



- Unscrew nut -1- (23 Nm) and lay aside line holder -2- together with line.

All vehicles:

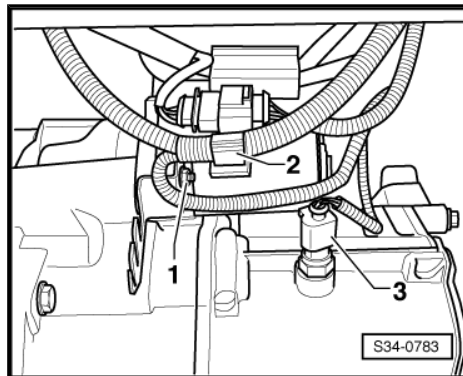

- Screw out bottom fixing screw -arrow- and remove the starter.

M12 - 80 Nm

M10 - 40 Nm

Installing

Installation is carried out in the reverse order. When installing, observe the following:

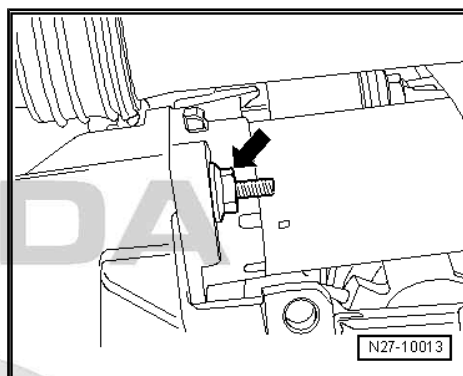

i Note

Use new self-locking nuts -1- and -3- for attaching the earth strap and the positive cable, see => *Electronic Catalogue of Original Parts* .

Tightening torques for positive cable and earth strap:

Battery earth strap, Pos. -1- 20 Nm

Positive cable, Pos. -3-:

- ◆ Starter with copper screw 16 Nm
- ◆ Starter with steel screw 20 Nm

- Follow the work procedure when connecting the battery
=> [page 2](#) .

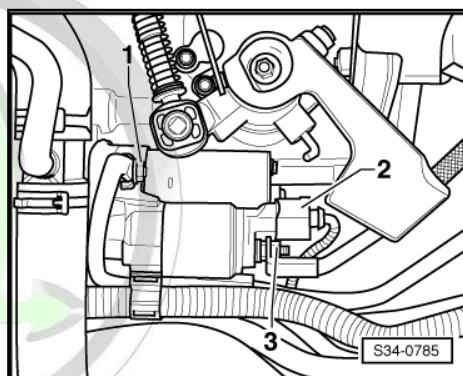

Protected by copyright. Copying for private or commercial purposes, in part or in whole, is not permitted unless authorised by ŠKODA AUTO A. S. ŠKODA AUTO A. S. does not guarantee or accept any liability with respect to the correctness of information in this document. Copyright by ŠKODA AUTO A. S. ©

5 Alternator

⇒ [“5.1 Checking generator”, page 11](#)

⇒ [“5.2 Removing and installing alternator”, page 11](#)

⇒ [“5.3 Fixing the B+ wire to the AC generator”, page 13](#)

⇒ [“5.4 Checking the carbon brushes of the AC generator”, page 13](#)

⇒ [“5.5 Removing and installing the Bosch voltage regulator”, page 14](#)

⇒ [“5.6 Removing and installing the Valeo voltage regulator”, page 14](#)

⇒ [“5.7 Removing and installing V-ribbed belt pulley on alternator”, page 15](#)

⇒ [“5.8 Removing and installing the V-ribbed belt pulley with free wheel”, page 15](#)

5.1 Checking generator

The AC generator can be checked with the ⇒ Vehicle diagnostic tester in the function “Targeted fault finding” under Body / Electrical system / 27 - Starter, voltage supply / electrical components / AC generator - C- .

5.2 Removing and installing alternator

Removing

- Disconnect battery earth strap ⇒ [page 2](#) .
- Remove the V-ribbed belt ⇒ Engine; Rep. gr. 13 .

Vehicles with TDI engines with common rail injection:

- Remove the fuel filter ⇒ Engine; Rep. gr. 20 and lay it to the side (do not detach hoses).
- Remove charge air hose and charge air pipe ⇒ Engine; Rep. gr. 21 .

Vehicles with TDI engines with Common Rail injection and 1.2/1.4 TSI:

- Remove noise insulation ⇒ Body Work; Rep. gr. 50 .
- Remove radiator fan ⇒ Engine; Rep. gr. 19 .
- Remove AC compressor (do not open the refrigerant circuit) and secure to the side so that the intake hoses are not excessively strained ⇒ Heating, Air Conditioning; Rep. gr. 87 .
- 1.2 TSI engine - remove guide pulley ⇒ Engine; Rep. gr. 13 .

Vehicles with 1.6 - 75 kW/2.0 FSI engines - AC generator secured from the front side:

- Remove tensioning pulley ⇒ Engine; Rep. gr. 13 .

All vehicles:

SKODA

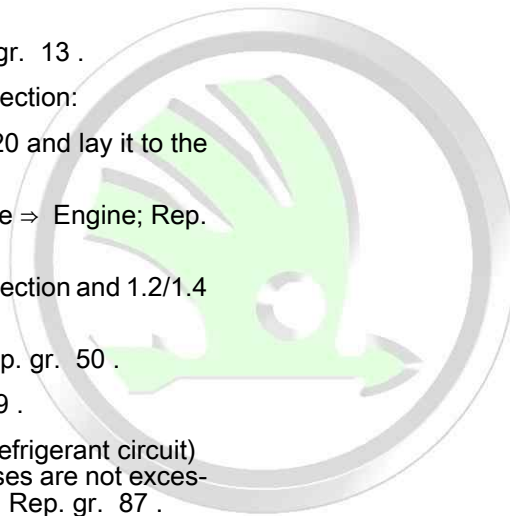

or commercial purposes, in part or in whole, is not permitted unless authorised by ŠKODA AUTO A. S. ŠKODA AUTO A. S. does not guarantee or accept any liability for the content of this document. Copyright by ŠKODA AUTO A. S. ©

- Remove the screen cap from the fixing nut of the B+ cable -1- and unscrew the nut.
- Disconnect plug connection -2-.
- Unscrew the securing nut (3.2 Nm) for line holder -3- and lay the line to the side.

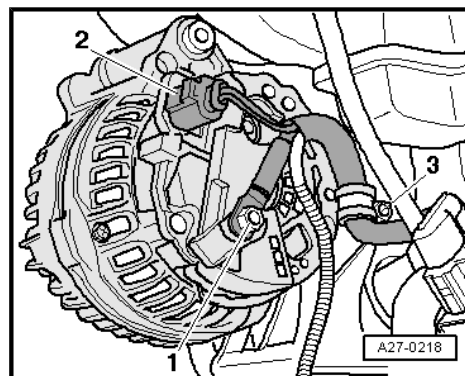

- Vehicles with AC generator secured from the front side - screw out screws -arrows- (23 Nm).

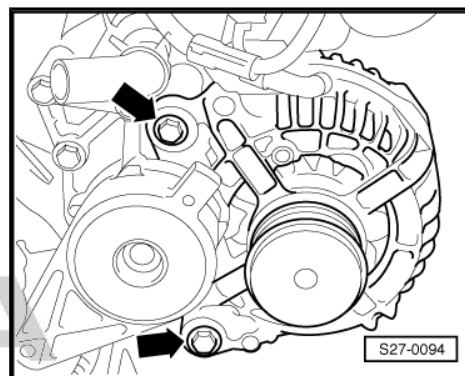

- Vehicles with AC generator secured from the side - screw out screws -arrows- (23 Nm).

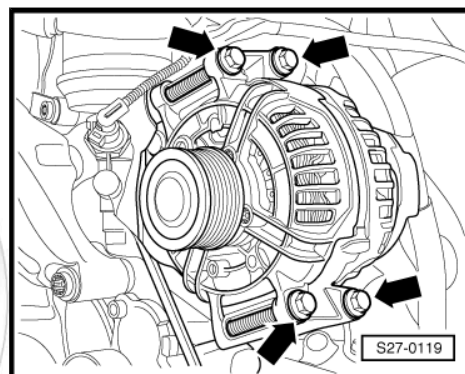

Vehicles with TDI engines with Common Rail injection and 1.2/1.4 TSI:

- Remove AC generator downwards.

Other vehicles:

- Remove AC generator upwards.

Installing

Installation is carried out in the reverse order. When installing, observe the following:

- Vehicles with AC generator secured from the front side – for easier mounting move the threaded bushes -A- approx 3 mm -arrows-.
- Observe the tightening torque for fastening the B+ wire see [=> page 13](#) .
- Follow the work procedure when connecting the battery [=> page 2](#) .

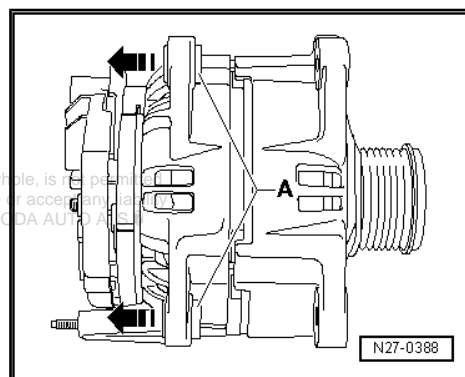

5.3 Fixing the B+ wire to the AC generator



Caution

The screw connection for the B+ cable at the generator is identified with B1+!

If the B+ cable is not tightened to the specified tightening torque, this may result in the following risks:

- ◆ *The battery will not charge fully.*
- ◆ *Complete failure of vehicle electronics*
- ◆ *Spark formation may cause a fire*
- ◆ *Damage resulting from overvoltage on electronic components and control units*



Note

Always use a new self-locking nut for attaching the B+ cable -arrow-, see → Electronic Catalogue of Original Parts .

The tightening torque for the self-locking nut of the B+ cable -arrow- is 20 Nm.

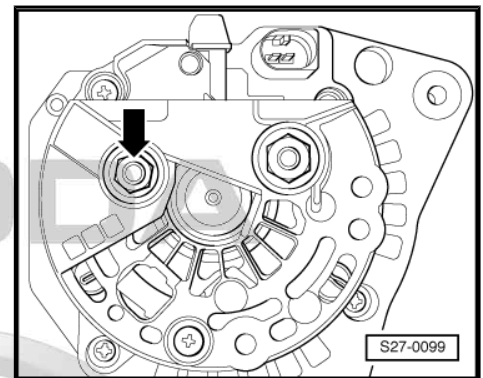

5.4 Checking the carbon brushes of the AC generator

Length of carbon brushes when new = 12 mm

Wear limit = 5 mm

Tolerance of carbon brushes to each other = +1 mm

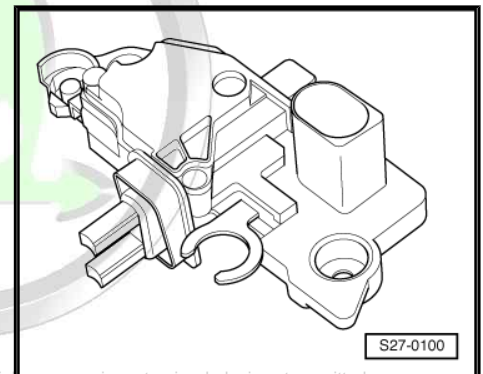

Protected by copyright. Copying for private or commercial use without the written permission of ŠKODA AUTO A. S. ŠKODA AUTO A. S. does not guarantee or accept any liability with respect to the correctness of information in this document. Copyright by ŠKODA AUTO A. S.®

5.5 Removing and installing the Bosch voltage regulator

- Unscrew the fixing nuts -arrows A- and release the fixing screw -arrow B- of the screen cap.
- Remove cover.

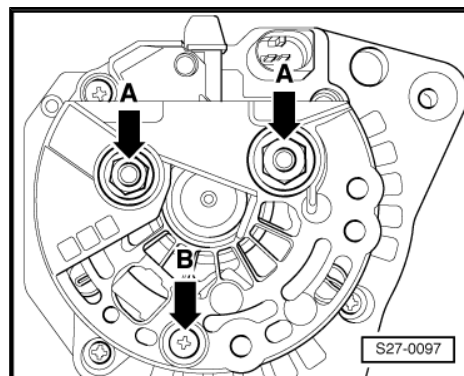

- Unscrew the fixing screws -arrows- of the voltage regulator and remove voltage regulator.
- The installation occurs in reverse order.

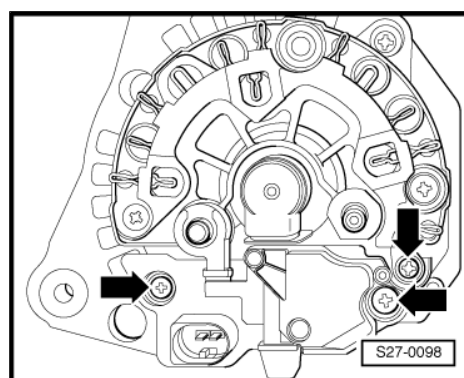

5.6 Removing and installing the Valeo voltage regulator

- Press off protective cap on the rear side of the generator -arrows-.

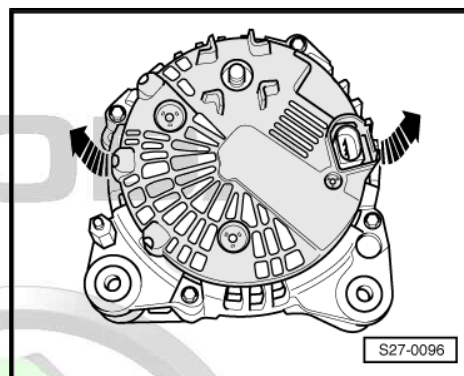

- Release screws -1- and nut -2-.
- Remove voltage regulator.
- The installation occurs in reverse order.

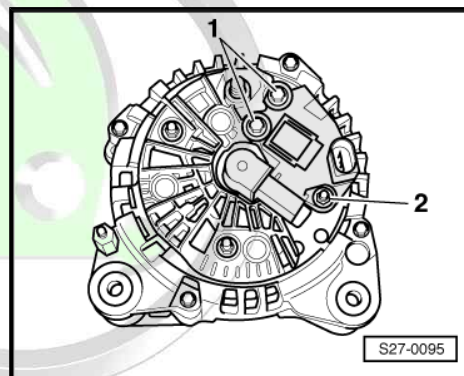

5.7 Removing and installing V-ribbed belt pulley on alternator

Special tools and workshop equipment required

- ◆ Socket - T30032-
- Remove V-ribbed belt and/or generator ⇒ [page 11](#) .
- Remove the V-ribbed belt pulley using the socket insert - T30032- .

Removal - turn the alternator shaft to the right.

Installation - turn the alternator shaft to the left.

Tightening torque: 65 Nm

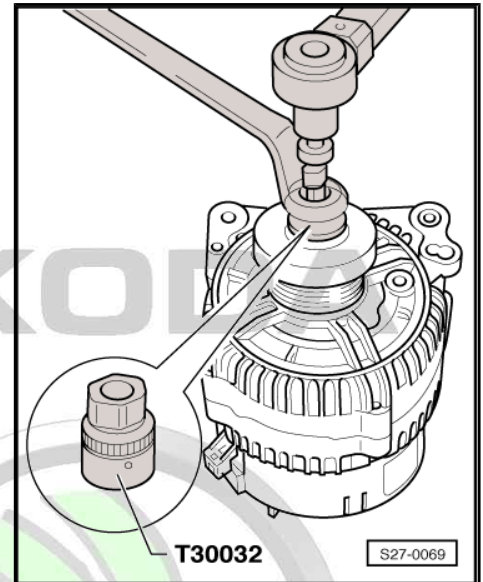

5.8 Removing and installing the V-ribbed belt pulley with free wheel

Special tools and workshop equipment required

- ◆ Polygon-head adapter - MP 1-309-
- Remove V-ribbed belt and/or generator ⇒ [page 11](#) .
- Remove the poly-V belt pulley using the polygon-head adapter - MP 1-309- .

Removal - turn the alternator shaft to the right.

Installation - turn the alternator shaft to the left.

Tightening torque: 80 Nm

- Clip the protective cap onto the belt pulley with free wheel.

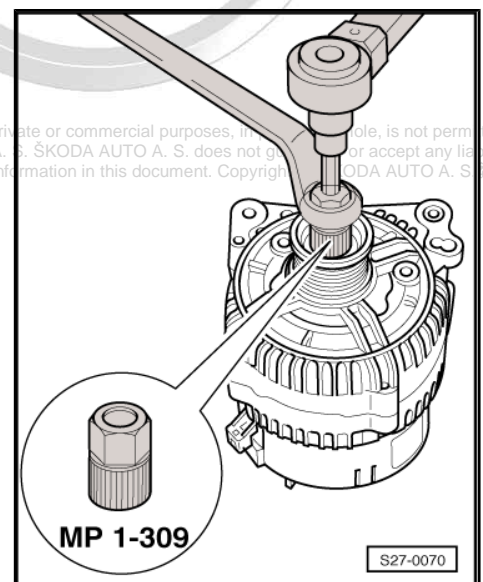



6 Removing and installing the cruise control (CC)

The engine control unit controls the function of the CC on vehicles which have a cruise control.

Apart from the CCS control switch in the left steering-column switch there are no additional components of the CCS.

Fault recognition and fault display

Faults from the Cruise control system are transmitted via the engine control unit.

For fault finding use:

- ◆ ⇒ Vehicle diagnostic tester in the function "Targeted fault finding".
- ◆ ⇒ Current flow diagrams, Electrical fault finding and Fitting locations.



Protected by copyright. Copying for private or commercial purposes, in part or in whole, is not permitted unless authorised by ŠKODA AUTO A. S. ŠKODA AUTO A. S. does not guarantee or accept any liability with respect to the correctness of information in this document. Copyright by ŠKODA AUTO A. S. ©

7 "Start-stop" system

⇒ ["7.1 Safety precautions for vehicles with start-stop system", page 17](#)

⇒ ["7.2 General description", page 17](#)

⇒ ["7.3 Fault recognition and fault display", page 18](#)

⇒ ["7.4 Battery recharging or starting by external source on vehicles with start-stop system", page 18](#)

⇒ ["7.5 Replacing the battery on vehicles with start-stop system", page 18](#)

⇒ ["7.6 Voltage stabiliser J532", page 19](#)

⇒ ["7.7 Battery monitor control unit J367", page 19](#)

⇒ ["7.8 Button for start-stop system", page 20](#)

7.1 Safety precautions for vehicles with "start-stop" system



Caution

Risk of injury from automatic engine start.

- ◆ ***On vehicles with activated start-stop system (recognizable by a message in the dash panel insert) there is a risk that the engine can start automatically.***
- ◆ ***It is therefore necessary to ensure that the start-stop system is deactivated when carrying out work on the vehicle (switch ignition off, if required switch ignition on again).***

7.2 General description

The start-stop system is designed to reduce fuel consumption and thus contributes to the reduction of pollutant emissions.

For this purpose the engine automatically switches off during standstill phases of the vehicle and restarts automatically or when operating the clutch pedal.

The system is always automatically activated when the ignition is switched on and can be deactivated with the "start-stop" button in the centre console.

Detailed description of the function as well as conditions for the operation of the start-stop system see:

- ◆ ⇒ Self-study programme No. 86 ; Start-stop system in Škoda vehicles
- ◆ ⇒ Owner's manual Octavia II

Connection diagram of the start-stop system ⇒ Current flow diagrams, Electrical fault finding and Fitting locations.

**Note**

- ◆ *The components adapted for the start-stop system are not specifically designated and differ only slightly from the usual components (e.g. starter, generator).*
- ◆ *When carrying out repairs, pay attention to the correct designation of the spare parts see ⇒ *Electronic Catalogue of Original Parts* .*

7.3 Fault recognition and fault display

The start-stop system is implemented in the software of the engine control unit - J623- as a function.

The engine control unit is equipped with self-diagnosis, which facilitates the fault finding.

For fault finding use the ⇒ Vehicle diagnostic tester in the function "Targeted fault finding".

7.4 Battery recharging or starting by external source on vehicles with "start-stop system"

When recharging or jump start on vehicles with start/stop system, observe the following:

Do not disconnect the earth strap of the battery when recharging.

First of all connect to the positive terminals using the charge or jump leads; then connect to the body mass (do not connect to the negative terminal of the battery).

**Note**

- ◆ *The direct charging (starting aid) of the battery at the negative terminal results in the bypass of the battery monitoring control unit - J367- (then the current flow is not monitored by this control unit).*
- ◆ *The values regarding the battery state, which are stored in the data bus diagnostic interface - J 533- (Gateway), would then no longer correspond to the values of the charged battery.*
- ◆ *This can lead to the failure of the start-stop system.*
- ◆ *Test and charging procedure for the battery "Electrical System - General notes" ⇒ *Electrical System - General notes; Rep. gr. 27* .*

7.5 Replacing the battery on vehicles with "start-stop" system

Owing to their greater cycle stability during cold starting, (according to engine type, see ⇒ *Electronic Catalogue of Original Parts*) a fleece battery (Absorbed Glass Mat) or a battery with a magic eye using EFB (Enhanced Flooded Battery) technology are used as starter battery in place of the usual lead-acid batteries.

When replacing the battery, only install a fleece battery (AGM) again or a battery with EFB technology with the same capacity (see ⇒ *Catalogue of original parts*).

When replacing the battery with a new one, another type of battery or a battery of a higher capacity you must set the battery parameters, see ⇒ [page 7](#) .

i Note

Description of the function, test and maintenance of the previous batteries see "Electrical System – General notes" => Electrical System – General notes; Rep. gr. 27.

7.6 Voltage stabiliser - J532-

The voltage stabilizer - J532- is located under the left front seat.

Its task is to stabilise the high voltage drop of the on-board power supply, resulting from the start-stop operation, to 12 volts.

If it becomes apparent that the electrical consumers (such as radio/navigation, telephone, dash panel insert) must be reset at each engine start, while operating the start-stop system, this indicates that the voltage stabilizer is defective.

If the above mentioned electrical consumers fail at the same time, first of all check the fuse of the voltage stabilizer see => Current flow diagrams, Electrical fault finding and Fitting locations.

A direct entry relating to a malfunction of the voltage stabilizer via => Vehicle diagnostic tester is not made at present.

Removing

- Switch off the ignition and all electrical consumers!
- Push the left front seat as far backward as possible and to the highest point.
- Slightly raise the edges of the cover -arrows A- and pull out the cover -arrow B-.

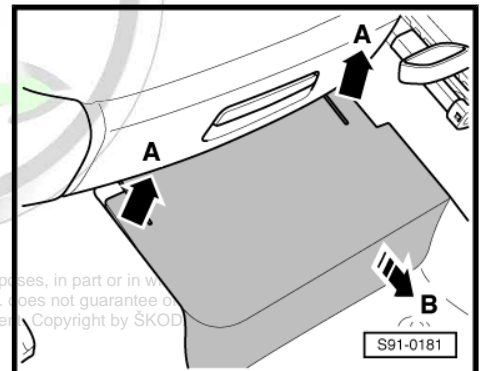

Protected by copyright. Copying for private or commercial purposes, in part or in whole, is prohibited unless authorised by ŠKODA AUTO A. S. ŠKODA AUTO A. S. does not guarantee the accuracy of the information with respect to the correctness of information in this document. Copyright by ŠKODA AUTO A. S.

- Unscrew fixing screws -arrows- (3 Nm).
- Disconnect plug and remove the unit.

Installing

The installation occurs in reverse order.

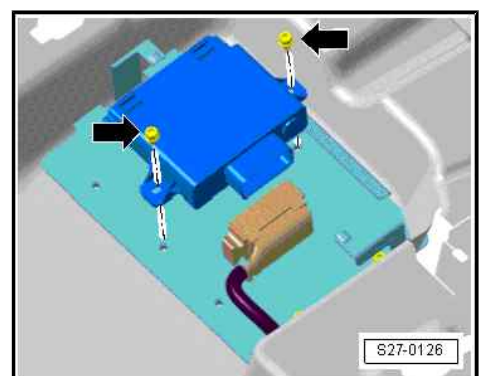

7.7 Battery monitor control unit - J367-

The control unit is located directly at the negative connection terminal of the battery earth strap.

It transmits information on whether the battery has enough electric power for the operation of the start-stop system.



It is connected to the data bus diagnostic interface - J533- (Gateway) via the LIN data bus.

In the event of a failure, an entry is made in the event memory.
The start-stop system is switched off.



Note

After replacing, adapt (code) the new battery monitoring control unit - J367- with ⇒ Vehicle diagnostic tester.

7.8 Button for “start-stop” system

Removing and installing the button for the start-stop system
⇒ [page 163](#) .



Protected by copyright. Copying for private or commercial purposes, in part or in whole, is not permitted unless authorised by ŠKODA AUTO A. S. ŠKODA AUTO A. S. does not guarantee or accept any liability with respect to the correctness of information in this document. Copyright by ŠKODA AUTO A. S. ©

90 – Gauges, instruments

1 Dash panel insert

Technology of the dash panel insert

The dash panel insert is supplied in three versions:

Basic design:

- ◆ Rev counter
- ◆ Speedometer
- ◆ Kilometre counter, trip counter and service interval display (SID)
- ◆ Coolant temperature gauge
- ◆ Fuel gauge
- ◆ Indicator/warning lights (all LED types)
- ◆ Immobiliser

Dash panel insert with multifunction display:

Compared to the basic design, this one is also available with a multifunction display, on which the following functions are displayed:

- ◆ Average consumption
- ◆ Momentary consumption
- ◆ Range
- ◆ Driving time
- ◆ Average speed
- ◆ Distance

Dash panel insert with maxidot display:

Compared to the dash panel with multifunction display, this one is available additionally with an information display:

- ◆ An information display for showing radio and navigation data, as well as details regarding the service intervals and the selector lever positions on the automatic gearbox.

Description of the function and control:

- ◆ ⇒ Owner's manual Octavia II
- ◆ ⇒ Self-study programme No. 54 ; Škoda Octavia II Electrical Components

Contact assignment of plug connection on the dash panel insert
⇒ Current flow diagrams, Electrical fault finding and Fitting locations.

⇒ ["1.1 Adjust/replace dash panel insert", page 22](#)

⇒ ["1.2 Removing and installing the dash panel insert", page 22](#)

⇒ ["1.3 Relacing shield with transparent washer", page 24](#)

⇒ ["1.4 Warning light symbols in dash panel insert - vehicles up to MY 08", page 25](#)

⇒ ["1.5 Warning light symbols in dash panel insert - vehicles as of MY 09", page 26](#)



⇒ "1.6 Service interval display", page 27

1.1 Adjust/replace dash panel insert



Note

Before replacing the dash panel insert the code of the radio system/navigation, which must be newly adjusted after replacing the dash panel insert, must be determined see ⇒ [page 30](#).

⇒ Vehicle diagnostic tester connect on-line (network connection).

If the dash panel insert is replaced, the ⇒ Vehicle diagnostic tester must be connected before removing the original dash panel insert and "replace dash panel insert" must be selected in the guided functions. Thereby, the required values are read into the diagnostic unit from the original dash panel insert. If the original dash panel insert is not available or does not communicate with the diagnostic unit, then proceed according to the information in the ⇒ Vehicle diagnostic tester.

After fitting the new dash panel insert, adapt all ignition keys.

1.2 Removing and installing the dash panel insert

Special tools and workshop equipment required

- ◆ Release tool - T 30098-



Note

- ◆ After reading in the information stored in the control unit, the work sequence "adjust/replace dash panel insert" must be carried out before replacing the dash panel insert ⇒ [page 22](#).
- ◆ The dash panel insert must not be disassembled, only the shield with transparent washer attached with clips is replaceable ⇒ [page 24](#).

Removing

- Switch off the ignition and all electrical consumers!
- Pull steering wheel out fully and lock it in its lowest position.
- Remove light switch ⇒ [page 162](#).
- Release catches and remove the left -2- and right -1- cover.
- Push out the gap cover between dash panel insert and top steering column trim panel towards you and remove together with the top steering column trim panel.

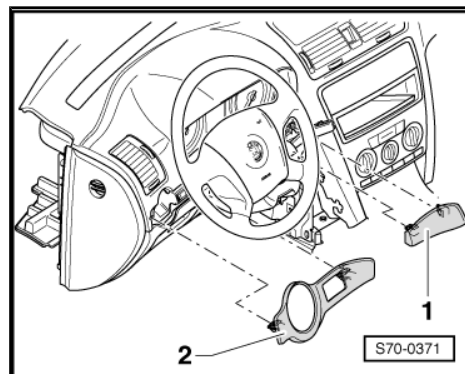

- Release screws -arrows- (1,5 Nm).

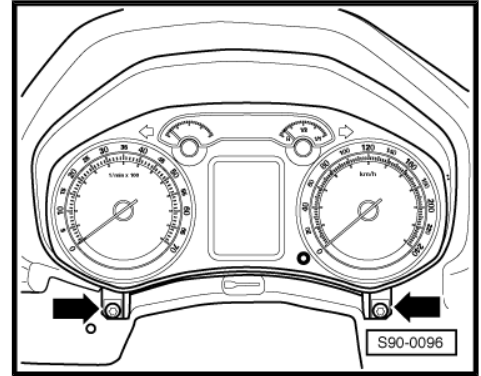

- Insert release tool -T 30098- as shown in the figure and release the upper clips of the dash panel insert (they must click audibly).
- Pull out the dash panel insert slightly and unplug the plug connection.
- Take out the dash panel insert.

Installing

The installation occurs in reverse order.

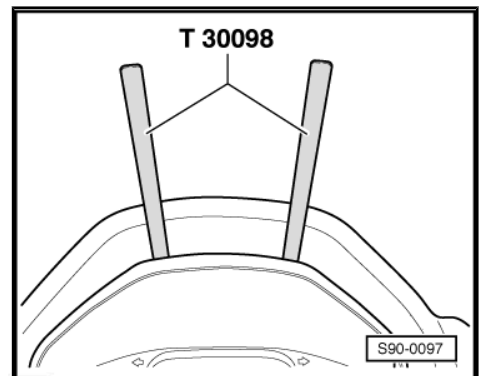

Dash panel insert - vehicles up to MY 2008 - rear view

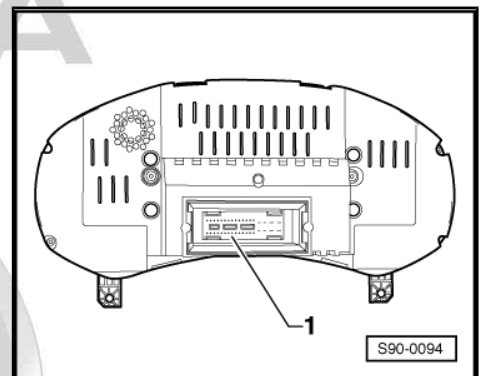

Dash panel insert - vehicles as of MY 2009 - rear view



Note

- ◆ For fault finding perform self-diagnosis ⇒ [page 29](#) .
- ◆ Contact assignment of plug connection ⇒ *Current flow diagrams, Electrical fault finding and Fitting locations.*

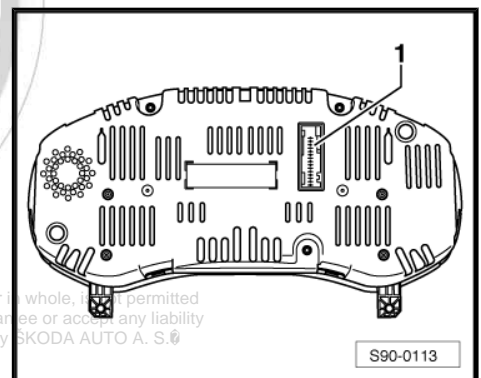

Protected by copyright. Copying for private or commercial purposes, in part or in whole, is not permitted unless authorised by ŠKODA AUTO A. S. ŠKODA AUTO A. S. does not guarantee or accept any liability with respect to the correctness of information in this document. Copyright by ŠKODA AUTO A. S. ©



1.3 Relacing shield with transparent washer

i Note

- ◆ *The shield with transparent washer must be replaced in a dust-free area, while doing so ensure maximum cleanliness.*
- ◆ *The new shield with transparent washer varies depending on the type and year of manufacture, see ⇒ *Electronic Catalogue of Original Parts* .*

– Remove dash panel insert ⇒ [page 22](#) .



Caution

Do not touch the needles of the displays! There is the risk of damage to the correct calibration or the stepper motor!

Vehicles up to MY 2008:

- Carefully unlatch the shield with transparent washer from the latch clips -arrows-.

Vehicles as of MY 2009:

- Unscrew securing bolts -arrows-.

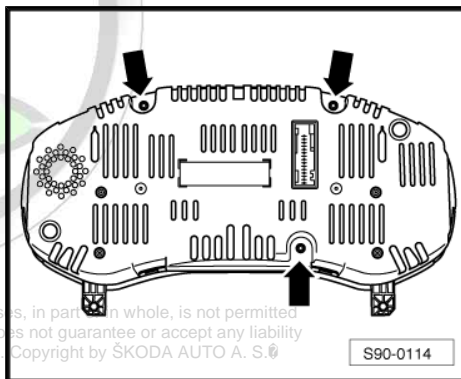
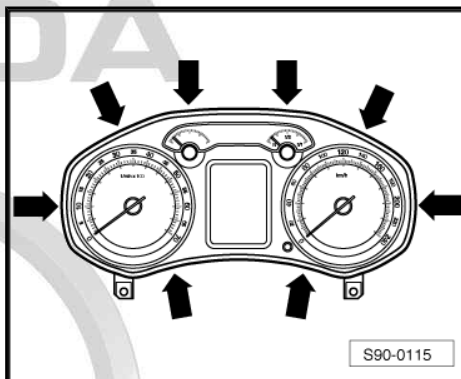

Protected by copyright. Copying for private or commercial purposes, in part or in whole, is not permitted unless authorised by ŠKODA AUTO A. S. ŠKODA AUTO A. S. does not guarantee or accept any liability with respect to the correctness of information in this document. Copyright by ŠKODA AUTO A. S. ©

- Carefully unlatch the shield with transparent washer from the latch clips -arrows-.

All vehicles:

Carefully remove dust and dirt from the new transparent washer and the visible part of the dash panel insert (e.g. by carefully blowing out).

- Make sure the new shield with transparent washer is correctly inserted into the latch clips in the dash panel insert and the reset dowel into the opening of the transparent washer.

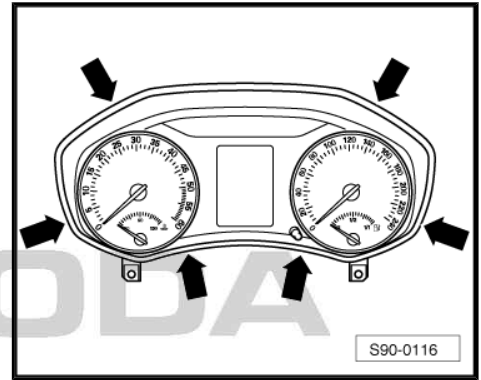

i Note

Before the shield latches fully into position, make sure that all the tabs are correctly inserted, so that the insert frame is not scratched.

Vehicles as of MY 2009:

- Screw in fixing screws -arrows- (0.8 Nm).

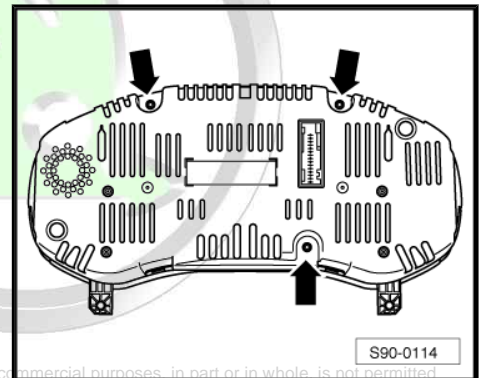

Protected by copyright. Copying for private or commercial purposes, in part or in whole, is not permitted unless authorised by ŠKODA AUTO A. S. ŠKODA AUTO A. S. does not guarantee or accept any liability with respect to the correctness of information in this document. Copyright by ŠKODA AUTO A. S. ©

1.4 Warning light symbols in dash panel insert - vehicles up to MY 08

i Note

- ◆ *The dash panel insert must not be disassembled, only the shield with transparent washer attached with clips is replaceable ⇒ [page 24](#).*
- ◆ *All warning lights are designed as LEDs. The dash panel insert must be replaced if a warning/indicator light breaks down.*
- ◆ *Detailed description of the function of warning lights ⇒ Owner's manual Octavia II.*



- 1 - Diesel particle filter (diesel engine)
- 2 - Immobiliser
- 3 - Left turn signal
- 4 - Coolant temperature/level
- 5 - Brake pad wear
- 6 - Main beam
- 7 - Low beam
- 8 - Rear fog light
- 9 - Washer fluid level
- 10 - Fuel reserve
- 11 - Right turn signal
- 12 - Tyre pressure
- 13 - Automatic gearbox lock
- 14 - Cruise control system
- 15 - Belt warning
- 16 - TCS/ESP
- 17 - Brake malfunction
- 18 - ABS
- 19 - Alternator
- 20 - Oil level
- 21 - Door open
- 22 - Front flap open
- 23 - Engine oil pressure
- 24 - Airbag
- 25 - Power-assisted steering
- 26 - Engine electronics
- 27 - Bulb failure inspection
- 28 - Exhaust gas control system

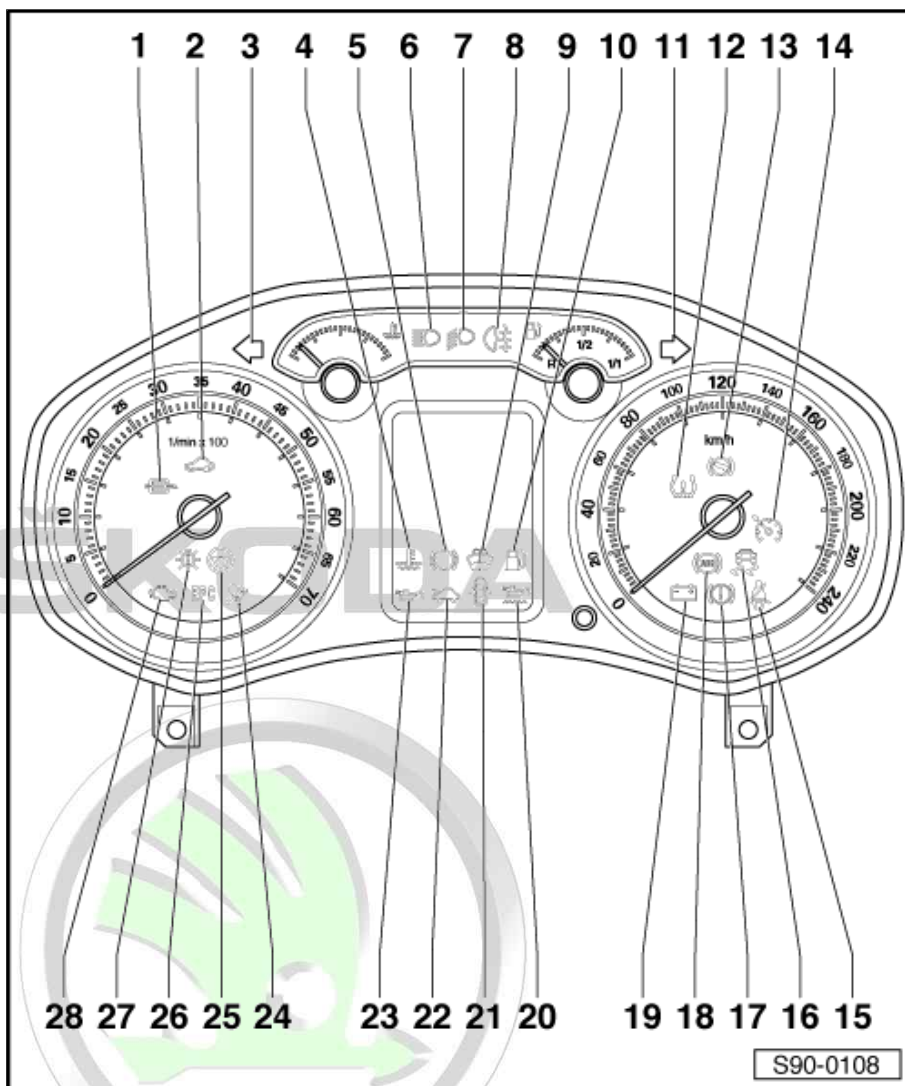

protected by copyright. Copying for private or commercial purposes, in part or in whole, is not permitted unless authorised by ŠKODA AUTO A. S. ŠKODA AUTO A. S. does not guarantee or accept any liability for the correctness of information in this document. Copyright by ŠKODA AUTO A. S. ©

1.5 Warning light symbols in dash panel insert - vehicles as of MY 09



Note

- ◆ *The dash panel insert must not be disassembled, only the shield with transparent washer attached with clips is replaceable ⇒ [page 24](#) .*
- ◆ *All warning lights are designed as LEDs. The dash panel insert must be replaced if a warning/indicator light breaks down.*
- ◆ *Detailed description of the function of warning lights ⇒ Owner's manual Octavia II .*

1 - Diesel particle filter (diesel engine)

2 - Light failure

3 - Airbag

4 - Left turn signal

5 - Fog lights

6 - Main beam

7 - Low beam

8 - Rear fog light

9 - Cruise control system

10 - Right turn signal

11 - ABS

12 - Front flap open

13 - TCS/ESP

14 - Belt warning

15 - Automatic gearbox lock

16 - Tyre pressure

17 - Brake pad wear

18 - Oil level

19 - Fuel reserve

20 - Door open

21 - Alternator

22 - Brake malfunction

23 - Tailgate

24 - Washer fluid level

25 - Glow Plug System (diesel engine), LPG mode (LPG vehicles)

26 - Coolant temperature/level

27 - Engine oil pressure

28 - Power-assisted steering

29 - Exhaust gas control system

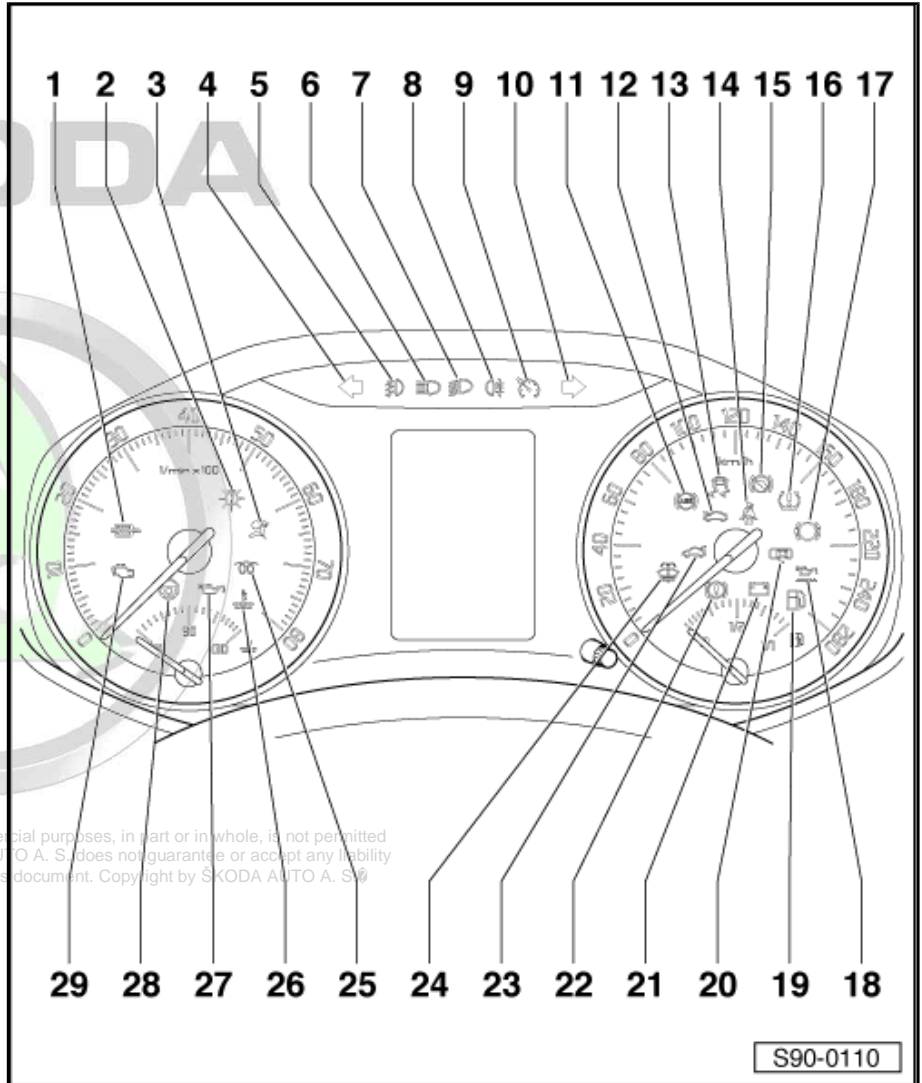

Protected by copyright. Copying for private or commercial purposes, in part or in whole, is not permitted unless authorized by SKODA AUTO A. S. SKODA AUTO A. S. does not guarantee or accept any liability with respect to the correctness of information in this document. Copyright by SKODA AUTO A. S.

1.6 Service interval display

Operation

The electronic control of the service interval display consists of

- ◆ a time counter

and

- ◆ two distance counters.

The electronic control analyses the contents of the counters so that the customer is informed either

- ◆ after a defined period of time has elapsed

or



- ◆ after a defined distance has been reached

by the service interval display that a service is required (depending on what occurs first).

Reset service interval display⇒ Vehicle diagnostic tester

ŠKODA



Protected by copyright. Copying for private or commercial purposes, in part or in whole, is not permitted unless authorised by ŠKODA AUTO A. S. ŠKODA AUTO A. S. does not guarantee or accept any liability with respect to the correctness of information in this document. Copyright by ŠKODA AUTO A. S. ©

2 The self-diagnostic function of the dash panel insert

Initiating self-diagnosis of the dash panel insert

The dash panel insert is controlled by a microprocessor and features a comprehensive self-diagnosis. If faults occur in the system components, fault codes are stored in the event memory of the dash panel insert.

Carry out "self-diagnosis" with the diagnostic unit - VAS 5051- in the function fault finding.

ŠKODA



Protected by copyright. Copying for private or commercial purposes, in part or in whole, is not permitted unless authorised by ŠKODA AUTO A. S. ŠKODA AUTO A. S. does not guarantee or accept any liability with respect to the correctness of information in this document. Copyright by ŠKODA AUTO A. S. ©



91 – Radio, telephone, navigation

1 Radio

⇒ [“1.1 General Instructions”, page 30](#)

⇒ [“1.2 Electronic anti-theft coding”, page 30](#)

⇒ [“1.3 Overview of radio system”, page 31](#)

⇒ [“1.4 Plug connections on the radio”, page 32](#)

⇒ [“1.5 Removing and installing a radio”, page 33](#)

⇒ [“1.6 Self-diagnostic function of radio system”, page 39](#)

1.1 General Instructions



Note

- ◆ *Additional information ⇒ Operating Instruction of the radio .*
- ◆ *When retrofitting equipment, carrying out repair work or fault finding ⇒ Current flow diagrams, Electrical fault finding and Fitting locations and ⇒ Installation instructions for radio .*
- ◆ *Detailed assembly information, e.g. detaching and attaching trim panels ⇒ Body Work; Rep. gr. 70 .*

1.2 Electronic anti-theft coding

The radio system is equipped with Convenience electronic anti-theft lock, which operates in combination with the dash panel insert.

The radio systems are protected with an anti-theft code.

For radio systems mounted at the factory the safety code is only entered in the respective vehicle when it is initial setup. The safety code does no longer have to be re-entered when subsequently disconnecting and re-connecting the battery or when removing and re-installing the radio system in the same vehicle. If the radio system is installed in another vehicle or the dash panel insert is replaced, the safety code must be entered again.

The radio systems in the vehicles are locked at the factory before delivery to the dealers.

Before the vehicle is handed over to the customer, the anti-theft code of the radio must be deactivated by entering a safety code.

The safety code can be read via the online connection with ⇒ Vehicle diagnostic tester (network connection).

The user must have a valid authorisation for the use of a programme to determine the radio coding.

Additional information ⇒ Operating Instruction of the radio .

i Note

- ◆ If an incorrect safety code is entered, it can be corrected immediately at the next attempt. If an incorrect safety code is entered once again, the radio is blocked for 1 hour.
- ◆ After one hour has elapsed, during which the radio as well as the ignition must remain switched on (the time which has elapsed since the lock was activated is shown in the display of the radio), the procedure for deactivating the electronic anti-theft coding can be repeated (always two attempts, then locked for one hour).

1.3 Overview of radio system

i Note

The number and the design of the components depend on the vehicle equipment.

1 - Front treble speaker

- installed next to the front door opening lever
- Removing and installing ⇒ [page 75](#)

2 - Front bass speaker

- installed in door
- Removing and installing ⇒ [page 74](#)

3 - Multimedia socket MEDIA-IN (MDI) with control unit for multimedia system - J650-

- in the storage compartment in the dash panel on the front passenger side
- Removing and installing ⇒ [page 80](#)

4 - Radio

- installed in centre console
- Removing and installing ⇒ [page 33](#)
- Plug connections on the radio ⇒ [page 32](#)

5 - Multi-functional steering wheel

- Description and body work ⇒ [page 61](#)

6 - Connection for external audio sources

- in the centre console in the storage compartment under the armrest of the driver
- Removing and installing ⇒ [page 79](#)

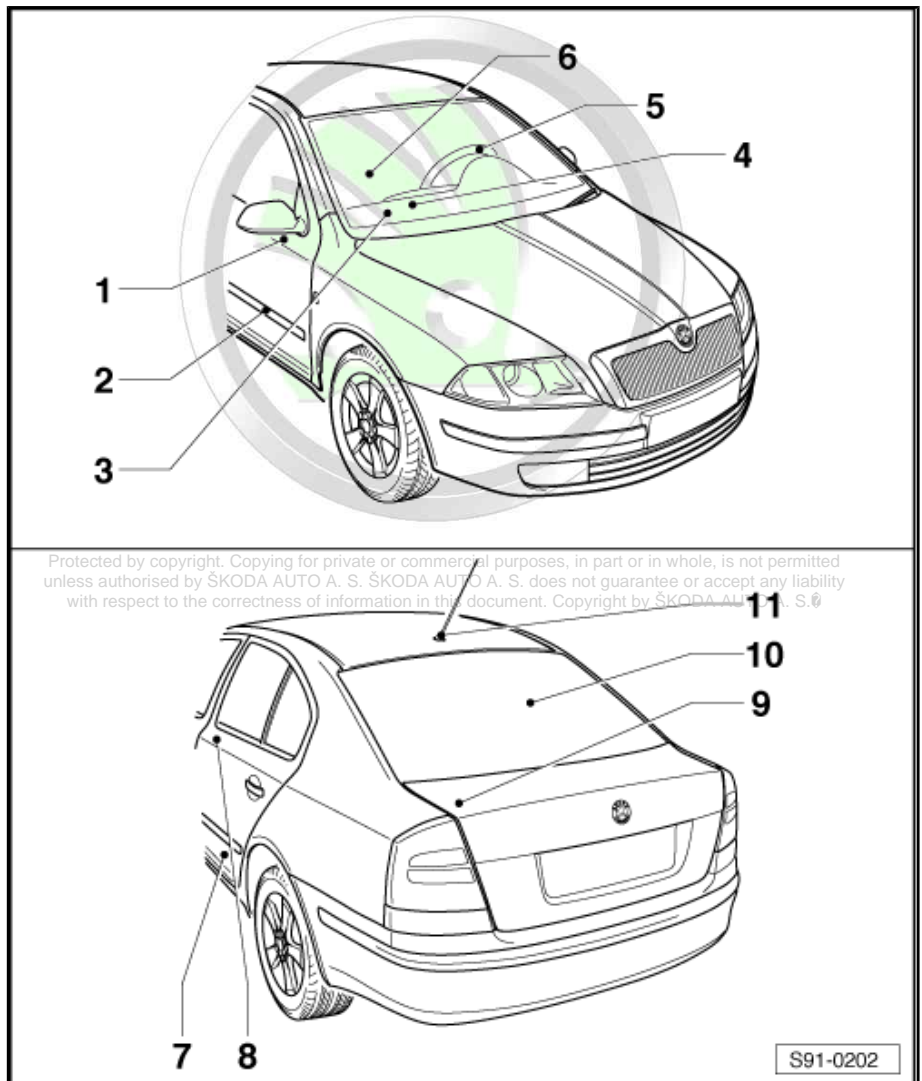

S91-0202



7 - Rear bass speaker

- installed in door
- Removing and installing ⇒ [page 74](#)

8 - Rear treble speaker

- installed next to the rear door handle lever
- Removing and installing ⇒ [page 75](#)

9 - CD changer

- is located in the luggage compartment behind the removable left side trim panel
- Removing and installing ⇒ [page 77](#)
- Contact assignment on the CD changer ⇒ [page 78](#)

10 - Rear window aerial

- Assembly as of CW 01/07 - for radios with two tuners (two antenna sockets)
- fitted in the rear right side window on Octavia Combi
- further information in the chapter aerial systems ⇒ [page 40](#)

11 - Roof aerial

- with aerial amplifier
- Removing and installing ⇒ [page 40](#)
- as of MY 2009 - equipment with mobile phone pre-installation - fin shape

1.4 Plug connections on the radio



Note

- ◆ *The assignment of the stated plug contacts depends upon the vehicle equipment.*
- ◆ *Plug contacts which have not been listed are not used.*



Protected by copyright. Copying for private or commercial purposes, in part or in whole, is not permitted unless authorised by ŠKODA AUTO A. S. ŠKODA AUTO A. S. does not guarantee or accept any liability with respect to the correctness of information in this document. Copyright by ŠKODA AUTO A. S.®

Multipin plug connection -A-, 16-pin, two-piece

- 1 - Speaker + rear right
- 2 - Speaker + front right
- 3 - Speaker + front left
- 4 - Speaker + rear left
- 5 - Speaker - rear right
- 6 - Speaker - front right
- 7 - Speaker - front left
- 8 - Speaker - rear left
- 9 - Convenience system CAN bus (high)
- 10 - Convenience system CAN bus (low)
- 12 - Terminal 31
- 13 - Control signal
- 14 - Outside actuation
- 15 - Terminal 30
- 16 - Terminal 30 - (anti-theft code control signal, "SAFE")

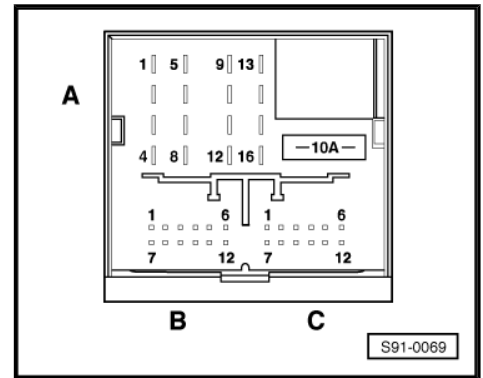

Multipin plug connection -B-, 12-pin

- 1 - AUX/multimedia socket- input, left channel
- 2 - CD changer, audio, earth. As of MY 07 - AUX /multimedia socket - Audio earth
- 3 - As of MY 07 - CD changer, audio earth
- 4 - CD changer/multimedia socket, voltage supply Terminal 30
- 6 - CD changer, DATA output
- 7 - AUX/multimedia socket- input, right channel
- 8 - CD changer, left channel, CD/L
- 9 - CD changer, right channel, CD/R
- 10 - CD changer, control signal
- 11 - CD changer, DATA input
- 12 - CD changer, CLOCK

Multipin plug connection -C-, 12-pin

- 5 - Telephone input signal, L -
- 6 - Telephone input signal, R -
- 11 - Telephone input signal, L +
- 12 - Telephone input signal, R +

1.5 Removing and installing a radio

⇒ ["1.5.1 Radio Stream, Audience", page 34](#)

⇒ ["1.5.2 Radio Melody, Blues", page 35](#)

⇒ ["1.5.3 Radio Swing, Bolero", page 36](#)

⇒ ["1.5.4 Switching off CD drive of radio AUDIENCE", page 38](#)

Protected by copyright. Copying for private or commercial purposes, in part or in whole, is not permitted unless authorised by ŠKODA AUTO A. S. ŠKODA AUTO A. S. does not guarantee or accept any liability with respect to the correctness of information in this document. Copyright by ŠKODA AUTO A. S.



1.5.1 Radio “Stream”, “Audience”

Removing

- Check if there is no CD in the CD drive, if necessary take it out
⇒ Operating instruction of the radio .



Caution

Radio AUDIENCE has a 6 disc CD changer, whose CD drive must be switched off before removing the radio from the vehicle. This avoids any possible damage to the CD drive due to accidental vibrations when handling outside the vehicle interior. Switch off CD drive ⇒ page 38 .

- Switch off radio, the ignition and all electrical components.
- Vehicles with mobile phone holder - slacken mobile phone holder ⇒ page 56 .
- Carefully release the cover frame of the radio using a cross-head screwdriver.
- Unclip the caps -1-.
- Release screws -arrows- (1,5 Nm).
- Pull the radio out of the dash panel.

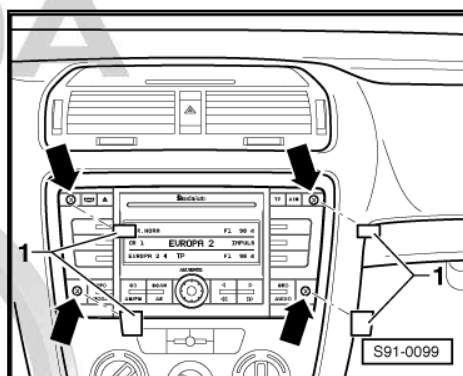

- Compress plug catch -arrows-.

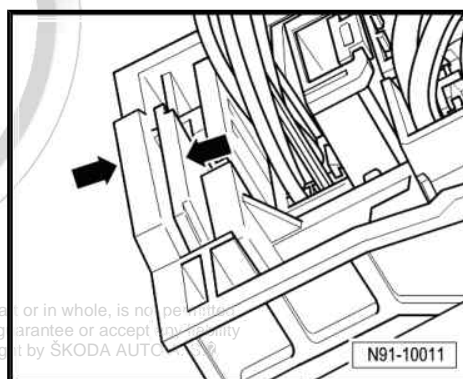

Protected by copyright. Copying for private or commercial purposes, in part or in whole, is not permitted unless authorised by ŠKODA AUTO A. S. ŠKODA AUTO A. S. does not guarantee or accept any liability with respect to the correctness of information in this document. Copyright © ŠKODA AUTO A. S. 2013

- Open catch clamp -arrow- and disconnect plug.

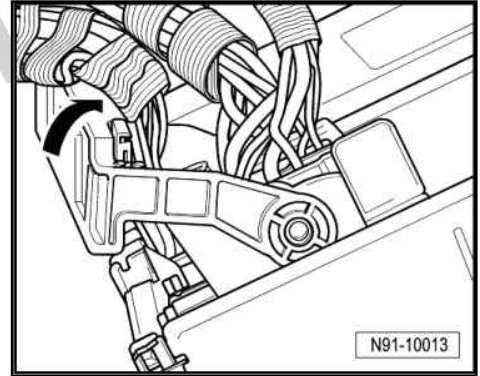

- Release plug of antenna socket -arrow- and disconnect.

Installing

Installation is carried out in the reverse order. When installing, observe the following:



Note

When pushing the radio in, do not in any circumstances press on the display or operating buttons. The radio may be damaged.

If the radio has been replaced:

- Adapt radio by entering the safety code ⇒ [page 30](#) and code ⇒ Vehicle diagnostic tester.

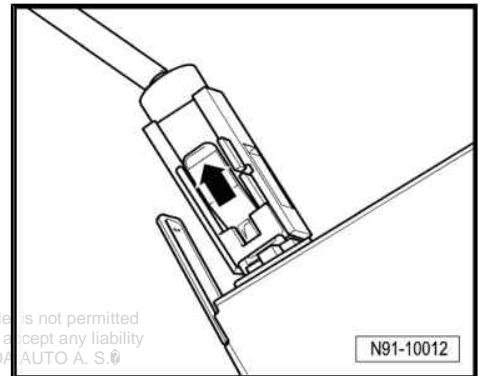

1.5.2 Radio “Melody”, “Blues”

Removing

- Check if there is no cassette/CD in the drive, if necessary take it out ⇒ Operating instruction of the radio .
- Switch off radio, the ignition and all electrical components.
- Vehicles with mobile phone holder - slacken mobile phone holder ⇒ [page 56](#) .
- Carefully release the cover frame of the radio using a cross-head screwdriver.
- Unclip the caps -1-.
- Release screws - 2 - (1,5 Nm).
- Pull the radio out of the dash panel.

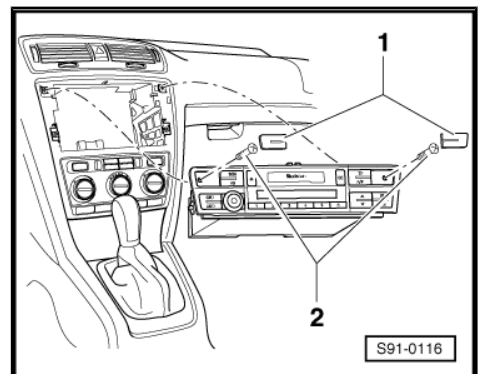

- Compress plug catch -arrows-.

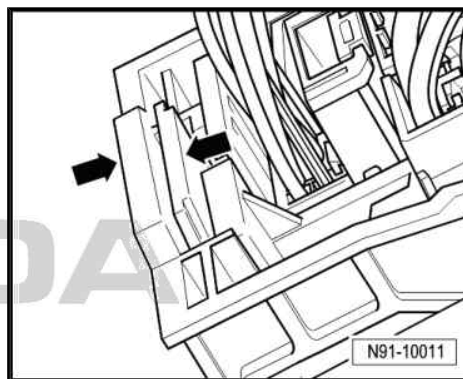

- Open catch clamp -arrow- and disconnect plug.

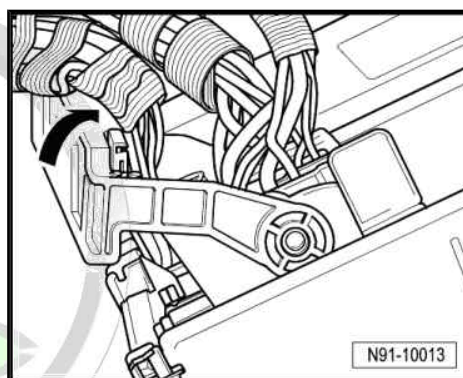

- Release plug of antenna socket -arrow- and disconnect.

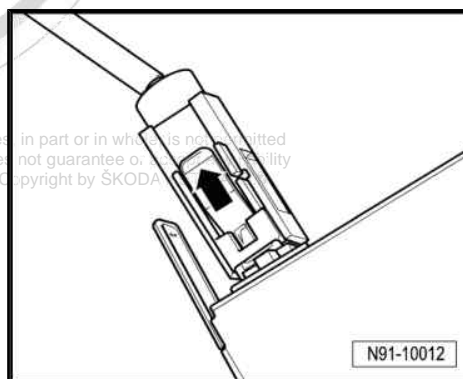

Installing

Installation is carried out in the reverse order. When installing, observe the following:

Protected by copyright. Copying for private or commercial purposes in part or in whole is not permitted unless authorised by ŠKODA AUTO A. S. ŠKODA AUTO A. S. does not guarantee or accept liability with respect to the correctness of information in this document. Copyright by ŠKODA.



Note

When pushing the radio in, do not in any circumstances press on the display or operating buttons. The radio may be damaged.

If the radio has been replaced:

- Adapt radio by entering the safety code ⇒ [page 30](#) and code ⇒ Vehicle diagnostic tester.

1.5.3 Radio “Swing”, “Bolero”

Removing

- Check if there is no CD in the CD drive, if necessary take it out ⇒ Operating instruction of the radio .



Note

Radio Bolero has a 6 disc CD changer. After removing the last CD, the CD drive is automatically switched off to protect it against damage due to possible vibrations outside the vehicle cockpit.

- Switch off radio, the ignition and all electrical components.
- Vehicles with mobile phone holder - slacken mobile phone holder ⇒ [page 56](#) .
- Remove radio cover frame and heating/air conditioning system control using a disassembly wedge - 3409- .

- Then carefully slacken the upper cover of the radio -3-.
- Screw out the fixing screws -2- (1.5 Nm) and pull the radio -1- out of the dash panel.

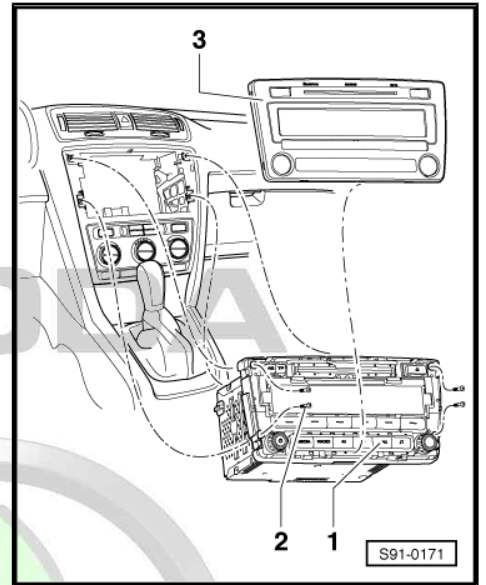

- Compress plug catch -arrows-.

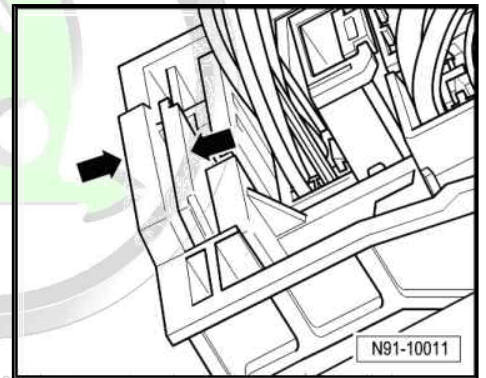

- Open catch clamp -arrow- and disconnect plug

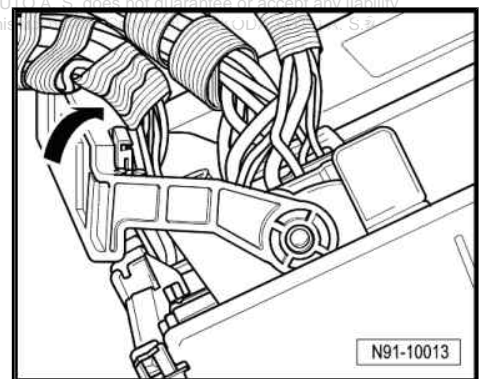

Protected by copyright. Copying for private or commercial use without the written permission of SKODA AUTO A. S. SKODA AUTO A. S. does not guarantee or accept any liability for the correctness of information in this manual.

- Release plug of antenna socket -arrows- and disconnect.

Installing

Installation is carried out in the reverse order. When installing, observe the following:



Note

When pushing the radio in, do not in any circumstances press on the display or operating buttons. The radio may be damaged.

If the radio has been replaced:

- Adapt radio by entering the safety code => [page 30](#) and code => Vehicle diagnostic tester.

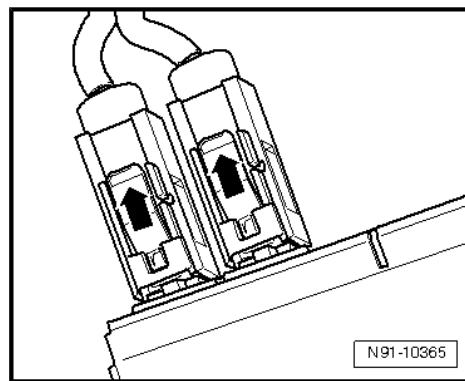

1.5.4 Switching off CD drive of radio AUDI-ENCE

It is carried out before removing the radio from the vehicle.

Work procedure

- Withdraw ignition key and switch on the radio with the rotary knob.
- Press the "EJECT" button to make sure the changer is empty (all positions NO CD) - see => Operating instructions of radio .
- Press both buttons marked with simple arrow -Fig.- and hold for approx. 2 seconds. After the display "SYSTEM DEBUG" (see the last fig.), release the buttons.

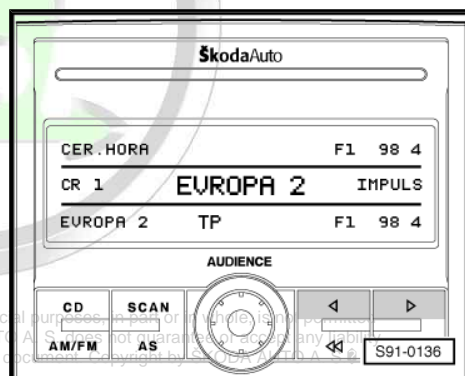

- Select the field "HARDWARE" with the pre-selection button -fig.-. By actuating this button switch over to the next display.

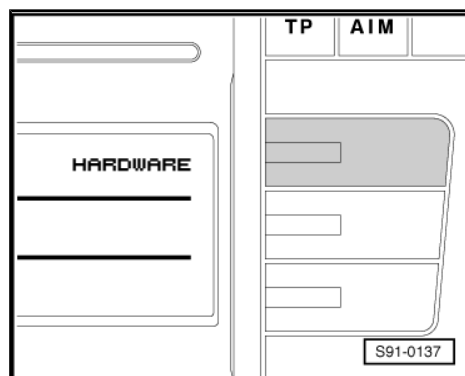

- Press the pre-selection button "CD TRANS" - fig. - in this display, in order to send the command for switching off the drive. A gong may come from the speakers which confirms that the command has been sent.
- Afterwards, press the button "BACK" button -fig-.

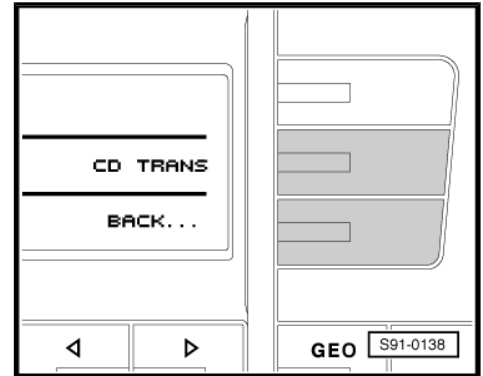

- Once again "SYSTEM DEBUG" -fig-. appears in the display by operating the button "BACK"
- The radio goes back to the standard display of the FM station after approx. 10 seconds, see the -first illustration- (this display can differ depending on the stored pre-selections).
- Switch off the radio with the rotary knob. The drive is switched off, when everything was carried out correctly.

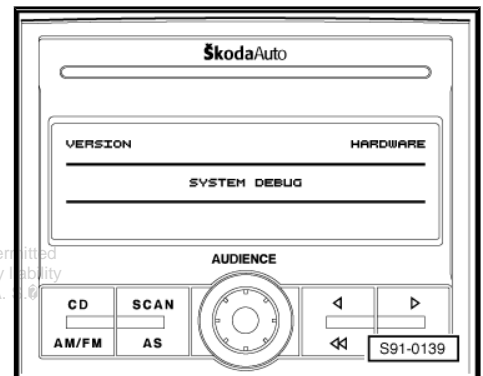

We recommend to listen carefully to the drive, as similar noises can be heard when switching off the CD drive as for the CD changer.

- The radio is ready to be taken out when all noises are eliminated.

Note

All radios "AUDIENCE" are supplied as replacement part with CD drive in the deactivated state. When connecting the radio to the vehicle voltage the drive is automatically initialised when pressing the rotary knob for the first time. Therefore the operating mode cannot be activated.

1.6 Self-diagnostic function of radio system

Carry out "self-diagnosis" with the ⇒ Vehicle diagnostic tester in the function "Targeted fault finding".

2 Aerial systems

- ⇒ [“2.1 Overview of the aerial systems”, page 40](#)
- ⇒ [“2.2 Removing and installing aerial module R108”, page 41](#)
- ⇒ [“2.3 Roof aerial for radio”, page 42](#)
- ⇒ [“2.4 Roof aerial for operating the radio and mobile phone”, page 43](#)
- ⇒ [“2.5 Roof aerial for radio, telephone and navigation system - vehicles up to MY 08”, page 44](#)
- ⇒ [“2.6 Roof aerial for radio, telephone and navigation system - vehicles as of MY 09”, page 44](#)

2.1 Overview of the aerial systems



Note

The number of components of the aerial system depends on the vehicle equipment and on the model year.

Protected by copyright. Copying for private or commercial purposes, in part or in whole, is not permitted unless authorized by SKODA AUTO A. S. SKODA AUTO A. S. does not guarantee or accept any liability with respect to the correctness of information in this document. Copyright by SKODA AUTO A. S. ©

1 - Control unit for the mobile phone operating electronics - J412-

- As of CW 22.11, a Bluetooth module is integrated in the navigation system Amundsen+ which fulfills the function of the GSM II mobile phone pre-installation. The control unit for the mobile phone operating electronics - J412- is not available for this equipment. The control unit for the mobile phone operating electronics - J412- Pos. -1- is still installed separately for the GSM III mobile phone pre-installation.
- Removing and installing ⇒ [page 54](#)

2 - Mount for mobile phone

- Removing and installing ⇒ [page 57](#)

3 - Radio/navigation system

4 - Frequency filter for the frequency modulation (FM) in the positive cable - R179-

- installed in the wiring harness
- only on vehicles with rear window aerial

5 - Aerial module - R108- (amplifier)

- Octavia- under the rear window on the right

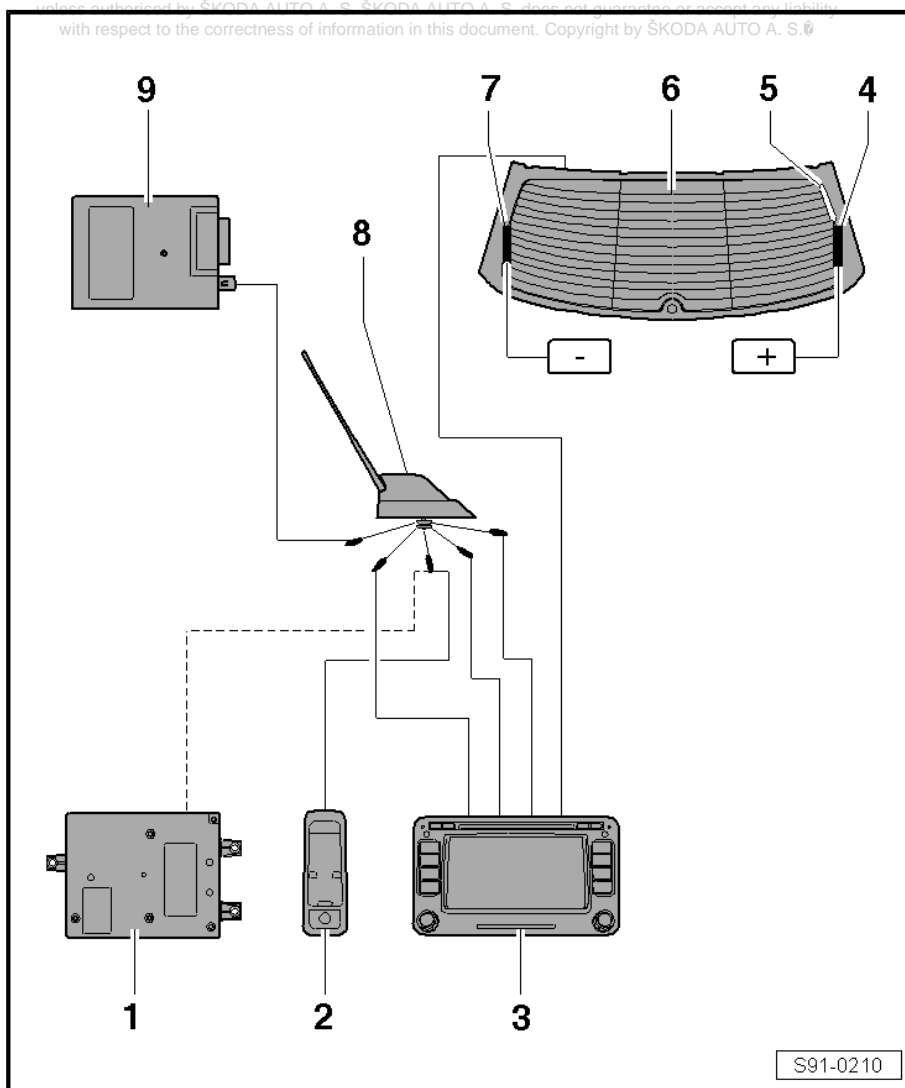

S91-0210

- Octavia Combi - under the top trim panel of the right C pillar
- Removing and installing ⇒ [page 41](#)

6 - Rear window aerial - R130-

- Assembly as of CW 01/07 - for radios with two tuners (two antenna sockets)
- fitted in the rear right window on "Combi" vehicles

7 - Frequency filter for the frequency modulation (FM) in the negative cable - R178-

- installed in the wiring harness
- only on vehicles with rear window aerial

8 - Roof aerial

- different in shape depending on the model year and equipment

9 - Auxiliary heating radio controlled receiver - R64-

- removing and installing ⇒ Heating, Air Conditioning; Rep. gr. 82

2.2 Removing and installing aerial module - R108-

Remove - Octavia

- Remove rear window ⇒ Body work; Rep. gr. 64 .



Note

Proceed carefully when removing the rear window so that the cable to the aerial module does not pull off. Before removing the window, carefully disconnect the plug from the aerial module.

- Remove right luggage compartment trim panel ⇒ Body Work; Rep. gr. 70 .
- Unscrew fixing screw -arrow- (1.5 Nm).

Protected by copyright. Copying for private or commercial purposes, in part or in whole, is not permitted unless authorised by ŠKODA AUTO A. S. ŠKODA AUTO A. S. does not guarantee or accept any liability with respect to the correctness of information in this document. Copyright by ŠKODA AUTO A. S. ©

- Move aerial module -arrow- and unhook from the bracket.
- Expose the cable of the aerial module to the plug connection under the right luggage compartment trim panel and remove the aerial module with the cable.

Remove - Octavia Combi

- Remove top right trim panel of pillar C ⇒ Body Work; Rep. gr. 70 .

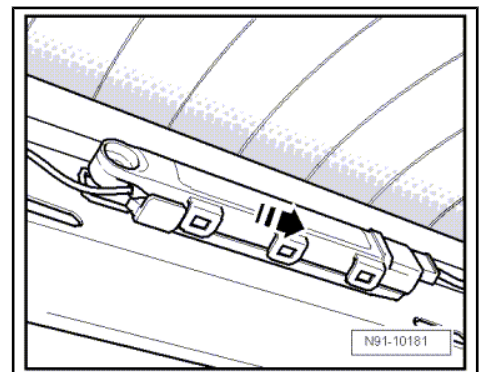
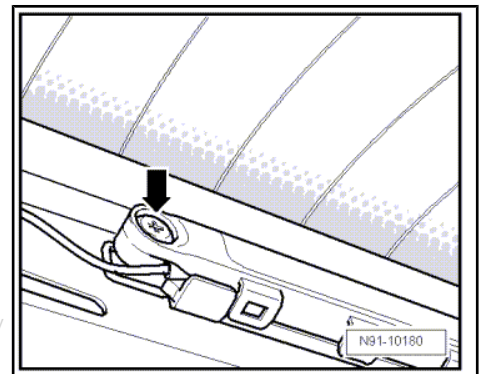

- Carefully disconnect the plug -3- from above.
- Depending on the type of module - disconnect the antenna socket from the bottom -5- of the aerial module -4-, if necessary slacken the cable and disconnect the antenna socket below the luggage compartment trim panel (approx. 40 cm from the aerial module -4-).
- Unscrew screw -2- (1.5 Nm), move aerial module -4- and unhook from bracket at pillar -1-.

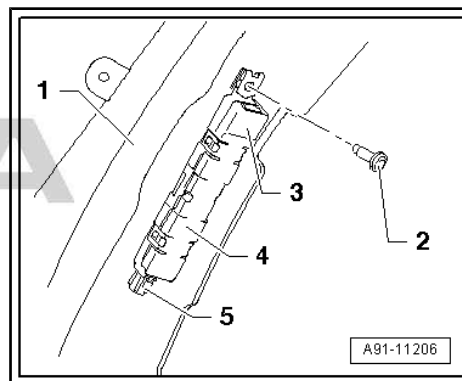

Installing

The installation occurs in reverse order.

2.3 Roof aerial for radio

1 - Aerial rod

- the aerial rod can be removed or folded depending on the type of aerial - combined with the aerial base

2 - Aerial base

- for removal and installation: lower the rear moldliner

3 - Connection for the antenna cable going to the radio

4 - Hexagon nut with serrated washer

- Vehicles up to MY 08 - 3 + 1 Nm
- Vehicles as of MY 09 - 6 + 1 Nm
- hexagonal nut is connected to serrated washer by a plastic ring
- apply contact grease on the inside of roof in the area of the serrated washer

5 - Roof

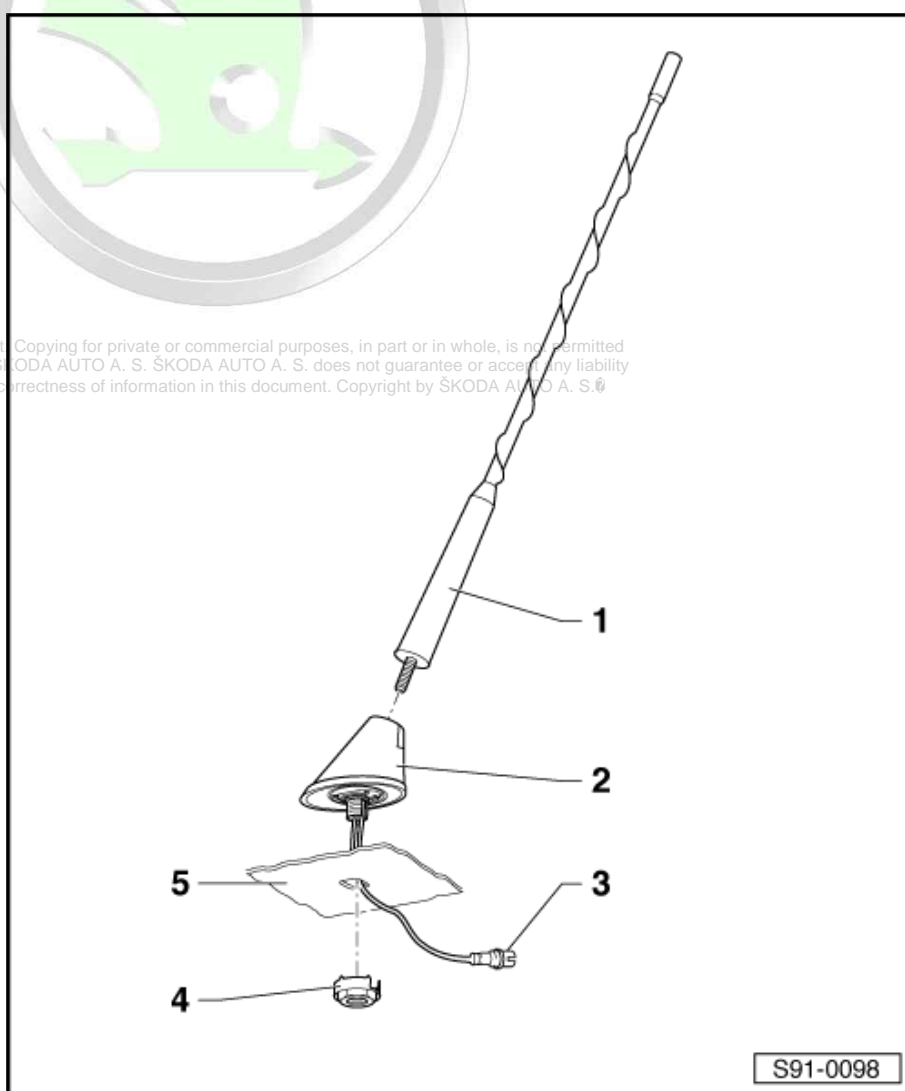

2.4 Roof aerial for operating the radio and mobile phone

1 - Aerial base with aerial rod

- the aerial rod can be removed or folded depending on the type of aerial - combined with the aerial base
- do not let the aerial rod remain screwed out
- Amplifier for roof aerial is installed in base of aerial
- for removal and installation: lower the rear moldliner

2 - Connection for the antenna cable going to the radio

3 - Connection for the antenna cable of the mobile phone pre-installation and telephone system

4 - Hexagon nut with serrated washer

- Vehicles up to MY 08 - 3 + 1 Nm
- Vehicles as of MY 09 - 6 + 1 Nm
- hexagonal nut is connected to serrated washer by a plastic ring
- apply contact grease on the inside of roof in the area of the serrated washer

5 - Roof

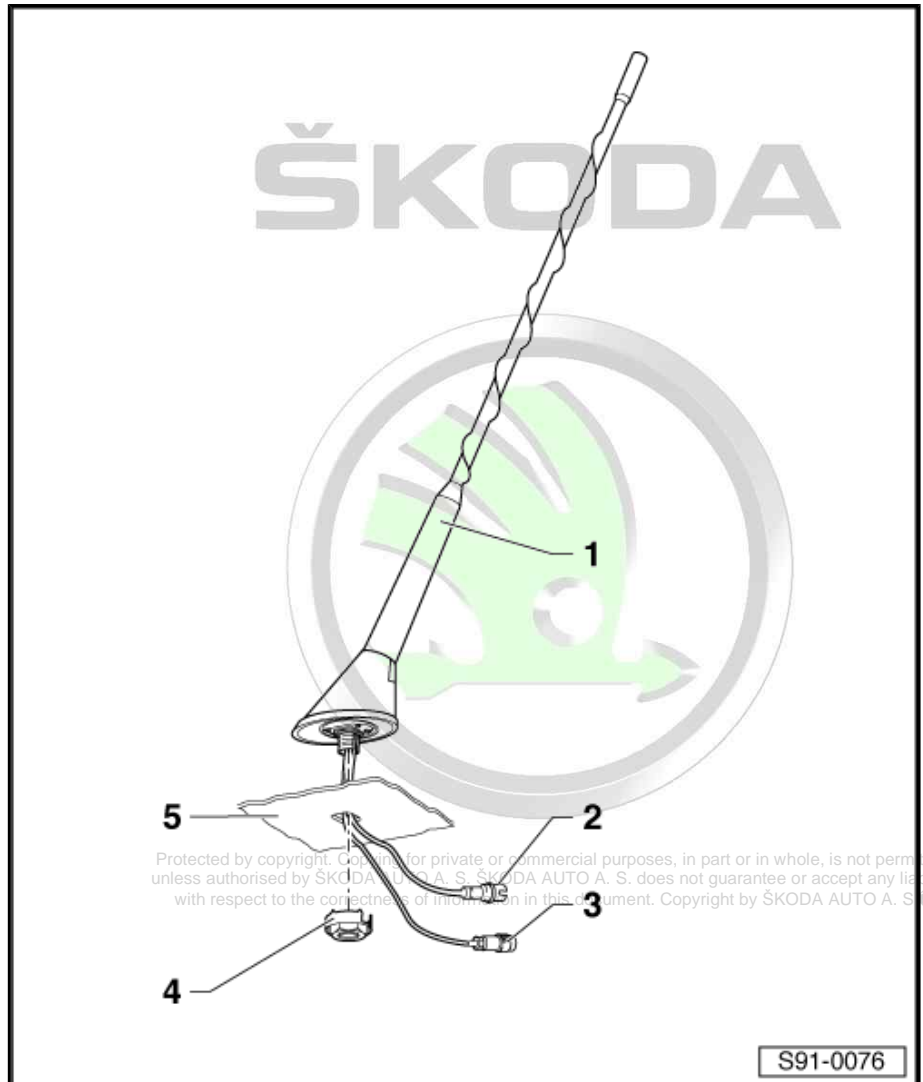

2.5 Roof aerial for radio, telephone and navigation system - vehicles up to MY 08

1 - Aerial base with aerial rod

- the aerial rod can be removed or folded depending on the type of aerial - combined with the aerial base
- do not let the aerial rod remain screwed out
- Amplifier for roof aerial is installed in base of aerial
- To remove and install:
lower rear headliner ⇒
Body Work; Rep. gr. 70

2 - Connection for the antenna cable going to the navigation

- ⇒ [page 47](#)

3 - Connection for the antenna cable going to the radio

4 - Connection for the antenna cable of the mobile phone pre-installation and telephone system

5 - Hexagon nut with serrated washer

- 3 Nm
- hexagonal nut is connected to serrated washer by a plastic ring
- apply contact grease on the inside of roof in the area of the serrated washer

6 - Roof

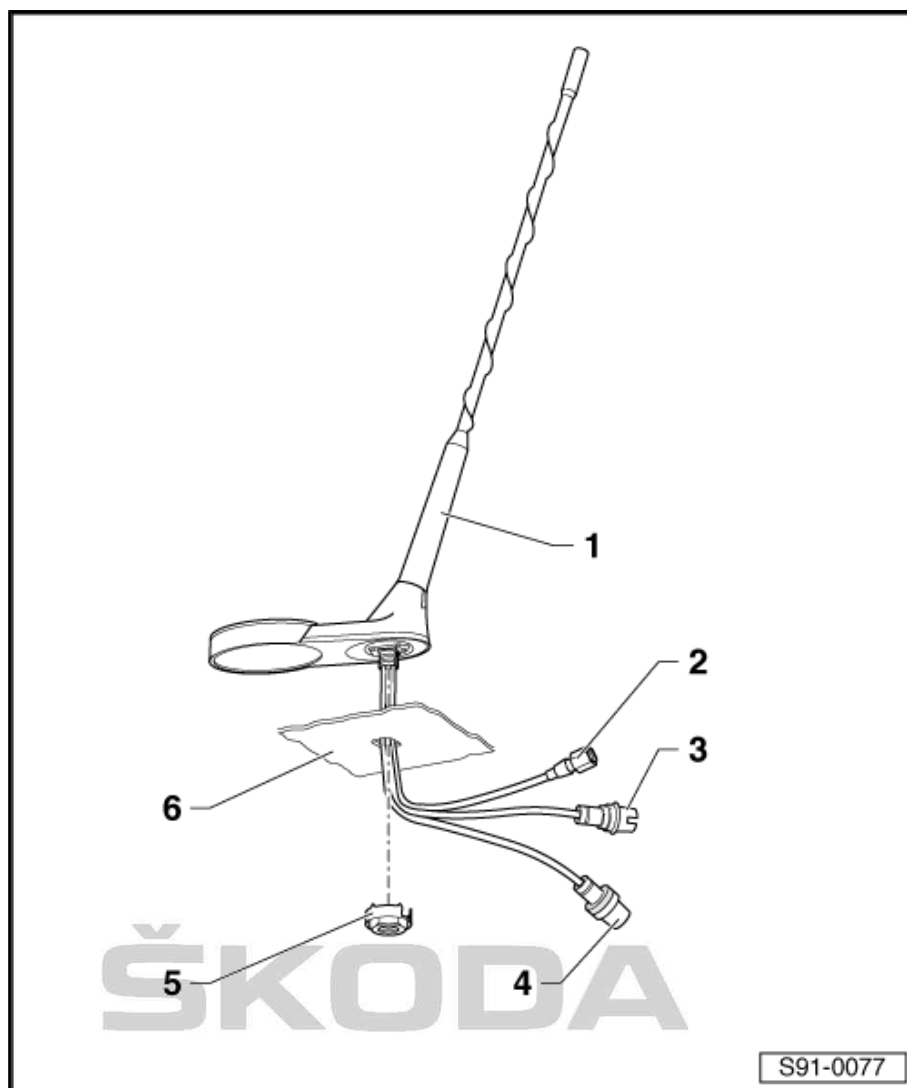

S91-0077

2.6 Roof aerial for radio, telephone and navigation system - vehicles as of MY 09



Note

The number of connections of the aerial base depends on the vehicle equipment.

⇒ ["2.6.1 Octavia", page 45](#)

⇒ ["2.6.2 Octavia Combi", page 46](#)

2.6.1 Octavia

1 - Aerial rod

- can be removed

2 - Aerial base with integrated amplifier

- To remove and install:
lower rear headliner =>
Body Work; Rep. gr. 70

3 - Hexagon nut with serrated washer

- 6 + 1 Nm
- hexagonal nut is connected to serrated washer by a plastic ring
- apply contact grease on the inside of roof in the area of the serrated washer

4 - Aerial cable to radio

- White plug

5 - Aerial cable to telephone

- Lilac plug

6 - Aerial cable to navigation

- Blue plug

7 - Aerial cable to Telestart (operation of the auxiliary heating)

- Beige plug

8 - Aerial cable to radio

- black plug
- Reception of digital programme

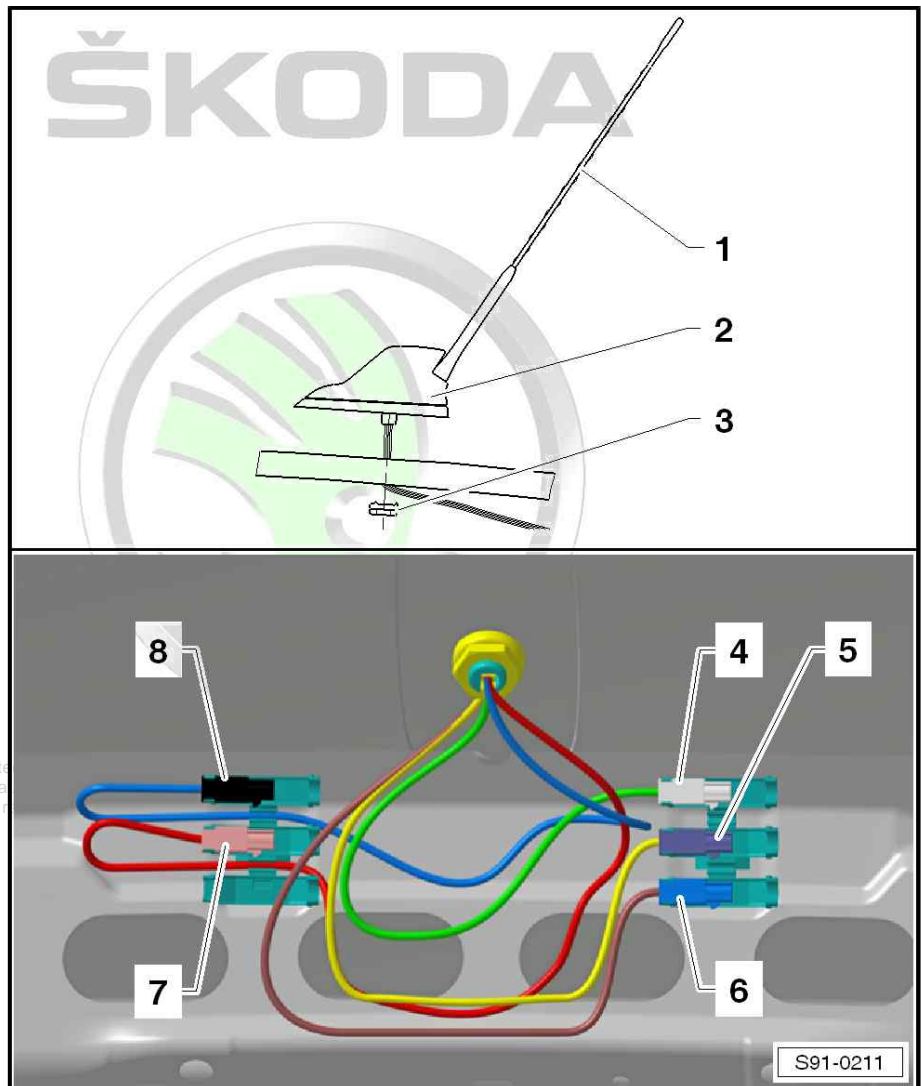



2.6.2 Octavia Combi

1 - Aerial rod

- can be removed

2 - Aerial base with integrated amplifier

- To remove and install:
lower rear headliner ⇒
Body Work; Rep. gr. 70

3 - Hexagon nut with serrated washer

- 6 + 1 Nm
- hexagonal nut is connected to serrated washer by a plastic ring
- apply contact grease on the inside of roof in the area of the serrated washer

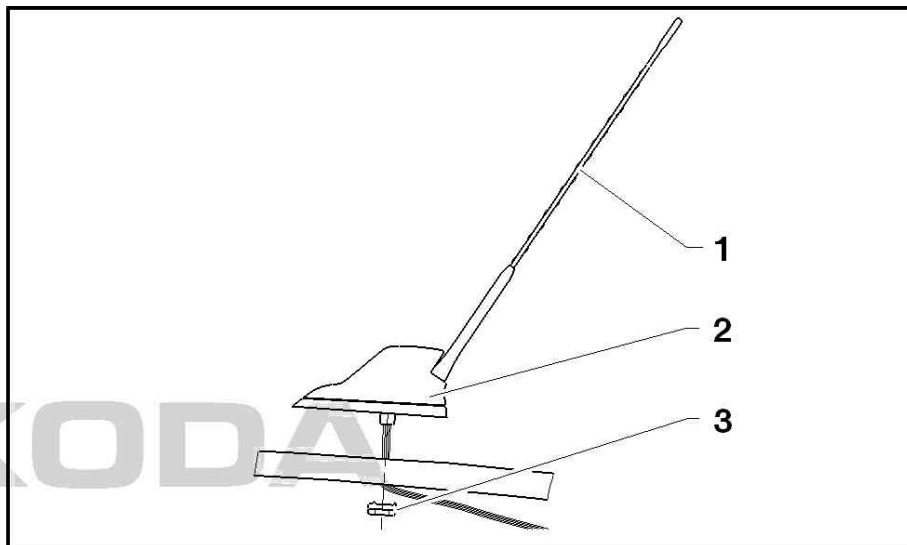

4 - Aerial cable to Telestart (operation of the auxiliary heating)

- Beige plug

5 - Aerial cable to telephone

- Lilac plug

6 - Aerial cable to radio

- White plug

7 - Aerial cable to radio

- black plug
- Reception of digital programme

8 - Aerial cable to navigation

- Blue plug

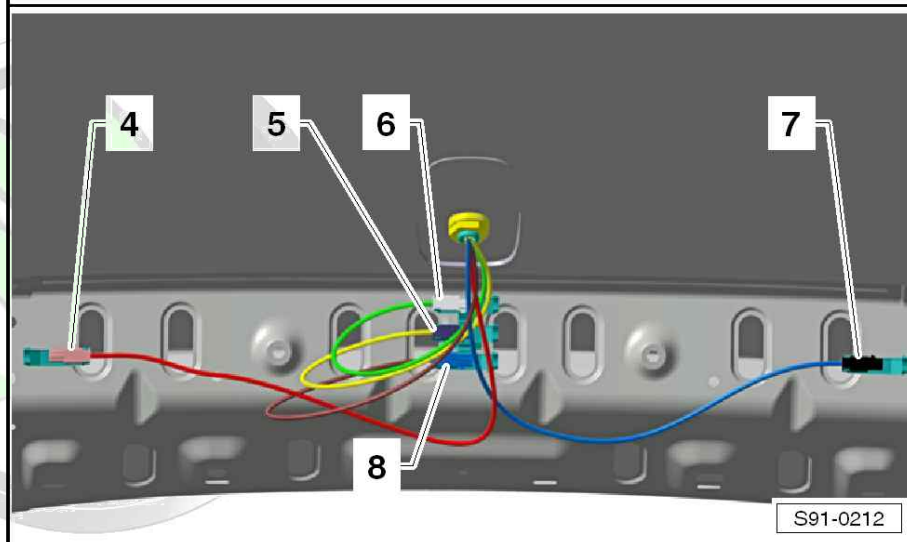

Protected by copyright. Copying for private or commercial purposes, in part or in whole, is not permitted unless authorised by ŠKODA AUTO A. S. ŠKODA AUTO A. S. does not guarantee or accept any liability with respect to the correctness of information in this document. Copyright by ŠKODA AUTO A. S.®

S91-0212



3 Navigation system

⇒ [“3.1 General description”, page 47](#)

⇒ [“3.2 General Instructions”, page 48](#)

⇒ [“3.3 Electronic anti-theft coding”, page 48](#)

⇒ [“3.4 Overall view of the navigation system”, page 49](#)

⇒ [“3.5 Plug connections on the navigation system”, page 50](#)

⇒ [“3.6 Removing and installing the navigation system”, page 52](#)

⇒ [“3.7 Self-diagnosis of the navigation system”, page 53](#)

3.1 General description

The navigation system combines the functions of the radio, CD (Cruise, Nexus, Amundsen) /DVD (Columbus) player and navigation system.

The double DIN housing of the system contains:

- ◆ an RDS radio
- ◆ Control unit for traffic information for the reception of traffic information
- ◆ black and white (monochromatic) or colour display
- ◆ a navigation system with GPS satellite receiver
- ◆ Cruise, Nexus, Amundsen - CD drive for navigation system with possibility to play audio discs
- ◆ Columbus - DVD drive for navigation system with the possibility to play audio/video discs
- ◆ As of CW 22.11 - a Bluetooth module is integrated in the navigation system Amundsen+ which fulfills the function of the GSM II mobile phone pre-installation (the control unit for the mobile phone operating electronics - J412- that is located under the right seat is no longer fitted). The control unit for the mobile phone operating electronics - J412- remains under the right seat for the GSM III mobile phone pre-installation.

The system can be retrofitted with an external CD changer.

Further information and description of function:

- ◆ ⇒ Self-study programme No. 61 ; Radio navigation system in Skoda vehicles
- ◆ ⇒ Operating instruction of the navigation system



3.2 General Instructions



Note

- ◆ *When handling a fault it is absolutely essential to know the functions and the operation of the navigation system.*
- ◆ *Additional information ⇒ Operating instruction of the navigation system .*
- ◆ *When retrofitting equipment, carrying out repair work or fault finding ⇒ Current flow diagrams, Electrical fault finding and Fitting locations and ⇒ Installation instruction for navigation system .*
- ◆ *Detailed assembly information, e.g. detaching and attaching trim panels ⇒ Body Work; Rep. gr. 70 .*

3.3 Electronic anti-theft coding

The navigation system is equipped with Convenience electronic anti-theft lock, which operates in combination with the dash panel insert.

Protected by copyright. Copying for private or commercial purposes, in part or in whole, is not permitted unless authorised by SKODA AUTO A. S. SKODA AUTO A. S. does not guarantee or accept any liability with respect to the correctness of information in this document. Copyright by SKODA AUTO A. S. ©

The navigation systems are protected against theft with a safety code.

For navigation systems mounted at the factory, the safety code is only entered in the respective vehicle when it is initial setup. The safety code does no longer have to be re-entered when subsequently disconnecting and re-connecting the battery or when removing and re-installing the unit in the same vehicle. If the navigation system is installed in another vehicle or the dash panel insert is replaced, the safety code must be entered again.

The navigation systems in the vehicles are locked at the factory before delivery to the dealers.

Before the vehicle is handed over to the customer, the anti-theft code of the navigation system must be deactivated by entering a safety code.

The safety code can be read via the online connection with ⇒ Vehicle diagnostic tester (network connection).

The user must have a valid authorisation for the use of a programme to determine the coding of the navigation system.

Additional information ⇒ Operating instruction of the navigation system .



Note

- ◆ *If an incorrect safety code is entered, it can be corrected immediately at the next attempt. If an incorrect safety code is entered once again, the navigation system is blocked for 1 hour.*
- ◆ *After one hour has elapsed, during which the navigation system as well as the ignition must remain switched on (the time which has elapsed since the lock was activated is shown in the display of the navigation system), the procedure for deactivating the electronic anti-theft coding can be repeated (always two attempts, then locked for one hour).*

3.4 Overall view of the navigation system

i Note

The number and the design of the components depend on the vehicle equipment and on the model year.

1 - Front treble speaker

- installed next to the front door opening lever
- Removing and installing ⇒ [page 75](#)

2 - Front bass speaker

- installed in door
- Removing and installing ⇒ [page 74](#)

3 - Multimedia socket MEDIA-IN (MDI) with control unit for multimedia system - J650-

- in the storage compartment in the dash panel on the front passenger side
- Removing and installing ⇒ [page 80](#)

4 - Navigation system

- installed in centre console
- Removing and installing ⇒ [page 52](#)
- Plug connections on the navigation system ⇒ [page 50](#)

5 - Multi-functional steering wheel

- Description and body work ⇒ [page 61](#)

6 - Connection for external audio sources

- in the centre console in the storage compartment under the armrest of the driver
- Removing and installing ⇒ [page 79](#)

7 - Rear bass speaker

- installed in door
- Removing and installing ⇒ [page 74](#)

8 - Rear treble speaker

- installed next to the rear door handle lever
- Removing and installing ⇒ [page 75](#)

9 - CD changer

- is located in the luggage compartment behind the removable left side trim panel
- Removing and installing ⇒ [page 77](#)
- Contact assignment on the CD changer ⇒ [page 78](#)

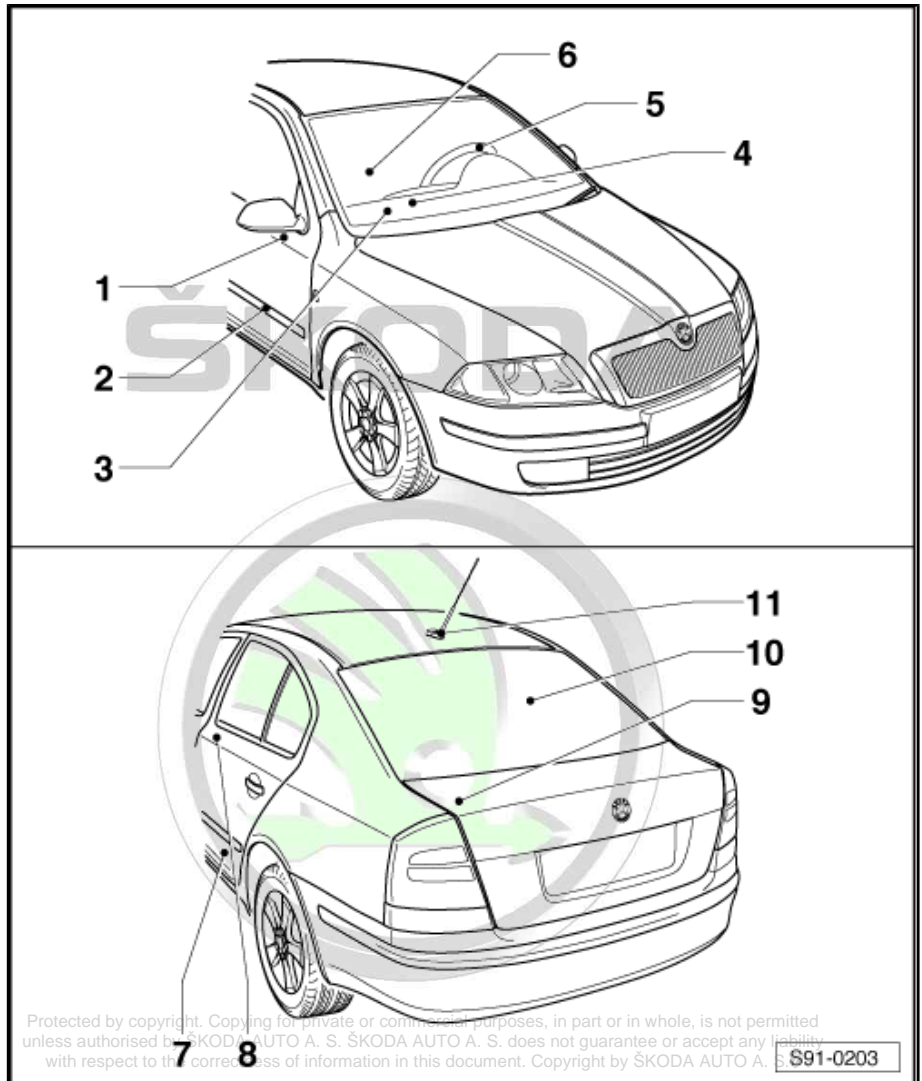

10 - Rear window aerial

- Assembly as of CW 01/07 - for navigation systems with two tuners (two antenna sockets)
- fitted in the rear right side window on Octavia Combi
- further information in the chapter aerial systems ⇒ [page 40](#)

11 - Roof aerial

- with aerial amplifier
- Removing and installing ⇒ [page 40](#)
- as of MY 2009 - fin shape

3.5 Plug connections on the navigation system



Note

- ◆ *The assignment of the stated plug and plug contacts depends upon the vehicle equipment.*
- ◆ *Plug contacts which have not been listed are not used.*

1 - Plug connection of the aerial for the reception of the digital programme (DAB)

- optionally

2 - 8-pin plug -A-

3 - 8-pin plug -D-

4 - 12-pin plug -C-

5 - 12-pin plug -B-

6 - 26-pin connector

- Amundsen+ - UHV II

7 - Aerial contact connection for GPS navigation

8 - Aerial contact connection for the radio reception FM

9 - Aerial contact connection for the radio reception AM and FM

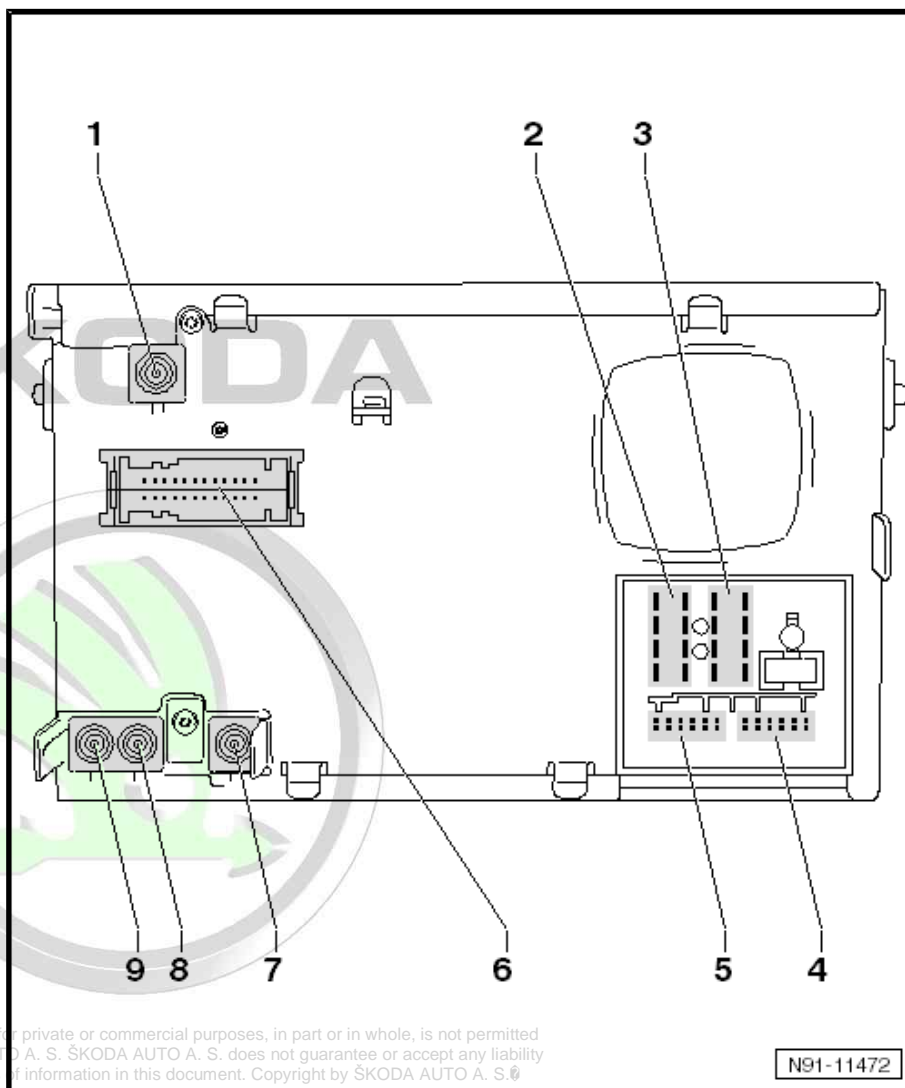

Protected by copyright. Copying for private or commercial purposes, in part or in whole, is not permitted unless authorised by ŠKODA AUTO A. S. ŠKODA AUTO A. S. does not guarantee or accept any liability with respect to the correctness of information in this document. Copyright by ŠKODA AUTO A. S. ©

N91-11472

Multipin plug connection -A-, 8-pin, two-piece

- 1 - Speaker + rear right
- 2 - Speaker + front right
- 3 - Speaker + front left
- 4 - Speaker + rear left
- 5 - Speaker - rear right
- 6 - Speaker - front right
- 7 - Speaker - front left
- 8 - Speaker - rear left

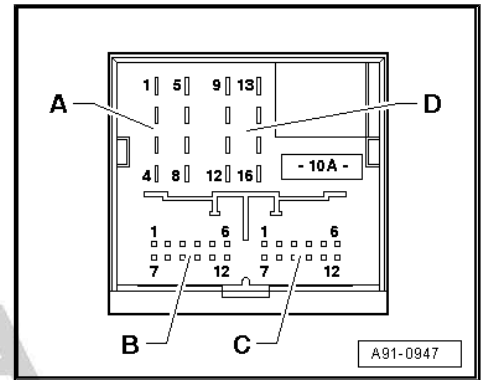

Multipin plug connection -B-, 12-pin

- 1 - AUX/multimedia socket- input, left channel
- 2 - CD changer, audio, earth. As of MY 07 - AUX /multimedia socket - Audio earth
- 3 - As of MY 07 - CD changer, audio earth
- 4 - CD changer/multimedia socket, voltage supply Terminal 30
- 7 - AUX/multimedia socket- input, right channel
- 6 - CD changer, DATA OUT
- 8 - CD changer, left channel, CD/L
- 9 - CD changer, right channel, CD/R
- 10 - CD changer, control signal
- 11 - CD changer, DATA IN
- 12 - CD changer, CLOCK

Multipin plug connection -C-, 12-pin

- 5 - Input signal Audio -
- 6 - Telephone input signal, TEL -
- 11 - Input signal Audio +
- 12 - Telephone input signal, TEL +

Multi-pin plug connection -D-, 8-pin

- 9 - Convenience system CAN bus (high)
- 10 - Convenience system CAN bus (low)
- 11 - Mute (telephone mode)
- 12 - Terminal 31
- 13 - Control signal
- 14 - Outside actuation
- 15 - Terminal 30
- 16 - Terminal 30 - (anti-theft code control signal, "SAFE")

Protected by copyright. Copying for private or commercial purposes, in part or in whole, is not permitted without the prior written permission of ŠKODA AUTO A. S. ŠKODA AUTO A. S. does not guarantee or accept any liability with respect to the correctness of information in this document. Copyright by ŠKODA AUTO A. S.

26-pin connector

- 6 - UHV - mobile phone detection
- 7 - UHV - data processing
- 8 - Diagnostic antenna
- 19 - UHV - negative
- 20 - UHV - positive, terminal 30

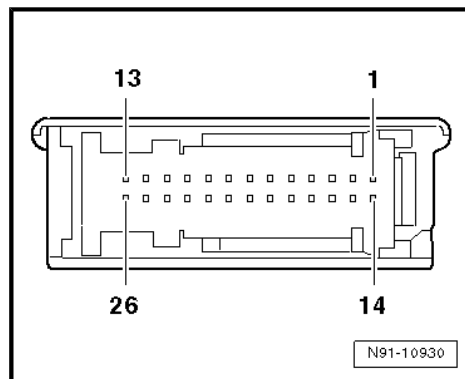

3.6 Removing and installing the navigation system



Note

The part number can be found on the sticker affixed to the housing of the navigation system.

Removing

- Switch off the navigation system, the ignition and all electrical consumers.
- Vehicles with mobile phone holder - slacken mobile phone holder ⇒ [page 56](#) .
- Carefully release the cover frame of the navigation system and the heater control using a cross-head screwdriver.
- Release screws -arrows- (1,5 Nm).
- Pull the navigation system out of the dash panel.

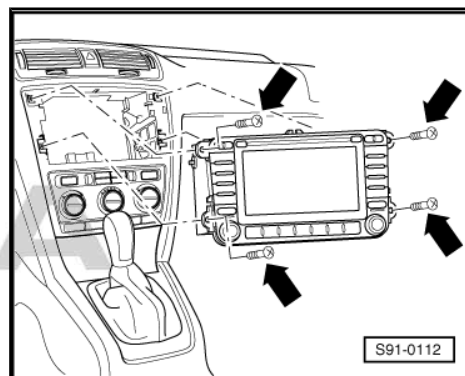

- Compress plug catch -arrows-.

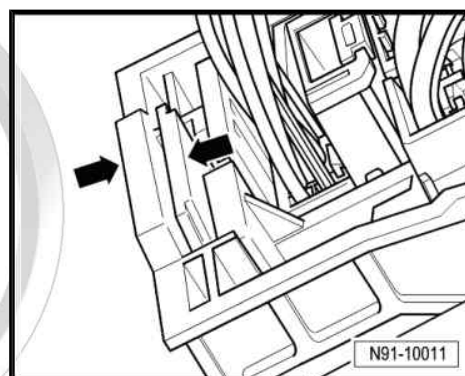

- Open catch clamp -arrow- and disconnect plug.

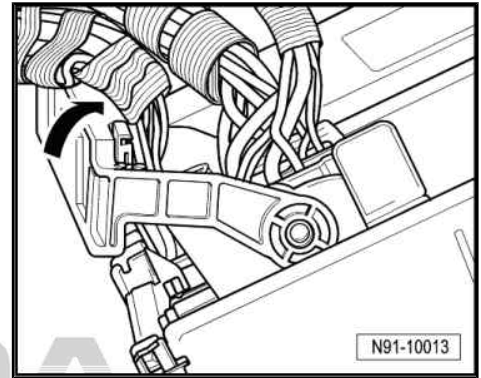

- Release plug of antenna socket -arrows- and disconnect.
- Disconnect the plug for the mobile phone pre-installation (Amundsen+ as of CW 22.11 with the GSM II mobile phone pre-installation and mobile phone holder).

Installing

Installation is carried out in the reverse order. When installing, observe the following:



When inserting the navigation system on no account press on the display or on the buttons otherwise they will be damaged.

- If the navigation system was replaced, an adaptation must be performed by entering the safety code ⇒ [page 48](#) and code ⇒ Vehicle diagnostic tester.

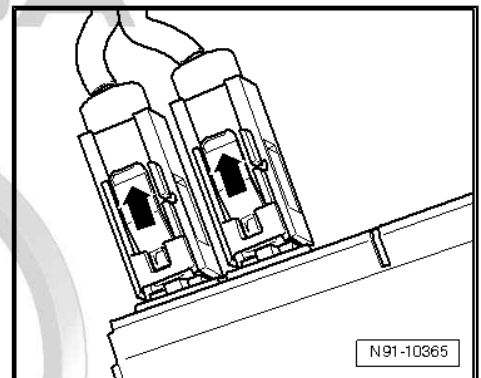

3.7 Self-diagnosis of the navigation system

Carry out "self-diagnosis" with the ⇒ Vehicle diagnostic tester in the function "Targeted fault finding".

Copying for private or commercial purposes, in part or in whole, is not permitted without the written consent of ŠKODA AUTO A. S. ŠKODA AUTO A. S. does not guarantee or accept any liability with respect to the correctness of information in this document. Copyright by ŠKODA AUTO A. S.

4 Telephone system

⇒ [“4.1 General Instructions”, page 54](#)

⇒ [“4.2 Basic mobile phone pre-installation”, page 55](#)

⇒ [“4.3 Universal mobile phone pre-installation with voice control GSM II”, page 55](#)

⇒ [“4.4 Universal mobile phone pre-installation with voice control GSM III”, page 56](#)

⇒ [“4.5 Summary of components, removing and installing the mount for the mobile phone”, page 56](#)

⇒ [“4.6 Removing and installing the control unit for the mobile phone operating electronics J412 \(vehicles up to CW 44/08\)”, page 58](#)

⇒ [“4.7 Removing and installing the control unit for the mobile phone operating electronics J412 \(vehicles as of CW 45/08\)”, page 59](#)

⇒ [“4.8 Removing and installing the microphone for the telephone R38”, page 60](#)

4.1 General Instructions

The mobile phone pre-installation is supplied in several versions:

- ◆ Basic mobile phone pre-installation
- ◆ Universal mobile phone pre-installation with voice control GSM II
- ◆ Universal mobile phone pre-installation with voice control GSM III as of CW 45/08

On vehicles fitted with mobile phone pre-installation there is the possibility later to retrofit mobile phones (portables).

The mobile phone pre-installation is only delivered together with the radio/navigation.

Copyright © SKODA AUTO A. S. SKODA AUTO A. S. does not guarantee or accept any liability with respect to the correctness of information in this document. Copyright by SKODA AUTO A. S.



Note

As of CW 22.11, a Bluetooth module is integrated in the navigation system Amundsen+ which fulfills the function of the GSM II mobile phone pre-installation. The control unit for the mobile phone operating electronics - J412- which is located under the right front seat, is no longer fitted (not valid for GSM III).

Further information and description of function:

- ◆ ⇒ Owner's manual Octavia II
- ◆ ⇒ Self-study programme No. 54 ; Second generation Škoda Octavia electrical components
- ◆ ⇒ Self-study programme No. 66 ; Škoda Superb II vehicle introduction part II. II
- ◆ ⇒ Self-study programme No. 81 ; Bluetooth in Škoda vehicles

4.2 Basic mobile phone pre-installation

- 1 - Roof aerial for radio/navigation and telephone
- 2 - Radio/navigation
- 3 - Door speakers
- 4 - Voltage supply (terminals 15, 31 and 58d)
- 5 - Plug for the mobile phone pre-installation, behind the radio
- 6 - Aerial line for the telephone, behind the radio

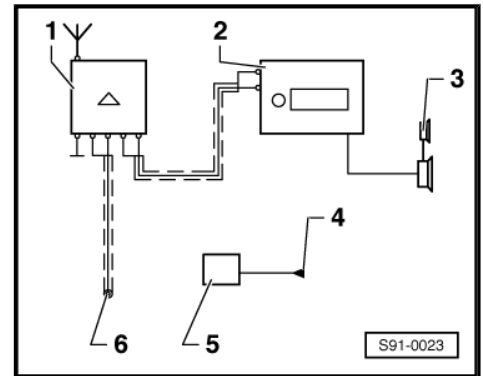

4.3 Universal mobile phone pre-installation with voice control GSM II



Note

As of CW 22.11, a Bluetooth module is integrated in the navigation system Amundsen+ which fulfills the function of the GSM II mobile phone pre-installation. The control unit for the mobile phone operating electronics - J412- pos. -10- below the right front seat is not required. The wiring loom of the microphone Pos. -4-, Gateway control unit Pos. -2- and of the mobile phone holder (if present) Pos. -11- leads directly into the navigation system, see ⇒ Current flow diagrams, Electrical fault finding and Fitting locations.

- 1 - Multi-function steering wheel - optional
- 2 - Data bus diagnostic interface Gateway - J533-
- 3 - Control unit in dash panel insert - J285-
- 4 - Microphone for the telephone - R38- - in the front interior light
- 5 - Roof aerial for radio/navigation and telephone
- 6 - Radio/navigation
- 7 - Loudspeaker arrangement - right side
- 8 - Loudspeaker arrangement - left side
- 9 - Voltage supply of the control unit for the mobile phone operating electronics - J412-
- 10 - Control unit for the mobile phone operating electronics - J412-
- 11 - Phone holder with adapter - optional - for recharging and for amplifying the aerial signal
- 12 - Mobile phone - data transmission between the telephone and the control unit via the wireless BT communication or via the mobile phone holder.
- 13 - Steering column electronics control unit - J527-

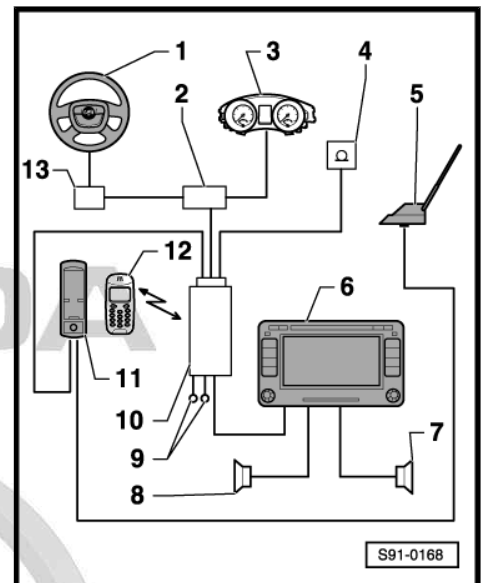

Protected by copyright. Copying for private or commercial purposes, in part or in whole, is not permitted unless authorised by SKODA AUTO A. S. SKODA AUTO A. S. does not guarantee or accept any liability with respect to the correctness of information in this document. Copyright by SKODA AUTO A. S.

4.4 Universal mobile phone pre-installation with voice control GSM III

- 1 - Control unit in dash panel insert - J285-
- 2 - Multi-functional steering wheel
- 3 - Steering column electronics control unit - J527-
- 4 - Roof aerial
- 5 - Data bus diagnostic interface Gateway - J533-
- 6 - Voltage supply of the control unit for the mobile phone operating electronics - J412-
- 7 - Control unit for the mobile phone operating electronics - J412-
- 8 - Notebook, Laptop (is not a component part of the preinstallation)
- 9 - Headset unit - enables private phone calls in the vehicle (is not a component part of the preinstallation)
- 10 - Mobile phone
- 11 - Microphone for the telephone - R38- - in the front interior light
- 12 - Loudspeaker arrangement - left side
- 13 - Radio/navigation
- 14 - Loudspeaker arrangement - right side

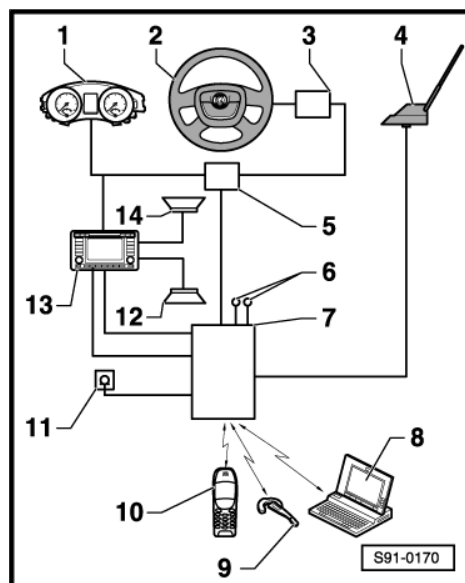

4.5 Summary of components, removing and installing the mount for the mobile phone

⇒ [“4.5.1 Assembly overview of mobile phone mount”, page 56](#)

⇒ [“4.5.2 Removing and installing the mount for the mobile phone”, page 57](#)

4.5.1 Assembly overview of mobile phone mount

ŠKODA



- 1 - Radio cover frame
- 2 - Mount for the mobile phone holder
- 3 - 1.5 Nm
- 4 - Mount for mobile phone
- 5 - Cap
- 6 - 1.5 Nm
- 7 - Attachment angle
- 8 - Radio

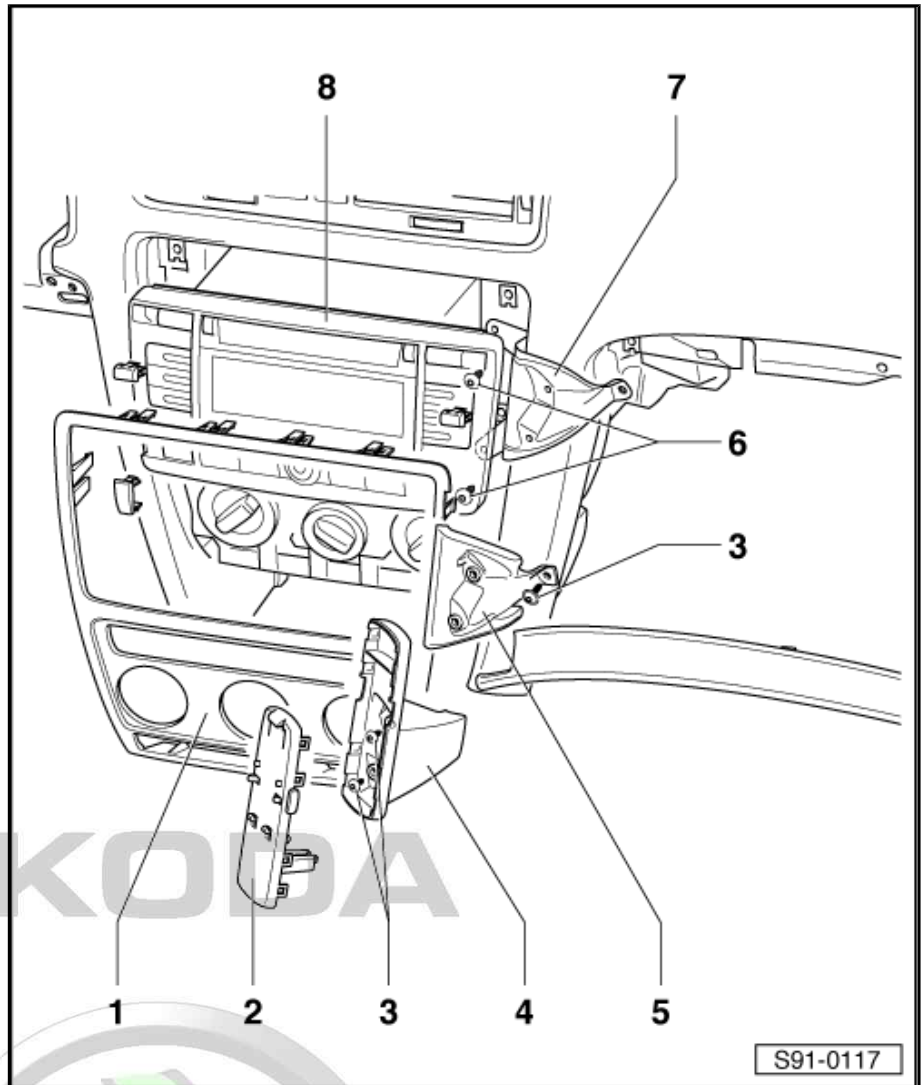

4.5.2 Removing and installing the mount for the mobile phone

Removing

- Switch off the ignition and all electrical consumers!
- Take the mobile phone out of the mount.



Caution

When using the lever tool, mask points where the lever tool is applied using commercially available adhesive tape.

Protected by copyright. Copying for private or commercial purposes, in part or in whole, is not permitted unless authorised by ŠKODA AUTO A. S. ŠKODA AUTO A. S. does not guarantee or accept any liability with respect to the correctness of information in this document. Copyright by ŠKODA AUTO A. S. ©



- Release with a small screwdriver the upper cover of the mobile phone console with mobile phone carrier from the catches -arrows-.
- Unscrew fixing screws -3- (1.5 Nm) of the mobile phone holder -1-.
- Remove glove compartment on front passenger side ⇒ Body Work; Rep. gr. 70 .
- Unhook the mobile phone holder -1- downwards and disconnect plug connections.

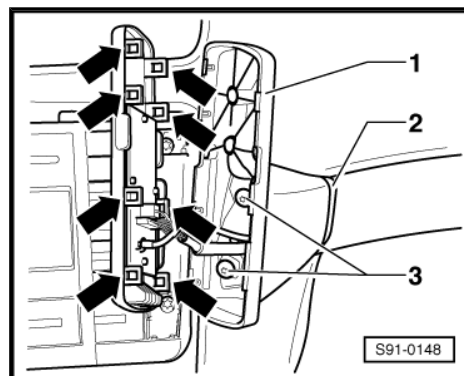

- Release screw -arrow- (1.5 Nm) and remove the cover -2- of the locking plate.
- When removing the locking plate -2- remove the radio -1- ⇒ [page 33](#) .

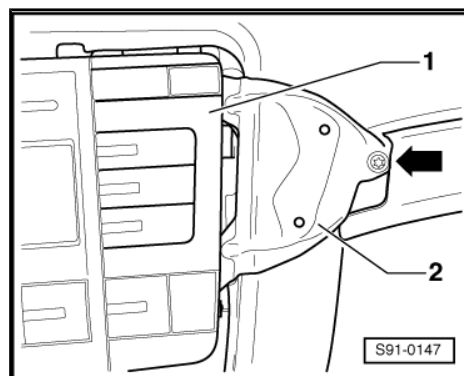

Installing

The installation occurs in reverse order.

4.6 Removing and installing the control unit for the mobile phone operating electronics - J412- (vehicles up to CW 44/08)



Note

The control unit for the mobile phone operating electronics - J412- cannot be exchanged with the control units mounted as of CW 45.08 (new dash panel insert) see ⇒ Electronic Catalogue of Original Parts .

Removing

Left-hand drive vehicles:

- Remove front passenger seat ⇒ Body Work; Rep. gr. 72 .

Right-hand drive vehicles:

- Remove the driver's seat ⇒ Body Work; Rep. gr. 72 .

Protected by copyright. Copying for private or commercial purposes, in part or in whole, is not permitted unless authorised by ŠKODA AUTO A. S. ŠKODA AUTO A. S. does not guarantee or accept any liability with respect to the correctness of information in this document. Copyright by ŠKODA AUTO A. S. ©

Continued for all vehicles:

- Unclip clips -arrows-.
- Remove cover of control unit -1-.
- Disconnect plug connection -2-.
- Release screws -A- (1.7 Nm).
- Disconnect aerial for bluetooth -3- (if present).
- Remove the control unit holder from the vehicle.
- Remove the control unit from the holder in -direction of arrow-.

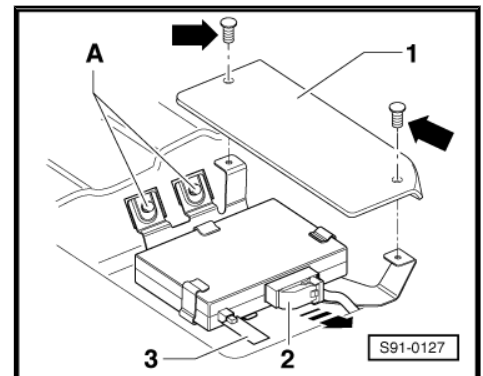

Installing

Installation is carried out in the reverse order. When installing, observe the following:

- When replacing, code the new control unit after the installation
=> Vehicle diagnostic tester

4.7 Removing and installing the control unit for the mobile phone operating electronics - J412- (vehicles as of CW 45/08)

i Note

- ◆ *The control unit for the mobile phone operating electronics - J412- cannot be exchanged with the control units mounted up to CW 44.08 (old dash panel insert) see -> Electronic Catalogue of Original Parts .*
- ◆ *As of CW 22.11, a Bluetooth module is integrated in the navigation system Amundsen which fulfills the function of the GSM II mobile phone pre-installation. On vehicles equipped with this navigation system and with the GSM II mobile phone pre-installation, the control unit for the mobile phone operating electronics - J412- is no longer installed separately as of CW 22.11.*

The control unit for the mobile phone operating electronics - J412- is located below the right front seat.

Removing

- Switch off all electrical components and take out the ignition key.
- Push the right front seat completely towards the rear and the highest point.
- Slightly raise the edges of the cover -arrows A- and pull out the cover -arrow B-.

GSM II - vehicles up to CW 21/10

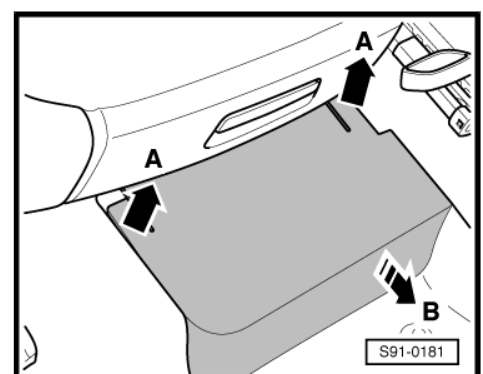

- Release screw -4- (6 Nm).
- Slightly raise the bracket for the control unit -5- -arrow A- and pull out the control unit -3- -arrow B-.
- Unlock by tilting out the clamp -2- and disconnect the plug connection -1-.

GSM II - vehicles as of CW 22/10 and GSM III

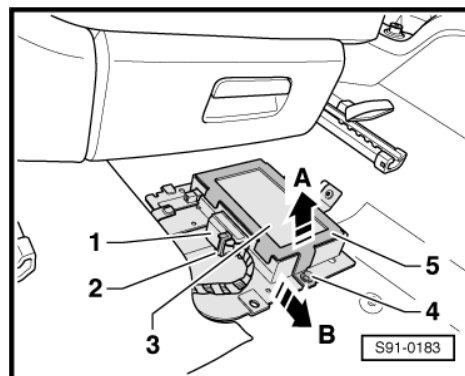

- Release screws -arrows- (3 Nm).

ŠKODA

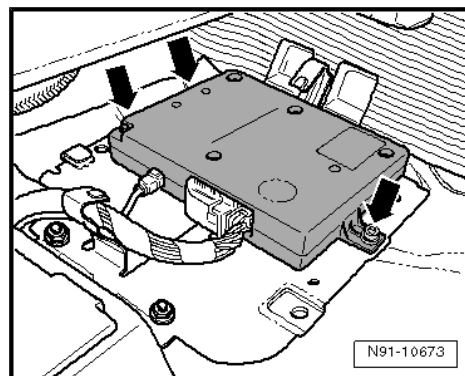

- Press the catch -A- and disconnect the plug connection by tilting out the clamp -arrow B-.
- Unlock the plug of the aerial cable (where available) -arrows- and detach.

Installing

Installation is carried out in the reverse order. When installing, observe the following:

- When replacing, code the new control unit after the installation ⇒ Vehicle diagnostic tester.

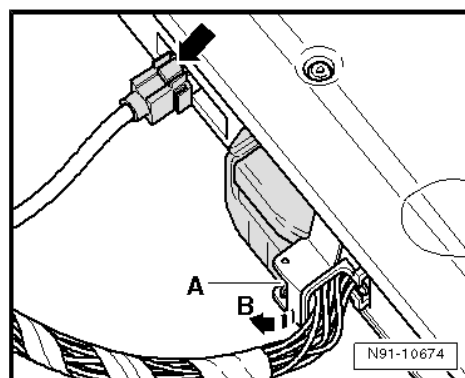

4.8 Removing and installing the microphone for the telephone - R38-

The microphone is located in the interior light.

Removing

- Remove interior light ⇒ [page 161](#) .
- Disconnect the plug connection -1- and take the microphone -2- out of the interior light.

Installing

The installation occurs in reverse order.

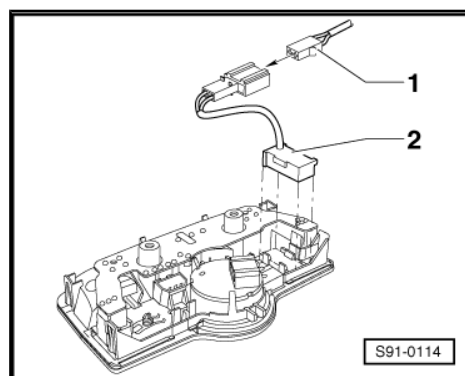

5 Multi-functional steering wheel



Note

When handling a fault, it is absolutely essential to know the function and operation of the multi-functional steering wheel. Additional information and description of function ⇒ Owner's manual Octavia II .

⇒ [“5.1 Multifunctional steering wheel- vehicles up to MY 08”, page 61](#)

⇒ [“5.2 Multifunctional steering wheel- vehicles as of MY 09”, page 63](#)

⇒ [“5.3 Self-diagnosis of the multi-functional steering wheel”, page 65](#)

5.1 Multifunctional steering wheel- vehicles up to MY 08

⇒ [“5.1.1 General description”, page 61](#)

⇒ [“5.1.2 Summary of components”, page 61](#)

⇒ [“5.1.3 Removing and installing the multifunction buttons in the steering wheel”, page 62](#)

⇒ [“5.1.4 Removing and installing the control unit for the multi-functional steering wheel”, page 63](#)

5.1.1 General description

The multi-functional steering wheel control unit - J453- communicates with the steering column electronics control unit - J527- . Here the data commands are once again controlled for further communication.

The multi-functional steering wheel is available in two versions:

◆ Audio

◆ Audio + Telephone

Protected by copyright. Reproduction for private or commercial purposes, in part or in whole, is not permitted unless authorized by SKODA AUTO A. S. SKODA AUTO A. S. does not guarantee or accept any liability with respect to the correctness of information in this document. Copyright by SKODA AUTO A. S.®

5.1.2 Summary of components



- 1 - Steering wheel
- 2 - Right switch unit - E441-
 - ❑ identical for both versions of the multi-functional steering wheel
 - ❑ Removing ⇒ [page 62](#)
- 3 - Multi-functional steering wheel control unit - J453-
 - ❑ Removing ⇒ [page 63](#)
- 4 - Wiring loom
- 5 - Airbag unit
 - ❑ removing ⇒ Body work; Rep. gr. 69
- 6 - Left switch unit - E440-
 - ❑ Removing ⇒ [page 62](#)

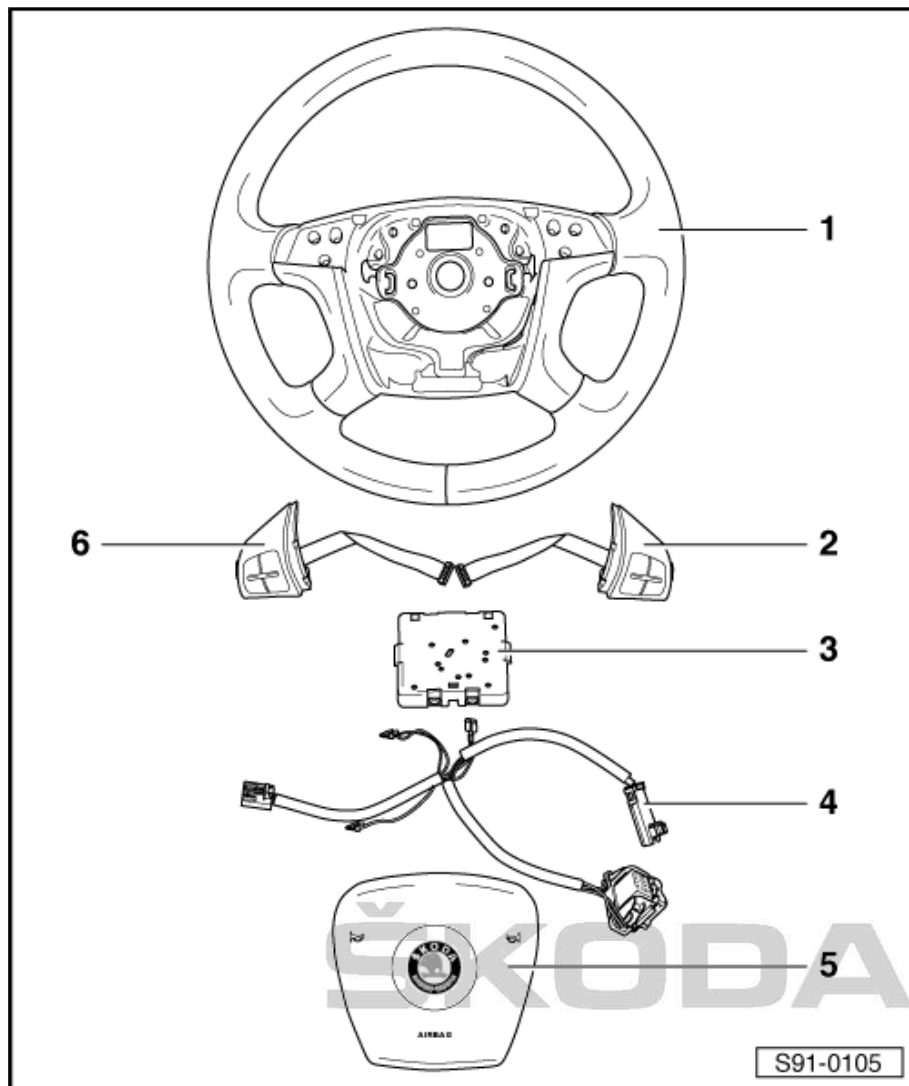

5.1.3 Removing and installing the multifunction buttons in the steering wheel

The mounting sequence is identical for both switch units.

Removing

- Remove knee airbag driver's side ⇒ Body Work; Rep. gr. 69 .
- Disconnect plug -1- from the multi-function steering wheel control unit.
- Remove the multifunction buttons in -direction of arrow A-.

Installing

The installation occurs in reverse order.

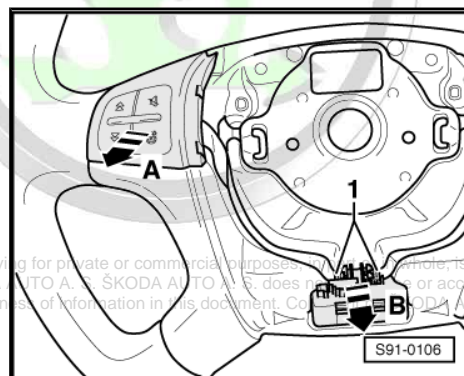

Protected by copyright. Copying for private or commercial purposes without the prior written permission of ŠKODA AUTO A. S. ŠKODA AUTO A. S. does not accept any liability with respect to the correctness of information in this document. Copyright © ŠKODA AUTO A. S. 2013

5.1.4 Removing and installing the control unit for the multi-functional steering wheel

Removing

- Remove knee airbag driver's side ⇒ Body Work; Rep. gr. 69 .
- Disconnect plug -1- from the multi-function steering wheel control unit.
- Remove the control unit in the -direction of the arrow B-



Note

A new control unit must be coded if the control unit for the multi-functional steering wheel is replaced ⇒ Vehicle diagnostic tester.

Installing

Installation is carried out in the reverse order. When installing, observe the following:



Note

- ◆ Before the airbag is installed, it must be checked if all the wiring is properly pressed back into the guiding grooves in the steering wheel foam. Wiring which protrudes can be damaged by the backside parts of the airbag.
- ◆ Follow the work procedure when connecting the battery ⇒ [page 2](#) .

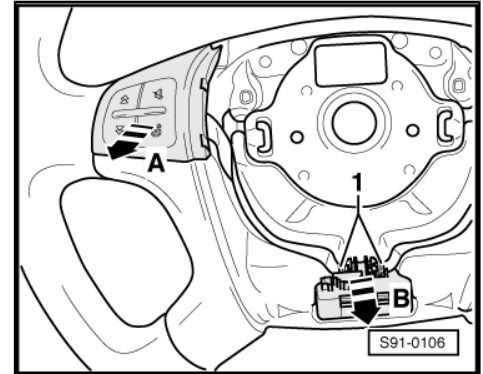

5.2 Multifunctional steering wheel- vehicles as of MY 09

⇒ [“5.2.1 General description”, page 63](#)

⇒ [“5.2.2 Removing and installing switch units for operating the audio and phone”, page 64](#)

⇒ [“5.2.3 Removing and installing switch units for gearbox operation in Tiptronic mode \(gearbox 02E, 0AM – DSG\)”, page 64](#)

5.2.1 General description

The multi-functional steering wheel contains (depending upon equipment) the following components:

- ◆ Multifunction buttons in the steering wheel on the left - E440- and right -E441- for the operation of the audio and telephone
- ◆ Tiptronic switch in the steering wheel up - E438- and down - E439- for the operation of the double clutch gearbox in Tiptronic mode (gearbox 02E and 0AM).
- ◆ Wiring loom
- ◆ Multifunctional steering wheel control unit - J453- , integrated in the left front switch unit

The multi-functional steering wheel control unit communicates with the steering column electronics control unit. Here the data commands are once again controlled for further communication.

Versions of the multi-functional steering wheel:

1 - Four-spoke steering wheel

- for audio
- for audio und telephone
- 2 - Three-spoke steering wheel
- for audio
- for audio und telephone
- 3 - Three-spoke steering wheel
- for audio, telephone and gearbox operation in the Tiptronic mode (gearbox 02E - DSG)

5.2.2 Removing and installing switch units for operating the audio and phone

The mounting sequence is identical for both switch units.

Removing

- Remove the airbag unit in the steering wheel ⇒ Body Work; Rep. gr. 69 .
- Clear away wiring harness -arrows- and disconnect plug connection -1- from the switch unit.

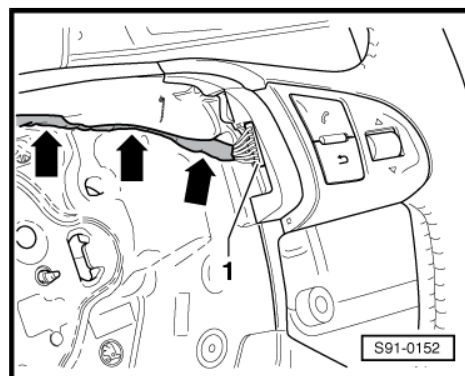

- Swivel out the switch unit -2- -arrow- until the locking bolts -1- become loose, push it slightly and pull it out.

Installing

Installation is carried out in the reverse order. When installing, observe the following:



Note

- ◆ *Before the airbag is installed, it must be checked if all the wiring is properly pressed back into the guiding grooves in the steering wheel foam. Wiring which protrudes can be damaged by the backside parts of the airbag.*
- ◆ *Follow the work procedure when connecting the battery ⇒ [page 2](#) .*
- If the left switch unit has been replaced by an integrated control unit, coding must be performed with ⇒ Vehicle diagnostic tester.

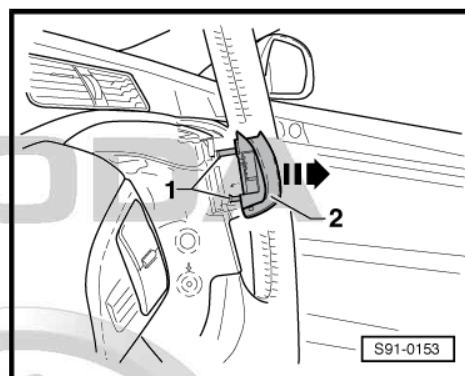

5.2.3 Removing and installing switch units for gearbox operation in Tiptronic mode (gearbox 02E, 0AM – DSG)

The mounting sequence is identical for both switch units.

Removing

- Remove the airbag unit in the steering wheel ⇒ Body Work; Rep. gr. 69 .
- Disconnect plug connection -2-.
- Screw out screw -1- (1.5 Nm), swivel out the switch unit for the gearbox operation -3- -arrow- and carefully remove.

Installing

The installation occurs in reverse order.

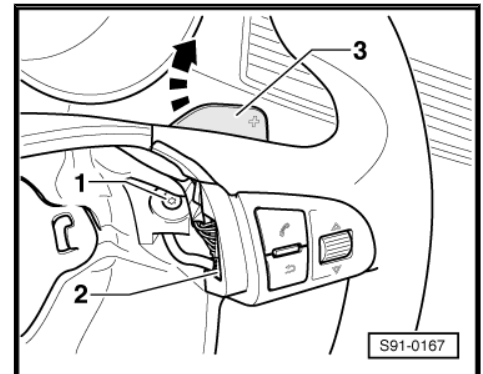

5.3 Self-diagnosis of the multi-functional steering wheel

The multi-functional steering wheel is capable of conducting a self-diagnosis. Carry out "self-diagnosis" with the ⇒ Vehicle diagnostic tester in the function "Targeted fault finding".

part or in whole, is not permitted unless authorised by ŠKODA AUTO A. S. ŠKODA AUTO A. S. does not guarantee or accept any liability with respect to the correctness of information in this document. Copyright by ŠKODA AUTO A. S. ©



6 Sound system

⇒ [“6.1 General Instructions”, page 66](#)

⇒ [“6.2 General description”, page 66](#)

⇒ [“6.3 Overall view of the equipment Soundsystem”, page 66](#)

⇒ [“6.4 Removing and installing amplifier R12 \(up to MY 08\)”, page 68](#)

⇒ [“6.5 Removing and installing amplifier R12 \(vehicles as of MY 09\)”, page 68](#)

⇒ [“6.6 Contact assignment at the amplifier - vehicles up to MY 08”, page 70](#)

⇒ [“6.7 Contact assignment at the amplifier - vehicles as of MY 09”, page 72](#)

⇒ [“6.8 Self-diagnosis of the equipment Soundsystem”, page 73](#)

6.1 General Instructions



Note

- ◆ *When retrofitting equipment, carrying out repair work or fault finding ⇒ Current flow diagrams, Electrical fault finding and Fitting locations and ⇒ Installation instructions for radio .*
- ◆ *Detailed assembly information, e.g. detaching and attaching trim panels ⇒ Body Work; Rep. gr. 70 .*

Protected by copyright. Copying for private or commercial purposes, in part or in whole, is not permitted without the prior written consent of ŠKODA AUTO A. S. or its subsidiaries. ŠKODA AUTO A. S. does not guarantee or accept any liability for the content of this document. Copyright by ŠKODA AUTO A. S. 2013

6.2 General description

The basis of the system is an external eight channel and, as of MY 09, a ten channel audio amplifier with digital signal processing - R12-. The interface between amplifier and radio is formed by 4 low frequency lines and the CAN bus infotainment. The self-diagnosis of the amplifier and the loudspeakers is carried out via the CAN bus infotainment, which is also used by the amplifier of the equipment Soundsystem for the communication with the radio/navigation system. By means of the messages sent by radio/navigation system to the databus, the switching on/off of the amplifier, the switch-over between the six effects specified by the manufacturer is performed in the DSP (Digital Sound Processor). Therefore the equipment Soundsystem can only be combined with the radio Audience (up to MY 08), Bolero (as of MY 09) and with the navigation systems Amundsen and Columbus (as of MY 09), which contain an implemented menu for changing the DSP effects and enable the switching on and off of the amplifier.

6.3 Overall view of the equipment Soundsystem

1 - Radio/navigation

- installed in centre console
- Removing and installing ⇒ [page 30](#)
- Plug at radio ⇒ [page 30](#) or navigation system ⇒ [page 50](#)

2 - Roof aerial

- with aerial amplifier
- Removing and installing ⇒ [page 40](#)
- on vehicles as of CW 01/07 the aerial is also installed in the rear window, it is installed in the rear right window on Combi vehicles

3 - Rear treble speaker

- installed next to the rear door handle lever
- Removing and installing ⇒ [page 30](#)

4 - Rear window aerial

- Assembly as of CW 01/07 - for radio/navigation with two tuners (two antenna sockets)
- fitted in the rear right window on Octavia Combi
- further information in the chapter aerial systems ⇒ [page 40](#)

5 - Rear midrange speaker

- screwed onto the rear door trim panel
- Removing and installing ⇒ [page 76](#)

6 - Rear bass speaker

- installed in door
- Removing and installing ⇒ [page 30](#)

7 - Front midrange speaker

- screwed onto the front door trim panel
- Removing and installing ⇒ [page 75](#)

8 - Front bass speaker

- installed in door
- Removing and installing ⇒ [page 30](#)

9 - Front treble speaker

- installed next to the front door opening lever
- Removing and installing ⇒ [page 30](#)

10 - Amplifier - R12-

Left-hand drive vehicles:

- installed under the driver seat

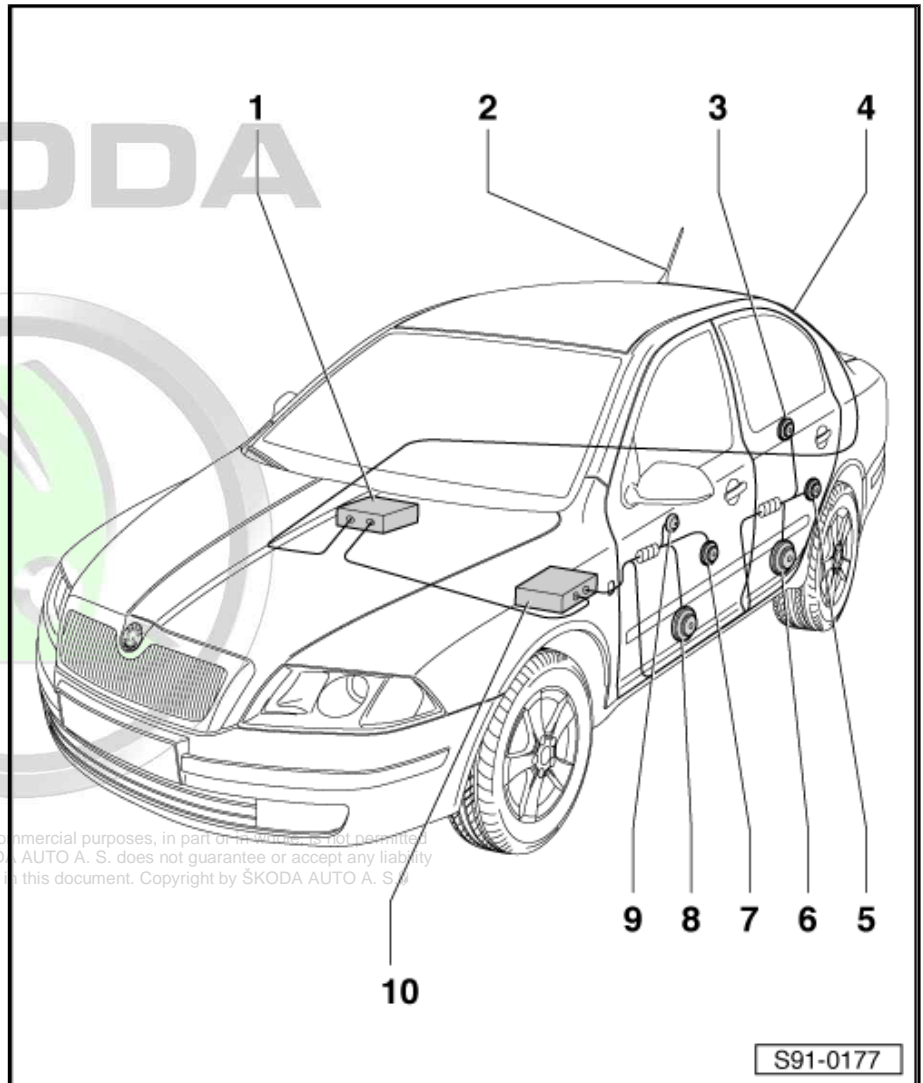

Right-hand drive vehicles:

- installed under the front passenger seat
- installing and removing - vehicles up to MY 08 - [⇒ page 68](#)
- installing and removing - vehicles as of MY 09 [⇒ page 68](#)

6.4 Removing and installing amplifier - R12- (up to MY 08)

Removing

- Switch off all electrical components and take out the ignition key.

Left-hand drive vehicles:

- Remove the driver's seat ⇒ Body Work; Rep. gr. 72 .

Right-hand drive vehicles:

- Remove front passenger seat ⇒ Body Work; Rep. gr. 72 .

Continued for all vehicles:

- Unclip clips -2-.
- Remove cover from amplifier.
- Disconnect connector -1-.
- Release nuts -arrows- (5,5 Nm).
- Remove amplifier.

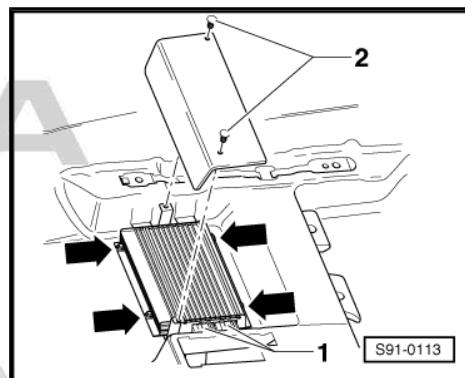

Installing

Installation is carried out in the reverse order. When installing, observe the following:

- When replacing, code the new control unit with the ⇒ Vehicle diagnostic tester.

6.5 Removing and installing amplifier - R12- (vehicles as of MY 09)

Removing

- Switch off all electrical components and take out the ignition key.
- Push the left front seat completely towards the rear and the highest point.
- Slightly raise the edges of the cover -arrows A- and pull out the cover -arrow B-.

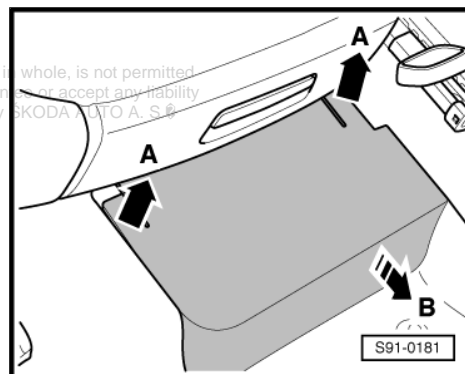

Protected by copyright. Copying for private or commercial purposes, in part or in whole, is not permitted unless authorised by ŠKODA AUTO A. S. ŠKODA AUTO A. S. does not guarantee or accept any liability with respect to the correctness of information in this document. Copyright by ŠKODA AUTO A. S. ©

- Release screws (6 Nm) and pull out the amplifier from the bracket.
- Slacken by tilting out the clamp and disconnect the plug connection.

Installing

Installation is carried out in the reverse order. When installing, observe the following:

- When replacing, code the new control unit with the ⇒ Vehicle diagnostic tester.

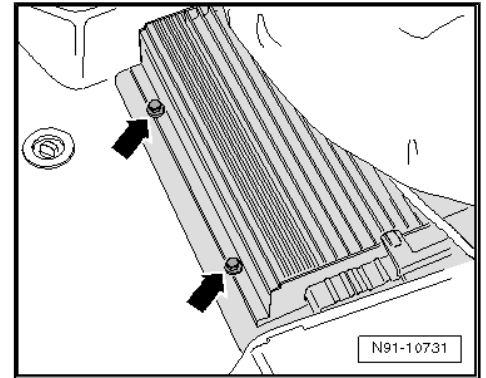

ŠKODA



Protected by copyright. Copying for private or commercial purposes, in part or in whole, is not permitted unless authorised by ŠKODA AUTO A. S. ŠKODA AUTO A. S. does not guarantee or accept any liability with respect to the correctness of information in this document. Copyright by ŠKODA AUTO A. S. ©

6.6 Contact assignment at the amplifier - vehicles up to MY 08

Multi-pin plug connection -A-, 23-pin

- 1 - Treble speaker and midrange speaker rear left +
- 2 - Treble speaker and midrange speaker rear left -
- 3 - Bass speaker rear left +
- 4 - Bass speaker rear right +
- 5 - Bass speaker rear right -
- 6 - Bass speaker rear left -
- 7 - Treble speaker and midrange speaker rear right +
- 8 - Treble speaker and midrange speaker rear right -
- 9 - not assigned
- 10 - Midrange speaker front left +
- 11 - Midrange speaker front left -
- 12 - Bass speaker front left +
- 13 - Bass speaker front right +
- 14 - Bass speaker front right -
- 15 - Bass speaker front left -
- 16 - Midrange speaker front right +
- 17 - Midrange speaker front right -
- 18 - Terminal 30; + 12 V
- 19 - Terminal 31; earth
- 20 - Terminal 31; earth
- 21 - Terminal 30; + 12 V
- 22 - Terminal 31; earth
- 23 - Terminal 30; + 12 V

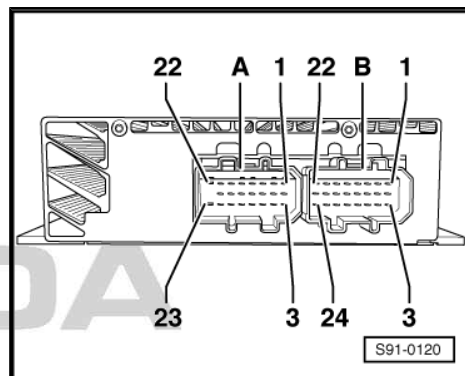

Protected by copyright. Copying for private or commercial purposes, in part or in whole, is not permitted unless authorised by ŠKODA AUTO A. S. ŠKODA AUTO A. S. does not guarantee or accept any liability with respect to the correctness of information in this document. Copyright by ŠKODA AUTO A. S. ©

Multipin plug connection -B-, 24-pin

- 1 - CAN bus High
- 2 - not assigned
- 3 - CAN bus Low
- 4 - not assigned
- 5 - not assigned
- 6 - not assigned
- 7 - not assigned
- 8 - not assigned
- 9 - not assigned
- 10 - not assigned
- 11 - Radio NF signal front left +
- 12 - Radio NF signal front left -
- 13 - not assigned
- 14 - Radio NF signal front right +



- 15 - Radio NF signal front right -
- 16 - not assigned
- 17 - Radio NF signal rear left +
- 18 - Radio NF signal rear left -
- 19 - not assigned
- 20 - Radio NF signal rear right +
- 21 - Radio NF signal rear right -
- 22 - not assigned
- 23 - not assigned
- 24 - not assigned

ŠKODA



Protected by copyright. Copying for private or commercial purposes, in part or in whole, is not permitted unless authorised by ŠKODA AUTO A. S. ŠKODA AUTO A. S. does not guarantee or accept any liability with respect to the correctness of information in this document. Copyright by ŠKODA AUTO A. S. ©



6.7 Contact assignment at the amplifier - vehicles as of MY 09

Contact assignment of the 38-pin plug connection

- 1 - Terminal 31
- 2 - Terminal 30
- 3 - Midrange speaker front right -
- 4 - Bass speaker front right -
- 5 - Bass speaker front left +
- 6 - Midrange speaker front left -
- 7 - Treble speaker front right -
- 8 - Treble speaker front left +
- 9 - Bass speaker rear left +
- 10 - Bass speaker rear right -
- 11 - Treble speaker and midrange speaker rear right -
- 12 - Treble speaker and midrange speaker rear right +
- 13 - Treble speaker and midrange speaker rear left +
- 14 - Treble speaker and midrange speaker rear left -
- 15 - Midrange speaker front right +
- 16 - Bass speaker front right +
- 17 - Bass speaker front left -
- 18 - Midrange speaker front left +
- 19 - Treble speaker front right +
- 20 - Treble speaker front left +
- 21 - Bass speaker rear left -
- 22 - Bass speaker rear right +
- 23 - CAN bus Low
- 24 - not assigned
- 25 - not assigned
- 26 - not assigned
- 27 - Mono 1 left, input -
- 28 - Mono 2 right, input -
- 29 - Left stereo, input -
- 30 - Right stereo, input -
- 31 - CAN bus High
- 32 - not assigned
- 33 - not assigned
- 34 - not assigned
- 35 - Mono 1 left, input +
- 36 - Mono 2 left, input +
- 37 - Left stereo, input +

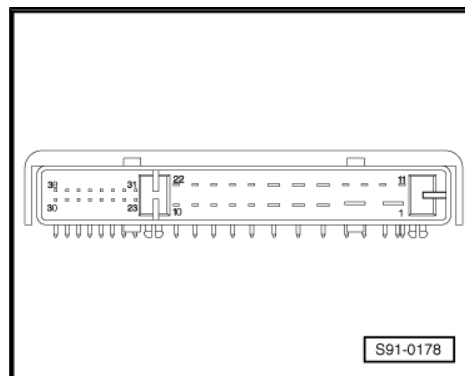



38 - Right stereo, input +

6.8 Self-diagnosis of the equipment Sound-system

Carry out "self-diagnosis" with the ⇒ Vehicle diagnostic tester in the function "Targeted fault finding".

ŠKODA



Protected by copyright. Copying for private or commercial purposes, in part or in whole, is not permitted unless authorised by ŠKODA AUTO A. S. ŠKODA AUTO A. S. does not guarantee or accept any liability with respect to the correctness of information in this document. Copyright by ŠKODA AUTO A. S. ©

7 Loudspeaker system

⇒ [“7.1 Removing and installing loudspeakers”, page 74](#)

7.1 Removing and installing loudspeakers

⇒ [“7.1.1 Removing and installing the front bass loudspeaker”, page 74](#)

⇒ [“7.1.2 Removing and installing the rear bass loudspeaker”, page 74](#)

⇒ [“7.1.3 Removing and installing the front treble speaker”, page 75](#)

⇒ [“7.1.4 Removing and installing the rear treble speaker”, page 75](#)

⇒ [“7.1.5 Removing and installing the front midrange speaker”, page 75](#)

⇒ [“7.1.6 Removing and installing the rear midrange speaker”, page 76](#)

7.1.1 Removing and installing the front bass loudspeaker

Removing

- Switch off radio/navigation.
- Remove the front door panelings ⇒ Body Work; Rep. gr. 70 .
- Disconnect socket connector at the loudspeaker.
- Use a suitable drill to drill open the six rivets -arrows- and take out the faulty speaker.



Note

- ◆ *It is important to remove all the drill swarf from the door since it can otherwise lead to corrosion.*
- ◆ *Any damage to the paintwork which is caused by drilling out the rivets must be repaired immediately by a specialist.*

Installing

- Attach the new speaker with matching blind rivets.
- Further installation occurs in reverse order.

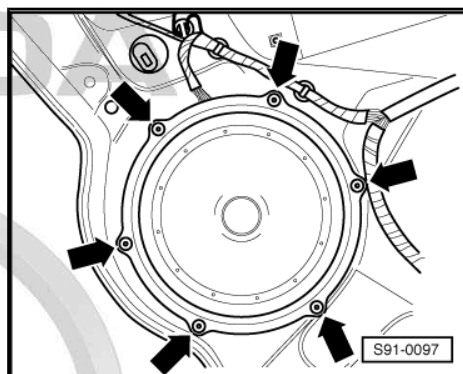

7.1.2 Removing and installing the rear bass loudspeaker

Removing

- Switch off radio/navigation.
- Remove the rear door panelings ⇒ Body Work; Rep. gr. 70 .
- Disconnect socket connector at the loudspeaker.

Protected by copyright. Copying for private or commercial purposes, in part or in whole, is not permitted. ŠKODA AUTO A. S. does not guarantee or accept any liability with respect to the correctness of information in this document. Copyright by ŠKODA AUTO A. S.

- Use a suitable drill to drill open the four rivets -arrows- and take out the faulty speaker.

 **Note**

- ◆ *It is important to remove all the drill swarf from the door since it can otherwise lead to corrosion.*
- ◆ *Any damage to the paintwork which is caused by drilling out the rivets must be repaired immediately by a specialist.*

Installing

- Attach the new speaker with matching blind rivets.
- Further installation occurs in reverse order.

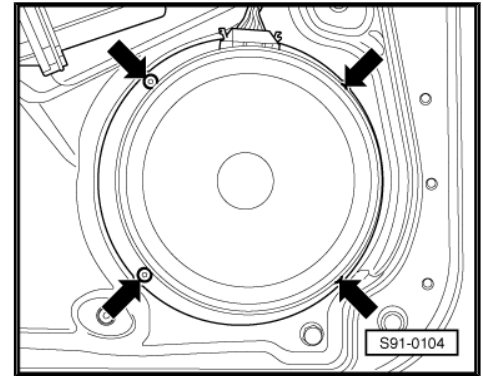

7.1.3 Removing and installing the front treble speaker

The front treble speakers in the front doors are firmly connected with the inner door control.

Removing

- Switch off radio/navigation.
- Remove the front door panelings ⇒ Body Work; Rep. gr. 70 .
- Disconnect socket connector to the loudspeaker.
- Removing the inner door control ⇒ Body Work; Rep. gr. 57 .

Installing

The installation occurs in reverse order.

7.1.4 Removing and installing the rear treble speaker

The front treble speakers in the rear doors are firmly connected with the inner door control.

Removing

- Switch off radio/navigation.
- Remove the rear door panelings ⇒ Body Work; Rep. gr. 70 .
- Disconnect socket connector to the loudspeaker.
- Removing the inner door control ⇒ Body Work; Rep. gr. 58 .

Installing

The installation occurs in reverse order.

7.1.5 Removing and installing the front mid-range speaker

Only on vehicles with the equipment “Soundsystem”

Removing

- Switch off radio/navigation.
- Remove the front door panelings ⇒ Body Work; Rep. gr. 70 .
- Disconnect socket connector at the loudspeaker.

- Release screws -arrows- (1.1 Nm) and remove the defective loudspeaker.

Installing

The installation occurs in reverse order.

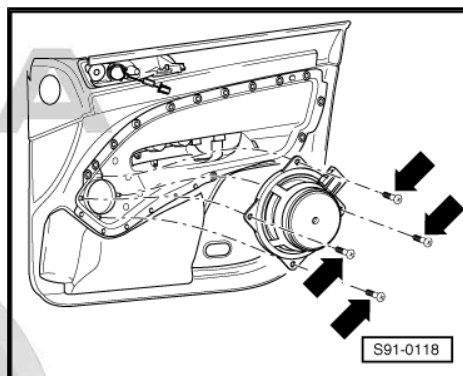

7.1.6 Removing and installing the rear mid-range speaker

Only on vehicles with the equipment "Soundsystem"

Removing

- Switch off radio/navigation.
- Remove the rear door panellings => Body Work; Rep. gr. 70 .
- Disconnect socket connector at the loudspeaker.
- Release screws -arrows- (1.1 Nm) and remove the defective loudspeaker.

Installing

The installation occurs in reverse order.

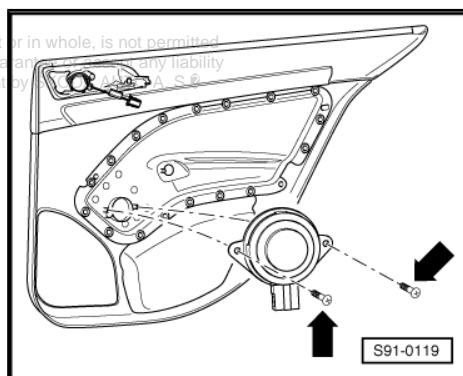

8 CD changer

The CD changer is located in the luggage compartment behind the removable left side trim panel.

Description of function ⇒ Owner's manual Octavia II .

Note

- ◆ *If the CD changer plays back commercially available CDs, however not burnt CDs, there is no fault in the CD changer. This is why it is not permitted to exchange the CD changer.*
- ◆ *No CD-Extra and Mix Mode CD (CD with computer and audio data together) can be played back.*
- ◆ *No audio CDs with a diameter of 8 cm (Mini CD) can be played back.*
- ◆ *When upgrading the CD changer, the functions of the radio system/navigation system must be absolutely coded again ⇒ Vehicle diagnostic tester.*

⇒ [“8.1 Removing and installing CD changer”, page 77](#)

⇒ [“8.2 Contact assignment on the CD changer”, page 78](#)

8.1 Removing and installing CD changer

Special tools and workshop equipment required

- ◆ Release tool for radio - T 10057-

Removing

- Switch off radio/navigation, ignition and all electrical consumers.
- Insert unlocking tool for the radio into the openings as shown until it audibly clicks.
- Pull CD changer out of the bracket.

Note

- ◆ *Do not press aside or tilt the release tool for radio - T 10057-.*
- ◆ *In order to pull off the release tool for radio - T 10057- again, press in the side catches at the CD changer.*
- Disconnect plug.

Installing

The installation occurs in reverse order.

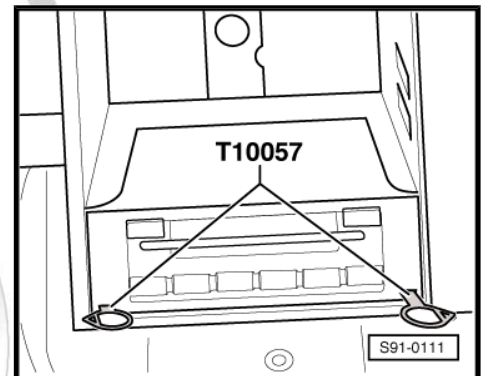



8.2 Contact assignment on the CD changer

Multipin plug connection, 12-pin

- 1 - Data CD out (in radio)
- 2 - CD-CLK out (in radio)
- 3 - CD earth
- 4 - Data CD in (out radio)
- 5 - not assigned
- 6 - 12 V power supply (from radio)
- 7 - right channel +
- 8 - switched positive (from radio)
- 9 - Signal ground
- 10 - left channel +
- 11 - not assigned
- 12 - not assigned

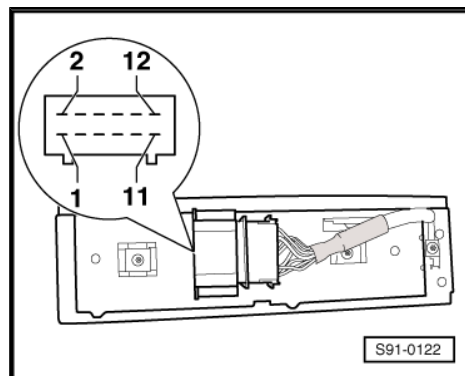

ŠKODA



Protected by copyright. Copying for private or commercial purposes, in part or in whole, is not permitted unless authorised by ŠKODA AUTO A. S. ŠKODA AUTO A. S. does not guarantee or accept any liability with respect to the correctness of information in this document. Copyright by ŠKODA AUTO A. S.®

9 Connection for external audio sources - R199- (AUX)

This is designed to connect the audio signal from the external stereo systems and to play back music from these systems via the radio/navigation installed ex works.

Contact assignment of plug connection and current flow diagram
⇒ Current flow diagrams, Electrical fault finding and Fitting locations.

Description of the function and additional information:

- ◆ ⇒ Owner's manual Octavia II
- ◆ ⇒ Operating instruction of the radio/navigation system

⇒ ["9.1 Removing and installing connection for external audio sources R199 \(AUX\)", page 79](#)

9.1 Removing and installing connection for external audio sources - R199- (AUX)

Removing

- Switch off the radio/navigation, all electrical consumers and take out the ignition key.
- Remove the centre console between driver and front passenger ⇒ Body Work; Rep. gr. 68 .
- Disconnect plug.
- Press together the retaining tabs -arrows- and push connection for external audio sources -1- out of the centre console -2-.

Installing

The installation occurs in reverse order.

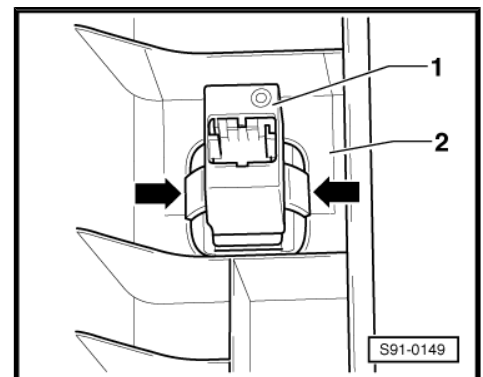

Protected by copyright. Copying for private or commercial purposes, in part or in whole, is not permitted unless authorised by ŠKODA AUTO A. S. ŠKODA AUTO A. S. does not guarantee or accept any liability with respect to the correctness of information in this document. Copyright by ŠKODA AUTO A. S. ©

10 Connection for external audio sources MEDIA-IN (multimedia socket)

The connector socket for external audio sources is located in the glove compartment on the front passenger side and is connected to the multimedia socket control unit.

Further information and description of function:

- ◆ ⇒ Owner's manual Octavia II
- ◆ ⇒ Operating instruction of the radio/navigation system
- ◆ ⇒ Self-study programme No. 72 ;

⇒ ["10.1 Removing and installing connector socket for external audio sources \(multimedia socket\)", page 80](#)

⇒ ["10.2 Removing and installing multimedia socket control unit", page 80](#)

10.1 Removing and installing connector socket for external audio sources (multimedia socket)

Removing

- Remove glove compartment on front passenger side ⇒ Body Work; Rep. gr. 70 .
- Disconnect plug -4- from the multi-function steering wheel control unit.

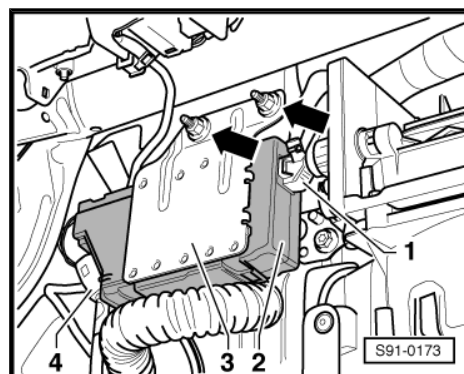

- Protected by copyright. Copying for private or commercial purposes, in part or in whole, is not permitted unless authorised by SKODA AUTO A. S. SKODA AUTO A. S. does not guarantee or accept any liability for errors or omissions.
- Press together the catch pegs -arrows A- and push out the cover of the socket -2- in the glove compartment.

- Press together the catch pegs from out of the glove compartment -arrow B- and take out the socket with the cable -1-.

Installing

The installation occurs in reverse order.

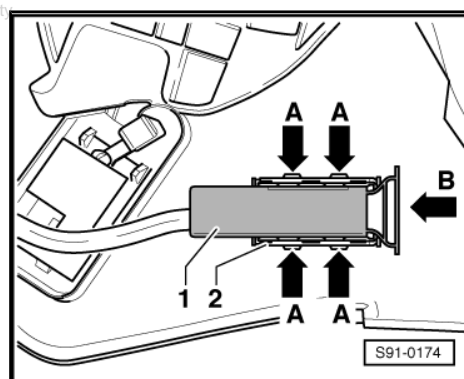

10.2 Removing and installing multimedia socket control unit

Removing

- Switch off the ignition and all electrical consumers!
- Remove glove compartment on front passenger side ⇒ Body Work; Rep. gr. 70 .

- Release the fixing nuts -arrows- for the bracket of the multimedia socket control unit and unhook the control unit -2- with bracket -3- downwards.
- Disconnect the plug connections.
- If necessary push the multimedia socket control unit out of the bracket.

Installing

Installation is carried out in the reverse order. When installing, observe the following:

- If the control unit was replaced, the new control unit must be coded with ⇒ Vehicle diagnostic tester.

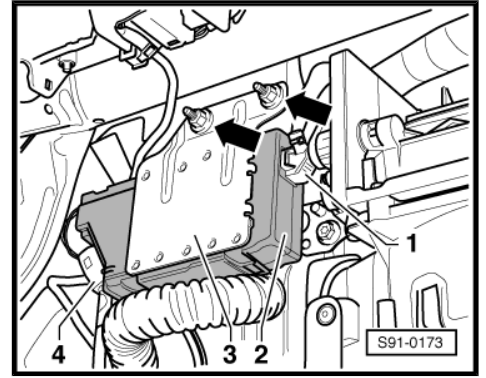

ŠKODA



92 – Windscreen wash/wipe system

1 Windscreen washer system

The function of the windscreen washer system can be checked with the ⇒ Vehicle diagnostic tester via the final control diagnosis of the vehicle voltage control unit - J519- .

⇒ [“1.1 Remove and install reservoir, pumps and sensor for washer fluid level”, page 82](#)

⇒ [“1.2 Removing and installing the spray nozzles for windscreen washer system”, page 83](#)

⇒ [“1.3 Removing and installing rear window spray nozzle Octavia”, page 84](#)

⇒ [“1.4 Removing and installing rear window spray nozzle Octavia Combi”, page 84](#)

⇒ [“1.5 Adjusting spray jet”, page 84](#)

⇒ [“1.6 Repairing washer fluid lines”, page 84](#)

1.1 Remove and install reservoir, pumps and sensor for washer fluid level

Removing



Note

- ◆ *Depending on the version, the positions of the individual components and the hose connection can differ slightly from the version in the illustrations. The removal occurs in the same way.*
- ◆ *For vehicles with auxiliary heating, there is a different arrangement of the pumps and the sensors at the reservoir, however their separation procedure is identical.*
- Switch off the ignition and all electrical consumers!
- Remove front bumper ⇒ Body Work; Rep. gr. 63 .
- Release the plugs from the washer fluid pumps for windscreen -2-, for headlight -10- and from the windscreen washer fluid level sender -6-.
- To unlock turn the locking clip on the hose connections -5- (black marking - front windscreen washer) and -3- (white marking - rear windscreen washer) and disconnect the connections from the washer fluid pump -4-. Collect the flowing out washer fluid in a suitable vessel.
- Release washer hose for headlight -8- by pressing the locking clip and detach.
- If necessary pull the washer fluid pumps -9- and -4- out of the reservoir to the top as well as the sensor for washer fluid level -7- out of the rubber bearing.
- Expose cable harness.

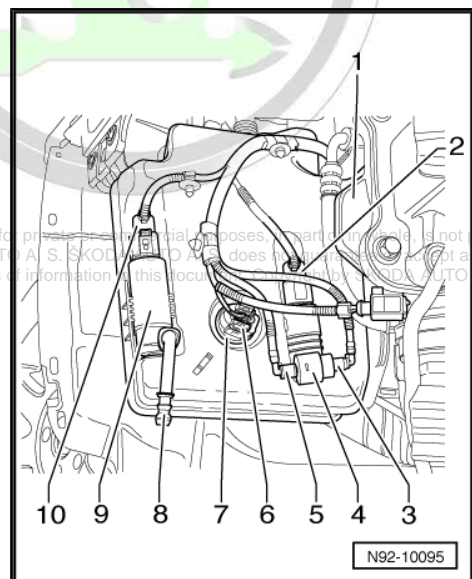

- Loosen pipe -3- for activated charcoal filter system or pipe for auxiliary heating from filler neck -2- of windshield washer reservoir.
- Remove cap from reservoir supports.
- Release screw -1- (8 Nm).

Vehicles without auxiliary heating

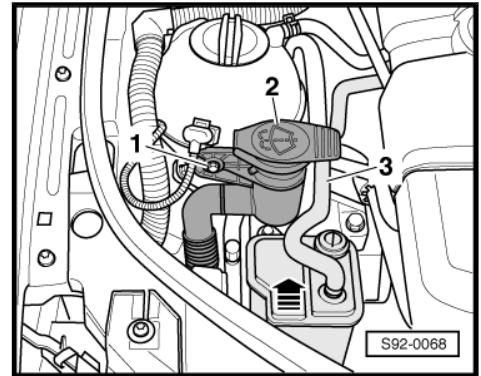

- Screw out screws and nuts -arrows- (8 Nm) and remove windshield washer fluid reservoir downwards.

Vehicles fitted with auxiliary heating

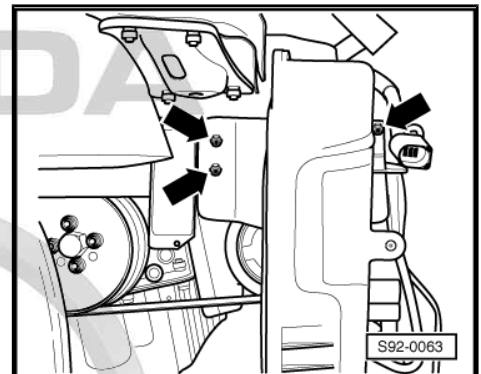

- Unscrew fixing screws -arrows- (8 Nm).
- Push the reservoir slightly forwards, during this procedure slacken it from the bearing in the bracket and remove it to the bottom.

Installing

Installation is carried out in the reverse order. When installing, observe the following:

- Hoses with angled pieces must click audibly into the connections on the washer fluid pumps.
- After completing the assembly work bleed the headlamp cleaning system ⇒ [page 96](#).

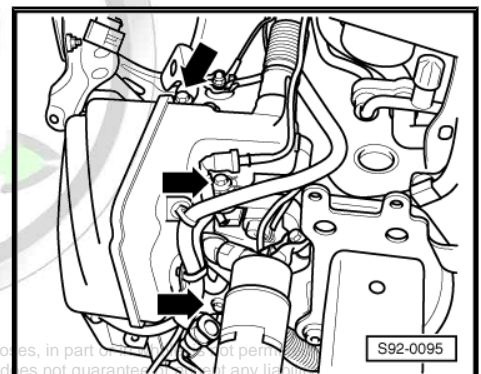

1.2 Removing and installing the spray nozzles for windscreen washer system

Removing

- Remove windscreen wiper arms ⇒ [page 85](#) .
- Remove the plenum chamber cover ⇒ Body Work; Rep. gr. 66 .



- Carefully lever the angled pieces off the spray nozzles from below and disconnect the plug connections (of the heated nozzles).
- Unclip the nozzles from the cooling water tank cover.



Note

The spray nozzles can be adjusted. Adjust the spray nozzles ⇒ Maintenance ; Booklet Octavia II .

Installing

The installation occurs in reverse order.

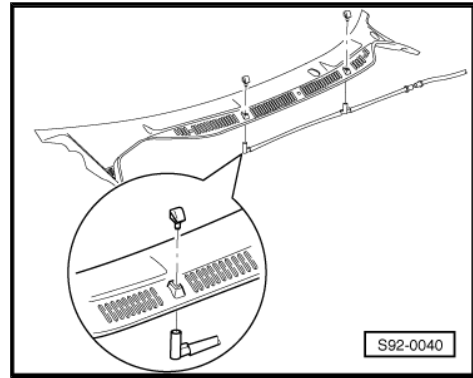

1.3 Removing and installing rear window spray nozzle Octavia

Removing

- Run wiper until it is in park position.
- Open cap of rear window wiper.
- Carefully pull out the spray nozzle in -the direction of arrow-

Installing

- Push spray nozzle fully into the wiper arm shaft so that the opening of the spray nozzle is facing parallel to the wiper arm.

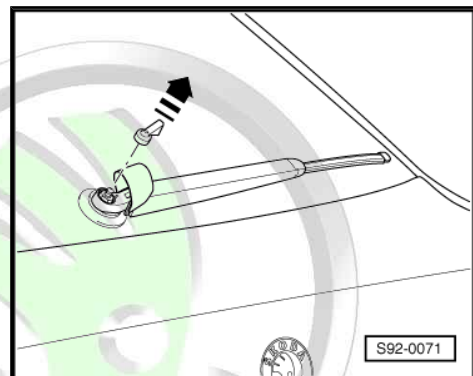

1.4 Removing and installing rear window spray nozzle Octavia Combi

Removing

The spray nozzle is located in the high level brake light.

- Remove high level brake light ⇒ [page 131](#)
- Remove spray nozzle.

Installing

The installation occurs in reverse order.

1.5 Adjusting spray jet

- In middle of swept area.

1.6 Repairing washer fluid lines

All notes and comments to this chapter can be found in the Workshop Manual ⇒ Electrical system - General notes ⇒ Electrical system - General notes; Rep. gr. 92 .

2 Windscreen Wiper and Washer System

⇒ [“2.1 Windscreen wiper and washer system”, page 85](#)

⇒ [“2.2 Removing and installing rear window wiper”, page 89](#)

⇒ [“2.3 Removing and installing Sensor for rain and light detection G397”, page 92](#)

2.1 Windscreen wiper and washer system

⇒ [“2.1.1 General description”, page 85](#)

⇒ [“2.1.2 Fault recognition and fault display, coding”, page 85](#)

⇒ [“2.1.3 Removing and installing the wiper arms with wiper blades and setting their final setting”, page 85](#)

⇒ [“2.1.4 Removing and installing wiper motor with linkage”, page 87](#)

⇒ [“2.1.5 Removing and installing wiper motor from linkage”, page 87](#)

2.1.1 General description

- ◆ Description of the system and the function ⇒ Self-study programme No. 54 ; Skoda Octavia II Electrical Components .
- ◆ The wiper motor control unit - J400- and the windscreen wiper motor - V- are installed as one component and cannot be replaced separately.
- ◆ To remove the wiper blades the wiper arms must be moved into the “service/winter position”. Service / winter position is activated by positioning the windscreen wiper lever within 10 seconds after switching off the ignition in position “flick wipe”. Further information ⇒ Owner's manual Octavia II .

2.1.2 Fault recognition and fault display, coding

The vehicle voltage control unit - J519-, which regulates the functions of the windscreen wiper and washer system, is equipped with self-diagnosis which facilitates the fault finding.

Use the ⇒ Vehicle diagnostic tester for troubleshooting and coding.

2.1.3 Removing and installing the wiper arms with wiper blades and setting their final setting



Note

If the wiper motor is switched on during work, the front flap must be closed and the ignition must be switched on, otherwise the voltage supply of the wiper motor is interrupted.

Special tools and workshop equipment required

- ◆ Extractor for wiper arms - T10369/1-

Removing

- Switch off the ignition and all electrical consumers!



- Use a screwdriver to lever off the two caps on the wiper arms.
- Unscrew the nuts -arrows-.

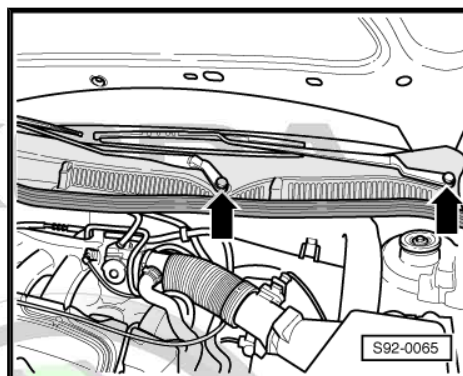

- Push the extractor -2- for wiper arms -T10369/1- , as shown, onto the arm.



Note

To release the windscreen wiper arms, always use the thrust piece -3- in order to avoid damage to the thread of the wiper motor shaft.

- Release the wiper arm -4- from the shaft by turning the pressure screw -1-.

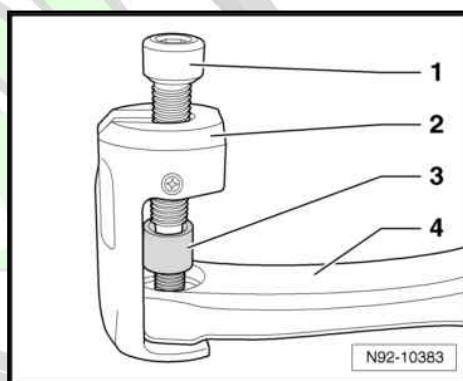

Installing



Note

Protected by copyright. Copying for private or commercial purposes, in part or in whole, is not permitted unless authorised by ŠKODA AUTO A. S. ŠKODA AUTO A. S. does not guarantee or accept any liability with respect to the correctness of information in this document. Copyright by ŠKODA AUTO A. S. ©

- ◆ *When switching off for the second time, the wiper motor overruns in the offset final setting so that the wiper blade lip is controlled in the other direction.*
 - ◆ *The wiper motor runs downwards and then again a little upwards. This offset final setting cannot be used to compensate for the windscreen wiper crank.*
 - ◆ *The final setting must be used in which the wiper motor runs directly and without overrun in the lower final setting. If the wiper motor runs in the offset final setting, wiping must be switched on again.*
 - ◆ *Function of the offset final setting is active only after 100 wiper cycles as of coding or installation of a new wiper motor. If this function is already activated, it can be determined by switching on and off the wiper motor repeatedly.*
- Switch wiper motor on and off and run until it is in park position for setting the windscreen wiper arms.

- Insert windscreen wiper arms with wiper blades and align wiper blades to the markings in the windscreen -1-.
- Slightly tighten fixing nuts.
- Operate the flick wipe and check again or correct the setting of the wiper arms.
- Tighten securing nuts (17 Nm).

i Note

The tolerance between wiper blade and marking -1- is ± 3 mm.

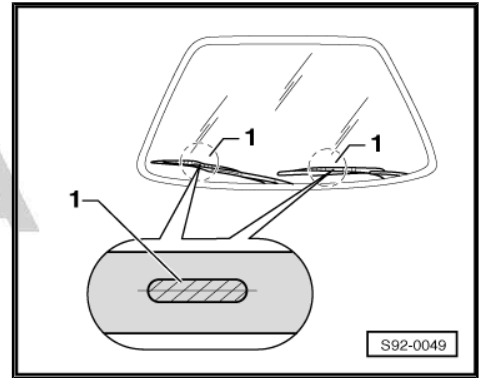

2.1.4 Removing and installing wiper motor with linkage

Removing

- Switch off the ignition and all electrical consumers!
- Remove wiper arms with wiper blades \Rightarrow page 85 .
- Remove the plenum chamber cover \Rightarrow Body Work; Rep. gr. 66 .
- Unplug connector -1- at wiper motor.
- Release screws -arrows- (10 Nm).
- Place wiring loom down to the side.
- Removing wiper motor with linkage -2-

Installing

Installation is carried out in the reverse order. When installing, observe the following:

- When installing the rig pin -2- correctly insert into rubber bearing -1- in the body.

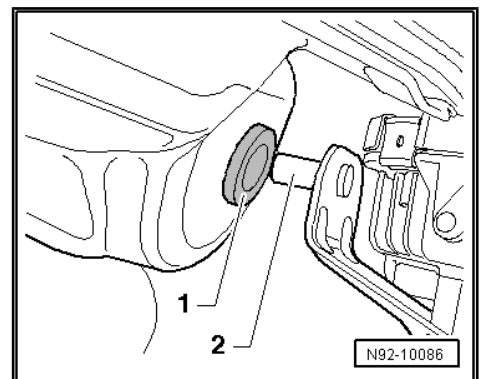
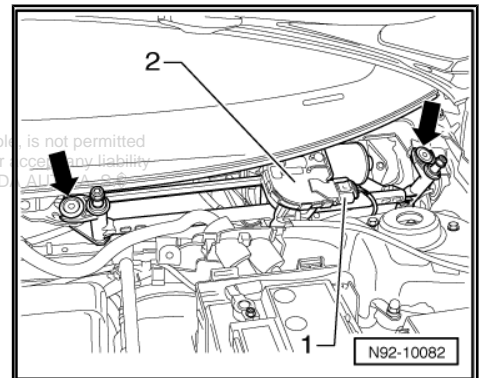

2.1.5 Removing and installing wiper motor from linkage

Removing

Special tools and workshop equipment required

- ◆ Disassembly tool for door panel - MP8-602/1-

- Use a removal tool -MP8-602/1- to lever off the rod -1- from joint holder -arrow-.

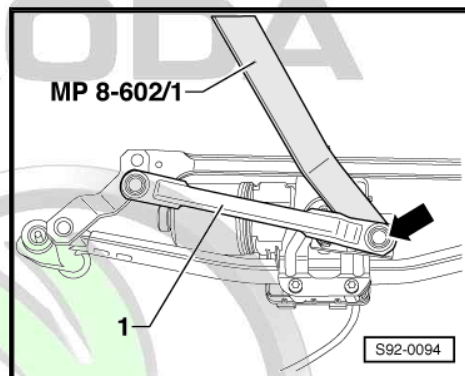

- Release fixing nut -1- (18 Nm) and detach engine crank -2- from the wiper motor shaft.
- Unscrew fixing screws -arrows- (8 Nm) and remove the wiper motor with control unit from the installation slot.

Installing



Note

- ◆ *If the wiper motor is switched on during work, the front flap must be closed and the ignition must be switched on, otherwise the voltage supply of the wiper motor is interrupted.*
 - ◆ *When switching off for the second time, the wiper motor overruns in the offset final setting so that the wiper blade lip is controlled in the other direction.*
 - ◆ *The wiper motor runs downwards and then again a little upwards. This offset final setting cannot be used to compensate for the windscreen wiper crank.*
 - ◆ *The final setting must be used in which the wiper motor runs directly and without overrun in the lower final setting. If the wiper motor runs in the offset final setting, wiping must be switched on again.*
 - ◆ *Function of the offset final setting is active only after 100 wiper cycles as of coding or installation of a new wiper motor. If this function is already activated, it can be determined by switching on and off the wiper motor repeatedly.*
- First of all plug in the connector to the wiper motor and run it until it is in lower park position by operating the wiper switch.
 - Unplug the connector again and attach the wiper motor with the securing screws -arrows- (8 Nm).

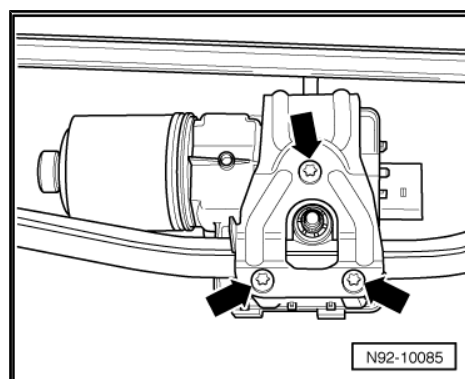
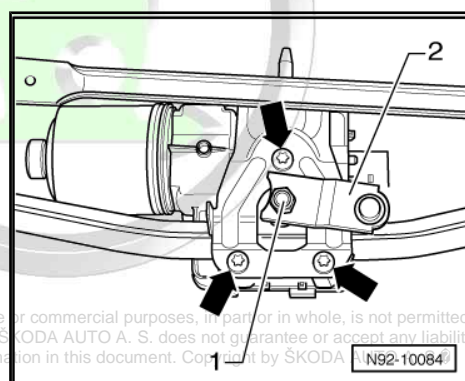

- Insert crank -1- at wiper motor shaft. The distance -a- from stop -2- must be 3 ± 1 mm.
- Tighten nut -3- (18 Nm).

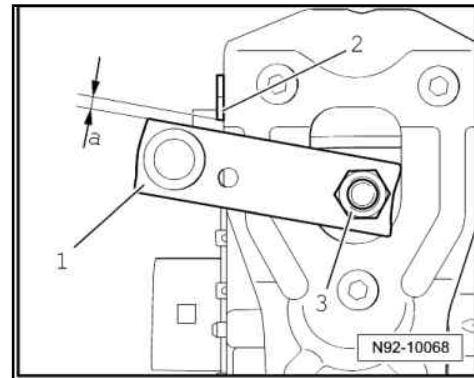

- Press rod -1- onto the joint holder -arrow-.

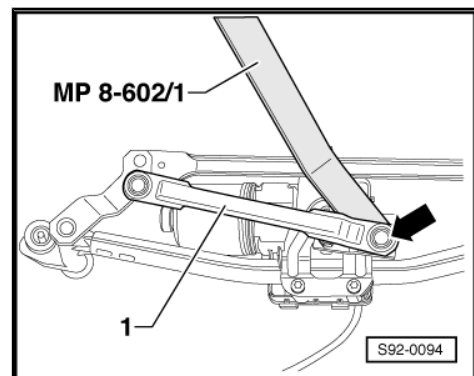

ŠKODA

2.2 Removing and installing rear window wiper

⇒ [“2.2.1 Removing and installing the wiper arm with wiper blade and setting its final setting”, page 89](#)

⇒ [“2.2.2 Removing and installing rear window wiper motor, Octavia”, page 90](#)

⇒ [“2.2.3 Removing and installing rear window wiper motor Octavia Combi”, page 91](#)

2.2.1 Removing and installing the wiper arm with wiper blade and setting its final setting

Protected by copyright. All rights reserved. Reproduction is permitted unless authorised by SKODA AUTO A. S. SKODA AUTO A. S. does not guarantee or accept any liability with respect to the correctness of information in this document. Copyright by ŠKODA AUTO A. S.

Removing



Note

The procedure for removing and installing the wiper arm with the wiper blade on Octavia Combi is similar.

- Raise cap.

- Carefully pull out the spray nozzle in -the direction of arrow-.

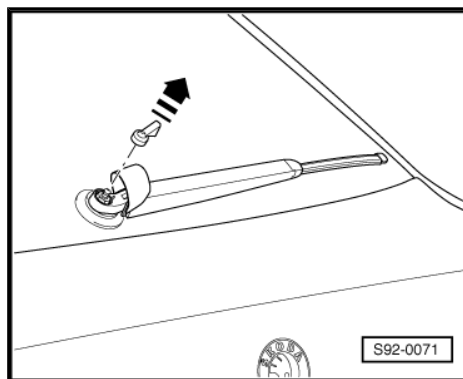

- Loosen the nut -arrow-.
- To loosen the wiper arm from the cone, use a small commercially available two-arm extractor.
- Unscrew nut and remove wiper arm with wiper blade.

Installing

- Switch wiper motor on and off again and run until it is in park position.
- Fit the wiper arm with wiper blade and set the final setting:

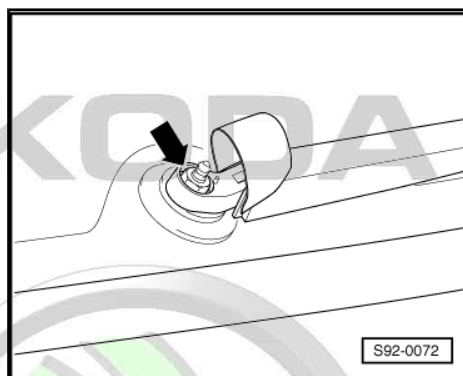

Octavia:

The distance -a- between the wiper blade and the lower edge of the rear window is 36 mm

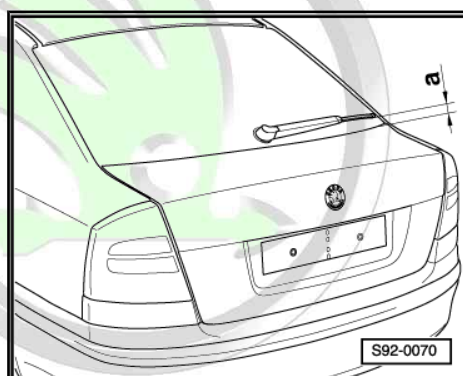

Octavia Combi:

The distance -a- between the wiper blade and the lower edge of the rear window is 22 mm

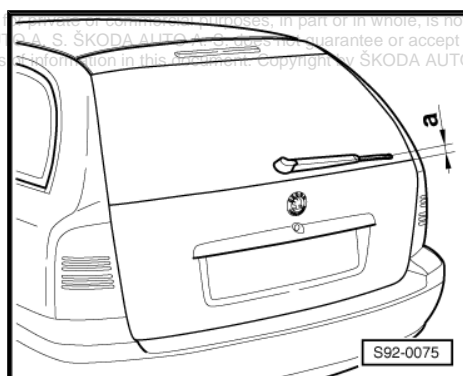

- Slightly tighten fixing nut.
- Operate the flick wipe and check again or correct the setting of the wiper arm.
- Tighten fixing nut (12 Nm).

2.2.2 Removing and installing rear window wiper motor, Octavia

Removing

- Switch off the ignition and all electrical consumers!
- Remove wiper arm with wiper blade => [page 89](#) .

- Remove the bottom tailgate trim panel ⇒ Body Work; Rep. gr. 70 .
- Unplug connector -1- at wiper motor.
- Detach hose -2- to spray nozzle.
- Unscrew nuts/screws (7 Nm) -arrows- and remove wiper motor.

Installing

Installation is carried out in the reverse order. When installing, observe the following:

- Take fitting position of implementation into account. Recess in the rear window implementation -arrow- points downwards, see Fig.

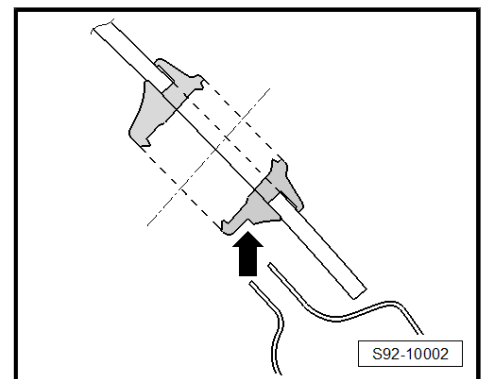
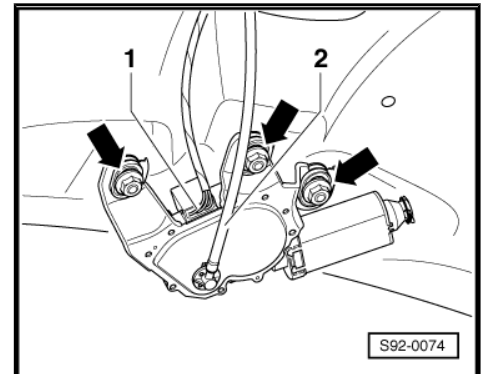

2.2.3 Removing and installing rear window wiper motor Octavia Combi

Removing

- Switch off the ignition and all electrical consumers!
- Remove wiper arm with wiper blade ⇒ [page 89](#) .
- Remove the bottom tailgate trim panel ⇒ Body Work; Rep. gr. 70 .
- Unplug connector -1- at wiper motor.
- Unscrew nuts (7 Nm) -arrows- and remove wiper motor.

Installing

Installation is carried out in the reverse order. When installing, observe the following:

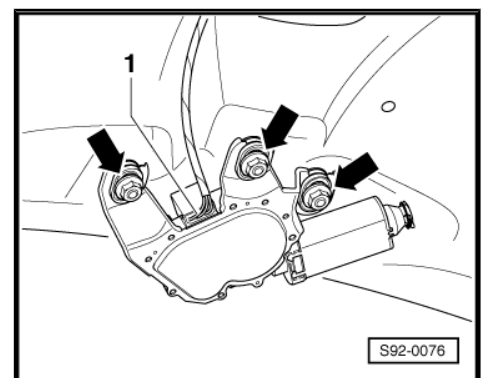
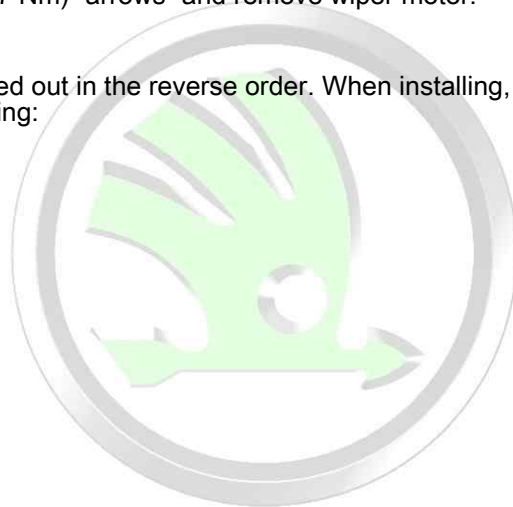



- Take fitting position of implementation into account. Recess in the rear window implementation -arrow- is located at the bottom from the inside, see Fig.

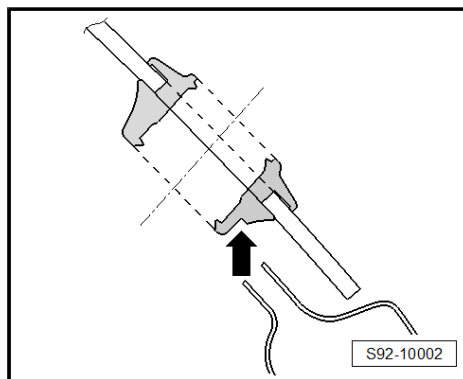

ŠKODA

2.3 Removing and installing Sensor for rain and light detection - G397-



Caution

If the sensor for rain and light detection - G397- is removed from the retaining plate on the windscreen (e.g. when changing the windscreen), it can be subsequently installed again. Store the removed sensor dust-free until it is installed again and make sure that the silicone coupling cushion does not get dirty.

Removing

- Switch off all electrical components and take out the ignition key.
- Removing interior rear-view mirror ⇒ Body Work; Rep. gr. 68 .
- Disconnect plug -1- from sensor -2-.

Protected by copyright. Copying for private or commercial purposes, in part or in whole, is not permitted unless authorised by ŠKODA AUTO A. S. ŠKODA AUTO A. S. does not guarantee or accept any liability with respect to the correctness of information in this document. Copyright by ŠKODA AUTO A. S. ©

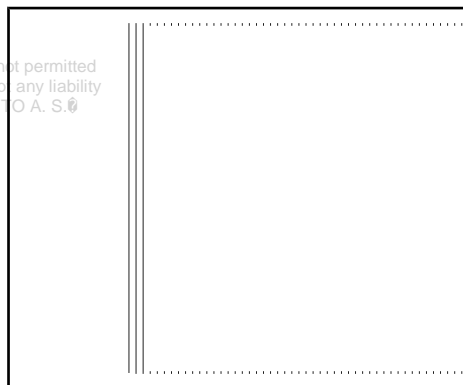

- Lever the sensor -1- carefully and slowly from the retaining plate -2- at the recess -3- using a suitable cross-head screwdriver.

i Note

When removing, make sure to lever off the complete sensor and not only the upper shell of the sensor.

Installing

Installation is carried out in the reverse order. When installing, observe the following:



Caution

- ◆ *Thoroughly clean the windscreen inside the retaining plate with e.g. isopropyl (technical alcohol).*
- ◆ *The surface (coupling cushion) of the sensor must not get dirty or damaged when installing. A sensor with a damaged coupling cushion must be replaced.*

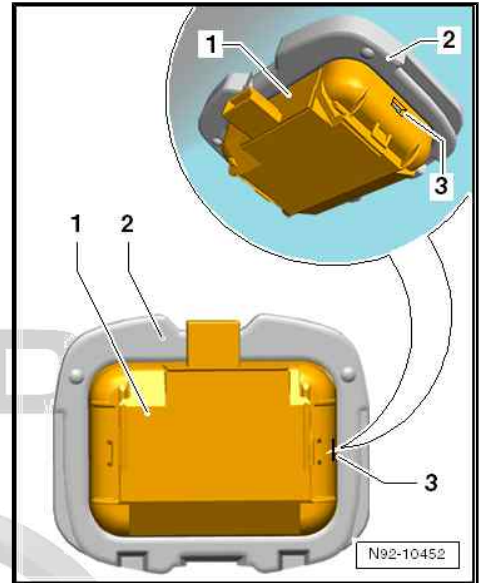

i Note

If the surface (coupling cushion) of the sensor is dirty, it can be cleaned, if necessary, by sticking on one or several adhesive tapes and then pulling them off again.

- If necessary, remove the protective cap of the new sensor.
- Insert the sensor -1- into the retaining plate on the windscreen -2- and press firmly.

i Note

- ◆ *Even after correct installation of the sensor, smaller air bubbles can be present initially between the windscreen and the coupling cushion. The contact surface must be free of bubbles after approx. 10 minutes.*
- ◆ *When replacing, the new sensor must be coded with the → Vehicle diagnostic tester.*

Protected by copyright. Copying for private or commercial purposes, in part or in whole, is not permitted unless authorised by ŠKODA AUTO A. S. ŠKODA AUTO A. S. does not guarantee or accept any liability with respect to the correctness of information in this document. Copyright by ŠKODA AUTO A. S. ©

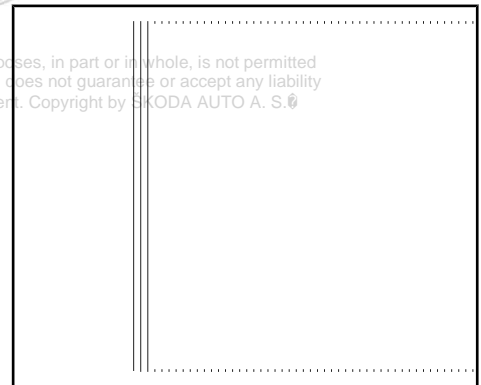

3 Headlamp cleaning system

Summary of components - Components of the headlight washing system ⇒ Electronic Catalogue of Original Parts .

⇒ [“3.1 Removing and installing headlight cleaning system pump V11”](#), page 94

⇒ [“3.2 Removing and installing the lift cylinder for spray nozzles of headlights - vehicles up to MY 08”](#), page 94

⇒ [“3.3 Removing and installing spray nozzle holder - vehicles as of MY 09”](#), page 95

⇒ [“3.4 Removing and installing the lift cylinder for spray nozzles of headlights - vehicles as of MY 09”](#), page 96

⇒ [“3.5 Bleed the headlamp cleaning system”](#), page 96

3.1 Removing and installing headlight cleaning system pump - V11-

The removal and installation of the pump is described in ⇒ [page 82](#) .

After installing the pump bleed the headlamp cleaning system ⇒ [page 96](#) .

3.2 Removing and installing the lift cylinder for spray nozzles of headlights - vehicles up to MY 08

Removing

- Pull the spray nozzles with cover -1- slightly out of the bumper by uniformly gripping on both sides of the cover, then grip the spray nozzles -2- and pull out up to the stop.
- Release catches -arrows- and slide out the cover from the spray nozzles.
- Remove front bumper ⇒ Body Work; Rep. gr. 63 .

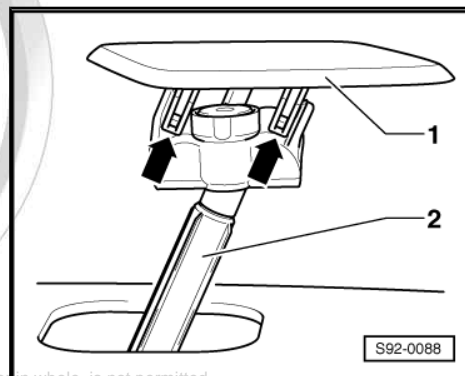

- To unlock press the securing clamp -2- and pull off hose with coupling -1- from the lift cylinder for spray nozzles -3-.
- Screw out the screw -arrows- (2 Nm) and remove the lift cylinder.

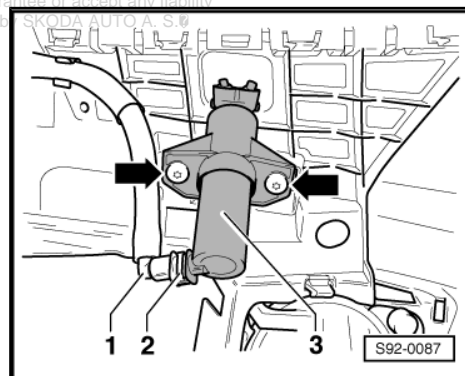

Installing

Installation is carried out in the reverse order. When installing, observe the following:

- Insert lift cylinder for spray nozzles and tighten so that the cover of the spray nozzles covers the opening in the bumper (must be performed before installation).
- Hoses with angled pieces must click audibly into the connections on the lift cylinders for spray nozzles.
- After completing the assembly work bleed the headlamp cleaning system ⇒ [page 96](#) .

3.3 Removing and installing spray nozzle holder - vehicles as of MY 09



Caution

The spray nozzles should not be pulled out by hand.

Depending on the version, the pulled out cylinder piston can tilt during the return stroke.

It is not allowed to insert the cylinder piston by hand as this results in damage to the lift cylinder for the headlamp cleaning system.

A jammed piston in the cylinder becomes functional if it is activated by the system which is determined for this, i.e. by water pressure.

Only move out the spray nozzles by water or air pressure.

Removing

- Push out the spray nozzles by means of fluid pressure or compressed air and then collect (second mechanic is required). Do not pull out by hand!
- Press off the catch -arrow A- using a small screwdriver and push the spray nozzle holder -2- with the cover -1- out of the lift cylinder -3-.
- If necessary, loosen the cover of the spray nozzles -1- from the catches -arrows B- and remove.

Installing



Note

Catches on the spray nozzle are intended to push the cover for the spray nozzle holder into the bumper as far as possible. If the spray nozzle holder is pushed too far into the lift cylinder for spray nozzles, the cover or the bumper can be deformed. If the spray nozzle holder is pushed in a little, there is a gap between the cover and the bumper.

- Clip cover onto the holder.
- Push the holder with cover into the lift cylinder for spray nozzles until the cover is tightly fit on the bumper.
- After installing the holder bleed the headlamp cleaning system [⇒ page 96](#).

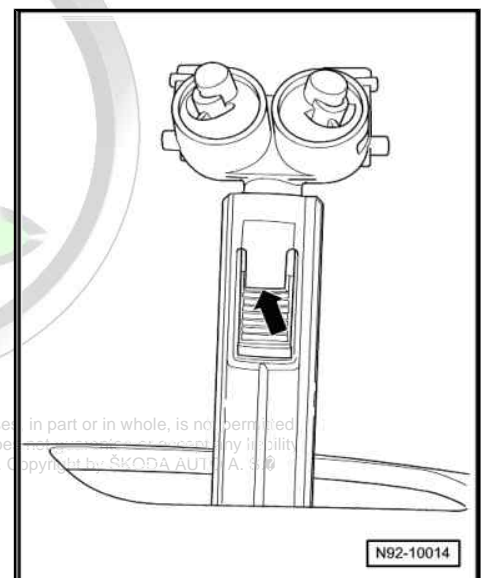
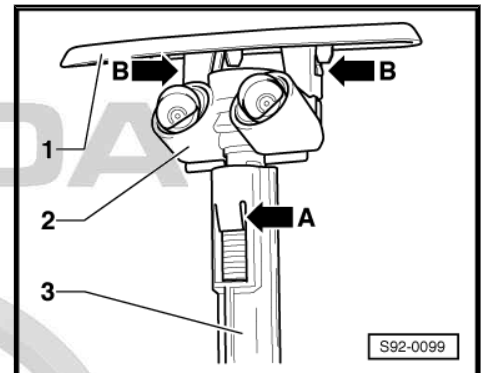

3.4 Removing and installing the lift cylinder for spray nozzles of headlights - vehicles as of MY 09

Removing

- Remove spray nozzle holder ⇒ [page 95](#) .
- Remove front bumper ⇒ Body Work; Rep. gr. 63 .
- Press off the catches -arrows A- using a small screwdriver and push the lift cylinder -1- out of the bumper -arrow B-.

Installing

Installation is carried out in the reverse order. When installing, observe the following:

- Push the lift cylinder into the brackets in the bumper until it clicks audibly into place.
- Observe correct mounting sequence of spray nozzle holder ⇒ [page 95](#) .
- Hoses with angled pieces must click audibly into the connections on the lift cylinders for spray nozzles.
- Install bumper.
- After completing the assembly work bleed the headlamp cleaning system ⇒ [page 96](#) .

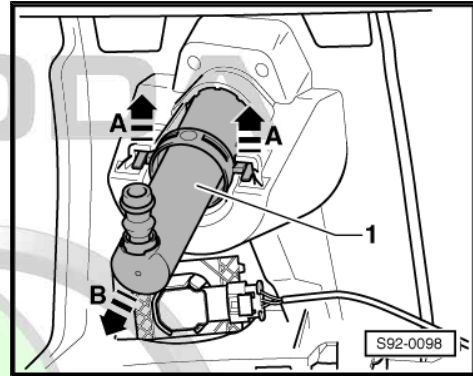

3.5 Bleed the headlamp cleaning system

After installation or for initial setup, the headlamp cleaning system must be bled to guarantee a perfect operation.

- Fill washer fluid reservoir and headlight washer reservoir.
- Start engine.
- Switch on headlight.
- Operate headlamp cleaning system several times (3 – 5 pulses for an operating duration of 3 s each).
- If necessary repeat this bleeding procedure until a perfect functioning of the lift cylinders for headlamp cleaning system and for spray nozzles is achieved.

Protected by copyright. Copying for private or commercial purposes, in part or in whole, is not permitted unless authorised by ŠKODA AUTO A. S. ŠKODA AUTO A. S. does not guarantee or accept any liability with respect to the correctness of information in this document. Copyright by ŠKODA AUTO A. S. ©

94 – Lights, bulbs, switches - exterior

1 Headlights – halogen headlights

⇒ [“1.1 Summary of components headlights - vehicles up to MY 08 and Octavia Tour”, page 97](#)

⇒ [“1.2 Summary of components of headlights - vehicles as of MY 09 \(except Octavia Tour\)”, page 98](#)

⇒ [“1.3 Removing and installing headlight”, page 99](#)

⇒ [“1.4 Setting the headlight beam”, page 99](#)

⇒ [“1.5 Replacing light bulbs in the headlight - vehicles up to MY 08 and Octavia Tour”, page 100](#)

⇒ [“1.6 Replacing light bulbs in the headlight - vehicles as of MY 09 \(except Octavia Tour\)”, page 102](#)

⇒ [“1.7 Change headlight for right-hand / left-hand traffic”, page 104](#)

1.1 Summary of components headlights - vehicles up to MY 08 and Octavia Tour

1 - Headlight housing

- Removing and installing
⇒ [page 99](#)
- Adjust ⇒ [page 99](#)

2 - Light bulb for the turn signal light

- Light bulb PY21W, 12 V, 21 W
- Replace ⇒ [page 101](#)

3 - Lamp socket for the turn signal light

4 - Light bulb for the parking light

- Light bulb W5W, 12 V, 5 W
- Replace ⇒ [page 101](#)

5 - Light bulb for low beam light

- Light bulb H7, 12 V, 55 W
- Replace ⇒ [page 100](#)

6 - Light bulb for main beam

- Light bulb H1, 12 V, 55 W
- Replace ⇒ [page 101](#)

7 - Cover

8 - Cover

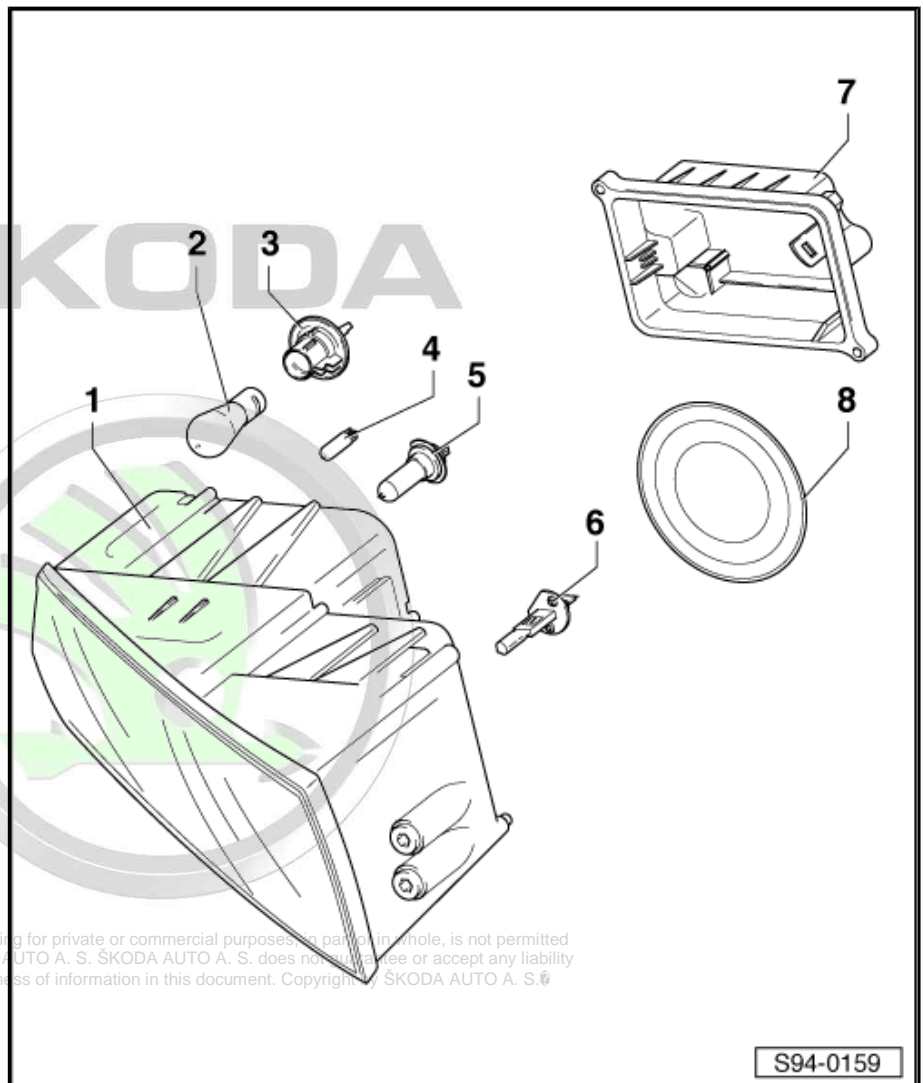

Protected by copyright. Copying for private or commercial purposes, in part or in whole, is not permitted unless authorised by ŠKODA AUTO A. S. ŠKODA AUTO A. S. does not guarantee or accept any liability with respect to the correctness of information in this document. Copyright © ŠKODA AUTO A. S.®

S94-0159



Note

The headlight range control motor is an integral part of the headlight. The headlight must be replaced if any defects arise.

1.2 Summary of components of headlights - vehicles as of MY 09 (except Octavia Tour)

1 - Headlight housing

- Removing and installing ⇒ [page 99](#)
- Adjust ⇒ [page 99](#)

2 - Light bulb for the turn signal light

- Light bulb PY21W, 12 V, 21 W
- Replace ⇒ [page 101](#)

3 - Lamp socket for the turn signal light

4 - Cover

5 - Lifting eye

6 - Light bulb for low beam light

- Light bulb H7, 12 V, 55 W
- Replace ⇒ [page 100](#)

7 - Light bulb for the parking light

- Light bulb W5W, 12 V, 5 W
- Replace ⇒ [page 101](#)
- Vehicles "RS" as of CW 22.09 - light bulb not operational, parking light in individual multifunctional lamp with LED diodes via fog light see ⇒ [page 130](#)

8 - Light bulb for main beam

- Light bulb H1, 12 V, 55 W
- Replace ⇒ [page 101](#)

9 - Cover

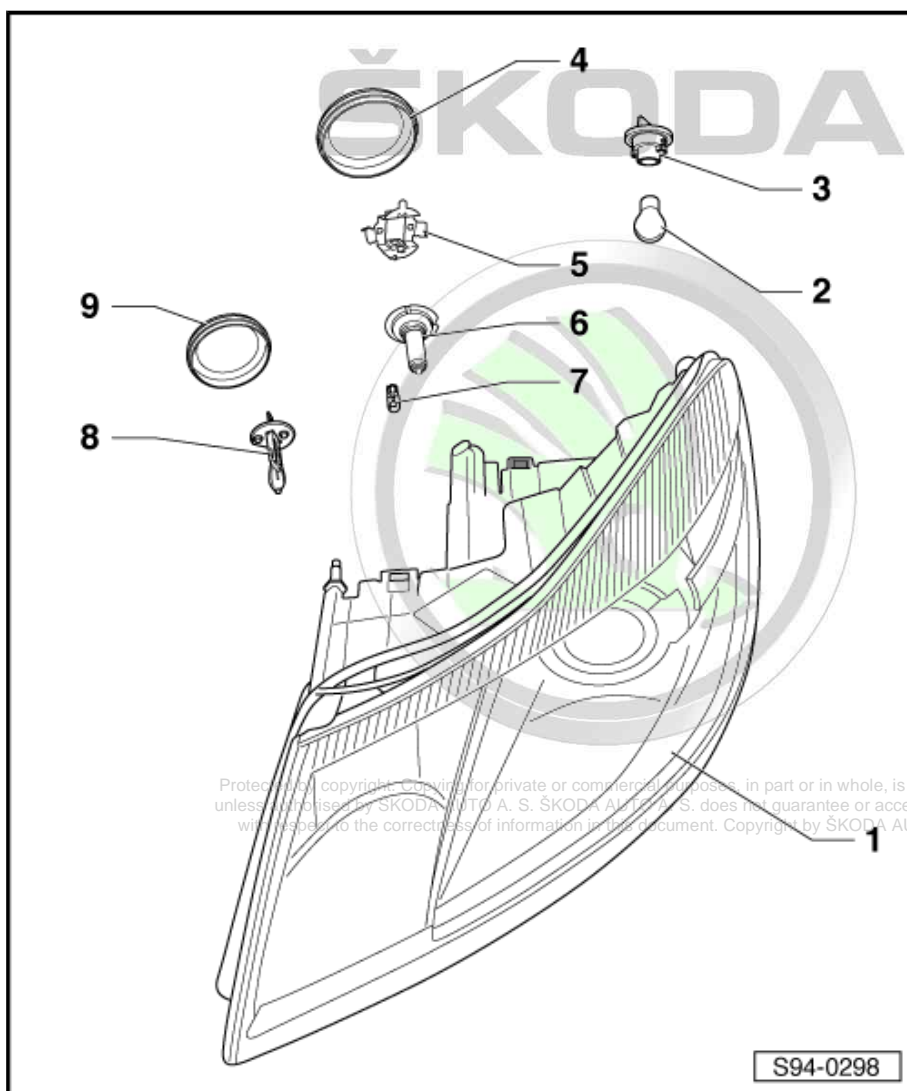

Protected copyright. Copying for private or commercial purposes, in part or in whole, is not permitted unless authorised by SKODA AUTO A. S. SKODA AUTO A. S. does not guarantee or accept any liability with respect to the correctness of information in this document. Copyright by SKODA AUTO A. S.



Note

The headlight range control motor is an integral part of the headlight. The headlight must be replaced if any defects arise.

1.3 Removing and installing headlight

Removing



Note

The removal and installation will be demonstrated using the example of the right-hand headlight. The procedure for removal and installing is identical for the left headlight.

- Switch off the ignition and all electrical consumers!
- Remove nut -1- (1 Nm).
- Slightly raise the catch -2- and slacken the headlight by pulling -arrow- on the lever -3-.
- Carefully push the headlight towards the front, for this step disconnect the plug.

Installing

- Align the headlight according to the contours of the vehicle body (maintain the gap size ⇒ Body Repairs; Rep. gr. 00) and fix in place.

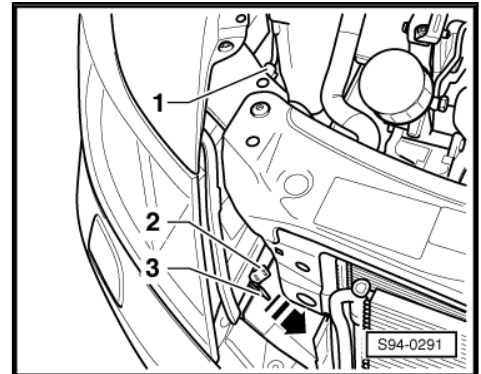

Note

- ◆ The headlight carrier -1- can be moved longitudinally as well as laterally after releasing the fixing screws -2- and -3-.
- ◆ By turning the positioning elements in anti-clockwise direction the plate is lifted (lowered in clockwise direction) and thus also adjusted vertically.
- ◆ After the headlight carrier -1- has been correctly positioned, tighten the fixing screws -2- and -3- to the prescribed tightening torque of 5 Nm.

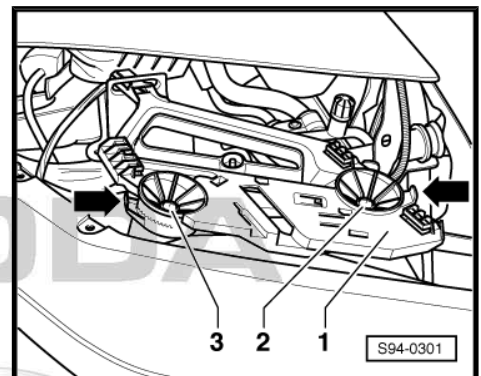

- Mount plug.
- Push the headlight into the headlight carrier and lock it by inserting the lever.
- Determine the distance to the stop of the screw -1- by turning -arrow A- until it rests on the headlight carrier.
- Then tighten the fixing nut -2- -arrow B- (1 Nm).
- Set up the headlight ⇒ [page 99](#) .

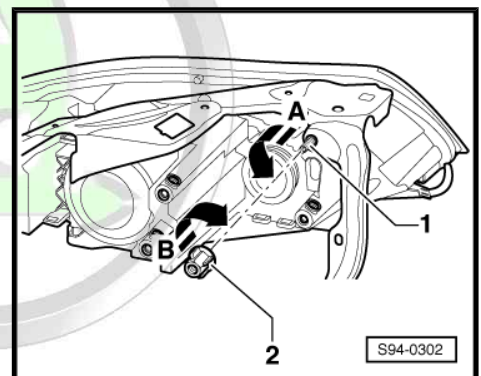

1.4 Setting the headlight beam

Use a headlight beam setting device for setting the headlight beam. Specified values, setting elements, conditions and measurement ⇒ Maintenance ; Booklet Octavia II .



1.5 Replacing light bulbs in the headlight - vehicles up to MY 08 and Octavia Tour



WARNING

H1 and H7 bulbs are pressurized and can burst when changing the bulb. It is recommended to wear gloves and safety glasses when changing bulbs.



Note

- ◆ Do not touch the glass when installing the light bulb. Your fingers will leave traces of grease on the glass which then evaporate when the bulb is switched on causing it to cloud.
- ◆ Pay attention to the correct fitting of the rubber caps and the correct positioning as well as the undamaged seals on the plastic covers. Water ingress destroys the headlight.

– Remove headlight ⇒ [page 99](#).

⇒ [“1.5.1 Replacing bulb for low beam light”, page 100](#)

⇒ [“1.5.2 Replacing bulb for the parking light”, page 101](#)

⇒ [“1.5.3 Replacing bulb for the turn signal light”, page 101](#)

⇒ [“1.5.4 Replacing bulb for the main beam”, page 101](#)

1.5.1 Replacing bulb for low beam light

– Release springs and remove cover -2-.

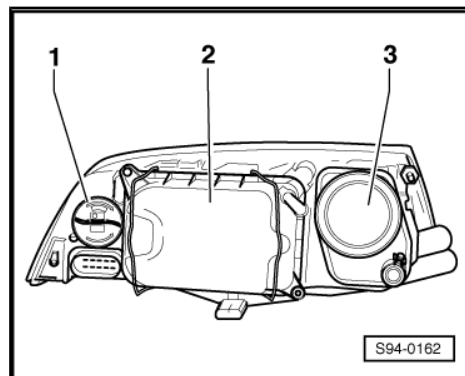

– Disconnect plug connection -2-.

– Release the wire spring clamp and remove the light bulb from the headlight housing.

– The installation occurs in reverse order.

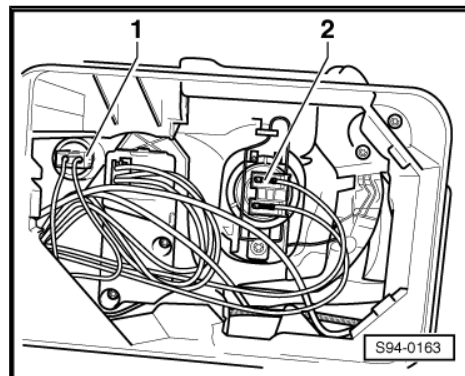

1.5.2 Replacing bulb for the parking light

- Release springs, on vehicles with Xenon discharge lamps screw out the screws -arrows- (1 Nm) and remove the cover -2-.

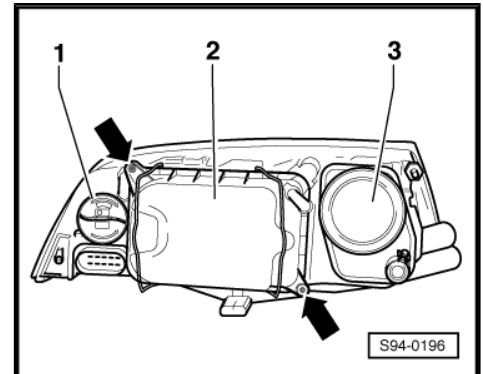

- Pull out the light bulb with socket -1- at the connector.
- Remove the bulb from the socket.
- After replacing the bulb, press socket and bulb fully into the headlight.
- The installation occurs in reverse order.

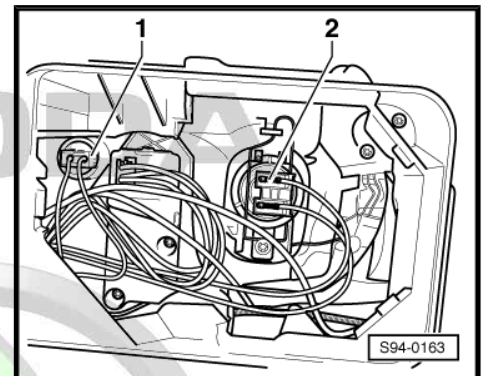

1.5.3 Replacing bulb for the turn signal light

- Remove bulb socket -1- by turning in the direction of the arrow "OPEN".
- Remove the bulb from the socket.
- The installation occurs in reverse order.

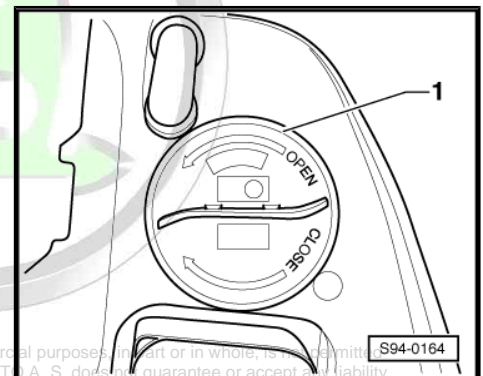

1.5.4 Replacing bulb for the main beam

- Remove cover -3-.

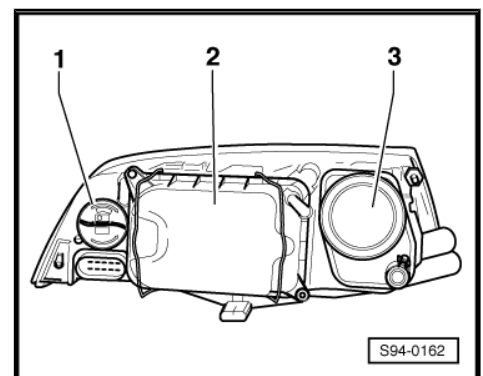

Protected by copyright. Copying for private or commercial purposes, in part or in whole, is not permitted, unless authorised by ŠKODA AUTO A. S. ŠKODA AUTO A. S. does not guarantee or accept any liability with respect to the correctness of information in this document. Copyright by ŠKODA AUTO A. S. ©

- Disconnect plug connection -1-.
- Release the wire spring clamp -2- and remove the light bulb.
- The installation occurs in reverse order.

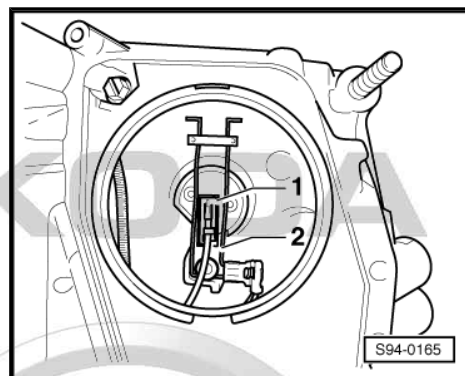

1.6 Replacing light bulbs in the headlight - vehicles as of MY 09 (except Octavia Tour)



WARNING

H1 and H7 bulbs are pressurized and can burst when changing the bulb. It is recommended to wear gloves and safety glasses when changing bulbs.



Note

- ◆ *Do not touch the glass when installing the light bulb. Your fingers will leave traces of grease on the glass which then evaporate when the bulb is switched on causing it to cloud.*
- ◆ *Pay attention to the correct fitting of the rubber caps on the headlight. Water ingress destroys the headlight.*

- Remove headlight ⇒ [page 99](#) .

⇒ [“1.6.1 Replacing bulb for low beam light”, page 102](#)

⇒ [“1.6.2 Replacing bulb for the parking light”, page 103](#)

⇒ [“1.6.3 Replacing bulb for the main beam”, page 103](#)

1.6.1 Replacing bulb for low beam light

- Remove rubber cap (the larger one) for headlight.
- Turn lifting eye with plug -1- -arrow-.
- Remove bulb with lifting eye and connector from the headlight.

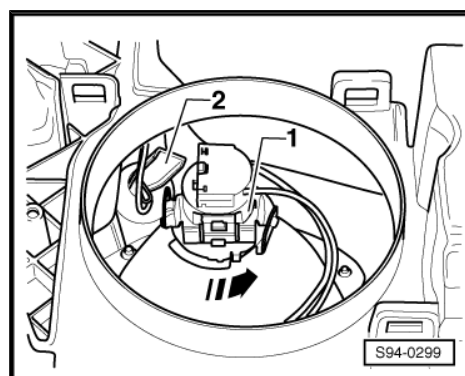

- Remove bulb -1- from the lifting eye with connector -2-.
- The installation occurs in reverse order.

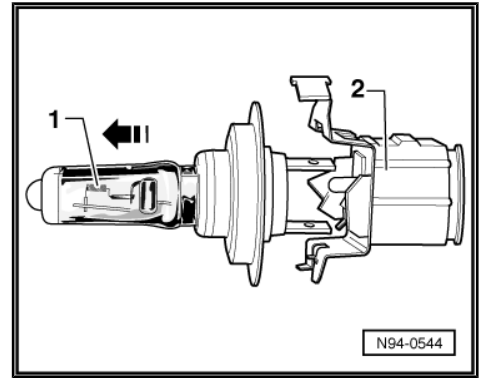

1.6.2 Replacing bulb for the parking light

- Remove rubber cap (the larger one) for headlight.
- Grip the extended bulb socket -2- with pliers and remove it while taking into account the connected cable lengths.

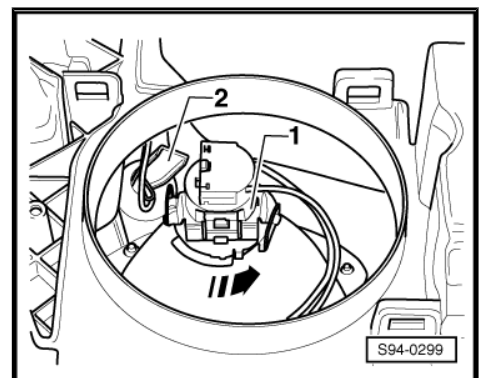

- Remove bulb -2- from holder -1-.
- After replacing the bulb, press socket and bulb fully into the headlight.
- Further installation occurs in reverse order.

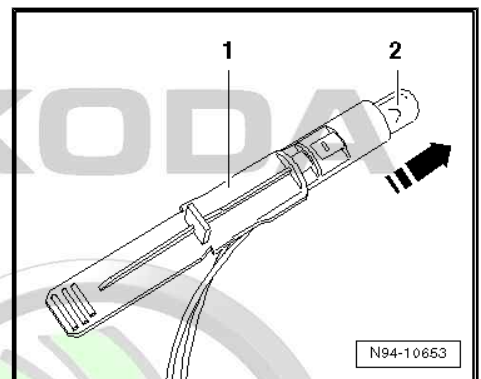

1.6.3 Replacing bulb for the main beam

- Remove rubber cap (the smaller one) for headlight.
- Disconnect plug connection -1-.
- Release the wire spring clamp -2- and remove the light bulb.
- The installation occurs in reverse order.

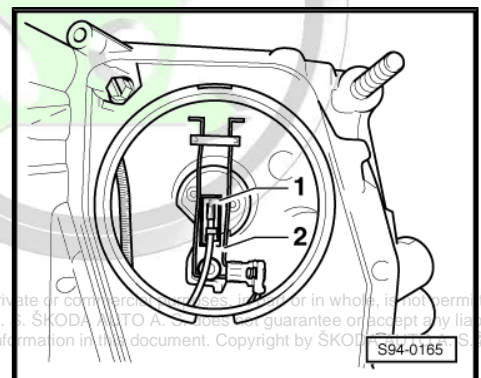

Protected by copyright. Copying for private or commercial purposes, in whole or in part, is not permitted unless authorised by ŠKODA AUTO A. S. ŠKODA AUTO A. S. does not guarantee or accept any liability with respect to the correctness of information in this document. Copyright by ŠKODA AUTO A. S.



1.7 Change headlight for right-hand / left-hand traffic

For trips abroad, both headlights must be changed for the specified traffic direction in the relevant country by an asymmetrical setting of the headlight, thereby preventing blinding of the drivers travelling in the opposite direction.



Note

- ◆ *The change of the headlights is not suitable for the permanent mode, rather only as a brief "touristic" solution during a temporary journey abroad.*
- ◆ *Both headlights must always be changed.*

⇒ ["1.7.1 Switching over the projector headlights - inner aperture for right-hand / left-hand traffic - vehicles up to MY 08 and Octavia Tour", page 104](#)

⇒ ["1.7.2 Switching over the projector headlights - inner aperture for right-hand / left-hand traffic - vehicles as of MY 09 \(except Octavia Tour\)", page 105](#)

⇒ ["1.7.3 Ungluing a halogen headlight for left-hand traffic - vehicles up to MY 08 and Octavia Tour", page 106](#)

1.7.1 Switching over the projector headlights - inner aperture for right-hand / left-hand traffic - vehicles up to MY 08 and Octavia Tour

The headlight inner aperture should be switched over when driving in countries which drive on the right or the left thereby preventing blinding of the drivers travelling in the opposite direction.



Note

Pay attention to the correct fitting and undamaged seals on the plastic covers as well as the correct positioning of the cover. Water ingress destroys the headlight.

Work procedure

- Remove headlight ⇒ [page 99](#) .
- Release springs and remove cover -2-.



Note

It is recommended to remove the light bulb "H7" ⇒ [page 100](#) and to check the correct fitting of the trim after switch-over and by looking into the reflector. The upper edge of the trim -2- is flush with the upper edge of the cover -3- (see figures) after the switch-over.

Left-hand drive in left-hand traffic

The headlight on the left

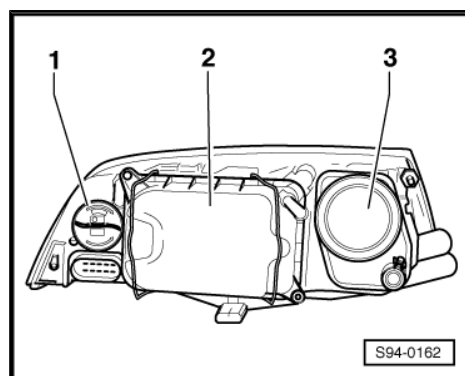

- Insert a small cross-head screwdriver through the opening -arrow- into the hole in the lever -1- slightly press it forward and switch over from the basic position -B- into the position -A-.
- 2- Trim
- 3- Cover

The headlight on the right

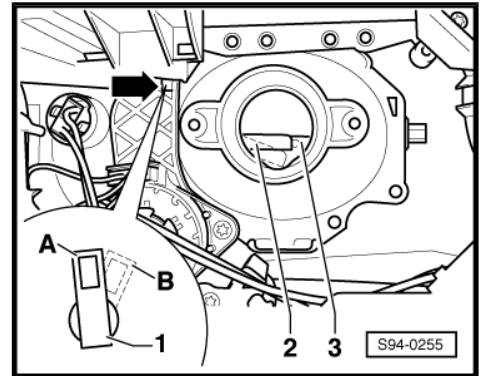

- Insert a small cross-head screwdriver into the hole in the lever -1- slightly press it forward and switch over from the basic position -B- into the position -A-.
- 2- Trim
- 3- Cover

Right-hand drive in right-hand traffic

The headlight on the left

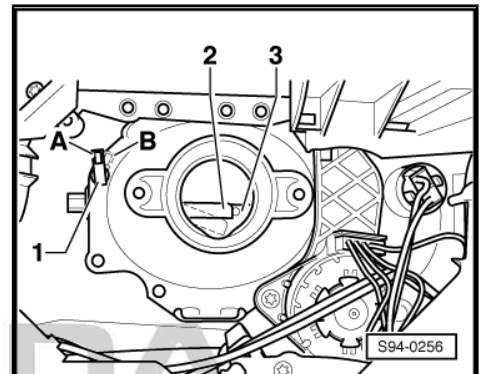

- Insert a small cross-head screwdriver into the hole in the lever -1- slightly press it forward and switch over from the basic position -A- into the position -B-.
- 2- Trim
- 3- Cover

The headlight on the right

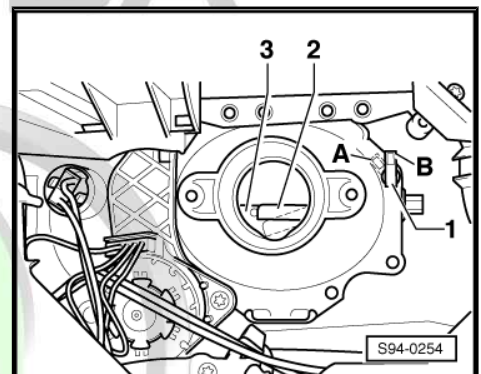

- Insert a small cross-head screwdriver through the opening -arrow- into the hole in the lever -1- slightly press it forward and switch over from the basic position -A- into the position -B-.
- 2- Trim
- 3- Cover

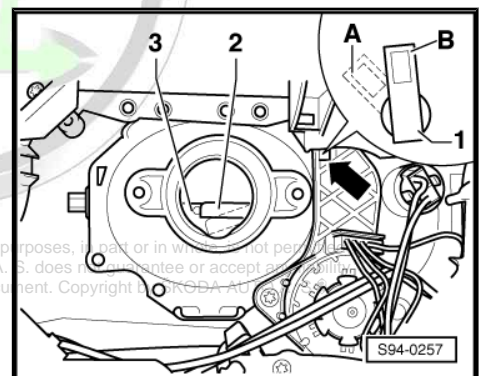

Protected by copyright. Copying for private or commercial purposes, in part or in whole, is not permitted unless authorised by ŠKODA AUTO A. S. ŠKODA AUTO A. S. does not guarantee or accept any liability with respect to the correctness of information in this document. Copyright © ŠKODA AUTO A. S.

1.7.2 Switching over the projector headlights - inner aperture for right-hand / left-hand traffic - vehicles as of MY 09 (except Octavia Tour)

The headlight inner aperture should be switched over when driving in countries which drive on the right or the left thereby preventing blinding of the drivers travelling in the opposite direction.



- Remove rubber cap (the larger one) for headlight.

Right-hand drive in right-hand traffic

- Move the levers connected with each other on the left and right of the bulb -arrows- out of the position -A- into the position -B-.

Left-hand drive in left-hand traffic

- Move the levers connected with each other on the left and right of the bulb -arrows- out of the position -A- into the position -B-.

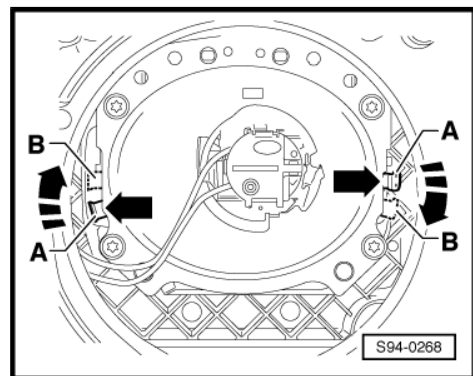
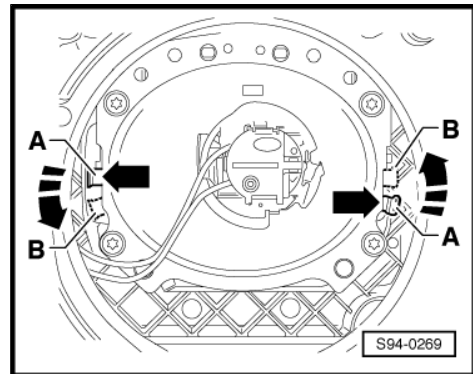

Note

When installing the rubber caps, pay attention to the correct fitting. Water ingress destroys the headlight.

1.7.3 Ungluing a halogen headlight for left-hand traffic - vehicles up to MY 08 and Octavia Tour

The halogen headlights should have self-adhesive foil glued over them when driving in countries which drive on the left thereby preventing blinding of the drivers travelling in the opposite direction.



Note

- ◆ The headlights must be cleared of dirt and de-greased, e.g. with degreased white spirit solution, before sticking the foil.
- ◆ When cleaning and gluing foils, the lens must remain cold for safety reasons.

Work procedure

The headlight on the left

- Only remove protective foil on the reverse side of the foil in the area -1-.
- Glue the self-adhesive foil as shown in the figure, place onto the parting plane -arrow- on the left-hand side of the headlight glass and press forcefully in the area -1-.
- Carefully pull off the -clearer- mounting part of the foil from the lens shown in the figure.
- On the lens there is only the protective foil -1-.

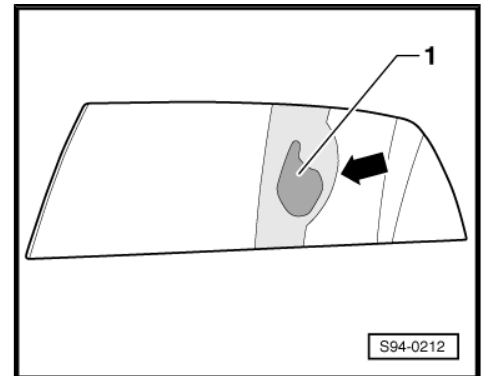

The headlight on the right

- Only remove protective foil on the reverse side of the foil in the area -2-.
- Glue the self-adhesive foil as shown in the figure, place onto the parting plane -arrow- on the right-hand side of the headlight glass and press forcefully in the area -2-.
- Carefully pull off the -clearer- mounting part of the foil from the lens shown in the figure.
- On the lens there is only the protective foil -2-.

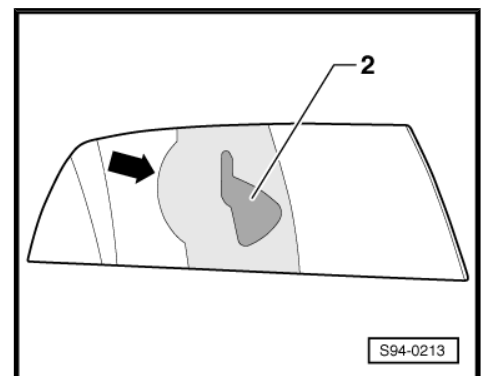

Note

Inform the customer about the corresponding notes for removing the residual adhesive after pulling off the protective foil, e.g. textiles soaked in isopropyl alcohol (do not use any aggressive solvent, which can damage the polycarbonate lenses).



2 Headlights with Xenon discharge lamps



WARNING

Mortal high voltage, risk of injury and risk of pollution.

*Observe use and safety instructions for gas discharge lamps
⇒ Electrical System – general notes; Rep. gr. 94 .*

H1 bulbs are pressurized and can burst when changing the bulb. It is recommended to wear gloves and safety glasses when changing bulbs.



Note

- ◆ *Do not touch the glass when installing the light bulb. Your fingers will leave traces of grease on the glass which then evaporate when the bulb is switched on causing it to cloud.*
- ◆ *Pay attention to the correct fitting and undamaged seals on the plastic covers as well as the correct positioning of the cover. Water ingress destroys the headlight.*
- ◆ *When handling a fault it is absolutely essential to know the function and operation of the illumination system.*
- ◆ *Additional information:*

⇒ Owner's manual Octavia II

⇒ Current flow diagrams, Electrical fault finding and Fitting locations

⇒ [“2.1 Fault recognition and fault display”, page 108](#)

⇒ [“2.2 Headlight with Xenon discharge lamps- vehicles up to MY 08”, page 109](#)

⇒ [“2.3 Headlights with Xenon discharge lamps and cornering light - vehicles as of MY 09”, page 113](#)

⇒ [“2.4 Removing and installing control unit for headlight range control J431 or cornering light and headlight range control unit J745”, page 118](#)

⇒ [“2.5 Removing and installing vehicle level sensor G78 front left or G76 rear left”, page 118](#)

⇒ [“2.6 Contact assignment of plug connection for control unit for headlight range control J431 or cornering light and headlight range control unit J745”, page 119](#)

2.1 Fault recognition and fault display

In case of malfunctions of the headlight range control or the AFS system (Adaptive Frontlighting System) the warning light “light failure” lights up.

The automatic headlight range control (vehicles as of MY 09) and the onboard supply control unit are equipped with the self-diagnosis that facilitates the fault finding of the headlights.

For fault finding use the ⇒ Vehicle diagnostic tester in the function “Targeted fault finding”.

2.2 Headlight with Xenon discharge lamps- vehicles up to MY 08

⇒ [“2.2.1 General description and overall view”, page 109](#)

⇒ [“2.2.2 Summary of components of headlight”, page 109](#)

⇒ [“2.2.3 Replacing Xenon discharge lamp D1S”, page 110](#)

⇒ [“2.2.4 Removing and installing the control unit for a gas discharge lamp”, page 111](#)

⇒ [“2.2.5 Convert headlight for left-hand / right-hand traffic”, page 111](#)

2.2.1 General description and overall view

General description

Vehicles fitted with gas discharge lamps are also fitted with automatic headlight range control as standard. This holds the tilt angle constant on the low beam constant even when the general tilt of the vehicle changes because of the load it is carrying. This system self-diagnostic. Any faults arising (e.g. the gas discharge lamp or the starter device do not work, there is an open circuit in the wiring or a defect on one of the components of the headlight range control) will cause flashing of the indicator light for light failure on the dash panel insert.

A general overview

1 - Headlights with step motors and ignition of the right discharge lamp

2 - Removing and installing automatic regulation control unit
⇒ [page 118](#)

3 - Connection to CAN bus drive

4 - Removing and installing vehicle level sensor on rear axle
⇒ [page 118](#)

5 - Removing and installing vehicle level sensor on front axle
⇒ [page 118](#)

6 - Headlights with step motors and ignition of the left discharge lamp

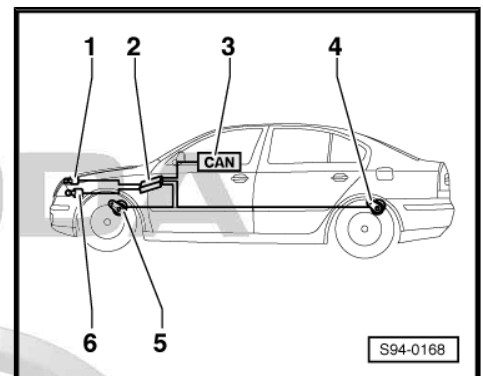

2.2.2 Summary of components of headlight



1 - Headlight housing

- Removing and installing is the same as for the halogen headlight
⇒ [page 99](#)
- Adjust ⇒ [page 99](#)

2 - Light bulb for the turn signal light

- Light bulb PY21W, 12 V, 21 W
- Replace ⇒ [page 101](#)

3 - Lamp socket for the turn signal light

4 - Light bulb for the parking light

- Light bulb W5W, 12 V, 5 W
- Replace ⇒ [page 101](#)

5 - Control unit for the gas discharge lamp

- Removing and installing
⇒ [page 111](#)

6 - Cover

7 - Discharge lamp with integrated high voltage ignition unit

- Type D1S, 35 W
- Replace ⇒ [page 110](#)

8 - High voltage cable

9 - Cover

10 - Light bulb for main beam

- Light bulb H1, 12 V, 55 W
- Replace ⇒ [page 101](#)

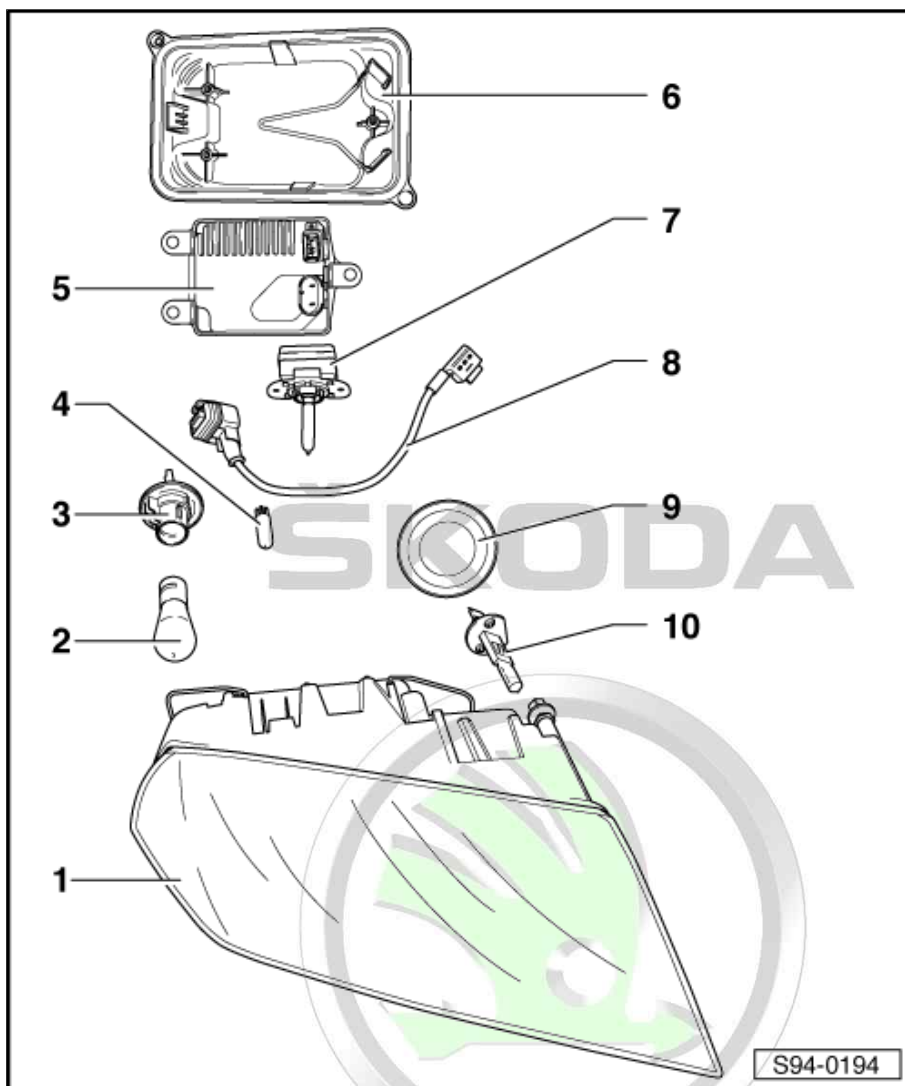

Protected by copyright. Copying for private or commercial purposes, in part or in whole, is not permitted unless authorised by ŠKODA AUTO A. S. ŠKODA AUTO A. S. does not guarantee or accept any liability for the correctness of information in this document. Copyright by ŠKODA AUTO A. S. ©

2.2.3 Replacing Xenon discharge lamp D1S

Removing

- Remove headlight ⇒ [page 99](#) .
- Unscrew screws -arrows- (1 Nm), release springs and remove cover -2-.

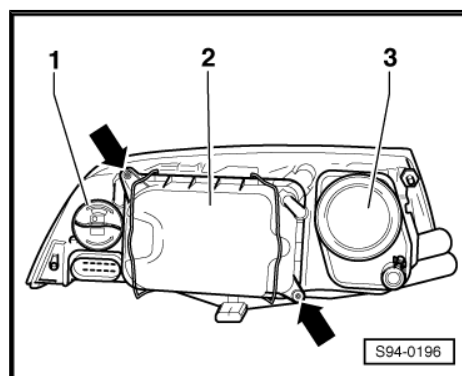

- Disconnect plug connection on the ignition unit of the discharge lamp -1-.
- Release screws -arrows- (1,5 Nm).
- Remove Xenon discharge lamp.

Installing

Installation is carried out in the reverse order. When installing, observe the following:

- Inspecting the headlight beam setting => Maintenance ; Booklet Octavia II .
- Perform basic adjustment of headlight range control=> Vehicle diagnostic tester.

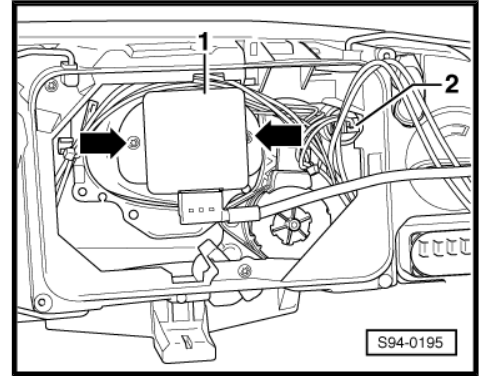

2.2.4 Removing and installing the control unit for a gas discharge lamp



WARNING

Mortal high voltage, risk of injury and risk of pollution.

Observe use and safety instructions for gas discharge lamps => Electrical System – general notes; Rep. gr. 94 .

Removing

- Remove headlight => [page 99](#) .
- Unscrew screws -arrows- (1 Nm), release springs and remove cover -2-.

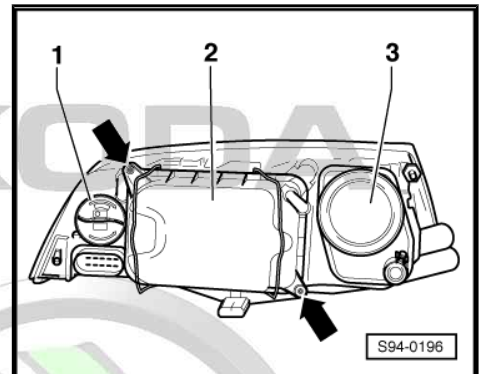

- Release screws -arrows- (0,7 Nm).
- Remove the control unit for gas discharge lamp from the cover.
- Disconnect the plug connections from the control unit for gas discharge lamp.

Installing

The installation occurs in reverse order.

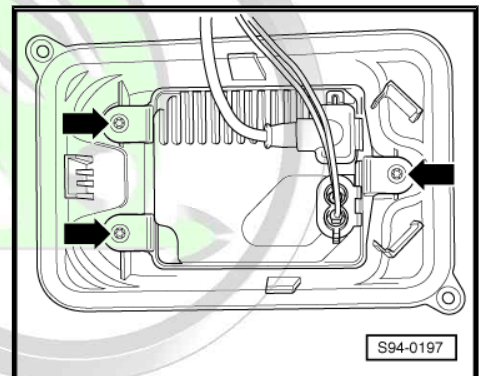

2.2.5 Convert headlight for left-hand / right-hand traffic

The headlight inner aperture should be switched over when driving in countries which drive on the left or the right thereby preventing blinding of the drivers travelling in the opposite direction.

Reproduction for private or commercial purposes, in part or in whole, is not permitted unless authorised by ŠKODA AUTO A. S. ŠKODA AUTO A. S. does not guarantee or accept any liability with respect to the correctness of information in this document. Copyright by ŠKODA AUTO A. S. ©

Work procedure

- Remove headlight => [page 97](#) .
- Unscrew screws -arrows- (1 Nm), release springs and remove cover -2-.



Note

It is recommended to remove the gas discharge lamp => [page 110](#) and to check the correct fitting of the trim after switch-over and by looking into the reflector. The upper edge of the trim -2- is flush with the upper edge of the cover -3- (see figures) after the switch-over.

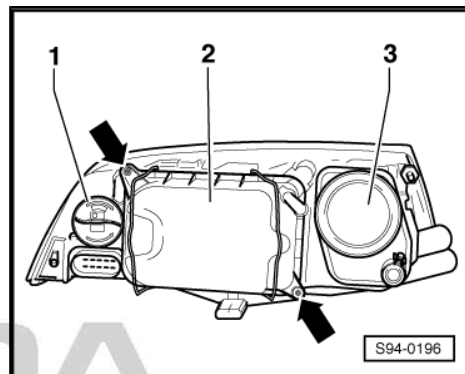

Left-hand drive in left-hand traffic

The headlight on the left

- Insert a small cross-head screwdriver through the opening -arrow- into the hole in the lever -1- slightly press it forward and switch over from the basic position -B- into the position -A-.
- 2- Trim
- 3- Cover

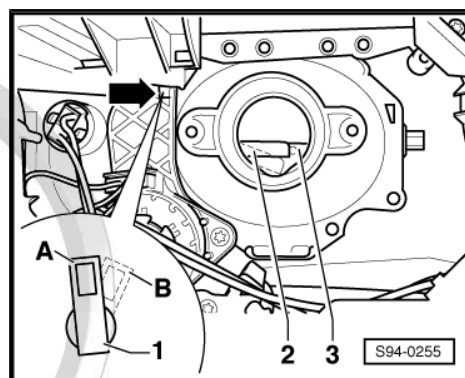

The headlight on the right

- Insert a small cross-head screwdriver into the hole in the lever -1- slightly press it forward and switch over from the basic position -B- into the position -A-.
- 2- Trim
- 3- Cover

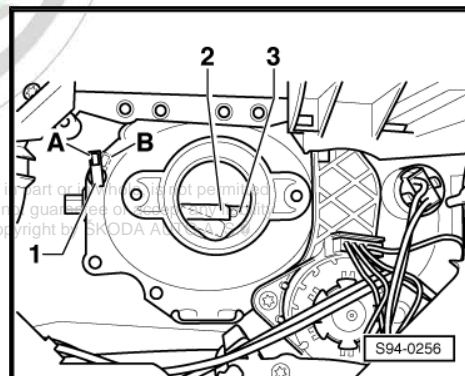

Right-hand drive in right-hand traffic

The headlight on the left

- Insert a small cross-head screwdriver into the hole in the lever -1- slightly press it forward and switch over from the basic position -A- into the position -B-.
- 2- Trim
- 3- Cover

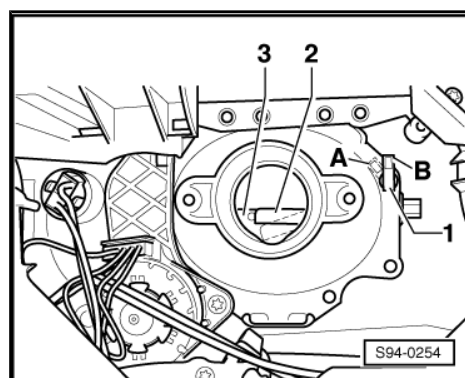

- Insert a small cross-head screwdriver through the opening -arrow- into the hole in the lever -1- slightly press it forward and switch over from the basic position -A- into the position -B-.
- 2- Trim
- 3- Cover

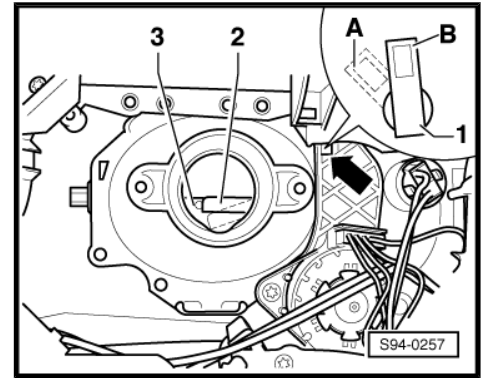

2.3 Headlights with Xenon discharge lamps and cornering light - vehicles as of MY 09

- ⇒ [“2.3.1 General description”, page 113](#)
- ⇒ [“2.3.2 Summary of components of headlight”, page 114](#)
- ⇒ [“2.3.3 Replacing Xenon discharge lamp D1S”, page 115](#)
- ⇒ [“2.3.4 Replacing bulb for main beam H1”, page 115](#)
- ⇒ [“2.3.5 Replacing bulb for turn signal light PY21W”, page 116](#)
- ⇒ [“2.3.6 Replacing bulb W5W/W5W BL for the parking light”, page 116](#)
- ⇒ [“2.3.7 Removing and installing control unit for gas discharge lamp J344 right or J343 left”, page 117](#)
- ⇒ [“2.3.8 Remove and install performance module for the headlight J668 right or J667 left.”, page 117](#)
- ⇒ [“2.3.9 Convert headlight for left-hand / right-hand traffic”, page 118](#)

2.3.1 General description

The headlights with Xenon discharge lamps variable have an AFS system (Adaptive Frontlighting System) and an automatic headlight range control.

The cornering light and headlight range control unit - J745- evaluates the following entry information:

- ◆ Steering wheel angle and direction
- ◆ Vehicle speed
- ◆ Reversing lights on
- ◆ Switching on the headlight (low beam light or main beam light)
- ◆ Signals of vehicle level sensors on front and rear axle
- ◆ individual wheel speeds
- ◆ Position of the light switch

On the basis of this information, it controls the rotary and inclination movement of the headlights.

- ⇒ [“2.4 Removing and installing control unit for headlight range control J431 or cornering light and headlight range control unit J745”, page 118](#)
- -G76-
⇒ [“2.5 Removing and installing vehicle level sensor G78 front left or G76 rear left”, page 118](#)

Protected by copyright. Copying for private or commercial purposes, in part or in whole, is not permitted unless authorised by ŠKODA AUTO A. S. ŠKODA AUTO A. S. does not guarantee or accept any liability with respect to the correctness of information in this document. Copyright by ŠKODA AUTO A. S. ©

- ⇒ ["7.1.4 Removing and installing steering angle sender G85"](#), [page 136](#)

2.3.2 Summary of components of headlight

1 - Headlight housing

- ❑ Removing and installing is the same as for the halogen headlight ⇒ [page 99](#)
- ❑ Adjust ⇒ [page 99](#)

2 - Light bulb for the turn signal light

- ❑ Light bulb PY21W, 12 V, 21 W
- ❑ Replace ⇒ [page 116](#)

3 - Lamp socket for the turn signal light

4 - Control unit for gas discharge lamp - J344- right or -J343- left

- ❑ Removing and installing ⇒ [page 117](#)

5 - Cover

6 - Discharge lamp with integrated high voltage ignition unit

- ❑ Type D1S, 35 W
- ❑ Replace ⇒ [page 115](#)

7 - Light bulb for the parking light

- ❑ Light bulb W5W / W5W BLUE, 12 V, 5 W
- ❑ Replace ⇒ [page 116](#)
- ❑ Vehicles "RS" as of CW 22.09 - light bulb not operational, parking light in individual multifunctional lamp with LED diodes via fog light see ⇒ [page 130](#)

8 - Socket for gas discharge lamp

9 - Performance module for the headlight - J668- right or -J667- left

- ❑ Removing and installing ⇒ [page 117](#)

10 - Cover

11 - Light bulb for main beam

- ❑ Light bulb H1, 12 V, 55 W
- ❑ Replace ⇒ [page 115](#)

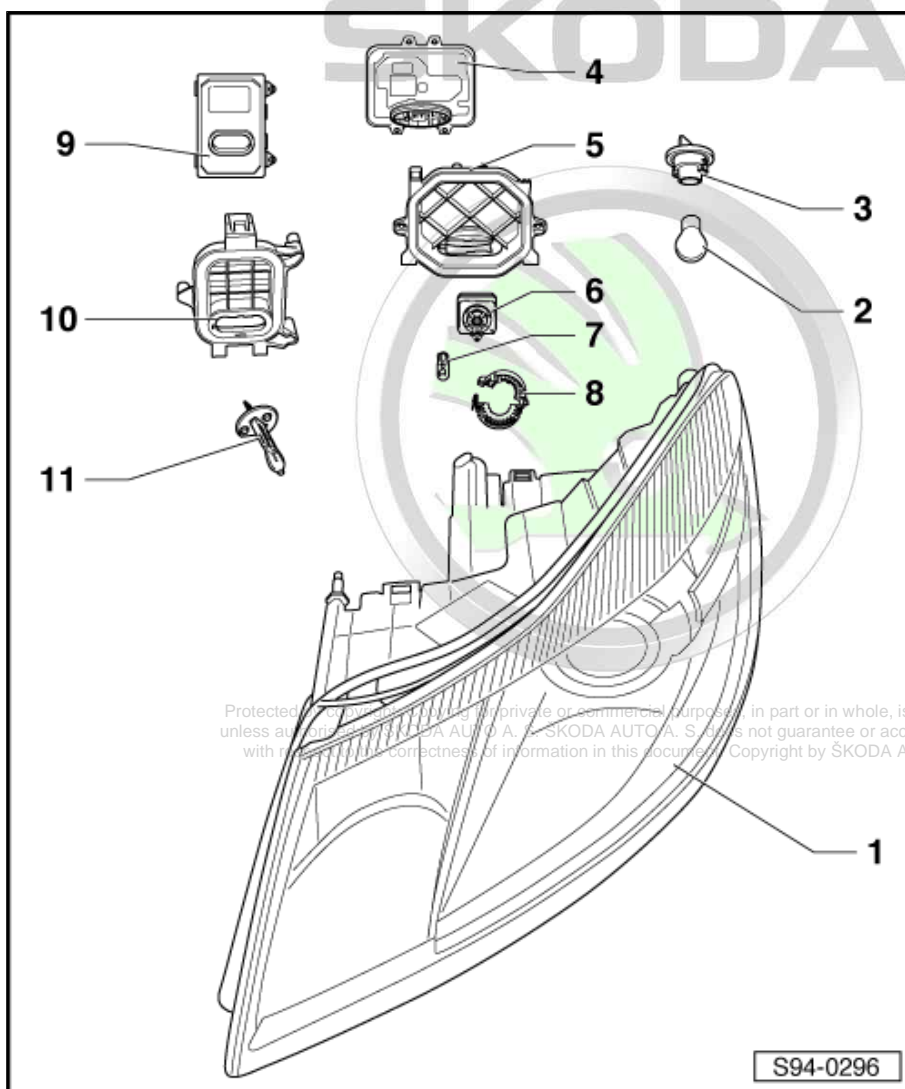

Protected by copyright. Any reproduction for private or commercial purposes, in part or in whole, is not permitted unless authorized by SKODA AUTO A. S. SKODA AUTO A. S. does not guarantee or accept any liability with respect to the correctness of information in this document. Copyright by SKODA AUTO A. S. ©

S94-0296

2.3.3 Replacing Xenon discharge lamp D1S



WARNING

Mortal high voltage, risk of injury and risk of pollution.

*Observe use and safety instructions for gas discharge lamps
⇒ Electrical System – general notes; Rep. gr. 94 .*

Removing

- Remove headlight ⇒ [page 99](#) .
- Press the catches -arrows B- and remove the headlight cover -3- with the control unit for gas discharge lamp -2- while taking into account the connected cable lengths and fold down.

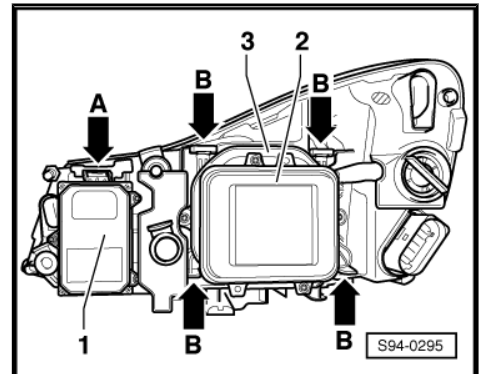

- To unlock, press the peg -2- on the plug -1- and disconnect the plug towards the bottom.
- Turn gas discharge lamp with ignition unit -3- by approx. 45° -arrow- and remove from the headlight housing.

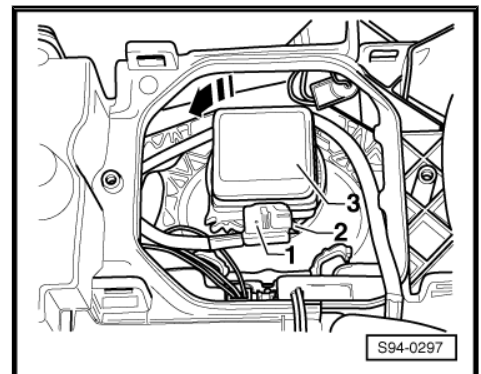

Protected by copyright. Copying for private or commercial purposes, in part or in whole, is not permitted unless authorised by ŠKODA AUTO A. S. ŠKODA AUTO A. S. does not guarantee or accept any liability with respect to the correctness of information in this document. Copyright by ŠKODA AUTO A. S. ©

- Press the catch -arrow-, open the socket -1- and take out the gas discharge lamp.

Installing

Installation is carried out in the reverse order. When installing, observe the following:

- Inspecting the headlight beam setting ⇒ Maintenance ; Booklet Octavia II .
- Perform basic adjustment of headlight range control ⇒ Vehicle diagnostic tester.

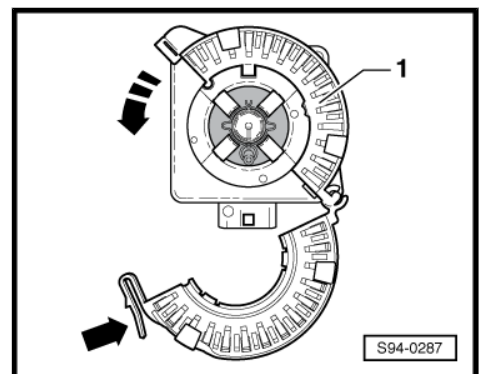

2.3.4 Replacing bulb for main beam H1

- Remove headlight ⇒ [page 99](#) .

- Press the catch -arrow A- and fold down the cover with the performance module for the headlight -1- while taking into account the connected cable lengths.

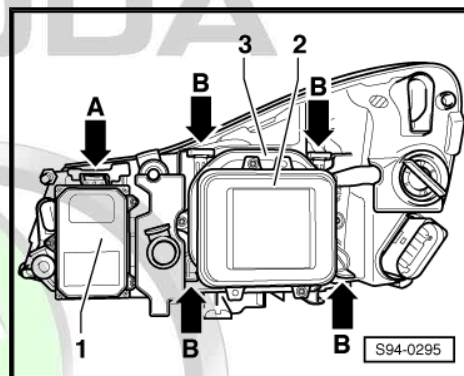

- Disconnect plug connection -1-.
- Release the wire spring clamp -2- and remove the light bulb.
- The installation occurs in reverse order.

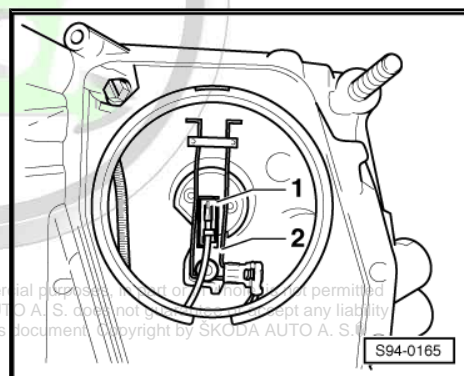

Protected by copyright. Copying for private or commercial purposes without the express written permission of ŠKODA AUTO A. S. ŠKODA AUTO A. S. does not accept any liability with respect to the correctness of information in this document. Copyright by ŠKODA AUTO A. S.

2.3.5 Replacing bulb for turn signal light PY21W

- Remove headlight => [page 99](#) .
- Remove bulb socket -1- by turning in the direction of the arrow "OPEN".
- Remove the bulb from the socket.
- The installation occurs in reverse order.

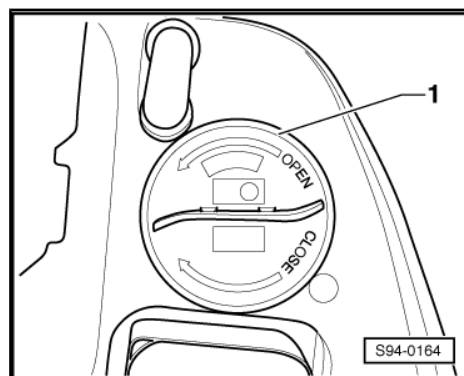

2.3.6 Replacing bulb W5W/W5W BL for the parking light

- Remove headlight => [page 99](#) .
- Press the catches -arrows B- and remove the headlight cover -3- with the control unit for gas discharge lamp -2- while taking into account the connected cable lengths and fold down.

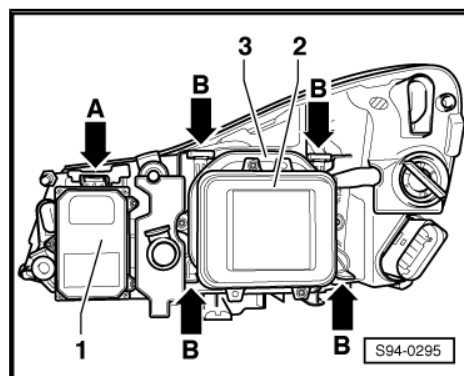

- Grip the extended bulb socket -1- with pliers and remove it while taking into account the connected cable lengths -arrow-.

ŠKODA

- Push the light bulb -2- out of the socket -arrow- and replace.
- After replacing the bulb, press socket and bulb fully into the headlight.
- Further installation occurs in reverse order.

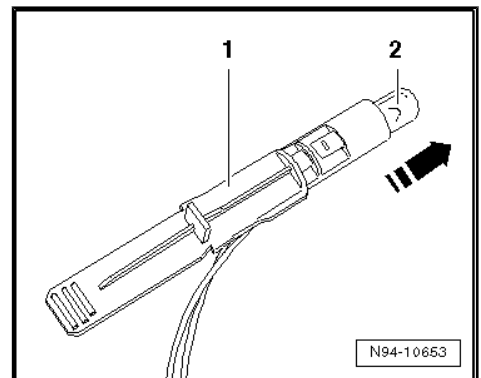
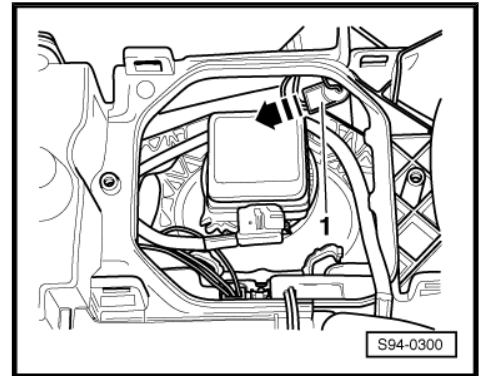

2.3.7 Removing and installing control unit for gas discharge lamp - J344- right or - J343- left

- Remove headlight => [page 99](#).
- Release screws -3- (1.4 Nm) and remove the control unit -2-.
- The installation occurs in reverse order.

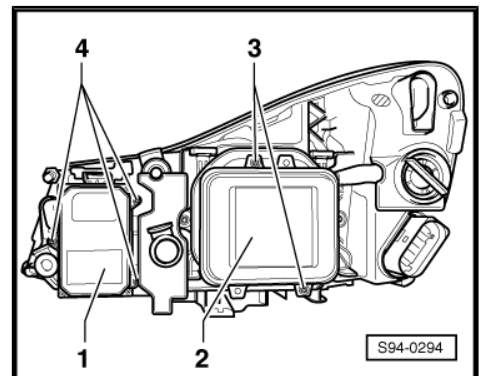

2.3.8 Remove and install performance module for the headlight - J668- right or - J667- left.

- Remove headlight => [page 99](#) .

- Release screws -4- (1.4 Nm) and remove the control unit -1-.
- The installation occurs in reverse order.

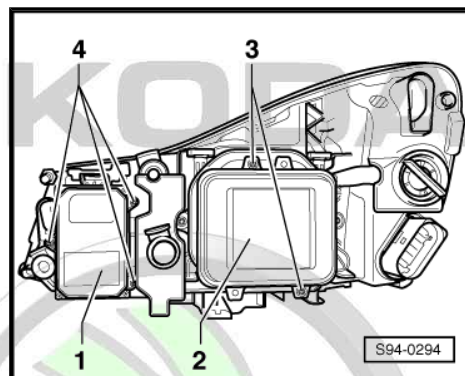

2.3.9 Convert headlight for left-hand / right-hand traffic

The position of the ray of light should be adjusted when driving in countries which drive on the right or the left thereby preventing blinding of the drivers travelling in the opposite direction.

On vehicles which have the Maxi DOT display in the dash panel insert, the position of the ray of light in the menu "Maxi DOT" function "light and sight - tourist light - right-hand drive or left-hand drive" can be adjusted see => Owner's manual Octavia II .

If the dash panel insert is not equipped with the Maxi DOT display, the position of the ray of light must be adjusted with => Vehicle diagnostic tester.

Copyright. Copying for private or commercial purposes, in part or in whole, is not permitted unless authorised by ŠKODA AUTO A. S. ŠKODA AUTO A. S. does not guarantee or accept any liability with respect to the correctness of information in this document. Copyright by ŠKODA AUTO A. S. ©

2.4 Removing and installing control unit for headlight range control - J431- or cornering light and headlight range control unit - J745-

Removing

- Remove AC actuator => Heating, Air Conditioning; Rep. gr. 87 .
- Removing ashtray => Body Work; Rep. gr. 68 .
- Disconnect the plug from the control unit.
- Release screws - 2 - (1,5 Nm).
- Remove control unit -1-.

Installing

Installation is carried out in the reverse order. When installing, observe the following:

If the control unit was replaced:

- Code the control unit and undertake the basic setting for beam range regulation => Vehicle diagnostic tester.

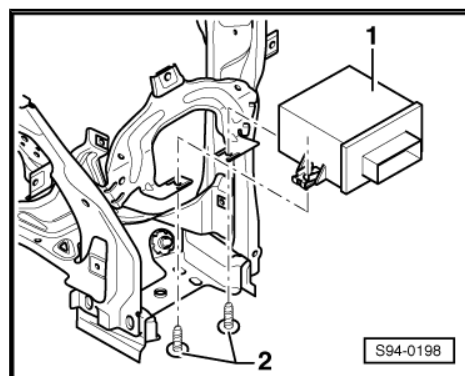

2.5 Removing and installing vehicle level sensor - G78- front left or -G76- rear left

The vehicle level senders are an integral part of the headlight range.

The assembly work is described in the Workshop Manual => Chassis .

- ◆ Install front left vehicle level sensor - G78- ⇒ Chassis; Rep. gr. 40
- ◆ Install rear left vehicle level sensor - G76- ⇒ Chassis; Rep. gr. 42

2.6 Contact assignment of plug connection for control unit for headlight range control - J431- or cornering light and headlight range control unit - J745-

You can find the exact contact assignment in the ⇒ Current flow diagrams, Electrical fault finding and Fitting locations.

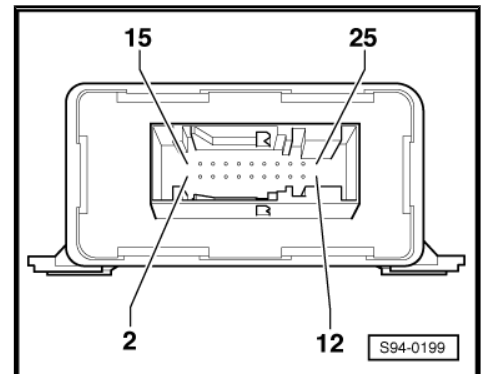

ŠKODA



Protected by copyright. Copying for private or commercial purposes, in part or in whole, is not permitted unless authorised by ŠKODA AUTO A. S. ŠKODA AUTO A. S. does not guarantee or accept any liability with respect to the correctness of information in this document. Copyright by ŠKODA AUTO A. S.®

3 Side turn signal lights

The side turn signal lights are component parts of the exterior mirror holder.

⇒ [“3.1 Removing and installing side turn signal lights - vehicles up to MY 08”, page 120](#)

⇒ [“3.2 Removing and installing side turn signal lights - vehicles as of MY 09”, page 120](#)

3.1 Removing and installing side turn signal lights - vehicles up to MY 08

Removing

- Switch off the ignition and all electrical consumers!
- Remove the mirror housing ⇒ Body Work; Rep. gr. 66 .
- Disconnect electrical plug connection -1-.



Note

The exterior mirror in the illustration is removed for purposes of clear presentation.

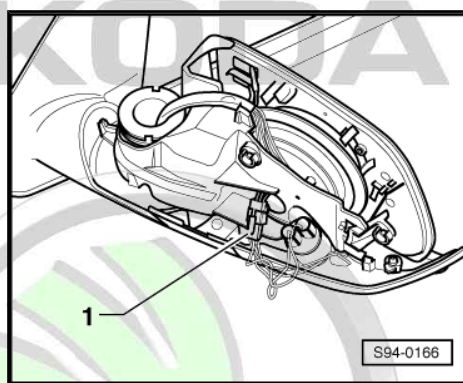

- Release screws -arrows- (1 Nm).
- Remove the mirror holder -1- with side turn signal lights.

Installing

The installation occurs in reverse order.

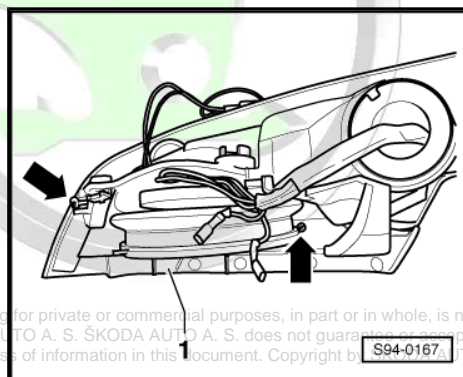

Protected by copyright. Copying for private or commercial purposes, in part or in whole, is not permitted unless authorised by ŠKODA AUTO A. S. ŠKODA AUTO A. S. does not guarantee or accept any liability with respect to the correctness of information in this document. Copyright by ŠKODA AUTO A. S.

3.2 Removing and installing side turn signal lights - vehicles as of MY 09

Removing

- Switch off the ignition and all electrical consumers!
- Remove mirror glass ⇒ Body Work; Rep. gr. 66 .

- Release screws -1- and -3- (0.7 Nm).
- Slacken the upper exterior mirror cover -2- from the catches -arrows- and remove the cover towards the top -movement arrows- from out of the mirror housing.

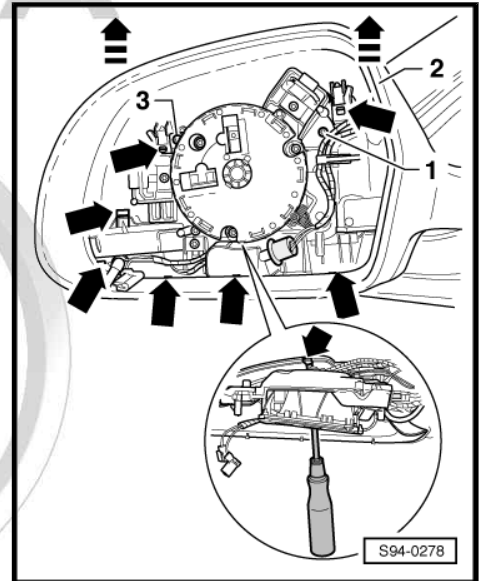

- Remove the socket with the light bulb -2- from the door entry lighting.
- Release screws -arrows- (0.8 Nm) and unhook the lower mirror housing cover -1- to the bottom.

Protected by copyright. Copying for private or commercial purposes, in part or in whole, is not permitted unless authorised by ŠKODA AUTO A. S. ŠKODA AUTO A. S. does not guarantee or accept any liability.

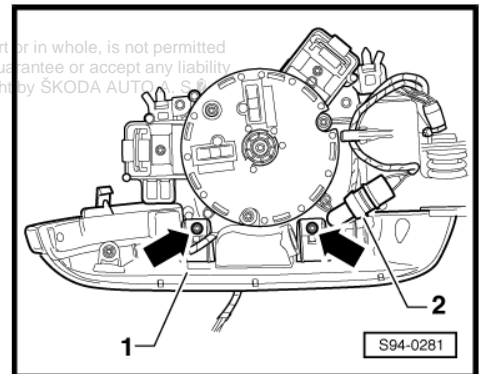

- Screw out screws -4- (0.5 Nm) and slacken the side turn signal -5- out of the lower cover.
- Disconnect plug connection -1-.

Installing

Installation is carried out in the reverse order. When installing, observe the following:

- Perform a functional test (illumination, mirror adjustment).

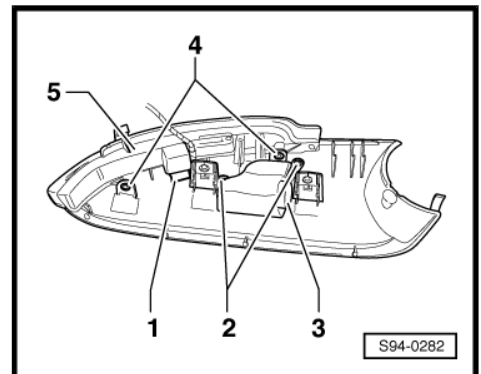

4 Tail lights

⇒ "4.1 Octavia", page 122

⇒ "4.2 Octavia Combi", page 123

4.1 Octavia

⇒ "4.1.1 Summary of components", page 122

⇒ "4.1.2 Removing and installing lamp holder and bulbs", page 122

⇒ "4.1.3 Removing and installing tail light", page 122

4.1.1 Summary of components

- 1 - Fixing nuts, 3 Nm
- 2 - Body
- 3 - Twin filament light bulb for the brake and parking light (P21/4W, 12 V, 21/4 W)
- 4 - Light bulb for the turn signal light (PY21W, 12 V, 21 W)
- 5 - Lamp holder; removing and installing ⇒ page 122
- 6 - Tail light housing
- 7 - Twin filament light bulb for the rear fog light and parking light (P21/4W, 12 V, 21/4 W)
- 8 - Light bulb for the reversing light (P21W, 12 V, 21 W)
- 9 - Light bulbs for the parking light (W3W, 12V, 3 W)

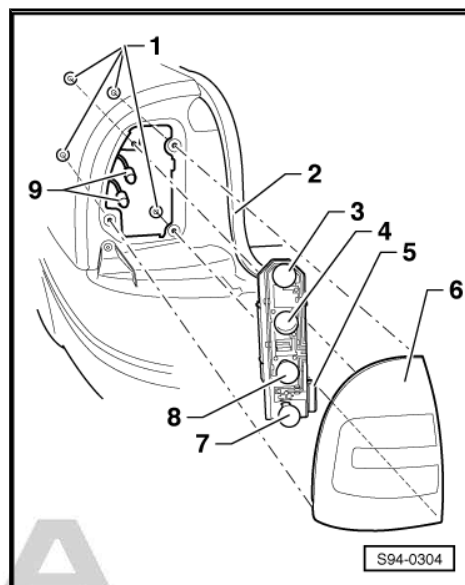

4.1.2 Removing and installing lamp holder and bulbs

Removing

- Switch off the ignition and all electrical consumers!
- Swing the cover of the tail light in the luggage compartment to one side and disconnect the plug connector -2-.
- Press together locking arms -arrows- and remove bulb holder -1-.
- Remove the bulbs from the lamp holder.

Installing

The installation occurs in reverse order.

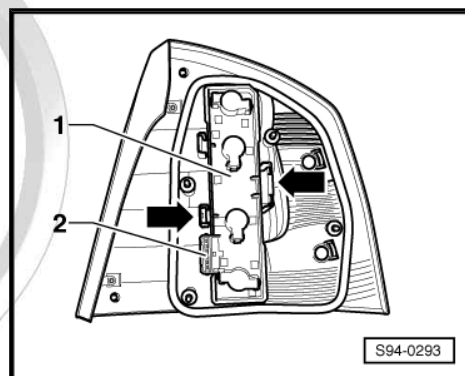

4.1.3 Removing and installing tail light

Removing

- Switch off the ignition and all electrical consumers!

SKODA is not responsible for any errors or omissions, in part or in whole, is not permitted unless authorised by ŠKODA AUTO A. S. ŠKODA AUTO A. S. does not guarantee or accept any liability with respect to the correctness of information in this document. Copyright by ŠKODA AUTO A. S. ©

- Swing the cover in front of the tail light in the luggage compartment to one side and disconnect the plug connector -1-.
- Unscrew the fixing nuts -arrows- (3 Nm) and take the tail light out to the rear.

Installing

Installation is carried out in the reverse order. When installing, observe the following:

- Before tightening the fixing nuts, align the tail light to the contours of the vehicle body (uniform gap size all round).

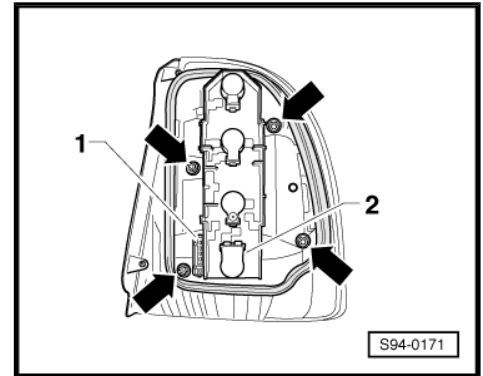

4.2 Octavia Combi

⇒ [“4.2.1 Summary of components”, page 123](#)

⇒ [“4.2.2 Removing and installing lamp holder and bulbs”, page 123](#)

⇒ [“4.2.3 Removing and installing tail light”, page 124](#)

4.2.1 Summary of components

- 1 - Tail light housing
- 2 - Light bulb for the turn signal light (PY21W, 12 V, 21 W)
- 3 - Light bulb for the brake light and parking light (P21W, 12 V, 21 W)
- 4 - Light bulbs for the parking light (W3W, 12 V, 3 W)
- 5 - Fixing nuts, 3 Nm
- 6 - Plug connection for tail light
- 7 - Light bulb for the rear fog light and parking light (P21W, 12 V, 21 W)
- 8 - Light bulb for the reversing light (P21W, 12 V, 21 W)

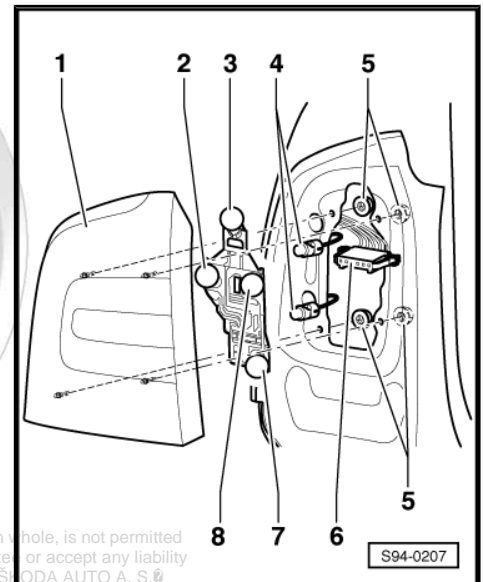

Protected by copyright. Copying for private or commercial purposes, in part or in whole, is not permitted unless authorised by ŠKODA AUTO A. S. ŠKODA AUTO A. S. does not guarantee or accept any liability with respect to the correctness of information in this document. Copyright by ŠKODA AUTO A. S. ©

4.2.2 Removing and installing lamp holder and bulbs

Removing

- Switch off the ignition and all electrical consumers!

- Swing the cover of the tail light in the luggage compartment to one side and disconnect the plug connector -1-.
- Press locking arms upwards and remove the lamp holder -arrow-.
- Remove the bulbs from the lamp holder.

Installing

The installation occurs in reverse order.



4.2.3 Removing and installing tail light

Removing

Protected by copyright. Copying for private or commercial purposes, in part or in whole, is not permitted unless authorised by ŠKODA AUTO A. S. ŠKODA AUTO A. S. does not guarantee or accept any liability information in this document. Copyright by ŠKODA AUTO A. S. ©

- Switch off the ignition and all electrical consumers!
- Swing the cover in front of the tail light in the luggage compartment to one side and disconnect the plug connector -1-.
- Unscrew the fixing nuts -A- (3 Nm) and take the tail light out to the rear.

Installing

Installation is carried out in the reverse order. When installing, observe the following:

- Before tightening the fixing nuts, align the tail light to the contours of the vehicle body (uniform gap size all round).

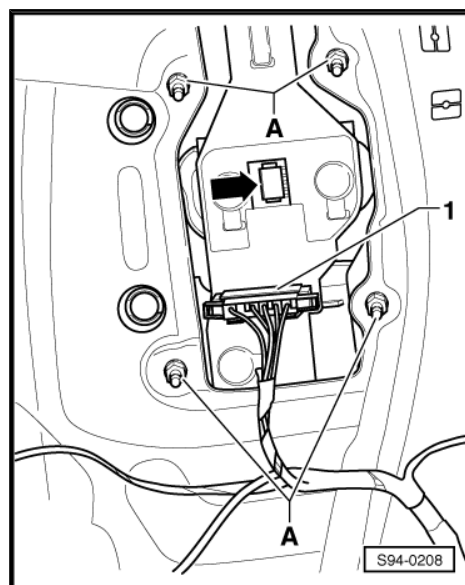

5 Fog lights, fog lights with the “Corner” function and daylight driving light

⇒ [“5.1 General description, fault recognition and fault display”](#), page 125

⇒ [“5.2 Removing and installing fog light/daylight driving light”](#), page 126

⇒ [“5.3 Lamps for daylight driving light - Octavia Scout \(vehicles as of CW 22.10\)”](#), page 128

⇒ [“5.4 Replacing the lamp for the fog light and for the fog light with the Corner function”](#), page 128

⇒ [“5.5 Removing and installing light bulb for daylight driving light \(except Octavia RS and Scout\) - vehicles as of MY 09”](#), page 129

⇒ [“5.6 Daylight driving light and parking light Octavia RS - as of CW 22/09”](#), page 130

⇒ [“5.7 Adjusting fog lights, fog lights with the Corner function”](#), page 130

5.1 General description, fault recognition and fault display

General description

As of CW 22/07 (except for vehicles Octavia RS and Scout) fog lights with the “Corner” function are mounted.

As of CW 22/09 fog lights with the “Corner” function are also mounted in vehicles RS and Scout.

As of CW 22/09 an individual lamp with LED diodes for daylight driving light and parking light is mounted in Octavia RS vehicles.

On Octavia Scout vehicles as of CW 22/10, you can choose to install fog lights or lamps with LED diodes for daylight driving light.

The fog lights with the “Corner” function ensure that the surrounding area of the vehicle is better illuminated when turning, parking etc.

The fog lights with the static cornering light function are controlled together with additional functions via the onboard control unit - J519- .

On vehicles as of MY 09, a lamp for daylight driving light -1- is integrated in the headlight housing (except for Octavia RS, Scout and Tour).

Further information and description of function ⇒ Owner's manual Octavia II .

Fault recognition and fault display

The vehicle voltage control unit - J 519- , which regulates the functions of the fog lights with the Corner function as well as the daylight driving light, is equipped with self-diagnosis which facilitates the fault finding.

Use the ⇒ Vehicle diagnostic tester in the function “Targeted fault finding” and “Final control diagnosis” for checking and fault finding of the fog lights with the “Corner” function and daylight driving light.

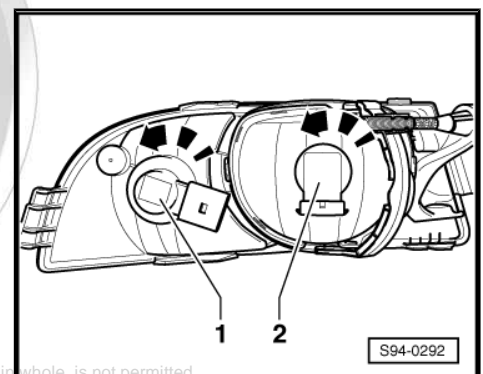

5.2 Removing and installing fog light/day-light driving light

⇒ [“5.2.1 Installing and removing - Octavia Tour and vehicles up to MY 08 \(does not apply for Octavia RS and Scout\)”](#), page 126

⇒ [“5.2.2 Installing and removing - vehicles as of MY 09 \(does not apply for Octavia RS, Scout and Tour\)”](#), page 126

⇒ [“5.2.3 Removing and installing - Octavia RS and Scout - vehicles up to CW 21.09”](#), page 127

⇒ [“5.2.4 Removing and installing - Octavia RS and Scout - vehicles as of CW 22/09”](#), page 127

5.2.1 Installing and removing - Octavia Tour and vehicles up to MY 08 (does not apply for Octavia RS and Scout)

Removing

- Switch off the ignition and all electrical consumers!
- Remove the cover next to the fog light ⇒ Body Work; Rep. gr. 63 .
- Release screws -arrows- (1,5 Nm).
- Remove the fog light.
- Disconnect plug.

Installing

Installation is carried out in the reverse order. When installing, observe the following:

- Perform a functional check or adjust ⇒ Maintenance ; Booklet Octavia II .

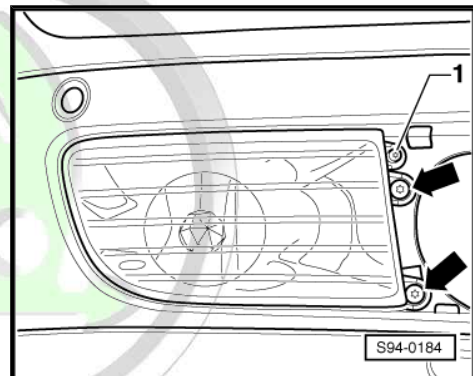

5.2.2 Installing and removing - vehicles as of MY 09 (does not apply for Octavia RS, Scout and Tour)

Protected by copyright. Copying for private or commercial purposes, in part or in whole, is not permitted unless authorised by ŠKODA AUTO A. S. ŠKODA AUTO A. S. does not guarantee or accept any liability with respect to the correctness of information in this document. Copyright by ŠKODA AUTO A. S. ©

Removing

- Switch off the ignition and all electrical consumers!
- Unclip cover next to the fog light from the bumper -arrows-.

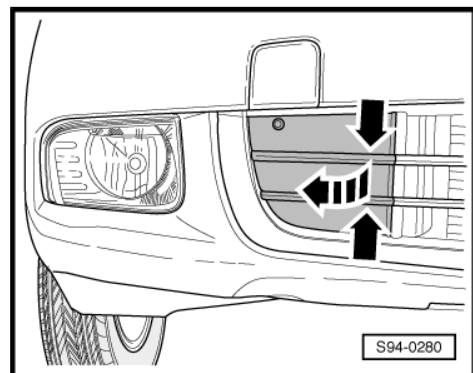

- Press the catch -arrow- from the inside, swivel out the fog light and remove it.
- Disconnect plug.

Installing

- Mount plug.
- Insert the headlight in the assembly opening and press it in until it clicks into place -arrow-.
- Install shock absorber cover.
- Perform a functional check or adjust ⇒ Maintenance ; Booklet Octavia II .

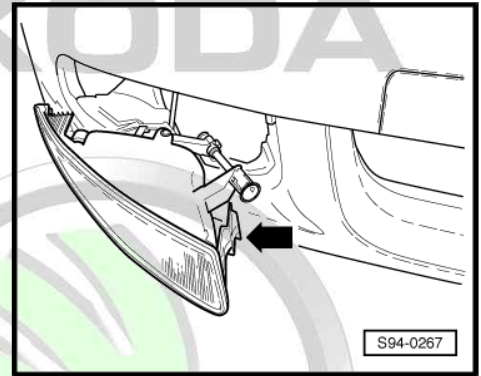

5.2.3 Removing and installing - Octavia RS and Scout - vehicles up to CW 21.09

Removing

- Switch off the ignition and all electrical consumers!
- Remove front bumper ⇒ Body Work; Rep. gr. 63 .
- Disconnect plug.
- Screw out the screw -arrows- (1.5 Nm) and remove the fog lights.

Installing

Installation is carried out in the reverse order. When installing, observe the following:

- Perform a functional check or adjust ⇒ Maintenance ; Booklet Octavia II .

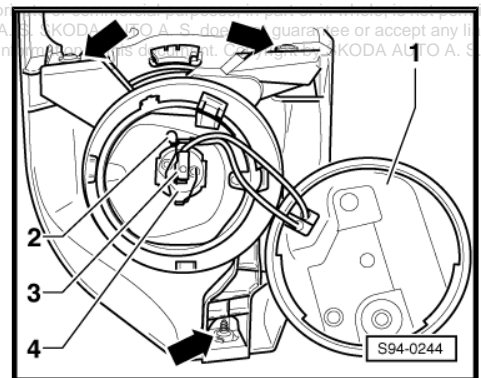

5.2.4 Removing and installing - Octavia RS and Scout - vehicles as of CW 22/09

Removing

- Switch off the ignition and all electrical consumers!
- Octavia RS - insert a finger in the opening of the cover for fog light and unclip from the bumper.
- Octavia Scout - insert a wire hook from the repair kit in the opening above the fog light -arrow- and remove the cover -1-.
- Unscrew the screws -arrows- (1.5 Nm) and remove fog light (Octavia RS) or daylight driving light/fog light (Octavia Scout -1-).

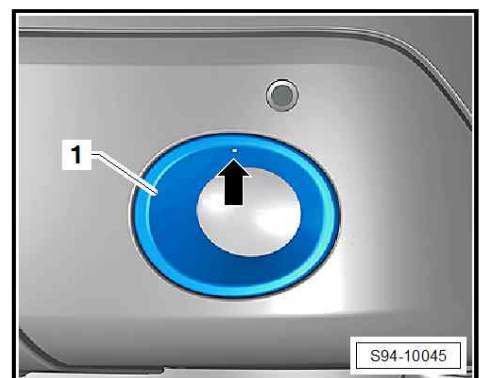



Octavia RS

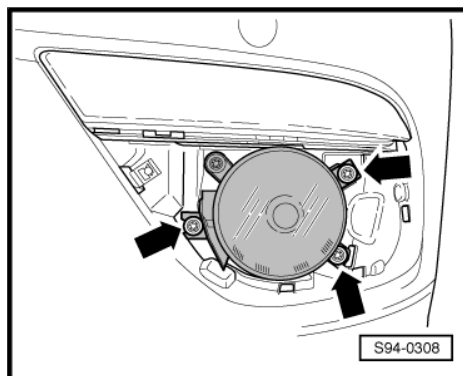

Octavia Scout

- Disconnect plug.

Installing

Installation is carried out in the reverse order. When installing, observe the following:

- Perform a functional check or adjust the lamp ⇒ Maintenance ; Booklet Octavia II .

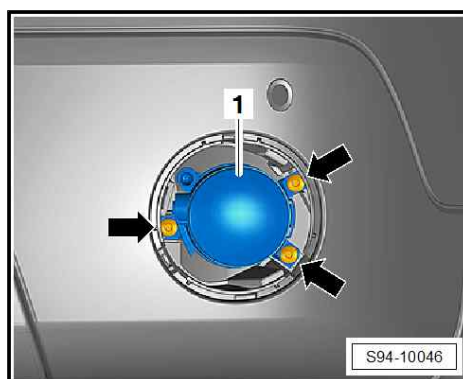

5.3 Lamps for daylight driving light - Octavia Scout (vehicles as of CW 22.10)

On Octavia Scout vehicles as of CW 22/10, two equipment variants are possible:

- ◆ Fog lights with the “Corner” function (HB4 bulb).
- ◆ Lights with LED diodes for daylight driving light.

The installation and removal of the lights with LED diodes is carried out as for fog lights ⇒ [page 127](#) .

Lights with LED diodes are not configured.

The functions of the light are regulated via the vehicle voltage control unit - J519- , it is equipped with self-diagnosis, which facilitates the fault finding.

In the event of a fault, the lamp must be replaced completely.

5.4 Replacing the lamp for the fog light and for the fog light with the “Corner” function



WARNING

H1, H8 and HB4 bulbs are pressurized and can burst when changing the bulb. It is recommended to wear gloves and safety glasses when changing bulbs.

SKODA AUTO A. S. SKODA AUTO A. S. does not guarantee or accept any liability in part or in whole, is not permitted with respect to the correctness of information in this document. Copyright by ŠKODA AUTO A. S. ©

Removing

All vehicles except Octavia RS and Scout

- Remove headlight (depending on the model year and the type) ⇒ [page 126](#) .

- Turn bulb socket -2- 45° in the -direction of the arrow-.
- Replace bulb "H8" 12 V, 35 W.

Octavia RS and Scout - up to CW 21/09

- Switch off the ignition and all electrical consumers!
- Remove the front part of the front wheelhouse liner on the side of the bulb to be removed ⇒ Body Work; Rep. gr. 66 .

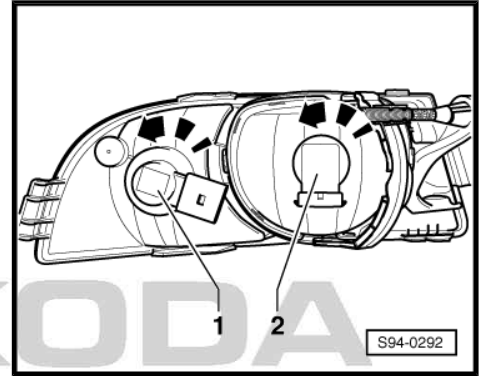

- Disconnect the plug connection, release the cover -1- by turning to the left and swivel out.
- Disconnect plug connection -3- and release the wire spring clamp -2-.
- Replace bulb -4- "H1" 12 V, 55 W.

Octavia RS and Scout - as of CW 22/09

- Remove fog light ⇒ [page 127](#) .

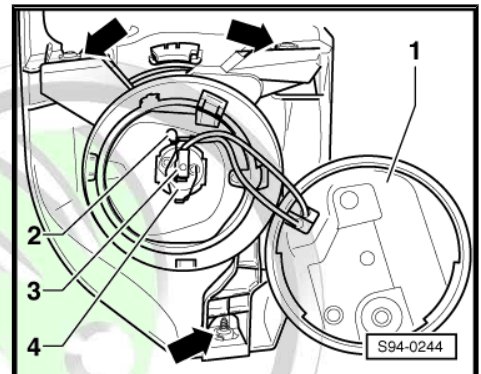

- Disconnect plug connection, turn bulb socket -arrow- and take out light bulb -1-.
- Replace faulty bulb "HB4" 12 V, 35 W.

Installing

Installation is carried out in the reverse order. When installing, observe the following:

- Perform a functional check or adjust ⇒ Maintenance ; Booklet Octavia II .

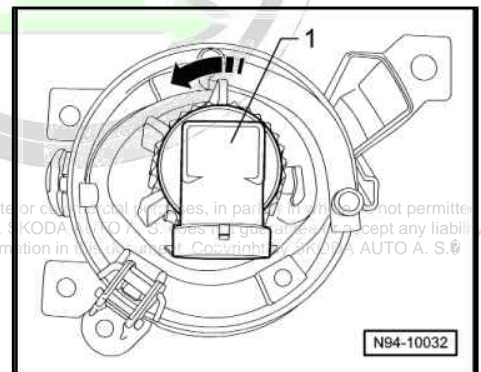

5.5 Removing and installing light bulb for daylight driving light (except Octavia RS and Scout) - vehicles as of MY 09

Removing

- Remove headlight ⇒ [page 126](#) .
- Turn socket with bulb -1- -arrow- and remove.
- Remove light bulb "PY21W" and replace.

Installing

The installation occurs in reverse order.

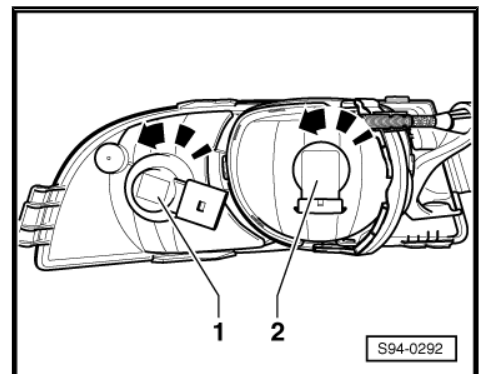

5.6 Daylight driving light and parking light Octavia "RS" - as of CW 22/09

As of CW 22.09, vehicles "RS" have an individual multifunctional lamp with LED diodes for daylight driving light and parking light. The intensity of the LED diodes is reduced for the parking light. The light bulb for the parking light does not operate in the headlight.

The functions of the light are regulated via the vehicle voltage control unit - J519- , it is equipped with self-diagnosis, which facilitates the fault finding.

For checking and fault finding use the ⇒ Vehicle diagnostic tester in the function "Targeted fault finding".

Removing

- Switch off the ignition and all electrical consumers!
- Remove front bumper ⇒ Body Work; Rep. gr. 63 .
- Screw out the screws -arrows- (1.5 Nm) and remove the light -1-.

Installing

The installation occurs in reverse order.

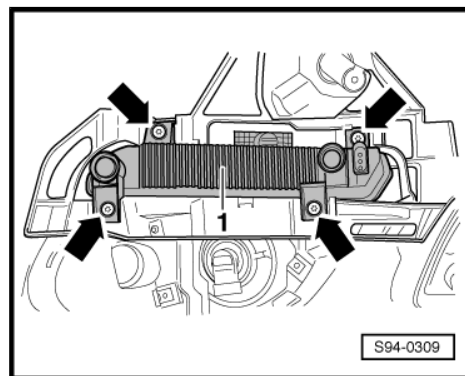

5.7 Adjusting fog lights, fog lights with the "Corner" function

Use a headlight beam setting device for setting the headlight beam. Specified values, setting elements, conditions and measurement ⇒ Maintenance ; Booklet Octavia II .

Protected by copyright. Copying for private or commercial purposes, in part or in whole, is not permitted unless authorised by ŠKODA AUTO A. S. ŠKODA AUTO A. S. does not guarantee or accept any liability with respect to the correctness of information in this document. Copyright by ŠKODA AUTO A. S. ©

6 Additional brake light



Note

The high level brake light is fitted with LEDs which cannot be replaced individually.

⇒ [“6.1 Removing and installing the high level brake light - Octavia”, page 131](#)

⇒ [“6.2 Removing and installing the high level brake light - Octavia Combi”, page 131](#)

6.1 Removing and installing the high level brake light - Octavia

Removing

- Switch off the ignition and all electrical consumers!
- Remove the tailgate trim panel ⇒ Body Work; Rep. gr. 70 .
- Unscrew screws -2- (0.8 Nm).
- Release locking tabs -arrows-.
- Disconnect plug connection -1-.
- Remove high level brake light.

Installing

The installation occurs in reverse order.

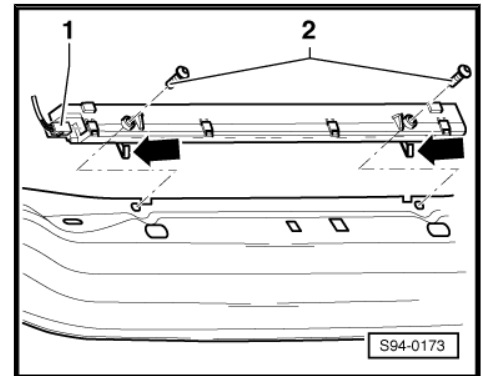

6.2 Removing and installing the high level brake light - Octavia Combi

Removing

- Switch off the ignition and all electrical consumers!
- Remove the tailgate trim panel ⇒ Body Work; Rep. gr. 70 .
- Unscrew the nuts -1-.
- Unlatch locking tab -2-.
- Slightly pull out the high level brake light.
- Detach connector and hose to spray nozzle.

Installing



Note

During installation it is important to keep to the tightening sequence of the fixing nuts!

- Connect connector and hose to spray nozzle.

Tightening torque of fixing nuts is 0.7 Nm.

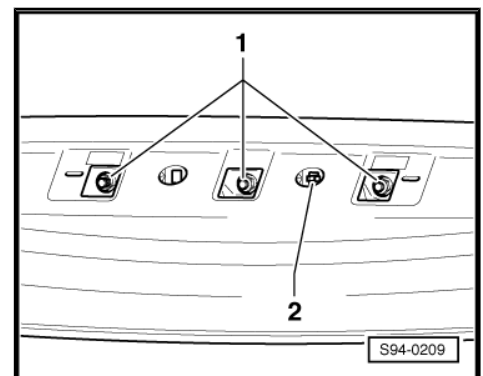



- Insert lamp into the assembly opening and initially tighten the middle nut -1-.
- Next tighten nut -2- (next to the spray nozzle) and finally nut -3-.
- Further installation occurs in reverse order.
- After installing, perform a functional test.

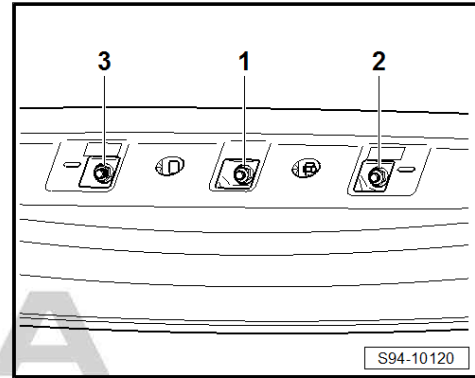

ŠKODA



Protected by copyright. Copying for private or commercial purposes, in part or in whole, is not permitted unless authorised by ŠKODA AUTO A. S. ŠKODA AUTO A. S. does not guarantee or accept any liability with respect to the correctness of information in this document. Copyright by ŠKODA AUTO A. S. ©

7 Steering column switch

Description of the system and the function ⇒ Self-study programme No. 54 ; Skoda Octavia II Electrical Components .

Self-diagnosis and fault indication

The steering column electronics control unit - J527- is equipped with self-diagnosis, which facilitates the fault finding.

For fault finding use the ⇒ Vehicle diagnostic tester in the function "Targeted fault finding".

⇒ ["7.1 Steering column switch- vehicles up to CW 21/10", page 133](#)

⇒ ["7.2 Steering column switch- vehicles as of CW 22/10", page 141](#)

⇒ ["7.3 Setting middle position of the return ring with coil spring", page 144](#)

7.1 Steering column switch- vehicles up to CW 21/10

⇒ ["7.1.1 Summary of components of steering column switch", page 133](#)

⇒ ["7.1.2 Removing and installing steering column electronics control unit J527 ", page 134](#)

⇒ ["7.1.3 Removing and installing return ring with coil spring F350 ", page 135](#)

⇒ ["7.1.4 Removing and installing steering angle sender G85 ", page 136](#)

⇒ ["7.1.5 Removing and installing lever key of switch mounting on the steering column", page 136](#)

⇒ ["7.1.6 Removing and installing switch mounting on the steering column", page 137](#)

⇒ ["7.1.7 Contact assignment on the steering column electronics control unit J527 ", page 139](#)

7.1.1 Summary of components of steering column switch





1 - Left lever key

- ◆ Removing and installing
⇒ [page 136](#)

2 - Switch mounting on the steering column

- ◆ Removing and installing
⇒ [page 137](#)

3 - Right lever key

- ◆ Removing and installing
⇒ [page 136](#)

4 - Fixing screw

5 - Steering column electronics control unit - J527-

- ◆ Removing and installing
⇒ [page 134](#)

6 - Return ring with coil spring - F350-

- ◆ Removing and installing
⇒ [page 135](#)

7 - Steering angle sender - G85-

- ◆ Removing and installing
⇒ [page 136](#)

- ◆ Right-hand drive as of CW 22/08 and left-hand drive as of CW 22/09 - sender integrated in the steering gear

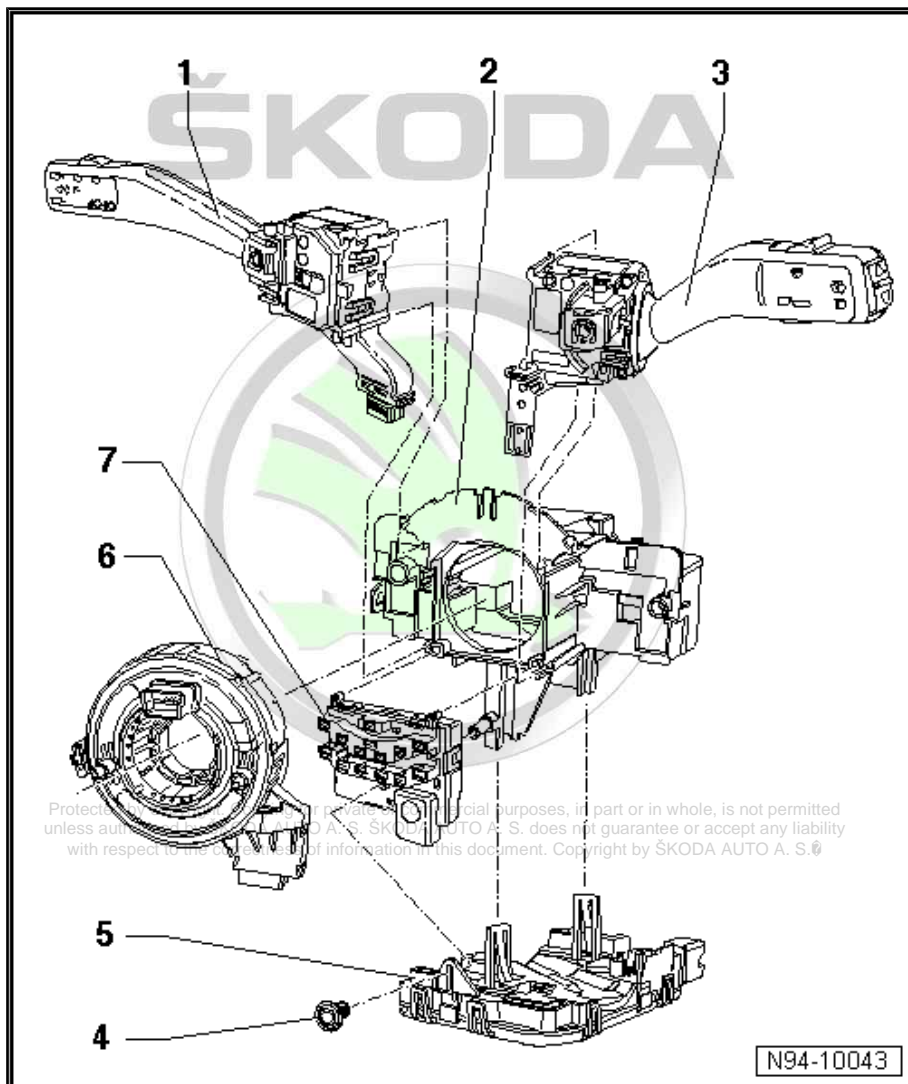

7.1.2 Removing and installing steering column electronics control unit - J527-



Note

The new control unit must be coded after the installation see
⇒ *Vehicle diagnostic tester*.

Special tools and workshop equipment required

- ◆ Drill Ø 2.5 mm

Removing

- Disconnect battery earth strap ⇒ [page 2](#) .
- Remove steering wheel ⇒ *Body Work; Rep. gr. 69* .
- Removing top and bottom steering column trim ⇒ *Body Work; Rep. gr. 70* .

- Release screw -1- (0,4 Nm).
- Insert in the opening -arrow 1- the drill -2- (\varnothing 2.5 mm)
- Unlatch the fuse in -direction of arrow 2- using the drill.

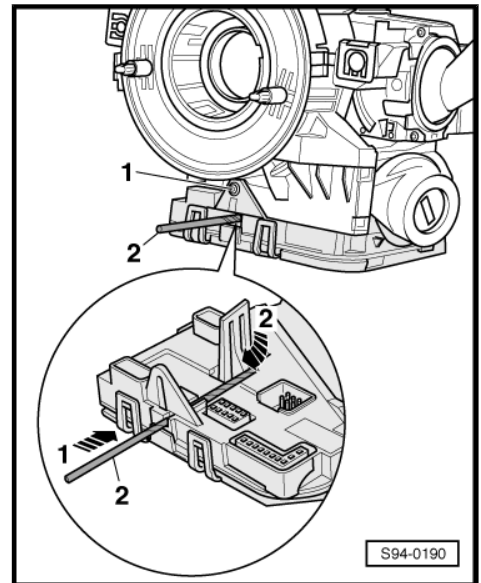

- Press fuse on the connector side with a suitable screwdriver in -direction of arrow-, in order to unlatch it.
- Carefully pull off control unit from the switches straight to the bottom in such a way that it does not tilt.

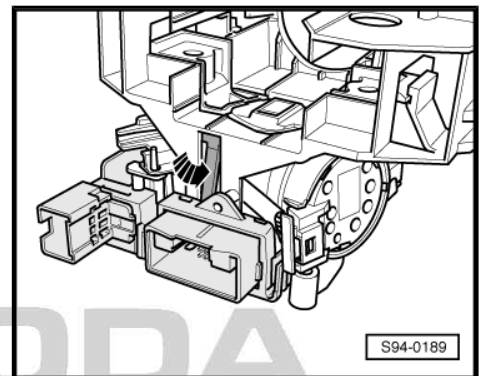

- Release plug connection -1- -arrow A- and disconnect.
- Pull lock -3- out of the plug connection -2-, press fuse -arrow B- and disconnect plug connection.

Installing

Installation is carried out in the reverse order. When installing, observe the following:

- Make sure that all the retaining lugs and plug connections lock in place correctly.
- Follow the work procedure when connecting the battery [=> page 2](#) .

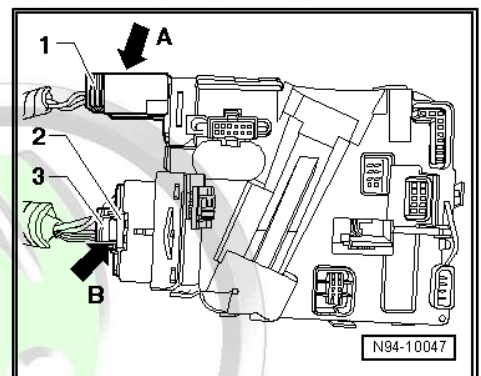

7.1.3 Removing and installing return ring with coil spring - F350-

Removing

- Removing steering column electronics control unit - J527- [=> page 134](#) .

Protected by copyright. Copying for private or commercial purposes, in part or in whole, is not permitted unless authorised by ŠKODA AUTO A. S. ŠKODA AUTO A. S. does not guarantee or accept any liability with respect to the correctness of information in this document. Copyright by ŠKODA AUTO A. S. ©



- Carefully release retaining tabs -arrows- and pull off return ring with coil spring -1- from the switch mounting on the steering column.

Installing

Installation is carried out in the reverse order. When installing, observe the following:



Note

- ◆ Vehicles manufactured as of CW 22/06 have no locking pin, which could lock the restoring ring against unintentional turning after removing the steering wheel. In case of doubt about the correct positioning of the ring rotor, the middle position of the return ring must be set before installing the steering wheel ⇒ [page 144](#) .
- ◆ When installing, the return ring with coil spring must be in the middle position and the wheels in the straight ahead position.

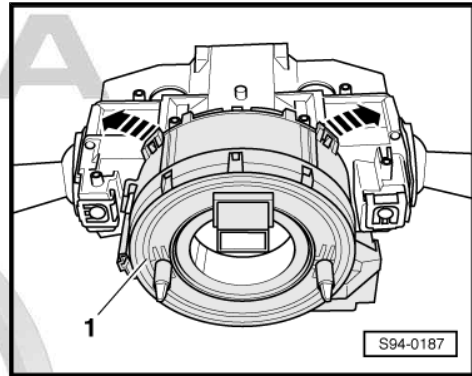

7.1.4 Removing and installing steering angle sender - G85-



Note

Protected by copyright. Copying for private or commercial purposes, in part or in whole, is not permitted unless authorised by SKODA AUTO A. S. SKODA AUTO A. S. does not guarantee or accept any liability with respect to the correctness of information in this document. Copyright by SKODA AUTO A. S. ©

- ◆ After replacing the steering angle sender - G85- subsequently the basic setting must be carried out with the ⇒ *Vehicle diagnostic tester*.
- ◆ Right-hand drive as of CW 22/08 and left-hand drive as of CW 22/09 - steering wheel sender - G85- integrated in the steering gear

Removing

- Remove restoring ring with coil spring - F350- ⇒ [page 135](#) .
- Detach steering angle sender -G85- -1- in -direction of arrow-.

Installing

The installation occurs in reverse order.

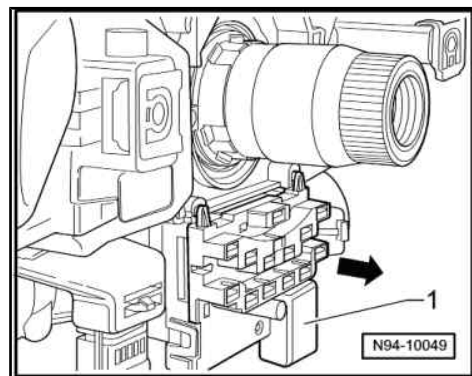

7.1.5 Removing and installing lever key of switch mounting on the steering column

Special tools and workshop equipment required

- ◆ Feeler gauge

Removing

- Remove restoring ring with coil spring - F350- ⇒ [page 135](#) .
- Remove steering angle sender - G85- ⇒ [page 136](#) (if present).

i Note

The following operations are shown on a removed steering column switch for purposes of clear presentation.

- Unlock the retaining lugs -arrows- with feeler gauge 1.0 mm -1- and remove the left level key in the -direction of arrow A-.

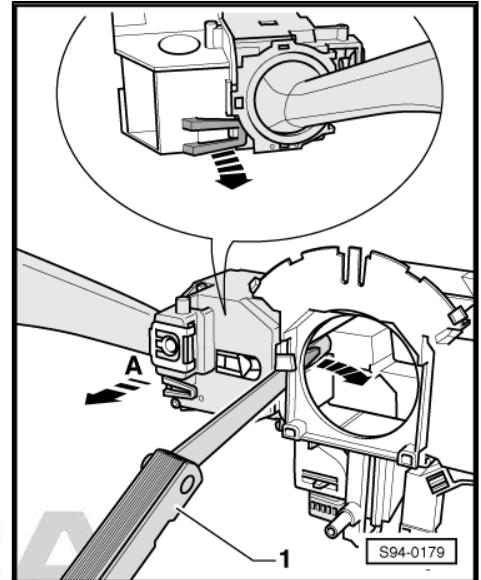

- Unlock the retaining lugs -arrows- with feeler gauge 1.0 mm -1- and remove the right level key in the -direction of arrow A-.

Installing

Installation is carried out in the reverse order. When installing, observe the following:

- Make sure that all the retaining lugs lock in place correctly.

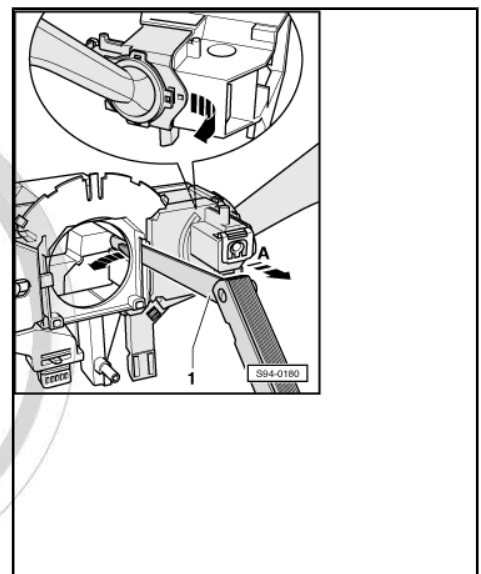

7.1.6 Removing and installing switch mounting on the steering column

Information in this document, including technical drawings, is part of the technical information of SKODA AUTO A. S. SKODA AUTO A. S. does not guarantee or accept any liability for the use of the information in this document. Copyright by SKODA AUTO A. S.

i Note

The fixing screws of the steering lock must be bored out in order to remove the switch mounting on the steering column. New pull-off screws are required for later installation => Electronic Catalogue of Original Parts .



WARNING

When boring out the screws splinters can penetrate into the surrounding components and can cause damage and/or functional problems. Thus it is purposeful to remove these components before boring out the screws.

Removing

Remove the following components consecutively as follows:

- Steering wheel ➔ Body Work; Rep. gr. 69 .
- Top and bottom steering column trim panel ➔ Body Work; Rep. gr. 70 .
- Steering column electronics control unit - J527- ➔ [page 134](#) .
- Return ring with coil spring - F350- ➔ [page 135](#) .
- Steering angle sender - G85- ➔ [page 136](#) (if present).
- Left and right lever key ➔ [page 136](#) .
- Disconnect plug connection from the reader coil -arrow-

Bore out fixing screws -1- for steering lock with lock cylinder and ignition lock -3-

- Slide switch mounting -2- with steering lock out of the steering column.

Protected by copyright. Copying for private or commercial purposes, in part or in whole, is not permitted unless authorised by ŠKODA AUTO A. S. ŠKODA AUTO A. S. does not guarantee or accept any liability with respect to the correctness of information in this document. Copyright by ŠKODA AUTO A. S. ©

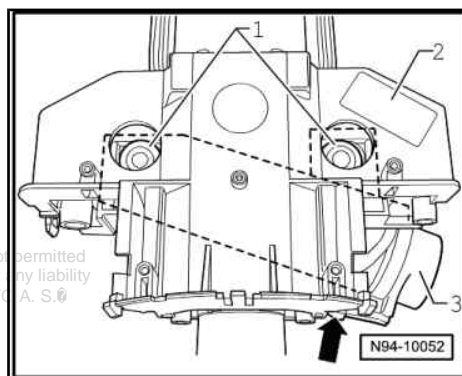

- Release the retaining lugs -arrows- and remove the steering lock housing -2- from the mounting -1-.

Installing

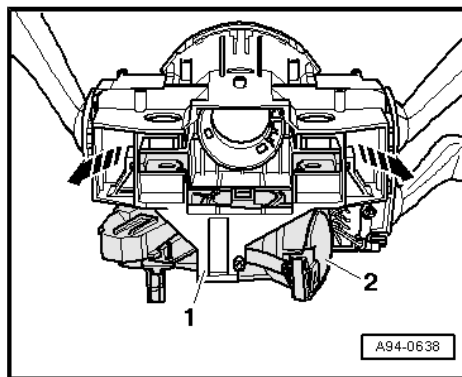

- Insert steering lock with lock cylinder and ignition lock -3- into the switch mounting -2-.
- Fit switch mounting with steering lock as far as possible onto the steering column.
- Insert plug connection -arrow- into the reader coil at the lock cylinder.
- Screw on steering lock with new pull-off screws -1- and tighten until the screw heads are torn off.
- Install the other components in reverse order.

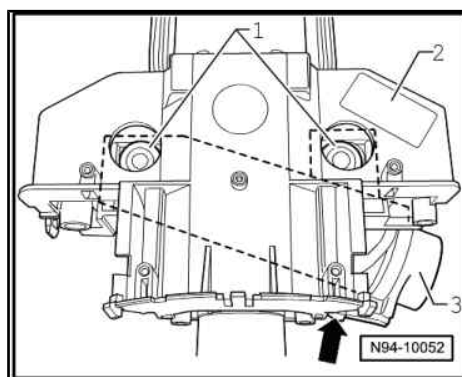

7.1.7 Contact assignment on the steering column electronics control unit - J527-

A - Plug for turn signal lights/ cruise control system

- 1 - Voltage supply (terminal 15)
- 2 - "off" - latched position
- 3 - Res ("+")/Set ("-")
- 4 - on - latched position/off - inflexible position
- 5 - Earth
- 6 - not assigned
- 7 - Headlight flasher
- 8 - Main beam
- 9 - Turn signals
- 10 - Tun signals, earth

B - Plug for vehicle voltage control unit - J519-

- Contact assignment
⇒ [page 141](#)

C - Plug for airbag control unit

- Contact assignment
⇒ [page 141](#)

D - Plug for ignition starter switch

- 1 - not assigned
- 2 - not assigned
- 3 - Ignition key anti-removal lock on, terminal 30
- 4 - Ignition key anti-removal lock, earth
- 5 - not assigned
- 6 - not assigned
- 7 - Input of ignition/starter switch, terminal 50
- 8 - Terminal 30 voltage supply to ignition/starter switch
- 9 - Input of ignition/starter switch, terminal S
- 10 - Input of ignition/starter switch, terminal X
- 11 - Input of ignition/starter switch, terminal P
- 12 - Input of ignition/starter switch, terminal 15

E - Plug for windscreen wiper/multi-function display

- 1 - Signal of switch for windscreen wiper
- 2 - Earth, wiper

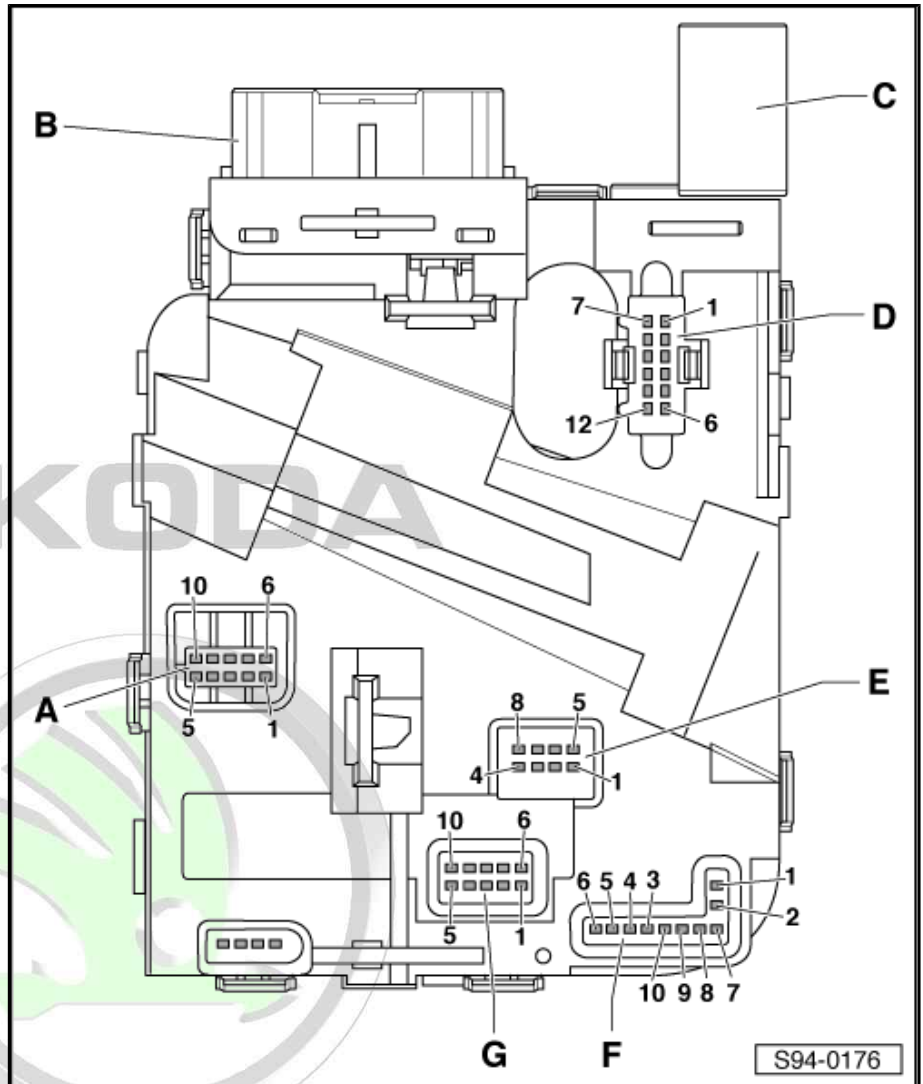

Protected by copyright. Copying for private or commercial purposes, in part or in whole, is not permitted unless authorised by ŠKODA AUTO A. S. ŠKODA AUTO A. S. does not guarantee or accept any liability with respect to the correctness of information in this document. Copyright by ŠKODA AUTO A. S. ©



- 3 - Rear wiping/washing signal
- 4 - not assigned
- 5 - Multi-function display signal
- 6 - Earth, multi-function display/interval potentiometer
- 7 - Input of regulator for the windscreen wiper interval stages
- 8 - not assigned

F - Plug for restoring ring

- 1 - Steering wheel heater “-”
- 2 - Steering wheel heater “+”
- 3 - Airbag “+”
- 4 - Airbag “-”
- 5 - not used
- 6 - not used
- 7 - Earth, multi-function steering wheel and horn
- 8 - CCS latched “off”/horn signal
- 9 - LIN bus/Temperature signal for steering wheel heater
- 10 - Terminal 15 for multi-function steering wheel

G - Plug for steering angle sender

- 1 - Light barrier 5
- 2 - Light barrier 3
- 3 - Light barrier 1
- 4 - 12 V voltage supply
- 5 - 5 V voltage supply
- 6 - Light barrier 6
- 7 - Light barrier 4
- 8 - Light barrier 2
- 9 - Earth steering angle sender
- 10 - Light barrier 7

ŠKODA

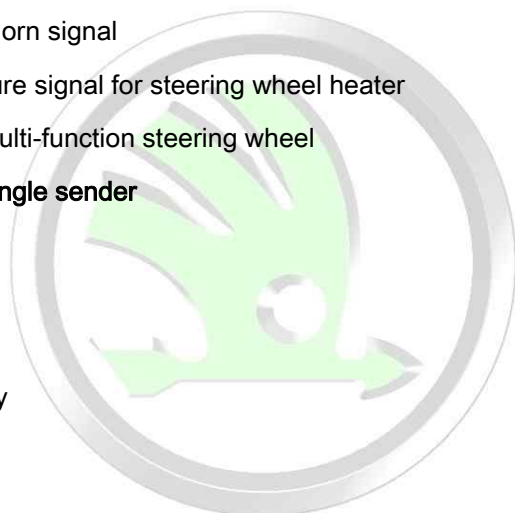

Protected by copyright. Copying for private or commercial purposes, in part or in whole, is not permitted unless authorised by ŠKODA AUTO A. S. ŠKODA AUTO A. S. does not guarantee or accept any liability with respect to the correctness of information in this document. Copyright by ŠKODA AUTO A. S.

Twenty-pin plug -B-

- 1 - Taxi two-way radio 2
- 2 - Taxi two-way radio 1
- 3 - Taxi alarm 2
- 4 - Taxi alarm 1
- 5 - 10 - not assigned
- 11 - Drive CAN bus low
- 12 - Drive CAN bus high
- 13 - CCS - "off" - latched position
- 14 - Convenience system CAN bus high
- 15 - Convenience system CAN bus low
- 16 - P-IN (P contact of gear selector lever)
- 17 - Output terminal 15
- 18 - Output terminal 50
- 19 - Terminal 30
- 20 - Terminal 31

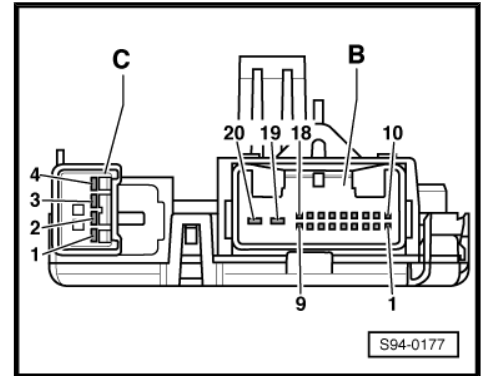

Plug for airbag control unit -C-

- 1 - Airbag "-"
- 2 - Airbag "+"
- 3 - not used
- 4 - not used

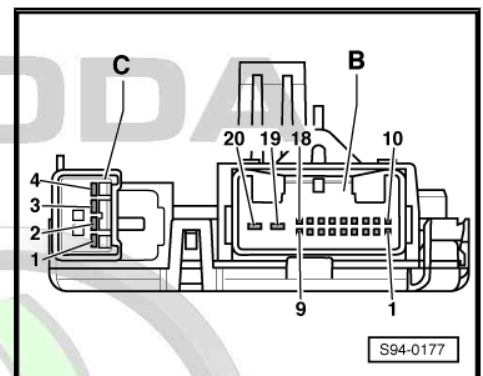

7.2 Steering column switch- vehicles as of CW 22/10

⇒ ["7.2.1 Summary of components of steering column switch", page 141](#)

⇒ ["7.2.2 Removing and installing return ring with coil spring F350 with integrated steering column electronics control unit J527", page 142](#)

⇒ ["7.2.3 Removing and installing steering column combination switch", page 143](#)

⇒ ["7.2.4 Contact assignment on the steering column electronics control unit J527", page 144](#)

unless authorised by ŠKODA AUTO A. S. ŠKODA AUTO A. S. does not guarantee or accept any liability with respect to the correctness of information in this document. Copyright by ŠKODA AUTO A. S. ©

7.2.1 Summary of components of steering column switch



Note

The steering column electronics control unit - J527- , steering column combination switch - E595- and base holder for steering column switch components are designed according to the manufacturer (Valeo or Kostal). The summary of components illustration shows the Valeo manufacturer's design.

**1 - Return ring with coil spring
- F350- with integrated steering
column electronics control
unit - J527-**

- ◆ Removing and installing
⇒ [page 142](#)

**2 - Steering column combina-
tion switch**

- ◆ Removing and installing
⇒ [page 143](#)

**3 - Switch carrier on the steer-
ing column**

- Removing and installing
⇒ [page 146](#)

4 - Pull-off screws

- Breakaway torque ap-
prox. 15 Nm

5 - Steering lock housing

- Removing and installing
⇒ [page 146](#)

6 - Ignition starter switch

- Removing and installing
⇒ [page 147](#)

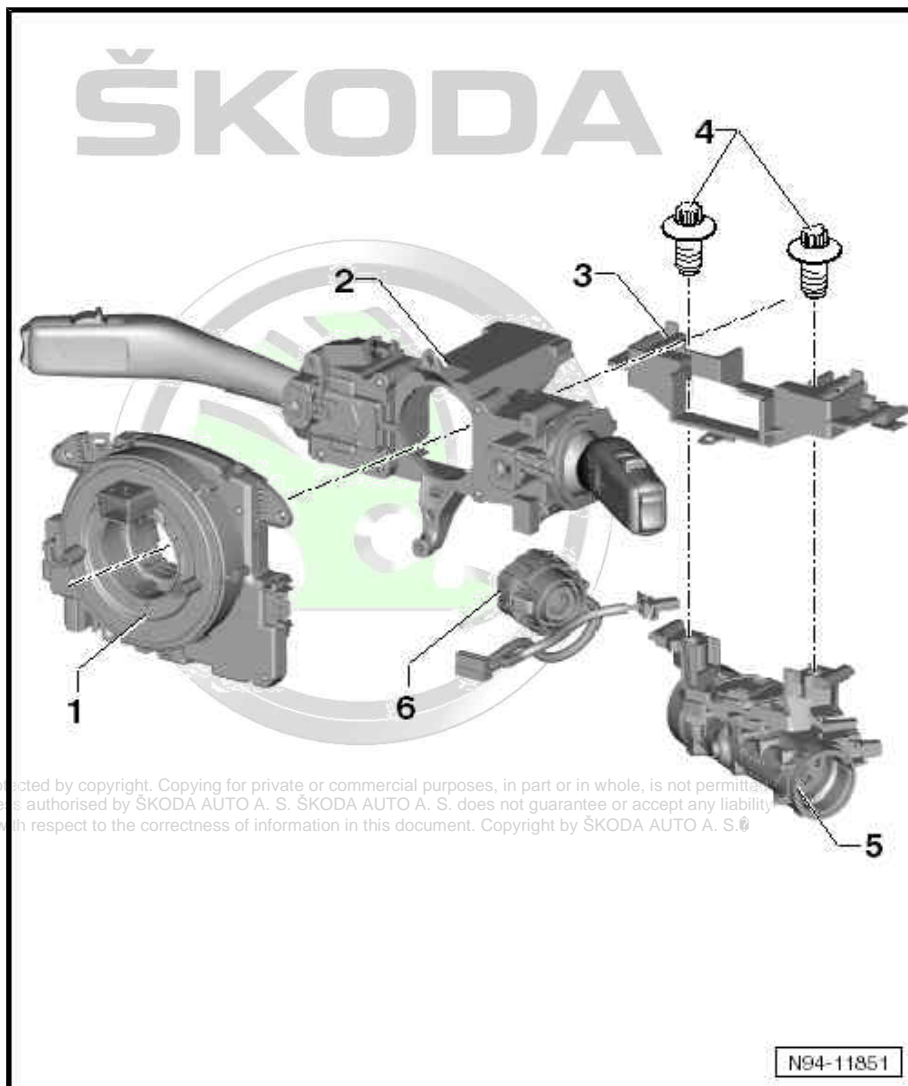

**7.2.2 Removing and installing return ring with
coil spring - F350- with integrated steer-
ing column electronics control
unit -
J527-**

Removing

- Remove steering wheel ⇒ Body Work; Rep. gr. 69 . Before the steering wheel is removed from the steering column, the wheels must be in the straight ahead position.
- Removing top and bottom steering column trim ⇒ Body Work; Rep. gr. 70 .

- Lock the return ring -4- in the centre position (plug -3- is in the middle at the top) with adhesive tape -2-, if necessary with transport security.

Manufacturer Valeo

- Unscrew screws -arrows- (1.5 Nm), pull off plug -1- and push restoring ring with control unit -4- off the steering column.

Kostal manufacturer

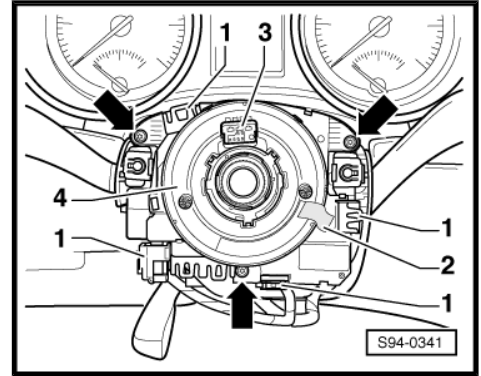

- Depending on equipment - unlock plug connections -1-, -2-, -3-, -4- und -5- and pull off.
- Unscrew screw -arrow B- (1.5 Nm).
- Unlock catch pegs -arrows A- and push restoring ring with control unit off the steering column.

Installing

Installation is carried out in the reverse order. When installing, observe the following:

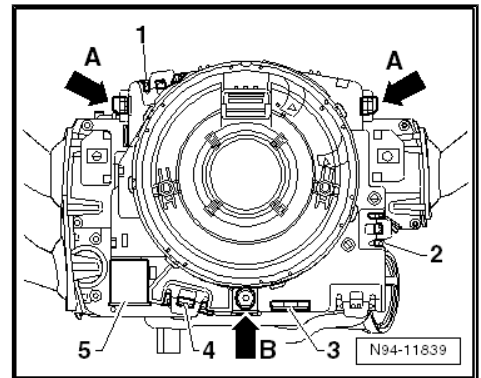

Note

- ◆ *When installing, the return ring with coil spring must be in the middle position and the wheels in the straight ahead position. In case of doubt about the correct positioning of the ring rotor, the middle position of the return ring must be set before installing the steering wheel ⇒ [page 144](#) .*
- ◆ *The indicator lever must be in the zero position so that the restoring segment does not protrude and break as a result.*
- ◆ *Kostal manufacturer - catch pegs -arrows A- must audibly click into place.*
- ◆ *The new control unit must be coded after the installation see ⇒ [Vehicle diagnostic tester](#).*

7.2.3 Removing and installing steering column combination switch

Removing

Note

The steering column is not shown in the illustration for purposes of clear presentation.

- Remove steering wheel ⇒ [Body Work; Rep. gr. 69](#) . Before the steering wheel is removed from the steering column, the wheels must be in the straight ahead position.
- Removing top and bottom steering column trim ⇒ [Body Work; Rep. gr. 70](#) .
- Remove return ring with coil spring ⇒ [page 142](#) .

Valeo manufacturer:

- Insert a small cross-head screwdriver through the opening -arrow A- and unlock the bottom catch peg.
- Press the top catch pegs -arrows B- and push the combination switch -1- out of the bearing on the steering lock -arrows C-.

Kostal manufacturer:

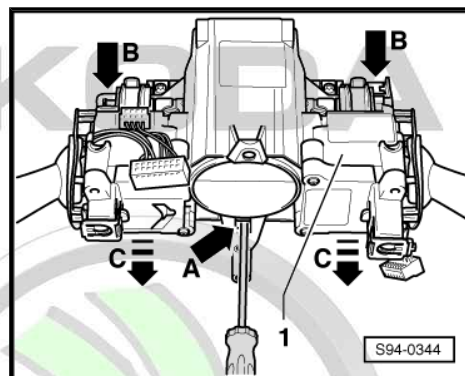

- Screw out the screw -arrow- (1 Nm) and push the combination switch -1- out of the bracket on the steering lock.

Installing

Installation is carried out in the reverse order. When installing, observe the following:

- Make sure that all the retaining lugs and plug connections lock in place correctly.

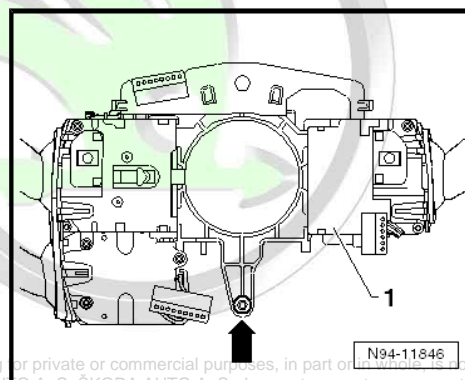

Protected by copyright. Copying for private or commercial purposes, in part or in full, is permitted unless authorised by ŠKODA AUTO A.S. for educational or research purposes. ŠKODA AUTO A.S. assumes no liability with respect to the correctness of information in this document. Copyright by ŠKODA AUTO A. S. ©

7.2.4 Contact assignment on the steering column electronics control unit - J527-

You can find the current contact assignment in the ⇒ Current flow diagrams, Electrical fault finding and Fitting locations.

7.3 Setting middle position of the return ring with coil spring

It is only carried out if there is a doubt about the correct setting of the centre position for the return ring rotor.

Work procedure

- Put the front wheels in straight ahead position.
- Slowly turn the ring rotor manually to the right up to the stop.
- Slowly turn the ring rotor manually to the left up to the stop and count the number of turns.
- Slowly turn the ring rotor to the right by half of the counted turns in the centre position (top connector must be in horizontal position).
- Install steering wheel ⇒ Body Work; Rep. gr. 69 , if necessary lock ring rotor with transport security or adhesive tape.

8 Steering lock with ignition starter switch and lock cylinder

⇒ [“8.1 Removing and installing lock cylinder”, page 145](#)

⇒ [“8.2 Removing and installing steering lock - vehicles up to CW 21/10”, page 146](#)

⇒ [“8.3 Removing and installing steering lock - vehicles as of CW 22/10”, page 146](#)

⇒ [“8.4 Removing and installing ignition/starter switch”, page 147](#)

⇒ [“8.5 Removing and installing ignition key anti-removal lock solenoid N376”, page 148](#)

⇒ [“8.6 Contact assignment on the ignition/starter switch and the ignition key anti-removal lock”, page 149](#)

8.1 Removing and installing lock cylinder



WARNING

The steering lock must not be moved without the lock cylinder, otherwise it would block completely. The blocked steering lock must be replaced

Protected by copyright. Copying for private or commercial purposes, in part or in whole, is not permitted unless authorised by ŠKODA AUTO A. S. ŠKODA AUTO A. S. does not guarantee or accept any liability with respect to the correctness of information in this document. Copyright by ŠKODA AUTO A. S.

Removing

- Disconnect battery earth strap ⇒ [page 2](#) .



Note

The steering wheel must not be removed. For installing the fixing screws of the bottom trim panel for steering column, turn the steering wheel to the left by 90° and subsequently turn it to the right.

- First of all remove the top and then the bottom steering column trim panel ⇒ Body Work; Rep. gr. 70 .
- Place the ignition key in the lock cylinder and turn to position “Ignition on” -2-.
- Lead a steel cable (about 1.2 mm in diameter) through the hole in the ignition key -arrow-.

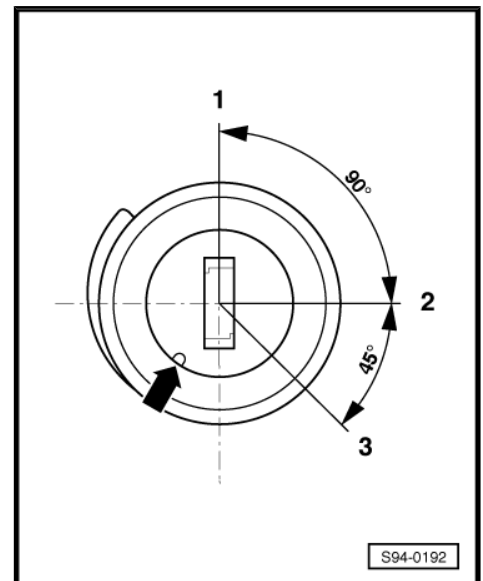

- Use the steel cable -2- to unlock the securing lever -3- of the lock cylinder -arrow- and to pull the lock cylinder out of the steering lock. For this step carefully slacken the cable to the reader coil of the vehicle immobiliser.

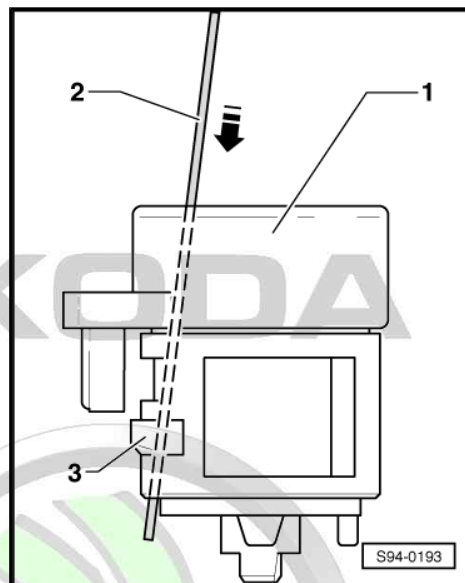

- Separate plug connection for immobiliser -1-.



Note

The reader coil for the vehicle immobiliser is fixed to the lock cylinder and cannot be replaced separately.

Installing

- Place the ignition key in the lock cylinder and turn to position "Ignition on".
- Fit the connector together on the reading coil for immobiliser.
- Insert the lock cylinder with the reader coil into the steering lock housing until it clicks audibly into place.

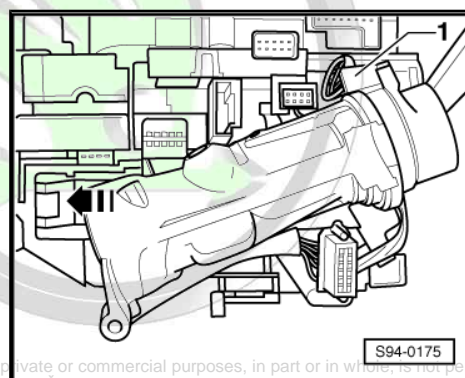

Note

Pay attention to the correct position of the cable to the reader coil of the vehicle immobiliser when inserting the lock cylinder.

- Fitting steering column trim ⇒ Body Work; Rep. gr. 70 .
- Follow the work procedure when connecting the battery ⇒ [page 2](#) .

8.2 Removing and installing steering lock - vehicles up to CW 21/10

The work sequence for removing and installing the steering lock is the same as for the switch mounting ⇒ [page 137](#) .

8.3 Removing and installing steering lock - vehicles as of CW 22/10

Removing

- Remove steering wheel ⇒ Body Work; Rep. gr. 69 , bottom and top steering column trim panel ⇒ Body Work; Rep. gr. 70 .
- Remove return ring with coil spring ⇒ [page 142](#) .

- Remove steering column combination switch ⇒ [page 143](#) .
- Disconnect the plug from the ignition starter switch and from the reader coil.
- Bore out fixing screws -1- and remove steering lock -3- with carrier of combination switch -2-.

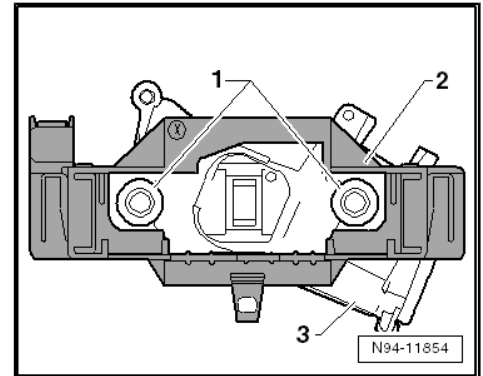

- Press off catches -arrows- and remove carrier of combination switch -1- from steering lock housing -2-.

Installing

Installation is carried out in the reverse order. When installing, observe the following:

- Screw on steering lock with new pull-off screws and tighten until the screw heads are torn off.
- Make sure that all the retaining lugs and plug connections lock in place correctly.

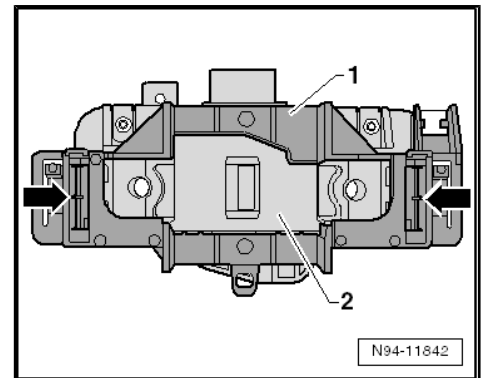

8.4 Removing and installing ignition/starter switch

Removing

- Disconnect battery earth strap ⇒ [page 2](#) .



Note

The steering wheel must not be removed. For installing the fixing screws of the bottom trim panel for steering column, turn the steering wheel to the left by 90° and subsequently turn it to the right.

- First of all remove the top and then the bottom steering column trim panel ⇒ Body Work; Rep. gr. 70 .
- Release cover -1- (if present) for ignition starter switch by inserting a small screwdriver in the opening -arrow- and lift off the cover -movement arrow- through extensive levering off and remove.
- Disconnect plug -3- from ignition starter switch -2-.

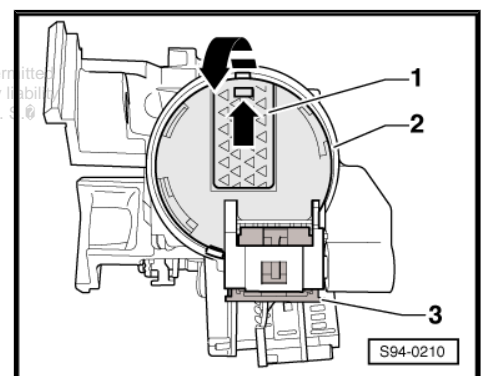



- Release ignition starter switch by inserting two small screwdrivers (e.g. watch-and-clock screwdriver) in the openings -arrows- and by levering off the catch pegs.
- Pull ignition starter switch -1- out of the steering lock.

Installing

Installation is carried out in the reverse order. When installing, observe the following:



Note

When installing the ignition/starter switch and the steering lock must be in the same position, e.g. "Ignition ON".

- Insert ignition starter switch into the steering lock until there is an audible click.
- Follow the work procedure when connecting the battery => [page 2](#) .

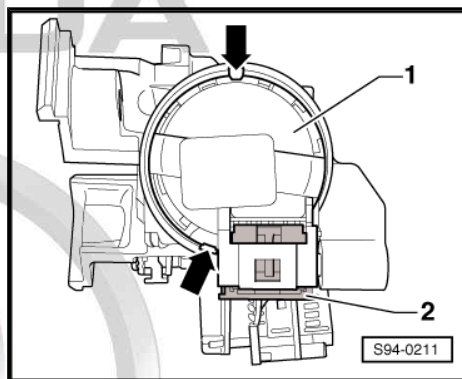

8.5 Removing and installing ignition key anti-removal lock solenoid - N376

...ate or commercial purposes, in part or in whole, is not permitted unless authorised by ŠKODA AUTO A. S. ŠKODA AUTO A. S. does not guarantee or accept any liability with respect to the correctness of information in this document. Copyright by ŠKODA AUTO A. S.

Only on vehicles equipped with automatic gearbox.

Removing



Note

The steering wheel must not be removed. For installing the fixing screws of the bottom trim panel for steering column, turn the steering wheel to the left by 90° and subsequently turn it to the right.

- First of all remove the top and then the bottom steering column trim panel => Body Work; Rep. gr. 70 .
- Unlock catch -2- and pull out ignition key anti-removal lock magnet -1- out of the clamp in direction of the arrow.
- To do so unplug the connector simultaneously.

Installing

The installation occurs in reverse order.

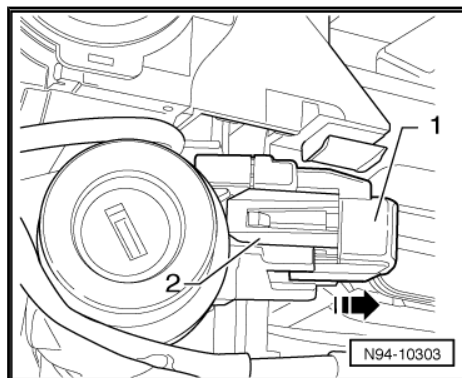

8.6 Contact assignment on the ignition/ starter switch and the ignition key anti- removal lock

2-pin plug on the ignition key anti-removal lock -A- (for automatic transmission vehicles)

- 1 - Ignition key anti-removal lock in, terminal 30
- 2 - Ignition key anti-removal lock earth

6-pin plug at ignition starter switch -B-



Note

The contacts -1- and -6- are marked on the 6-pin plug.

- 1 - Ignition/starter switch output, terminal 50
- 2 - Terminal 30 voltage supply to ignition/starter switch
- 3 - Ignition/starter switch output, terminal S
- 4 - Ignition/starter switch output, terminal X
- 5 - Ignition/starter switch output, terminal P
- 6 - Ignition/starter switch output, terminal 15

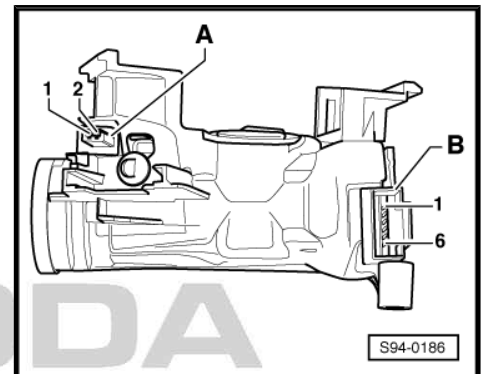

Protected by copyright. Copying for private or commercial purposes, in part or in whole, is not permitted unless authorised by ŠKODA AUTO A. S. ŠKODA AUTO A. S. does not guarantee or accept any liability with respect to the correctness of information in this document. Copyright by ŠKODA AUTO A. S. ©



9 Parking aid



Note

- ◆ *When handling a fault it is absolutely essential to know the function of the parking aid.*
- ◆ *Description of the system and the function ⇒ Owner's manual Octavia II and ⇒ Self-study programme No. 53 ; Škoda Octavia II introduction of vehicle .*
- ◆ *Contact assignment on the control unit as well as connection of components of parking aid can be found in ⇒ Current flow diagrams, Electrical fault finding and Fitting locations.*

⇒ ["9.1 Summary of components", page 150](#)

⇒ ["9.2 Removing and installing the parking aid control unit J446", page 151](#)

⇒ ["9.3 Removing and installing the rear parking aid warning buzzer H15", page 152](#)

⇒ ["9.4 Remove and install the front parking aid warning buzzer H22", page 152](#)

⇒ ["9.5 Removing and installing parking aid senders", page 153](#)

⇒ ["9.6 Parking aid sender holder - making holes, assignment, fitting location, glueing procedure", page 154](#)

⇒ ["9.7 Self-diagnosis of the parking aid", page 155](#)

9.1 Summary of components



Note

Protected by copyright. Copying for private or commercial purposes, in part or in whole, is not permitted without the prior written consent of ŠKODA AUTO A. S. ŠKODA AUTO A. S. does not warrant or accept any liability with respect to the correctness of information in this document. Copyright by ŠKODA AUTO A. S. ©

Summary of details for the components ⇒ [Electronic Catalogue of Original Parts](#) .

1 - Rear parking aid sender

- below the protective strip of the rear shock absorber
- Removing and installing
⇒ [page 153](#)

2 - Control unit for the parking aid - J446-

- behind the left luggage compartment trim panel
- Removing and installing
⇒ [page 151](#)

3 - Rear parking aid warning buzzer - H15-

- in the trim panel of pillar B
- Removing and installing
⇒ [page 152](#)

4 - Front parking aid sender

- below the protective strip of the front shock absorber
- Removing and installing
⇒ [page 153](#)

5 - The warning buzzer for the front parking aid - H22-

- behind the right dash panel insert
- Removing and installing
⇒ [page 152](#)
- installed in vehicles as of MY 09

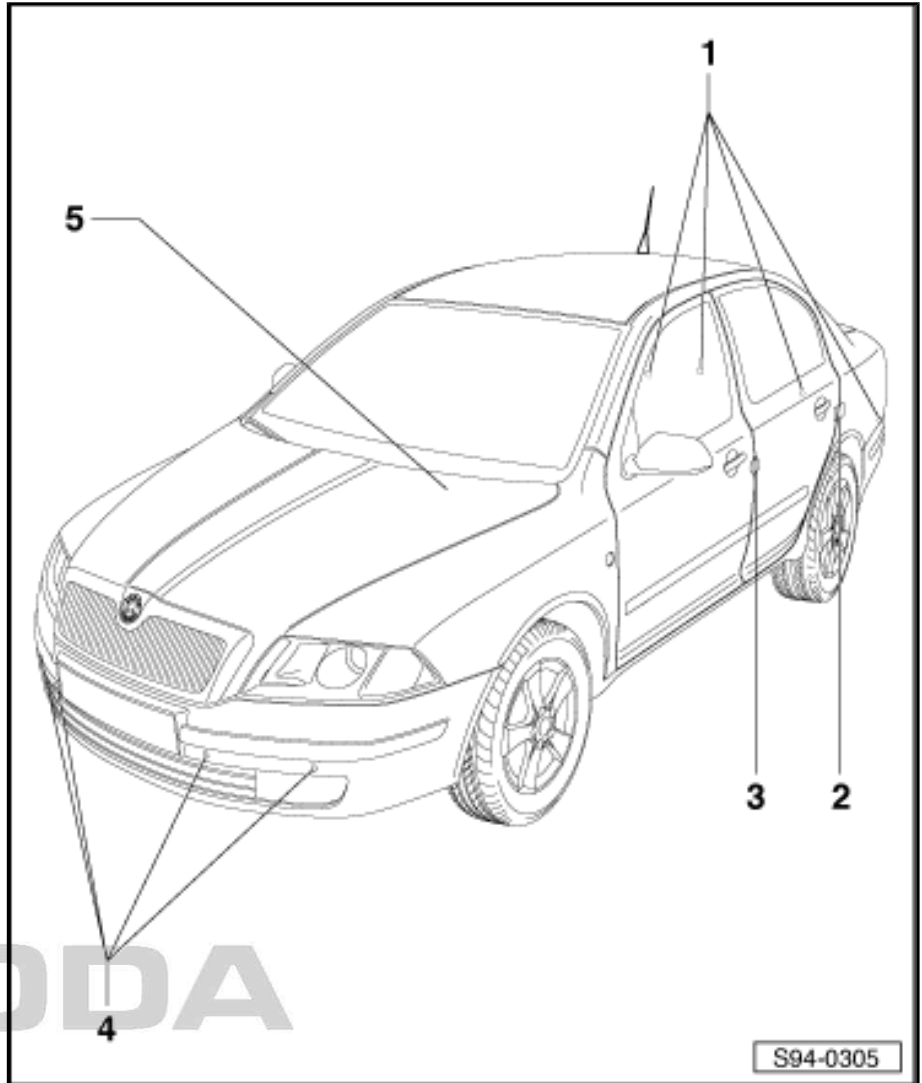

9.2 Removing and installing the parking aid control unit - J446-

Removing

- Switch off the ignition and all electrical consumers!
- Remove right side trim panel in luggage compartment ⇒ Body Work; Rep. gr. 70 .
- Release and disconnect the plug connections.
- Release nuts -arrows- (1.5 Nm) and take out parking aid control unit.

Installing

Installation is carried out in the reverse order. When installing, observe the following:

- When replacing, code the new parking aid control unit - J446- ⇒ [Vehicle diagnostic tester](#).

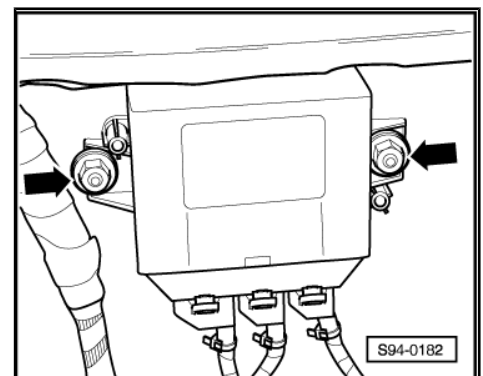

9.3 Removing and installing the rear parking aid warning buzzer - H15-

Removing

- Switch off the ignition and all electrical consumers!
- Remove bottom left trim panel of pillar B ⇒ Body Work; Rep. gr. 70 .
- Disconnect plug connection -2-.
- Remove button rivets -arrows-.
- Disconnect parking aid warning buzzer -1-.

Installing

The installation occurs in reverse order.

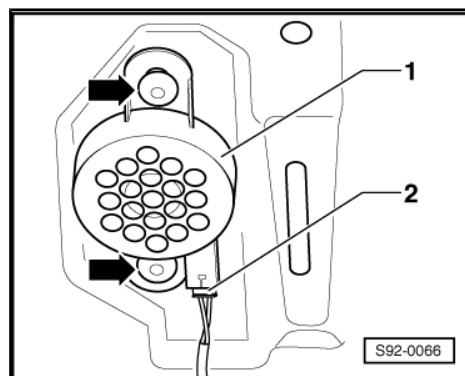

9.4 Remove and install the front parking aid warning buzzer - H22-

Installed in vehicles as of MY 09.

The front parking aid warning buzzer is located behind the right dash panel insert.

Removing

- Remove dash panel insert ⇒ [page 22](#) .
- Disconnect the plug from the warning buzzer.
- Remove expanding rivets -1- and remove warning buzzer -2-.

Installing

The installation occurs in reverse order.

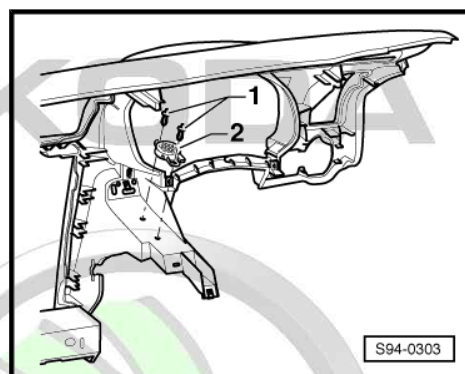

9.5 Removing and installing parking aid senders

Note

- ◆ *The visible area of a new sender must be painted in the colour of the bumper before installing.*
- ◆ *The parking aid senders must only be painted with a max. 100 µm thick layer of paint. Before painting the sender, the rear parts of the sender (terminal connection) must be affixed.*
- ◆ *Only the upper part (visible part) of the sender membrane is painted.*
- ◆ *To make it easier to remove the catches -arrow A- you can use a larger set of Seeger pliers with angled jaws.*

Removing front sender

- Switch off the ignition and all electrical consumers!
- Remove front bumper ⇒ Body Work; Rep. gr. 63 .
- Pull off retaining catches on sender -arrows A-.
- Press out the sender -1- on the outer side of the shock absorber inwards.
- Disconnect plug connection -2-.

Remove rear sender

Note

Before the plug connections are disconnected from the senders and the wiring loom is loosened, the left and right wiring loom side has to be marked so that no undesirable change can occur when installing. On vehicles where the distance and location of the obstacle (left/right) is shown in the radio display (e.g. radio "Stream" or "Audience") the obstacle would be indicated on the wrong side.

- Switch off the ignition and all electrical consumers!
- Remove rear bumper ⇒ Body Work; Rep. gr. 63 .
- Pull off retaining catches on sender -arrows A-.
- Press out the sender -1- on the outer side of the shock absorber inwards.
- Disconnect plug connection -2-.

Installing

The installation occurs in reverse order.

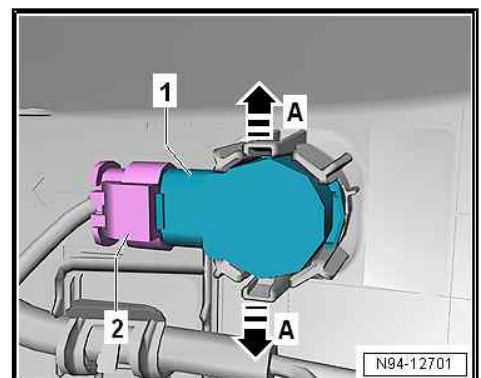
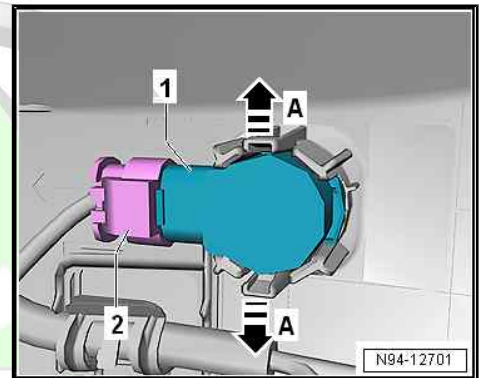



9.6 Parking aid sender holder - making holes, assignment, fitting location, glueing procedure

If the bumper is replaced, new sender holders must be affixed to the new bumper.

Make holes in the new bumper see ⇒ Body Work; Rep. gr. 63 .

⇒ [“9.6.1 Assignment of the sender holder”, page 154](#)

⇒ [“9.6.2 Fitting position of the sender holders”, page 154](#)

⇒ [“9.6.3 Gluing procedure of the sender holders”, page 155](#)

9.6.1 Assignment of the sender holder

The sender holders are different in shape and must be assigned to the relevant fitting location. The inner and outer sender holders are not identical. Assignment of the sender holders according to construction year ⇒ Electronic Catalogue of Original Parts .



Note

- ◆ *Vehicles up to MY 08 - if the front sender holders are replaced, the holder with the marking “P-VNI-P” is glued on the left inner side and with the marking “P-VNI-L” on the right inner side of the bumper on Octavia Scout and RS vehicles. On other vehicles the holder with the marking “P-VNI-P” is glued on the right inner side and with the marking “P-VNI-L” on the left inner side of the bumper.*
- ◆ *Vehicles as of MY 09 - both inner sender holders are identical, there is no difference between the left and the right.*

9.6.2 Fitting position of the sender holders

The fitting position is determined by the peg on the holder -2- and the contour of the holder on the bumper -1-.

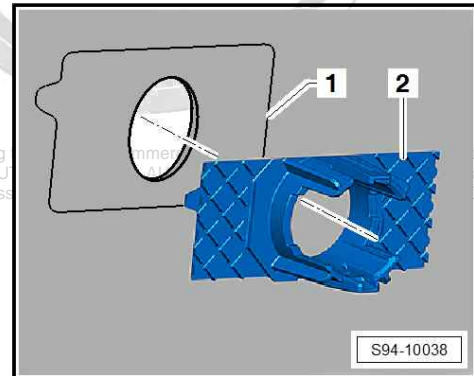

Protected by copyright. Copying
unless authorised by ŠKODA AU
with respect to the correctness

permitted
any liability
A. S. ©

9.6.3 Gluing procedure of the sender holders

i Note

- ◆ Vehicles up to MY 08 and all vehicles Octavia RS and Scout - the sender holders have a submerged flange, its visible area -1- must be painted in the colour of the bumper.
 - ◆ Vehicles as of MY 09 (except for Octavia RS and Scout) - the sender holders do not have a submerged flange -1-. Therefore a centering pin must be used for precisely centering the holder in the bumper or gluing the holder with inserted parking aid sender on which the decoupling ring (black silicone ring) is placed.
 - ◆ The temperature of the bumper and the sender holder must be between 15 °C and 30 °C during the gluing procedure.
- Clean and thoroughly degrease the marked adhesive area -1- with isopropyl (technical alcohol).
 - Evenly apply activator "3M glass/paint primer 4298UV", if necessary, "gas/paint primer K520" in the marked adhesive area -1-.
 - Let the activator dry off for approx. 5 min.

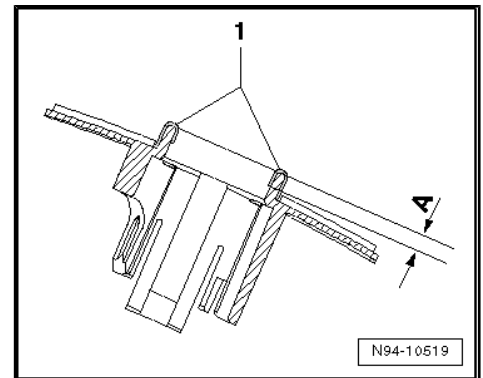

i Note

Protected by copyright. Copying for private or commercial purposes, in part or in whole, is not permitted unless authorized in writing by SKODA AUTO A. S. ©

◆ Pay attention to the fitting position ⇒ [page 154](#) and the assignment of the sender holders ⇒ [page 154](#).

- ◆ The application force and the application time determine the durability of the bonding!
- Remove the protective foils from both sides of the adhesive tape and press the sender holder -2- into the front bumper for approx. 10 seconds while applying high force.

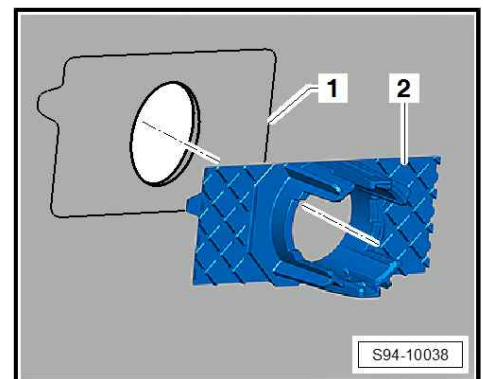

9.7 Self-diagnosis of the parking aid

The parking aid system is equipped with self-diagnosis. Carry out "self-diagnosis" with the ⇒ Vehicle diagnostic tester in the function "Targeted fault finding".

10 Door entry lighting

⇒ [“10.1 Door entry lighting in the exterior mirror - vehicles up to MY 08”, page 156](#)

⇒ [“10.2 Door entry lighting in the exterior mirror - vehicles as of MY 09”, page 156](#)

10.1 Door entry lighting in the exterior mirror - vehicles up to MY 08

Removing

- Switch off the ignition and all electrical consumers!
- Remove the mirror housing ⇒ Body Work; Rep. gr. 66 .
- Turn bulb socket -arrow- 90° and take out.
- Replace light bulb (W5W).

Installing

The installation occurs in reverse order.

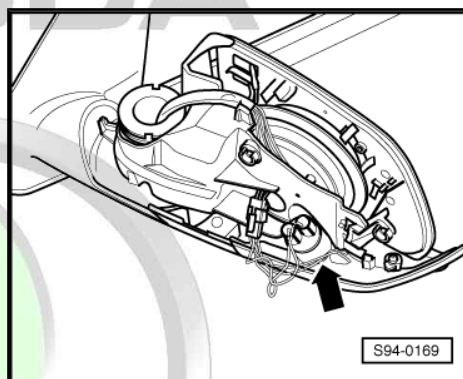

10.2 Door entry lighting in the exterior mirror - vehicles as of MY 09

⇒ [“10.2.1 Replace light bulb for the door entry lighting”, page 156](#)

⇒ [“10.2.2 Removing and installing door entry lighting”, page 156](#)

10.2.1 Replace light bulb for the door entry lighting

- Switch off the ignition and all electrical consumers!
- Remove mirror glass ⇒ Body Work; Rep. gr. 66 .
- Remove socket with light bulb -1- from the housing of the door entry lighting -arrow-.
- Remove defective light bulb (W5W) from the socket and replace.

The installation occurs in reverse order.

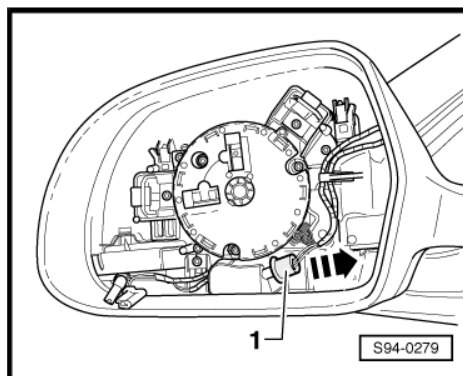

10.2.2 Removing and installing door entry lighting

Removing

- Switch off the ignition and all electrical consumers!

- Remove mirror glass ⇒ Body Work; Rep. gr. 66 .
- Release screws -1- and -3- (0.7 Nm).
- Slacken the upper exterior mirror cover -2- from the catches -arrows- and remove towards the top -movement arrows- from the mirror housing.

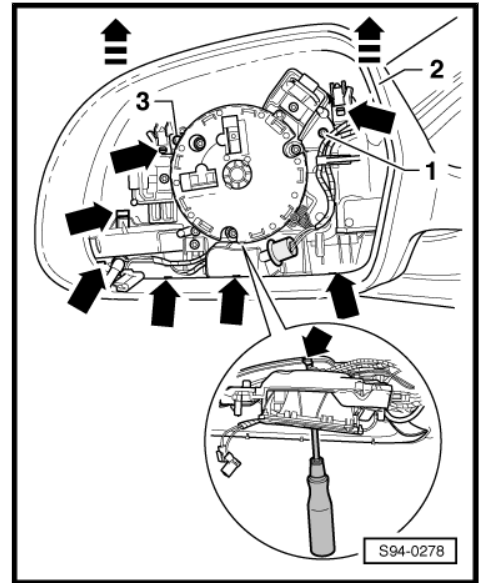

- Remove the socket with the light bulb -2- from the door entry lighting.
- Release screws -arrows- (0.8 Nm) and unhook the lower mirror housing cover -1- to the bottom.

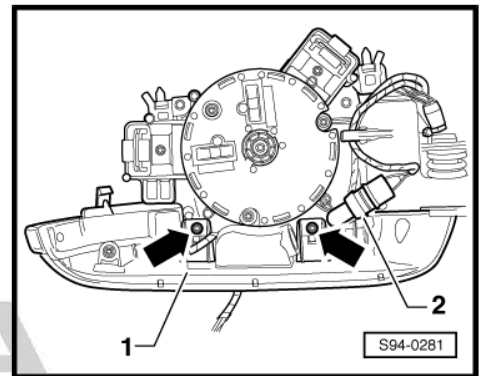

- Release screws -2- (0.5 Nm) and remove door entry lighting -3-.

Installing

Installation is carried out in the reverse order. When installing, observe the following:

- Perform a functional test (illumination, mirror adjustment).

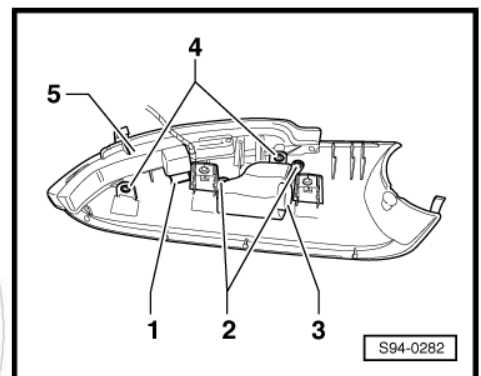

11 Registration number lighting

⇒ "11.1 Removing and installing licence plate carrier",
[page 158](#)

11.1 Removing and installing licence plate carrier

Removing

- Switch off the ignition and all electrical consumers!
- Unscrew the securing screws -arrows- in the light emission window (0,7 Nm).
- Remove the light.
- Remove the light bulb (C5W) from the clamping sleeve.

Installing

The installation occurs in reverse order.

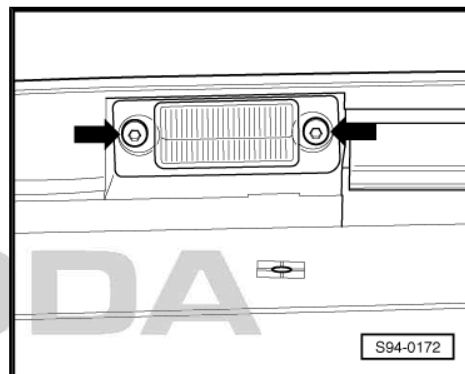

Protected by copyright. Copying for private or commercial purposes, in part or in whole, is not permitted unless authorised by ŠKODA AUTO A. S. ŠKODA AUTO A. S. does not guarantee or accept any liability with respect to the correctness of information in this document. Copyright by ŠKODA AUTO A. S. ©

96 – Lights, bulbs, switches - interior

1 Interior Lights

⇒ [“1.1 Removing and installing glove box light”, page 159](#)

⇒ [“1.2 Removing and installing door warning lamp”, page 159](#)

⇒ [“1.3 Removing and installing luggage compartment light”, page 160](#)

⇒ [“1.4 Removing and installing the front and rear interior light”, page 160](#)

⇒ [“1.5 Removing and installing the interior light with sliding roof switch”, page 161](#)

⇒ [“1.6 Removing and installing the sliding roof switch”, page 161](#)

1.1 Removing and installing glove box light

Removing

- Switch off the ignition and all electrical consumers!
- Use a cross-head screwdriver to grasp behind the lens and carefully lever out lamp.
- Replace light bulb C3W.

Installing



Note

Check fitting position. The switch contact of the lamp must point to the switch lever.

- Insert the lens with lamp socket in the glove box and lock into position.



1.2 Removing and installing door warning lamp

Removing

- Switch off the ignition and all electrical consumers!
- Use a cross-head screwdriver to grasp behind the lens and carefully lever out lamp.
- Disconnect the plug connection.
- Replace light bulb C5W.

Installing

The installation occurs in reverse order.

Protected by copyright. Copying for private or commercial purposes, in part or in whole, is not permitted unless authorised by ŠKODA AUTO A. S. ŠKODA AUTO A. S. does not guarantee or accept any liability with respect to the correctness of information in this document. Copyright by ŠKODA AUTO A. S. ©

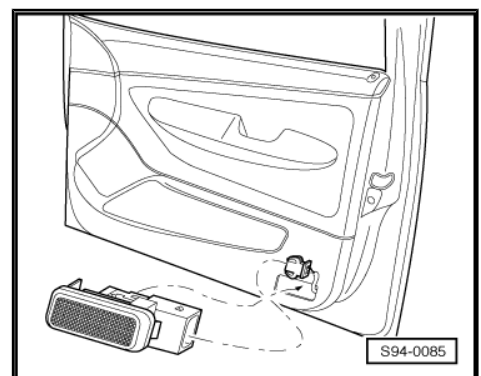

1.3 Removing and installing luggage compartment light

Removing

- Switch off the ignition and all electrical consumers!
- Use a cross-head screwdriver to grasp behind the lens and carefully lever out lamp.
- Disconnect the plug connection.
- Light bulb, vehicle-specifically, C5W or W5W.

Installing

The installation occurs in reverse order.

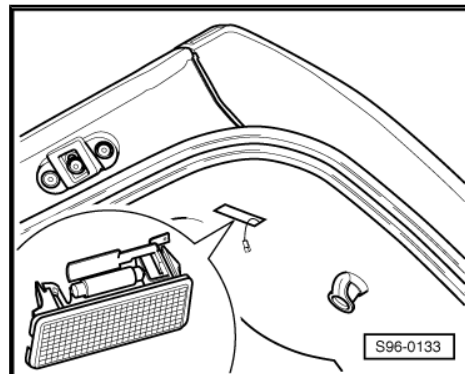

1.4 Removing and installing the front and rear interior light

The assembly work is identical for both lights, only the tightening torque is different.

Removing

- Switch off the ignition and all electrical consumers!
- Carefully lower light scattering cover -arrow- and remove.

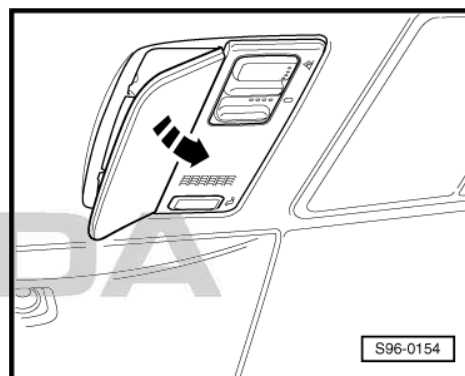

- Unscrew screws -1-.
- ◆ Front interior light: 2 Nm
- ◆ Rear interior light: 1 Nm
- Remove the interior light downwards and disconnect the connectors.

Note

It is necessary to not remove the interior light to replace the light bulb.

2 - Light bulb without base W5W

3 - Soffitte C10W

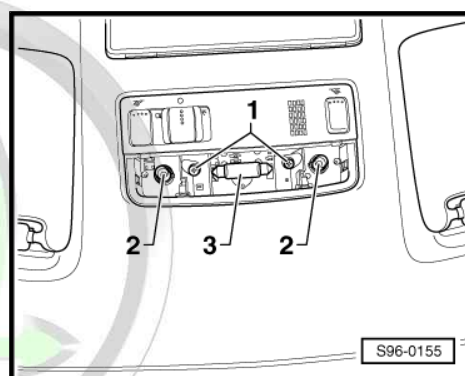

Installing

The installation occurs in reverse order.

Protected by copyright. Copying for private or commercial purposes, in part or in whole, is not permitted unless authorized by ŠKODA AUTO A. S. ŠKODA AUTO A. S. does not guarantee or accept any liability with respect to the correctness of information in this document. Copyright by ŠKODA AUTO A. S. ©

1.5 Removing and installing the interior light with sliding roof switch

Removing

- Switch off the ignition and all electrical consumers!
- Carefully remove front lens -arrow- downwards.

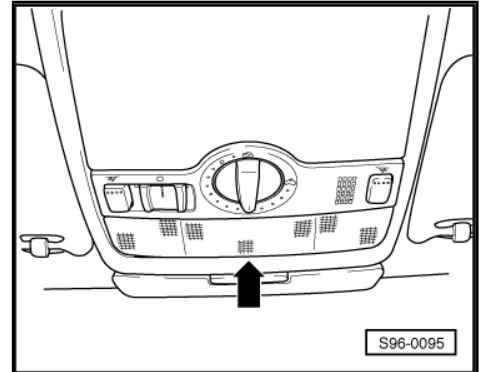

- Release screws - 1 - (2 Nm).
- Remove the interior light downwards and disconnect the plug connections.



Note

It is necessary to not remove the interior light to replace the light bulb.

- 2 - Light bulb without base W5W
- 3 - Soffitte C10W

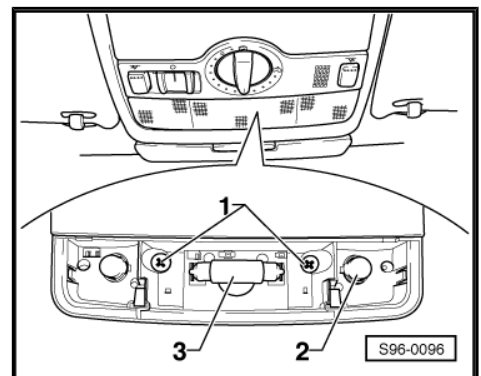

Installing

- Fit together the plug connections.
- Insert interior light with sliding roof switch and secure with the two cross-head screws (1.5 Nm).
- First of all insert lens with the catch lugs in the interior light slots and then press upwards to the noticeable latching.

1.6 Removing and installing the sliding roof switch

Removing

- Remove front interior light with sliding roof switch
⇒ [page 161](#) .
- Press off pegs -arrows- and remove sliding roof switch from the illumination housing.

Installing

The installation occurs in reverse order.

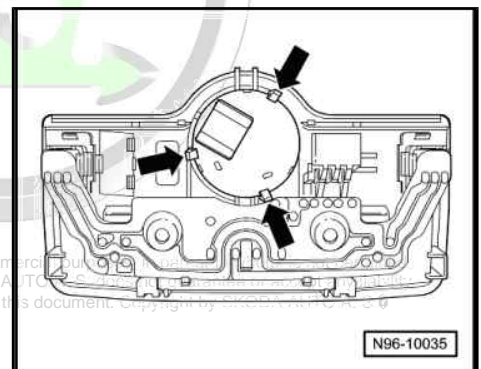

2 Interior switches, in the dash panel, the centre console and the doors

- ⇒ [“2.1 Removing and installing light switch”, page 162](#)
- ⇒ [“2.2 Removing and installing the headlight range control adjuster”, page 162](#)
- ⇒ [“2.3 Removing and installing switches in centre console”, page 163](#)
- ⇒ [“2.4 Removing and installing hazard warning lights button”, page 163](#)
- ⇒ [“2.5 Removing and installing the mirror adjustment switch”, page 164](#)
- ⇒ [“2.6 Removing and installing the switch for the power window lifter”, page 164](#)
- ⇒ [“2.7 Removing and installing interior monitoring deactivation switch E 267 and deactivation button for vehicle inclination sender E 360”, page 166](#)
- ⇒ [“2.8 Removing and installing switch for inside actuation of the central locking”, page 166](#)
- ⇒ [“2.9 Removing and installing the fuel selector switch E395 \(petrol/gas\)”, page 166](#)
- ⇒ [“2.10 Removing and installing the rear seat heating switch”, page 167](#)

2.1 Removing and installing light switch

Removing

- Switch off the ignition and all electrical consumers!
- Turn the turning handle of the light switch to position “0”.
- Press in the turning handle of the light switch firmly -arrow 1- and slightly turn it to the right -arrow 2-.
- Hold the turning handle in this position and pull the light switch housing out to the -front arrow 3-.
- Disconnect connector at switch.

Installing

- Mount plug.
- Carefully push the light switch into the opening until the switch audibly locks into place.

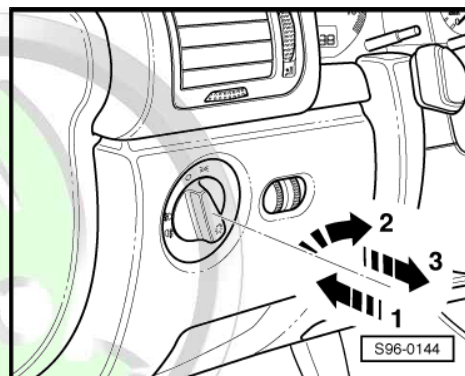

2.2 Removing and installing the headlight range control adjuster

Removing

- Switch off the ignition and all electrical consumers!
- Remove lower part of the dash panel insert on the driver's side
⇒ Body; Rep. gr. 70 Work.
- Disconnect the plug connections.

- Press together the lateral securing tabs on the adjuster for the headlamp range control -arrows-.
- Pull the adjuster for headlamp range control -A- to the rear out of the mounting frame in the dash panel casing.



Note

The adjuster for headlamp range control and instrument lighting rheostat form a single unit.

Installing

- Insert the adjuster for headlamp range control into the mounting frame and press in place.
- Push the securing tabs outwards until they interlock with the retaining tabs.
- Mount the plug connection.
- Install the bottom part of dash panel on the drivers' side.

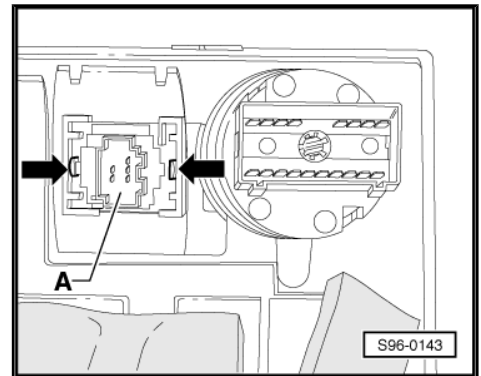

2.3 Removing and installing switches in centre console

Removing and installing:

- ◆ Parking aid switch
- ◆ The TCS/ESP switch
- ◆ Warning light for front passenger airbag deactivation
- ◆ Switch for further additional equipment
- ◆ Button for start-stop system
- ◆ Fuel selection switch - E395- (vehicles with gas drive as of CW 04/11)

Done in the same way for all switches/indicator lights and is only described for one switch/control light.

Removing

- Switch off the ignition and all electrical consumers!
- Carefully lever up the cover -1- using a cross-head screwdriver.
- Then lever out the relevant switch from the central console in the -direction of the arrow-.
- Pull out the switch and separate the plug connection.

Installing

- Mount the plug connection.
- Press switch into mount in the centre console and lock in place.
- Install the cover again.

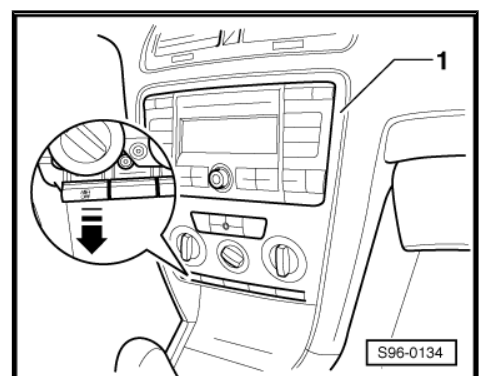

2.4 Removing and installing hazard warning lights button

Removing

- Switch off the ignition and all electrical consumers!

Protected by copyright. Copying for private or commercial purposes, in part or in whole, is not permitted unless authorised by ŠKODA AUTO A. S. ŠKODA AUTO A. S. does not guarantee or accept any liability with respect to the correctness of information in this document. Copyright by ŠKODA AUTO A. S. ©

- Then carefully lever out the switch from the centre flow vent -arrows-.
- Disconnect connector at switch.

Installing

The installation occurs in reverse order.

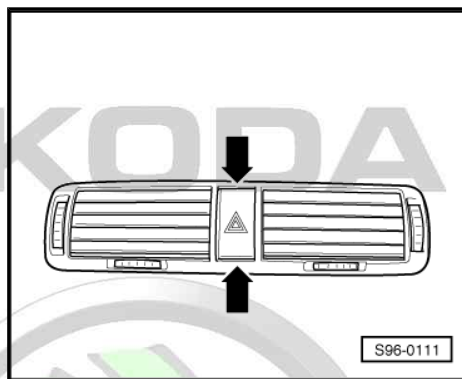

2.5 Removing and installing the mirror adjustment switch

Removing

- Switch off the ignition and all electrical consumers!
- Unclip cover for treble speaker -2-.
- Disconnect electrical plug connection -1-.

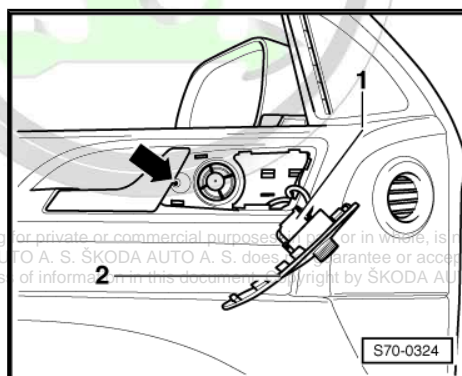

Protected by copyright. Copying for private or commercial purposes, in part or in whole, is not permitted unless authorised by ŠKODA AUTO A. S. ŠKODA AUTO A. S. does not guarantee or accept any liability of information in this document. Copyright by ŠKODA AUTO A. S.

- Remove operating unit -arrows-.

Installing

The installation occurs in reverse order.

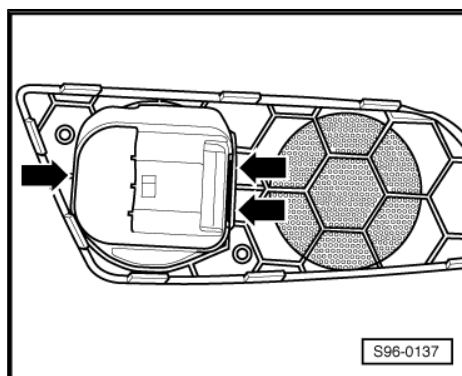

2.6 Removing and installing the switch for the power window lifter

- Switch off the ignition and all electrical consumers!

Removing and installing the switch for the power window lifter in the driver's door

- Unclip recessed handle -1-, pulling upwards -arrow-.
- Unplug the connector at the switch for the power window lifter.

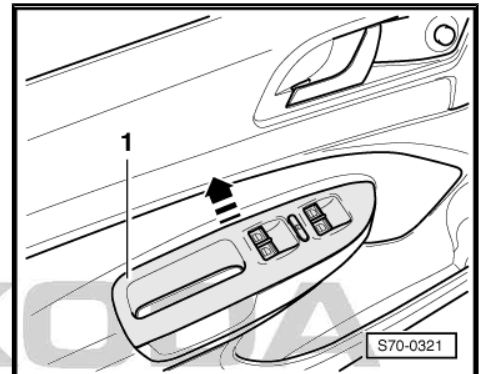

- Remove operating unit -arrows-.
- The installation occurs in reverse order.

Removing and installing the switch for the power window lifter in the front seat passenger's door

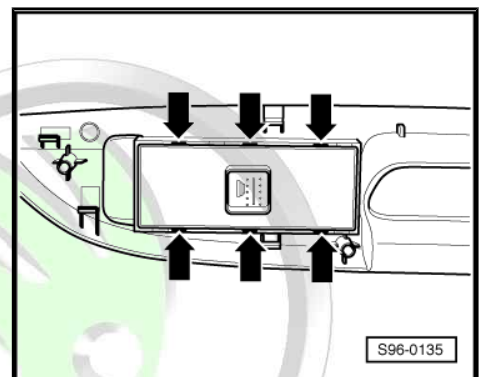

- Unclip cover for treble speaker -1-.
- Unplug the connector at the switch for the power window lifter.

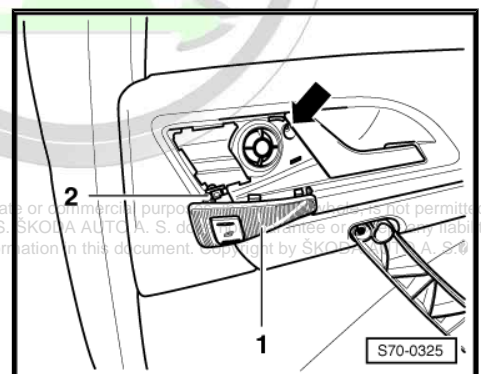

- Carefully unclip the switch -arrows-.
- The installation occurs in reverse order.

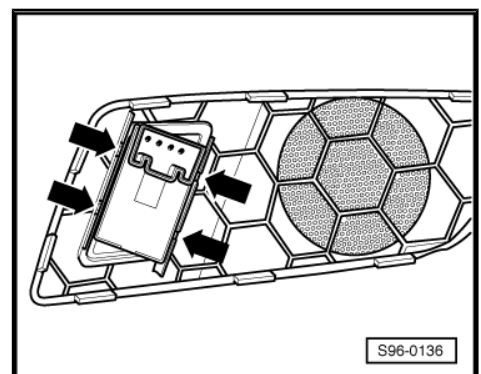

Protected by copyright. Copying for private or commercial purposes without permission is not permitted unless authorised by SKODA AUTO A. S. SKODA AUTO A. S. does not guarantee the availability of information in this document. Copyright by SKODA AUTO A. S.

2.7 Removing and installing interior monitoring deactivation switch -E 267- and deactivation button for vehicle inclination sender -E 360-



Note

According to the production year, the switch can have two or one button see ⇒ *Owner's manual Octavia II*. The mounting sequence is identical for both types.

Removing

- Switch off the ignition and all electrical consumers!
- Remove the trim panel of pillar B on the driver's side -1- ⇒ Body work; Rep. gr. 70 .
- Disconnect connector at switch.
- Press the lateral retaining clamp of the button using a cross-head screwdriver and remove the button -2- from the trim panel.

Installing

The installation occurs in reverse order.

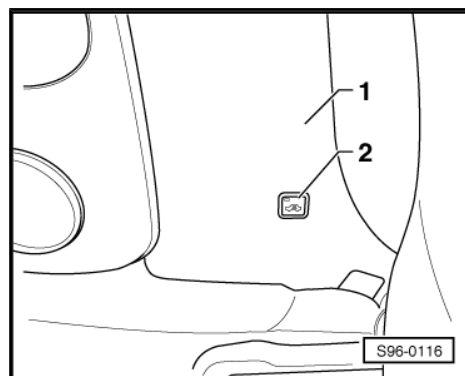

2.8 Removing and installing switch for inside actuation of the central locking

Removing

- Switch off the ignition and all electrical consumers!
- Remove the centre console -2- ⇒ Body Work; Rep. gr. 68 .
- Disconnect the plug connection at door contact switch.
- Press the lateral retaining clamps of the switch using a cross-head screwdriver and remove the switch -1- from the centre console.

Installing

The installation occurs in reverse order.

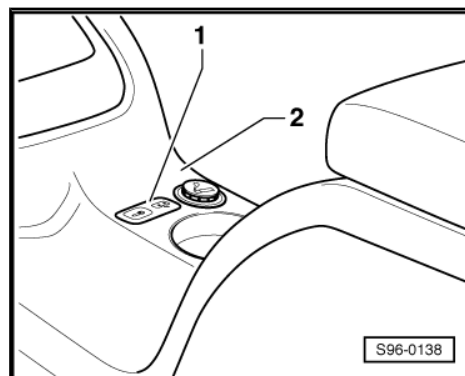

2.9 Removing and installing the fuel selector switch - E395- (petrol/gas)



Note

As of CW 04.2011, the switch is located in the centre console together with the other switches see ⇒ [page 163](#) .

Removing

- Switch off the ignition and all electrical consumers!



- Slacken shift lever collar => gearbox; Rep. gr. 34 .
- Press -arrow- the switch -1- out of the socket -2- using a suitable short screwdriver or a rod (with a blunt edge).
- Disconnect the plug from the switch.

Installing

- Fit on plug and press the switch -1- again into its socket -2-.
- Clip in the shift lever collar again.

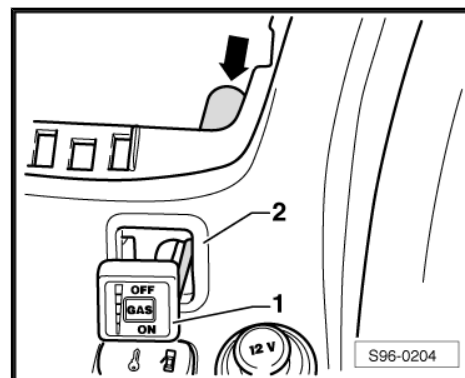

2.10 Removing and installing the rear seat heating switch

Removing

- Switch off the ignition and all electrical consumers!
- Open rear ashtray -2-.
- Grab the switch carrier -1- from below -arrow- and carefully unclip it.
- Disconnect the plug connections.

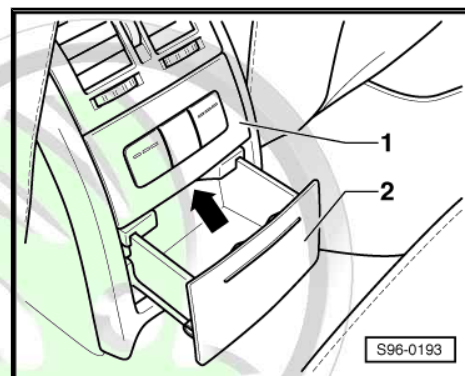

- Unclip the switch -arrows- using a small cross-head screwdriver and push it out.

Installing

The installation occurs in reverse order.

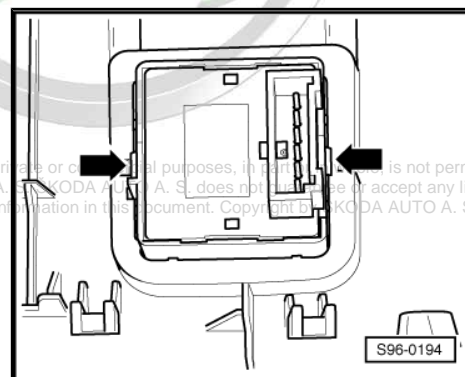

Protected by copyright. Copying for private or internal purposes, in particular for personal use, is not permitted unless authorised by ŠKODA AUTO A.S. ŠKODA AUTO A.S. does not guarantee or accept any liability with respect to the correctness of information in this document. Copyright © ŠKODA AUTO A.S.



3 Components in the luggage compartment and tailgate

⇒ [“3.1 Removing and installing the switch for the luggage compartment lighting”, page 168](#)

⇒ [“3.2 Removing and installing the motor for unlocking the tailgate”, page 168](#)

⇒ [“3.3 Removing and installing the tailgate release switch”, page 168](#)

3.1 Removing and installing the switch for the luggage compartment lighting

The switch for the luggage compartment lighting is located in the tailgate lock and cannot be replaced individually.

Remove and install the tailgate lock ⇒ Body Work; Rep. gr. 55 .

3.2 Removing and installing the motor for unlocking the tailgate

⇒ Body Work; Rep. gr. 55

3.3 Removing and installing the tailgate release switch

⇒ Body Work; Rep. gr. 55

ŠKODA



4 Horn

The horn is located (except vehicles for India) behind the fog lights at the left and right (dual tone horn), or at the left (simple horn).

On vehicles for India, the horn is located at the front flap lock.



Caution

The tone pitch of the horn is set at the factory. It is prohibited to change this setting or to adjust the control screw!

If it is noticed that a screw is adjusted, the guarantee is no longer valid.

⇒ [“4.1 Removing and installing horn”, page 169](#)

4.1 Removing and installing horn

Remove (except vehicles for India)

- Switch off the ignition and all electrical consumers!

Octavia RS and Scout:

- Remove the front wheelhouse liner ⇒ Body Work; Rep. gr. 66 .

Other vehicles:

- Unclip the trim panel at the front left or right on the bumper.
- Remove fog light ⇒ [page 125](#) .

All vehicles:

- Unscrew fixing screw (20 Nm) -arrow- and remove horn with holder towards the front.
- Disconnect electrical plug connection.
- If necessary unscrew nut (12 Nm) and remove holder from horn.

Remove - vehicles for India

On vehicles for India, the horn is located at the front flap lock.

- Open front flap.

Protected by copyright. Copying for private or commercial purposes, in part or in whole, is not permitted unless authorised by ŠKODA AUTO A. S. ŠKODA AUTO A. S. does not guarantee or accept any liability with respect to the correctness of information in this document. Copyright by ŠKODA AUTO A. S.

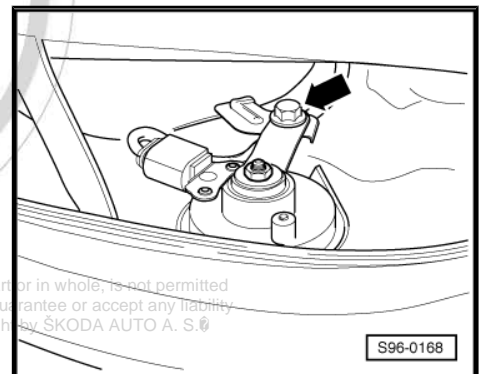

- Screw out the fixing screws -1- (16 Nm).
- Disconnect plug.
- If necessary unscrew nut (12 Nm) and remove holder from horn.

Installing

The installation occurs in reverse order.

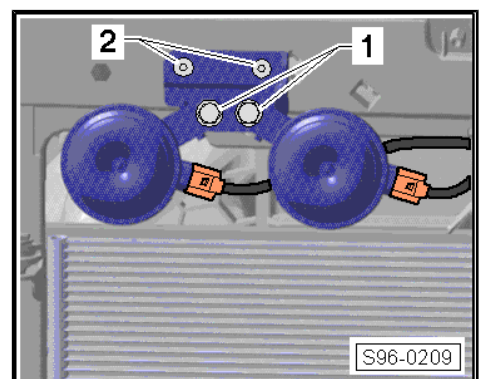



5 Anti-theft warning system

⇒ [“5.1 General points”, page 170](#)

⇒ [“5.2 Removing and installing the horn H12”, page 170](#)

⇒ [“5.3 Removing and installing interior monitoring sensor G273 and vehicle inclination sender G384”, page 171](#)

⇒ [“5.4 Removing and installing interior monitoring deactivation switch E267 and deactivation button for vehicle inclination sender E360”, page 171](#)

5.1 General points

The functions of the anti-theft warning system are integrated:

- Vehicles up to MY 2008 - in the Convenience system central control unit - J393-
- Vehicles as of MY 2009 (Facelift) - in the vehicle voltage control unit - J519-

After replacing the Convenience system central control unit - J393- or the vehicle voltage control unit - J519- , the anti-theft warning system must be adapted with the ⇒ Vehicle diagnostic tester.

Further information and description of function:

- ◆ ⇒ Owner's manual Octavia II
- ◆ ⇒ Self-study programme No. 54 ; Škoda Octavia; Electrical Components

Fault recognition and fault display

The anti-theft warning system is equipped with self-diagnosis, which facilitates the troubleshooting.

For fault finding use the ⇒ Vehicle diagnostic tester in the function “Targeted fault finding”.



Note

- ◆ *After triggering the anti-theft warning system, the alarm source which is stored in the Convenience system central control unit - J393- or the vehicle voltage control unit - J519- can be output. To determine the alarm source, use the ⇒ Vehicle diagnostic tester in the function “Targeted functions” - “Measured value blocks”.*
- ◆ *Before assembly, the vehicle must be unlocked with the release button of the radio control receiver.*

5.2 Removing and installing the horn - H12-



Note

The horn - H12- has an emergency battery which cannot be replaced as a separate item.

Removing

- Switch off the ignition and all electrical consumers! The vehicle must not be locked via the radio control receiver of the central locking.

ŠKODA

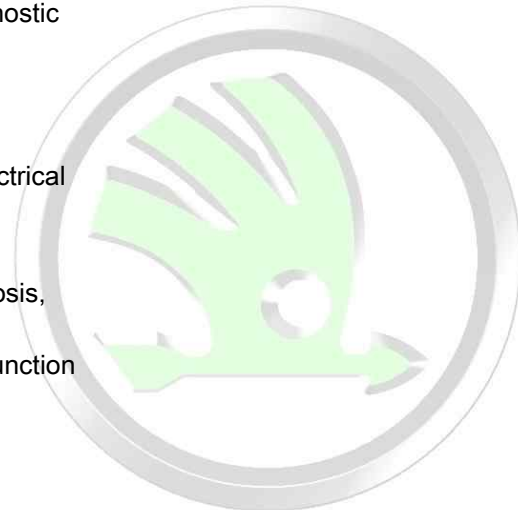

Copying for private or commercial purposes, in part or in whole, is not permitted. ŠKODA AUTO A. S. ŠKODA AUTO A. S. does not guarantee or accept any liability for the correctness of information in this document. Copyright by ŠKODA AUTO A. S. ©

- Remove the front right wheelhouse liner ⇒ Body Work; Rep. gr. 66 .
- Unscrew nuts -arrows B-.
- Bore out rivet head or pull-off screw -arrow A-.
- Disconnect plug.
- Remove horn from holder.

Installing

Installation is carried out in the reverse order. When installing, observe the following:



Note

- ◆ Any damage to the paintwork during drilling must be repaired by a specialist.
- ◆ Replace drilled pull-off screws/riveted nuts with a new part ⇒ *Electronic Catalogue of Original Parts* .

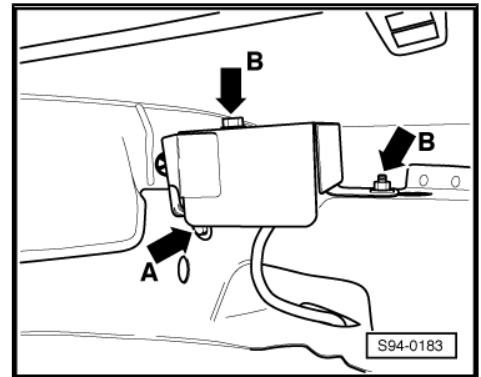

5.3 Removing and installing interior monitoring sensor - G273- and vehicle inclination sender - G384-

Removing

The sensors are located in the cover of the moulded headliner.

- Switch off the ignition and all electrical consumers! The vehicle must not be locked via the radio control receiver of the central locking.
- Remove the cover -2- using the disassembly wedge - 3409- .

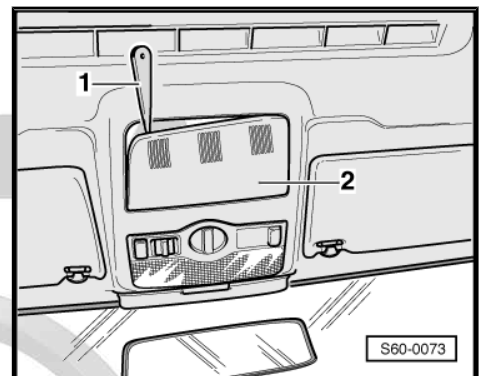

- Release locking tabs -arrows-.
- Remove the sensors -1- from the cover -2-.

Installing

Installation is carried out in the reverse order. When installing, observe the following:

- When replacing the part with number "1Z0 951 171 A" with the part with number "5J0 951 172" use the ⇒ Vehicle diagnostic tester to perform the parameterisation of the functions of the onboard control unit - J519- .

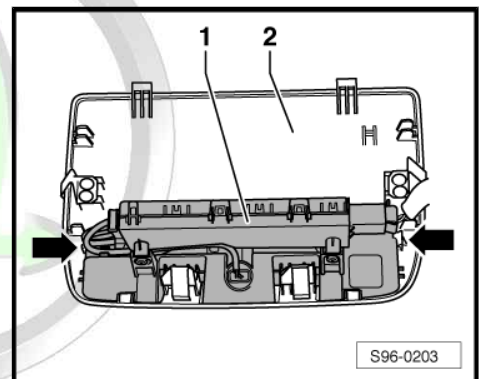

5.4 Removing and installing interior monitoring deactivation switch - E267- and

Commercial purposes, in part or in whole, is not permitted unless authorised by SKODA AUTO A. S. SKODA AUTO A. S. does not guarantee or accept any liability for the content of this document. Copyright by SKODA AUTO A. S. ©



deactivation button for vehicle inclination sender - E360-

Removing and installing interior monitoring deactivation switch - E267- and deactivation button for vehicle inclination sender - E360- ⇒ [page 166](#) .

ŠKODA



Protected by copyright. Copying for private or commercial purposes, in part or in whole, is not permitted unless authorised by ŠKODA AUTO A. S. ŠKODA AUTO A. S. does not guarantee or accept any liability with respect to the correctness of information in this document. Copyright by ŠKODA AUTO A. S. ©

6 12 V power sockets / cigarette lighter

⇒ [“6.1 Removing and installing the 12 V power socket/cigarette lighter in the centre console”](#), page 173

⇒ [“6.2 Removing and installing luggage compartment 12 V socket - Octavia Combi”](#), page 174

6.1 Removing and installing the 12 V power socket/cigarette lighter in the centre console

Special tools and workshop equipment required

- ◆ Release tool - T40148-

Removing



Note

For purposes of clearer presentation, the socket is shown as partly removed in the figure.

- Switch off the ignition and all electrical consumers!
- Insert the extractor -T40148- in such a way that the retaining tabs lock into the recesses in the socket housing -arrow- at the extractor -2-.

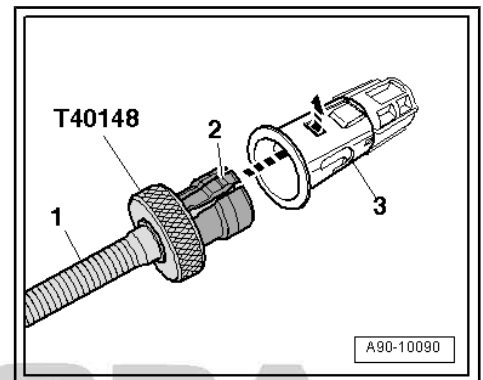

- After locking the retaining tabs, position the clamp -2- and turn with the knurled nut -1- -arrow-, until the socket -3- is completely pulled out of the centre console -4-.



Note

Pay attention to the wiring length when pulling out the socket.

- Disconnect plug.

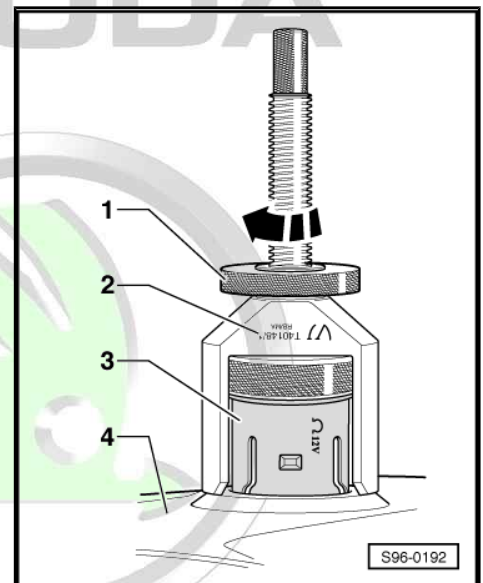



- Unscrew the knurled nut and push out the support bracket -1-.
- The retaining tabs -2- are unlocked by pressing on the spindle of the extractor and by turning -arrow- the knurled wheel -4-.
- Push the extractor out of the socket housing -3-.



Note

The retaining springs of the socket are pressed apart by inserting the extractor and the holding torque is reduced.

- Carefully press together again the retaining springs of the socket -arrow-, in order to increase the holding torque.

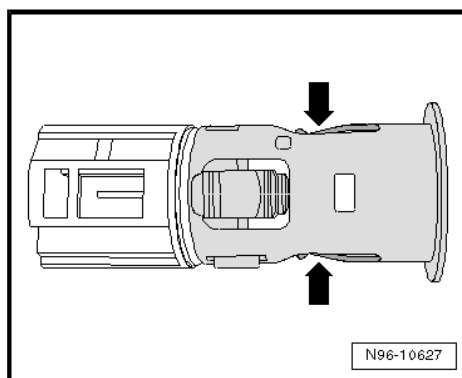
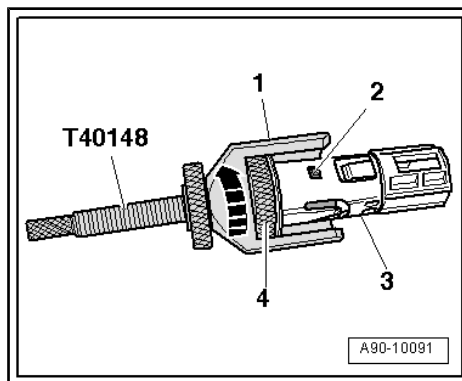

- Slacken the tensioning sleeve of the socket -1- out of the catch peg -2-, tilt out the tensioning sleeve -arrow- and remove it.

Installing

- Insert the tensioning sleeve of the socket into the centre console until it clicks audibly into place.
- Place the connector onto the socket.
- Insert power socket into the tensioning sleeve up to the stop.
- Check the cigarette lighter for proper function (after the pre-heating process, it remains in the removal position and is not hurled into the vehicle interior).

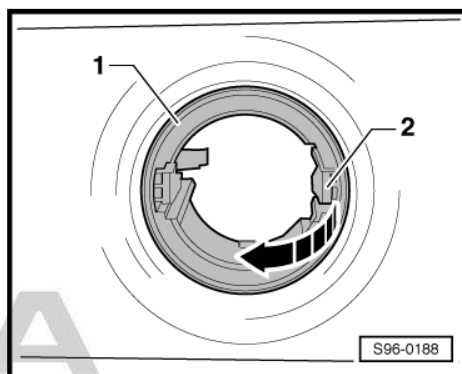

6.2 Removing and installing luggage compartment 12 V socket - Octavia Combi

Removing

- Remove right side trim panel in luggage compartment => Body Work; Rep. gr. 70 .
- Disconnect electrical plug connection -1-.
- Unscrew nut -5-.
- Pull power socket -2- with socket -3- out of the trim panel -4-.

Installing

The installation occurs in reverse order.

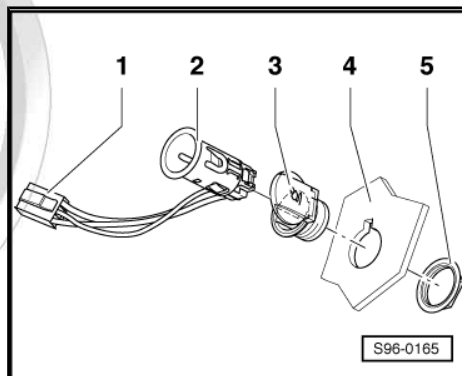

7 Immobiliser

The model Octavia II features the immobiliser of the fourth generation. An essential component part of the immobiliser of the fourth generation is a central database, in which all theft-related data of the control units involved are stored. As of 2007, it is no longer possible to adapt the immobiliser control units according to the engine without online connection to this database.

In vehicles manufactured up to MY 2006, the immobiliser control units can also be adapted (if no PIN for the immobiliser is available) via an online connection ⇒ Vehicle diagnostic tester

- ◆ A PIN code request of the immobiliser components by fax or temporary activation of the components is not possible.
- ◆ All the components of the immobiliser must be initialised online (not necessary for vehicles manufactured up to MY 2006).
- ◆ In Škoda vehicles it is no longer possible to adapt the components of other corporate brands.

Vehicles manufactured as of MY 2007, which must be coded online (depending on the engine):

- ◆ All - even re-ordered - ignition keys are already precoded at the factory for a specific vehicle and can only be initialised for this vehicle.
- ◆ When re-ordering ignition keys, the relevant vehicle identification number must be provided.

System test result (online connection) ⇒ [page 177](#) .

Immobiliser components:

- ◆ Immobiliser control unit - J362- ⇒ [page 176](#)
- ◆ Engine control unit - J623- diesel engines ⇒ Engine; Rep. gr. 23 , or petrol engines ⇒ Engine; Rep. gr. 24
- ◆ Ignition key ⇒ [page 176](#)

Further information and description of the individual components ⇒ Self-study programme No. 87 ; Immobilisers in Škoda vehicles .

New identity when changing all the immobiliser components ⇒ [page 177](#) .

Functions of the immobiliser control unit - J362- :

- ◆ Communication between all the immobiliser components
- ◆ Encryption of data between the control units involved

Fault recognition and fault display

The immobiliser is equipped with self-diagnosis, which facilitates the fault finding.

For fault finding, use the ⇒ Vehicle diagnostic tester in the mode "Targeted fault finding".

⇒ ["7.1 Immobiliser control unit J362 ", page 176](#)

⇒ ["7.2 Ignition key", page 176](#)

⇒ ["7.3 New identity when changing all the components", page 177](#)

⇒ ["7.4 System test result \(online connection\)", page 177](#)



7.1 Immobiliser control unit - J362-

The immobiliser control unit - J362- is integrated in the dash panel insert. If the control unit is defective, the complete dash panel insert must be replaced.

Adapt immobiliser control unit - J362-

- Connect the ⇒ Vehicle diagnostic tester.
- In the ⇒ Vehicle diagnostic tester, select the operating mode "Targeted fault-finding".
- Select the "Selected Functions/Components" and subsequently the following menu points using the button "Skip":
 - ◆ Body
 - ◆ Electrical system
 - ◆ 01 – Self-diagnosable systems
 - ◆ Immobiliser
 - ◆ Operation
 - ◆ Adjust dash panel insert

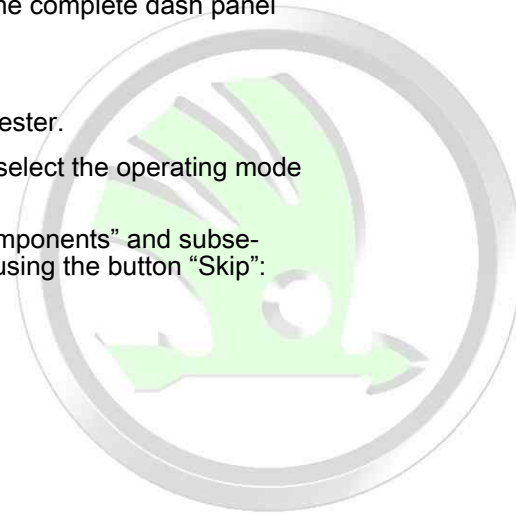

Protected by copyright. Copying for private or commercial purposes, in part or in whole, is not permitted unless authorised by ŠKODA AUTO A. S. ŠKODA AUTO A. S. does not guarantee or accept any liability with respect to the correctness of information in this document. Copyright by ŠKODA AUTO A. S. ©

7.2 Ignition key

Vehicles manufactured as of MY 2007, which must be coded on-line (depending on the engine) - all - even re-ordered - ignition keys are already precoded at the factory for a specific vehicle and can only be initialised for this vehicle. When re-ordering ignition keys, the relevant vehicle identification number must be provided and subsequently the new keys must be adapted to the immobiliser control unit - J362- .



Note

Before replacing the lock set or the control units, the function "New identity when changing all the components" must be retrieved.

⇒ ["7.2.1 Adapting and checking the ignition key", page 176](#)

7.2.1 Adapting and checking the ignition key



Note

If new or additional ignition keys are required, they must be adapted to the immobiliser control unit.

Adapt the ignition key to the immobiliser control unit - J362- or check:

- Connect the ⇒ Vehicle diagnostic tester.
- In the ⇒ Vehicle diagnostic tester, select the operating mode "Targeted fault-finding".
- Select the "Selected Functions/Components" and subsequently the following menu points using the button "Skip":
 - ◆ Body
 - ◆ Electrical system
 - ◆ 01 – Self-diagnosable systems
 - ◆ Immobiliser

- ◆ Operation
- ◆ Adapt and check the ignition key

7.3 New identity when changing all the components

All necessary steps required for the new installation of all the immobiliser components are carried out with this programme.

- Connect the ⇒ Vehicle diagnostic tester.
- In the ⇒ Vehicle diagnostic tester, select the operating mode “Targeted fault-finding”.
- Select the “Selected Functions/Components” and subsequently the following menu points using the button “Skip”:

- ◆ Body
- ◆ Electrical system
- ◆ 01 – Self-diagnosable systems
- ◆ Immobiliser
- ◆ Operation
- ◆ New identity

7.4 System test result (online connection)

The following steps are carried out with this test programme:

- ◆ System test for the online connection
- ◆ Verification of user authorisation
- ◆ Test the correct cable connection to the Škoda database

The precondition for this is the online connection (network connection) of the tester.

- Connect the ⇒ Vehicle diagnostic tester.
- In the ⇒ Vehicle diagnostic tester, select the operating mode “Targeted fault-finding”.
- Select the “Selected Functions/Components” and subsequently the following menu points using the button “Skip”:
- ◆ Body
- ◆ Electrical system
- ◆ 01 – Self-diagnosable systems
- ◆ Immobiliser
- ◆ Operation
- ◆ Online system test

ŠKODA

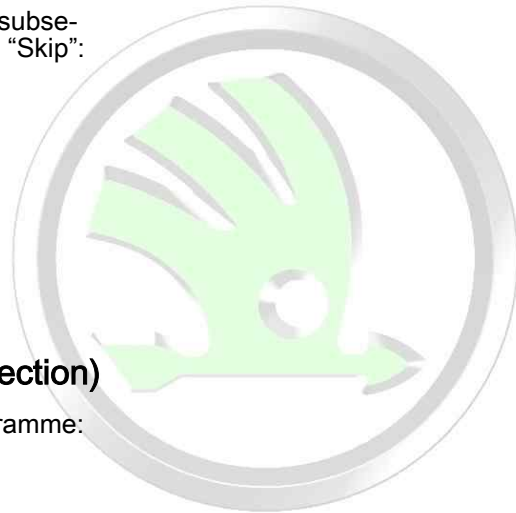

Copying for private or commercial purposes, in part or in whole, is not permitted without the written permission of ŠKODA AUTO A. S. ŠKODA AUTO A. S. does not guarantee or accept any liability with respect to the correctness of information in this document. Copyright by ŠKODA AUTO A. S.



97 – Wiring

1 Fuse holder and relay carrier



Note

- ◆ *The exact assignment of the fuse holder and relay carrier can be taken from the valid current flow diagram ⇒ Current flow diagrams, Electrical fault finding and Fitting locations.*
- ◆ *Further information and description ⇒ Self-study programme No. 54 ; Skoda Octavia II introduction of vehicle .*

⇒ [“1.1 Removing and installing fuse holder from dash panel”](#),
page 178

⇒ [“1.2 Removing and installing the relay carrier under the vehicle voltage control unit J519 - vehicles as of MY 09”](#), page 179

⇒ [“1.3 Removing and installing additional relay carrier above the onboard supply control unit”](#), page 180

⇒ [“1.4 Removing and installing the E-box \(relay and fuse carrier in the engine compartment\)”](#), page 182

1.1 Removing and installing fuse holder from dash panel

Removing

- Disconnect battery earth strap ⇒ [page 2](#) .
- Insert the screwdriver in the recess -2-, lever out the side cover -1- -arrow- and remove from the dash panel.
- Remove lower part of the dash panel insert on the driver's side ⇒ Body; Rep. gr. 70 Work.

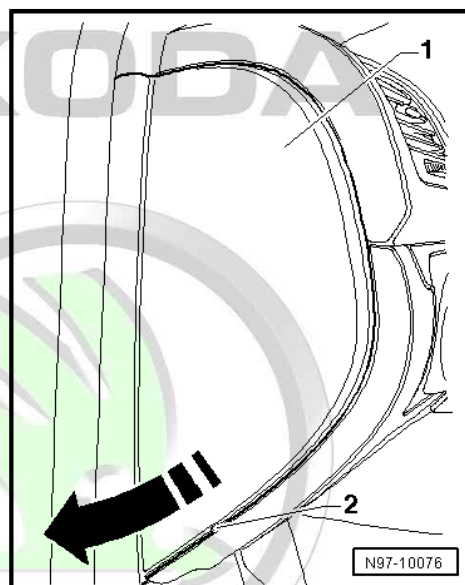

- Release both fixing screws (2,5 Nm) -arrows- and take out the fuse holder -1- towards the inside.

Installing

Installation is carried out in the reverse order. When installing, observe the following:

- Follow the work procedure when connecting the battery ⇒ [page 2](#) .

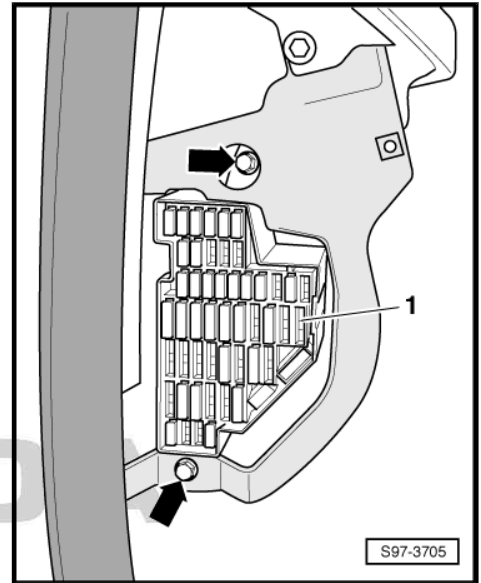

1.2 Removing and installing the relay carrier under the vehicle voltage control unit - J519- - vehicles as of MY 09



Note

- ◆ *The assignment of the relay carrier depends upon the vehicle equipment.*
- ◆ *Exact assignment of the relay carrier ⇒ Current flow diagrams, Electrical fault finding and Fitting locations.*

Removing

- Disconnect battery earth strap ⇒ [page 2](#) .
- Remove lower part of the dash panel insert on the driver's side ⇒ Body; Rep. gr. 70 Work.
- Press together the catch pegs -arrows A- and push the relay carrier -1- with relays out of the brackets at the vehicle voltage control unit -2-.
- Take the relay out of the relay carrier.

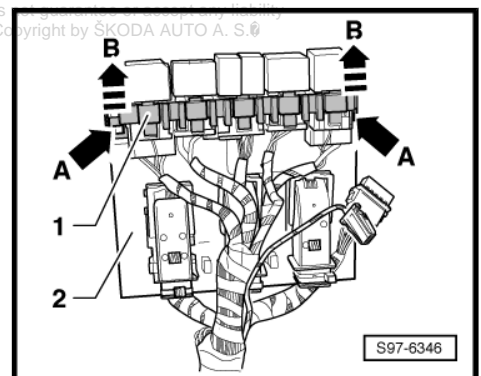



- Press off the catch pegs -arrows- and press the plug connections out of the relay carrier.

Installing

Installation is carried out in the reverse order. When installing, observe the following:

- Follow the work procedure when connecting the battery => [page 2](#) .

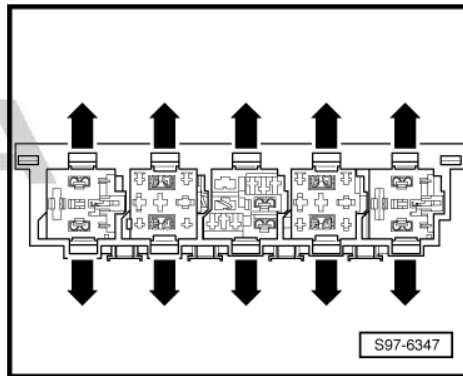

1.3 Removing and installing additional relay carrier above the onboard supply control unit



Note

- ◆ *The assignment of the relay carrier depends upon the vehicle equipment.*
- ◆ *Exact assignment of the relay carrier => Current flow diagrams, Electrical fault finding and Fitting locations.*

Removing

Protected by copyright. Copying for private or commercial purposes, in part or in whole, is not permitted unless authorised by ŠKODA AUTO A. S. ŠKODA AUTO A. S. does not guarantee or accept any liability for errors or the correctness of information in this document. Copyright by ŠKODA AUTO A. S. ©

- Disconnect battery earth strap => [page 2](#) .
- Remove lower part of the dash panel insert on the driver's side => Body; Rep. gr. 70 Work.
- Pull the relay out of the relay carrier above the vehicle voltage control unit.
- Slacken the plug connections -1- out of the catch pegs -arrows- and press out of the relay carrier.

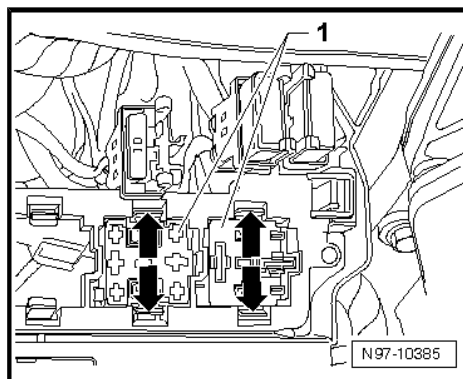

- Release the holder -arrow A- and remove together with the fuse -arrow B- from the relay carrier.

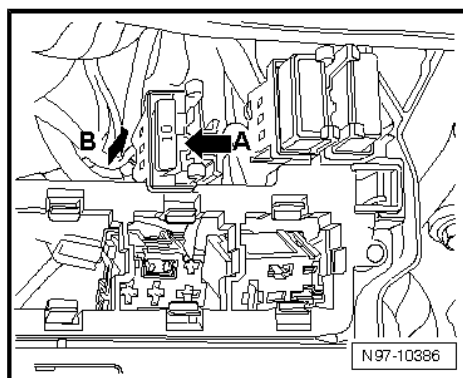

- Unlatch the clamps -arrows- and remove the thermal fuses -1- from the support.

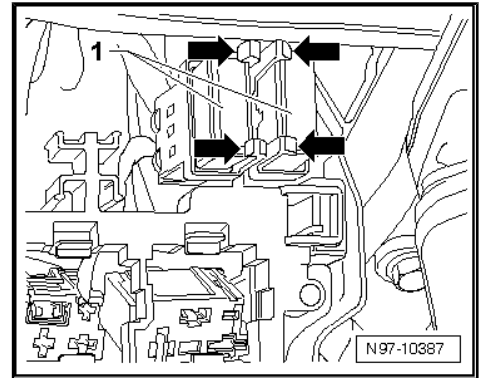

- Release the stops -1- and -2- in direction of arrow -A- and -B- and remove the support in direction of arrow -C-.

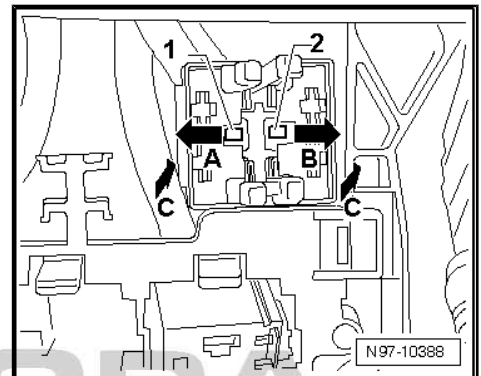

- Unlatch the fuse -1- -arrow- and remove the holder.

Installing

Installation is carried out in the reverse order. When installing, observe the following:

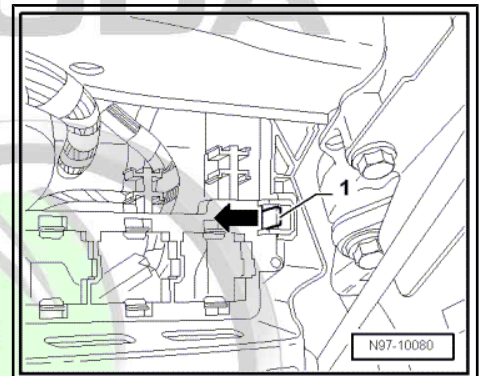

- Insert the relay carrier -2- into the guide -1- and then lock it.
- Follow the work procedure when connecting the battery => [page 2](#) .

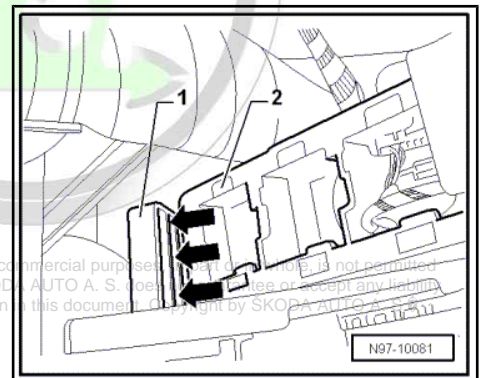

Protected by copyright. Copying for private or commercial purposes without the written permission of ŠKODA AUTO A. S. is not permitted unless authorised by ŠKODA AUTO A. S. ŠKODA AUTO A. S. does not accept any liability with respect to the correctness of information in this document. Copyright by ŠKODA AUTO A. S.

1.4 Removing and installing the E-box (relay and fuse carrier in the engine compartment)



Note

- ◆ *The number of plug connections, fuses, relays and connections can vary depending on the vehicle equipment.*
- ◆ *The exact assignment of the plugs, fuses, relays and connections ⇒ Current flow diagrams, Electrical fault finding and Fitting locations.*

⇒ ["1.4.1 Vehicles up to MY 05", page 182](#)

⇒ ["1.4.2 Vehicles as of MY 06", page 183](#)

1.4.1 Vehicles up to MY 05

Removing

- Remove air filter ⇒ Engine; Rep. gr. 24 .
- Remove the battery ⇒ [page 5](#) .
- Pull out relay carrier in -direction of arrow- below the E-box.
- Remove cover from the E-box.

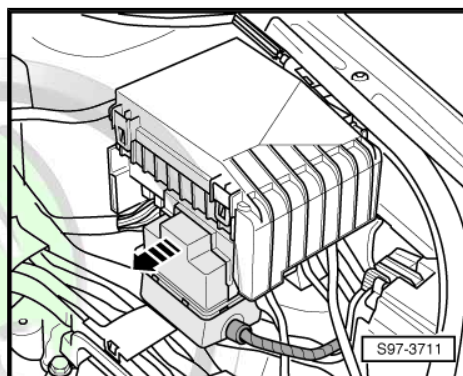

- Unscrew the nuts -1-.
- M5 - 4.5 Nm
- M6 - 6 Nm
- Open the covers -2- of the cable guide on the E box -1- -arrows-.
- Remove the cables from the connecting bolts.
- Remove the cables from the guides.

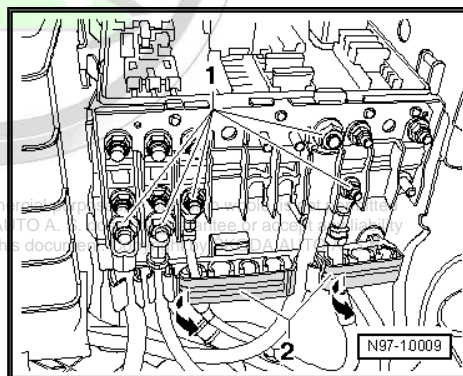

- Unscrew the plug -arrow-.
- Take relay and fuse carrier out of the E-box.

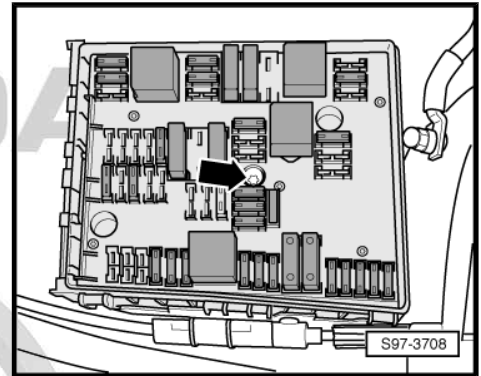

- Unlock the 26-pin plug -1- and the 40-pin plug -2- and remove from the E-box.

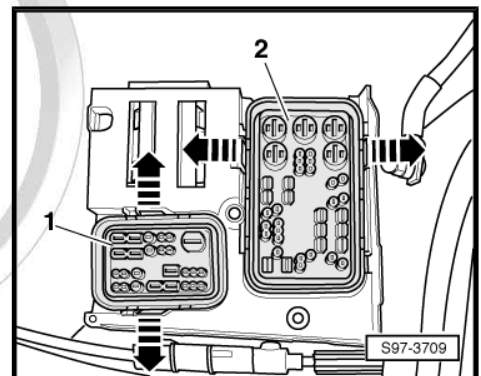

- Unscrew nuts -1- and -2-.
- Remove the E box holder -3-.

Protected by copyright. Copying for private or commercial purposes, in part or in whole, is not permitted unless authorised by ŠKODA AUTO A. S. ŠKODA AUTO A. S. does not guarantee or accept any liability with respect to the correctness of information in this document. Copyright by ŠKODA AUTO A. S. ©

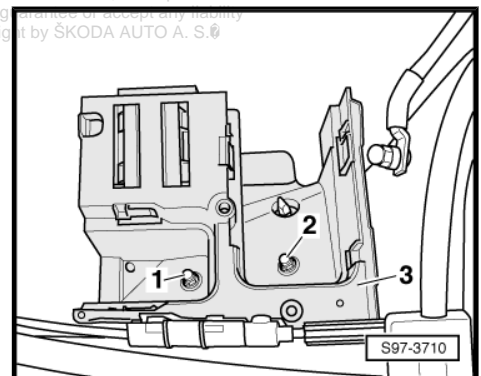

Installing

Installation is carried out in the reverse order. When installing, observe the following:

- Make sure the upper trim panel correctly locks into position.
- Follow the work procedure when connecting the battery ⇒ [page 2](#) .

1.4.2 Vehicles as of MY 06

Removing

- Remove air filter ⇒ Engine; Rep. gr. 24 .
- Remove the battery ⇒ [page 5](#) .
- Release cover from the E-box -arrows-.

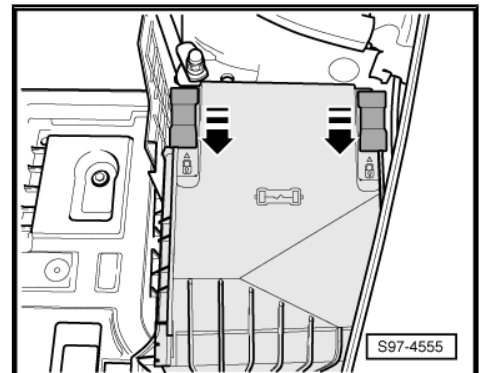



- Remove cover from the E-box -arrow-.

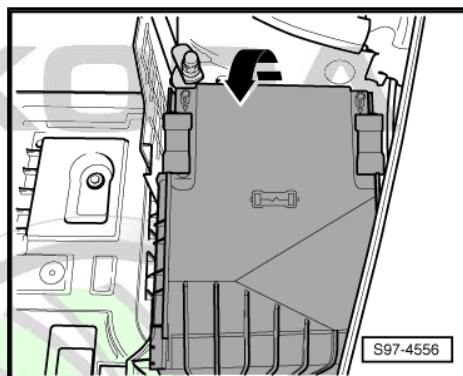

- Unscrew the nuts -1-.
- M5 - 4.5 Nm
- M6 - 6 Nm
- Open the covers -2- of the cable guide on the E box -1- -arrows-.
- Remove the cables from the connecting bolts.
- Remove the cables from the guides.

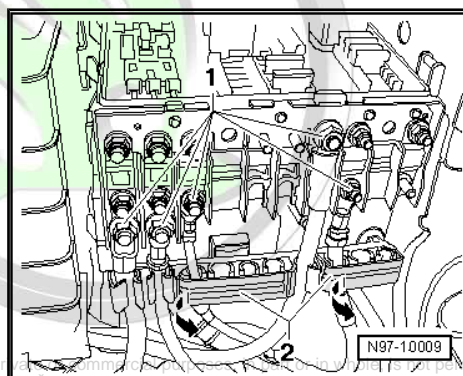

- Release central screw -arrow- (9 Nm).



Note

By screwing out the central fixing screw -arrow-, the E-box -1- is pressed towards the top by the E-box holder.

- Remove the E-box -1- from the holder upwards.

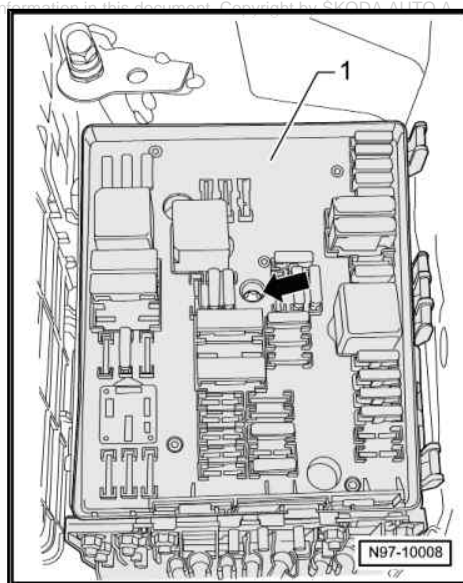

Protected by copyright. Copying for private use only. ŠKODA AUTO A.S. does not guarantee the accuracy, reliability or completeness of the information contained in this document. ŠKODA AUTO A.S. is not liable for any damage or loss resulting from the use of this document.

- Press the catch pegs apart from one another at the E-box holder -arrows B- and push the flat contact housing -1- out of the E-box holder to the side -arrow A-.
- Unlock the flat contact housing -2- (if present) -arrows C- and push it out of the E box holder -arrow D-.

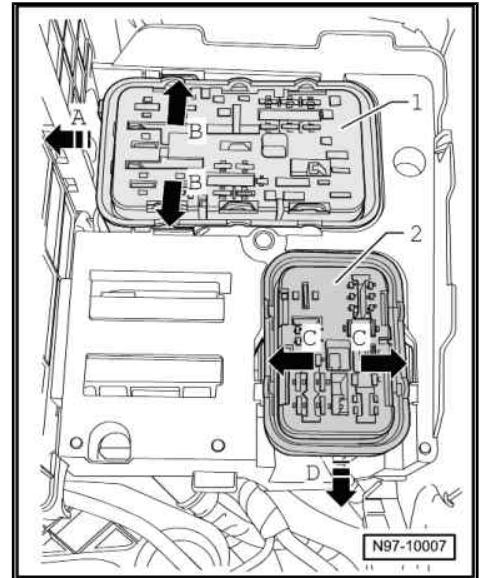

- Screw out fixing nuts -arrows- (9 Nm) and take out the E-box holder -1-.

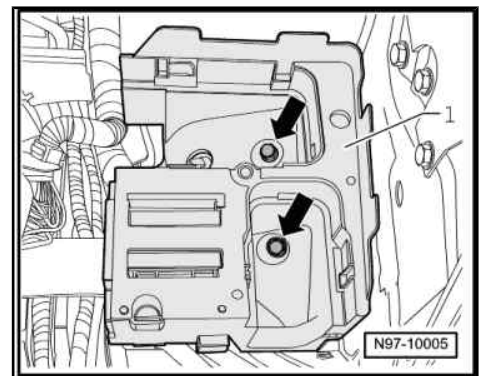

- Vehicles with diesel engine - press additional relay carrier -1- out of the E box holder -2-.

Installing

Installation is carried out in the reverse order. When installing, observe the following:

Note

On vehicles where there is a label on the cover of the E box with a note indicating the required change of the multi-pin fuse (mounted as of 11.08), this fuse must be replaced when loosening the nut -1-.

- Make sure the upper trim panel correctly locks into position.
- Follow the work procedure when connecting the battery
⇒ [page 2](#) .

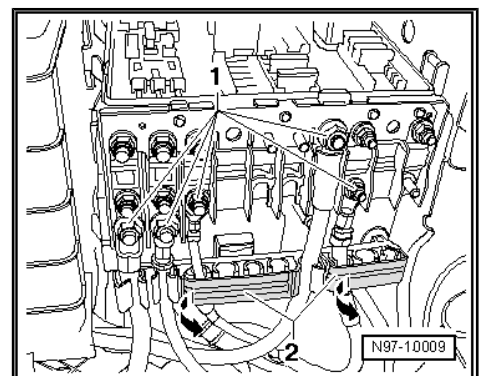
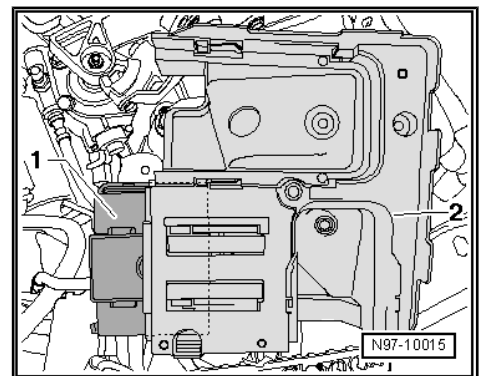

Protected by copyright. Copying for private or commercial purposes, in part or in whole, is not permitted unless authorised by ŠKODA AUTO A. S. ŠKODA AUTO A. S. does not guarantee or accept any liability with respect to the correctness of information in this document. Copyright by ŠKODA AUTO A. S. ©

2 Control units

⇒ [“2.1 Onboard supply control unit J519”](#), page 186

⇒ [“2.2 Central control unit for convenience system J393”](#), page 189

⇒ [“2.3 Data bus diagnostic interface Gateway J533”](#), page 191

2.1 Onboard supply control unit - J519-

General description

The vehicle voltage control unit - J519- communicates with other control units via the data buses CAN bus, its own data buses LIN bus and data interface GATEWAY.

As of MY 2009 (Facelift), this control unit also regulates the convenience functions of the vehicle (for vehicles up to MY 2008, the convenience functions were regulated via the Convenience system central control unit - J393- , which is no longer fitted as of MY 2009).

If the vehicle voltage control unit - J519- is replaced, the new control unit must be coded ⇒ [page 187](#) .

After the replacement (depending on equipment) the functions of the control unit such as “remote control for central locking”, “anti-theft warning system”, etc. must be adapted see ⇒ [page 188](#) .

Other information:

- ⇒ Self-study programme No. 54 ; Škoda Octavia; Electrical Components
- ⇒ Self-study programme No. 66 ; Škoda Superb II: Vehicle introduction part. II (as of MY 2009, the vehicle voltage control unit is similar as for Superb II)
- ⇒ Vehicle diagnostic tester
- ⇒ Current flow diagrams, Electrical fault finding and Fitting locations

⇒ [“2.1.1 Removing and installing the vehicle voltage control unit J519”](#), page 186

⇒ [“2.1.2 Coding the vehicle voltage control unit J519”](#), page 187

⇒ [“2.1.3 Adapting the functions of the vehicle voltage control unit J519”](#), page 188

⇒ [“2.1.4 Actuator diagnosis of the vehicle voltage control unit J519”](#), page 189

Fault recognition and fault display

The onboard supply control unit - J519- is equipped with self-diagnosis, which facilitates fault finding.

For fault finding use the ⇒ Vehicle diagnostic tester in the function “Targeted fault finding”

2.1.1 Removing and installing the vehicle voltage control unit - J519-

Removing

- Disconnect battery earth strap ⇒ [page 2](#) .
- Remove lower part of the dash panel insert on the driver's side ⇒ Body; Rep. gr. 70 Work.

Vehicles up to MY 08

- Release catch pegs -arrows- and remove the control unit -1- from the bracket -2- downwards.

i Note

All plug connections are separated for purposes of clear presentation.

- Unlock the central locking system and then disconnect all the plugs.

Vehicles as of MY 09

- Unclip the relay carrier under the vehicle voltage control unit and unhook towards the bottom ⇒ [page 179](#) .
- To disconnect the plugs,, successively press together the catches on the plug connections -1- and disconnect the connectors from the control unit by swivelling out the bracket -arrow-.

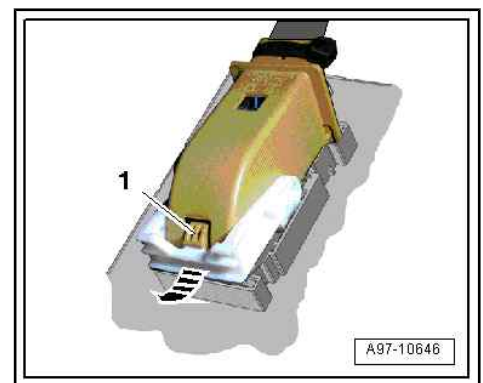
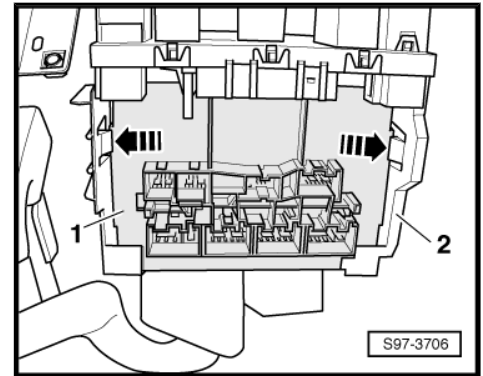

- Unhook the pulled-out connector -2- towards the bottom.
- Press together the catches -arrows A-, slightly swivel out the control unit -arrow B- and push out of the bearing in the bracket -arrow C-.

Installing

Installation is carried out in the reverse order. When installing, observe the following:

i Note

- ◆ If the vehicle voltage control unit - J519- is replaced, the new control unit must be coded ⇒ [page 187](#) .
- ◆ After the replacement (depending on equipment) the functions of the control unit such as "remote control for central locking", "anti-theft warning system", etc. must be adapted see ⇒ [page 188](#) .

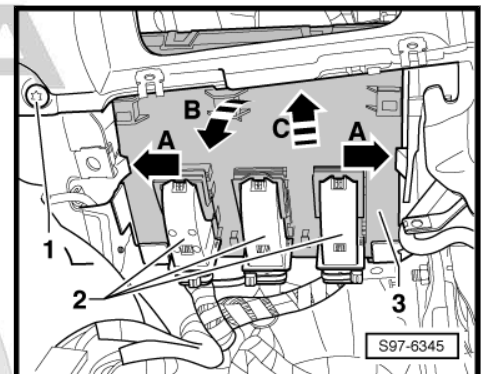

2.1.2 Coding the vehicle voltage control unit - J519-

i Note

Protected by copyright. Copying for private or commercial purposes, in part or in whole, is not permitted unless authorised by ŠKODA AUTO A. S. ŠKODA AUTO A. S. does not guarantee or accept any liability with respect to the correctness of information in this document. Copyright by ŠKODA AUTO A. S. ©

Vehicles as of MY 2009 (Facelift) - for carrying out the coding, the ⇒ Vehicle diagnostic tester on-line (network connection) must be connected.

- Connect the ⇒ Vehicle diagnostic tester.



- Select operating mode "Targeted fault-finding".
- Skip - Selected Functions/Components and then:
 - ◆ Body
 - ◆ Electrical system
 - ◆ 01 – Self-diagnosable systems
 - ◆ Onboard supply control unit
 - ◆ Operation
 - ◆ Coding, change

**Note**

- ◆ *If the daylight driving light is activated (vehicles as of MY 2009), in addition the function of the daylight driving light (depending on equipment) must be coded and the coding of other functions must be carried out see ⇒ Vehicle diagnostic tester*
- ◆ *Once the control unit has been coded, perform an adaptation ⇒ [page 188](#).*

2.1.3 Adapting the functions of the vehicle voltage control unit - J519-

On the vehicle voltage control unit - J519- the following functions can be adapted:

**Note**

The adaptability of the following functions depends on the equipment.

All vehicles:

- ◆ Adapt Coming Home Time
- ◆ Adapt Leaving Home Time
- ◆ Adapt visual acknowledgement when locking and unlocking
- ◆ Adapt acoustic acknowledgement when locking and unlocking
- ◆ Adapt sensitivity of interior monitoring
- ◆ Adapt sensitivity of vehicle inclination sender
- ◆ Adaptation of flash cycles for Convenience flashing
- ◆ Adapt key with radio remote control
- ◆ Adjust headlamp washer interval

Vehicles as of MY 2009 (Facelift) additionally:

**Note**

Vehicles up to MY 2008 - the following functions can be adapted via the Convenience system central control unit - J393- . This control unit is no longer fitted as of MY 2009, the vehicle voltage control unit - J519- takes over its functions.

- ◆ adapt automatic locking at 15 km/h
- ◆ adapt automatic unlocking when the ignition key is removed

ŠKODA

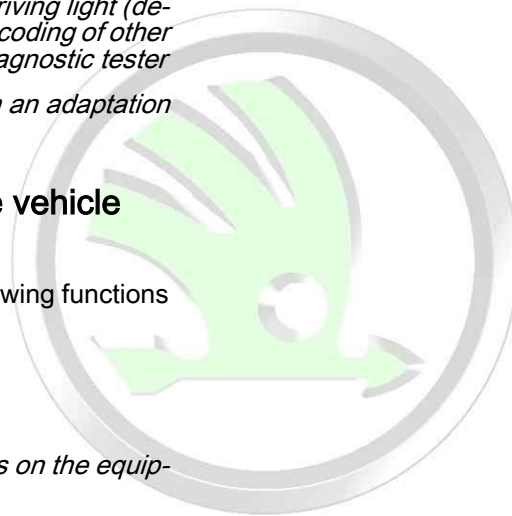

Protected by copyright. Copying for private or commercial purposes, in part or in whole, is not permitted unless authorised by ŠKODA AUTO A. S. ŠKODA AUTO A. S. does not guarantee or accept any liability with respect to the correctness of information in this document. Copyright by ŠKODA AUTO A. S. ©

- ◆ adapt individual door opening
- ◆ adapt Convenience activation via radio remote control
- ◆ adapt country specific coding of the sounders
- ◆ Deactivate factory mode

Adaptation process:

- Connect the ⇒ Vehicle diagnostic tester.
- Select operating mode “Targeted fault-finding”.
- Skip - Selected Functions/Components and then:
 - ◆ Body
 - ◆ Electrical system
 - ◆ 01 – Self-diagnosable systems
 - ◆ Onboard supply control unit
 - ◆ Operation

Subsequently select the function to be adapted.

2.1.4 Actuator diagnosis of the vehicle voltage control unit - J519-



Components which can be checked in the function “actuator diagnosis” are listed in the ⇒ Vehicle diagnostic tester.

Protected by copyright. Copying for private or commercial purposes, in part or in whole, is not permitted unless authorised by SKODA AUTO A. S. SKODA AUTO A. S. does not guarantee or accept any liability with respect to the correctness of information in this document. Copyright by SKODA AUTO A. S. ©

- Connect the ⇒ Vehicle diagnostic tester.
- Select operating mode “Targeted fault-finding”.
- Skip - Selected Functions/Components and then:
 - ◆ Body
 - ◆ Electrical system
 - ◆ 01 – Self-diagnosable systems
 - ◆ Onboard supply control unit
 - ◆ Operation
 - ◆ Final control diagnosis

2.2 Central control unit for convenience system - J393-

General description

The important functions of the central control unit for convenience system - J393- include:

- ◆ Sliding/tilting roof control (enable command)
- ◆ Window lifter control (enable command)
- ◆ Central locking control
- ◆ Anti-theft warning system control
- ◆ Tailgate locking

Some of the above mentioned functions can be adapted, see ⇒ [page 191](#) .

**Note**

- ◆ Further information and description of function ⇒ *Self-study programme No. 54 ; Škoda Octavia; Electrical Components .*
- ◆ After the installation, the new control unit must be coded with the ⇒ *Vehicle diagnostic tester and subsequently adapted ⇒ [page 191](#) .*
- ◆ The central control unit for convenience system - J393- is no longer fitted as of MY 2009 (Facelift). The vehicle voltage control unit - J519- takes over its functions.

Fault recognition and fault display

The central control unit for convenience system - J393- is equipped with self-diagnosis, which facilitates the fault finding.

For fault finding use the ⇒ *Vehicle diagnostic tester in the function "Targeted fault finding".*

⇒ ["2.2.1 Removing and installing the convenience system central control unit J393"](#) , [page 190](#)

⇒ ["2.2.2 Coding and adapting the central control unit for convenience system J393"](#) , [page 191](#)

2.2.1 Removing and installing the convenience system central control unit - J393-

Copying for private or commercial purposes, in part or in whole, is not permitted unless authorised by ŠKODA AUTO A. S. ŠKODA AUTO A. S. does not guarantee or accept any liability with respect to the correctness of information in this document. Copyright by ŠKODA AUTO A. S. ©

**Note**

The central control unit for convenience system - J393- is no longer fitted as of MY 2009 (Facelift). The vehicle voltage control unit - J519- takes over its functions.

Removing

- Switch off all electrical components and take out the ignition key.
- Remove the storage compartment in the dash panel on the front passenger side ⇒ *Body Work; Rep. gr. 70* .
- Release screws - 1 - (2 Nm).
- Remove bracket -3- with control unit -2-.
- Push the control unit out of the bracket -arrow-.
- Disconnect the plug -4- and subsequently remove.

Installing

Installation is carried out in the reverse order. When installing, observe the following:

**Note**

*After the installation, the new control unit must be coded with the ⇒ *Vehicle diagnostic tester and subsequently adapted ⇒ [page 191](#) .**

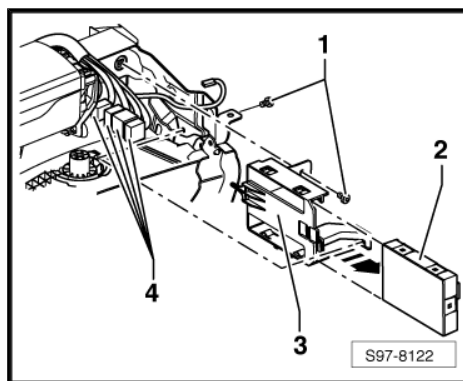

2.2.2 Coding and adapting the central control unit for convenience system - J393-



Note

The adaptability of the functions given in the ⇒ Vehicle diagnostic tester depends on the equipment.

- Connect the ⇒ Vehicle diagnostic tester.
- Select operating mode “Targeted fault-finding”.
- Skip - Selected Functions/Components and then:
 - ◆ Body
 - ◆ Electrical system
 - ◆ 01 – Self-diagnosable systems
 - ◆ Convenience system
 - ◆ Functions of the central control unit for convenience system

Select the function “Coding, change” (if the control unit was replaced).

After the coding, then select “Adaptation”.

2.3 Data bus diagnostic interface Gateway - J533-

⇒ [“2.3.1 General description”, page 191](#)

⇒ [“2.3.2 Removing and installing”, page 192](#)

⇒ [“2.3.3 Contact assignment data bus diagnostic interface Gateway J533”, page 193](#)

2.3.1 General description

Protected by copyright. Copying for private or commercial purposes, in part or in whole, is not permitted without the express and written consent of ŠKODA AUTO A. S. ŠKODA AUTO A. S. is not liable for any liability.

The data bus diagnostic interface Gateway - J533- serves to link different systems of the CAN data bus in the vehicle. It transmits data e.g. from the engine control unit (CAN bus drive) to the dash panel insert (dash panel insert CAN bus).

The data bus diagnostic interface Gateway - J533- is monitored by the self-diagnosis and can be tested with the ⇒ Vehicle diagnostic tester.

Check the databus activity - by doing this test you can notice if each databus (drive, comfort and infotainment) can switch over into the databus resting position (Sleep Mode).

Check the system at the databus - by doing this test the connection level of the data bus diagnostic interface to the other system can be checked for data bus.

Further information ⇒ Self-study programme No. 54 ; Škoda Octavia; Electrical Components .



2.3.2 Removing and installing



Note

- ◆ If the data bus diagnostic interface Gateway - J533- is replaced, it must be connected before the removal ⇒ Vehicle diagnostic tester and the function "replace data bus diagnostic interface" must be selected in the targeted fault finding for reading the codes stored in the control unit.
- ◆ If the original data bus diagnostic interface Gateway - J533- is not available or does not communicate with the diagnostic unit, then proceed according to the information in the ⇒ Vehicle diagnostic tester.
- ◆ The coding can also be performed on-line (network connection).

Remove - left-hand drive

The data bus diagnostic interface Gateway - J533- is located on the strut above the brake pedal.

- Switch off the ignition and all electrical consumers!
- Remove lower part of the dash panel insert on the driver's side ⇒ Body; Rep. gr. 70 Work.
- Unlock -arrows- control unit -1- and remove from control panel holder.
- Disconnect plug connection -2-.

Remove - right-hand drive

The data bus diagnostic interface Gateway - J533- is located above the onboard supply control unit - J519- at the rear.

- Removing the dash panel ⇒ Body Work; Rep. gr. 70 .
- Disconnect plug connection -3-.
- Press off the catch peg -arrow A- and push out -arrow B- the diagnostic interface -1- from the bracket -2-.

Installing

The installation occurs in reverse order.

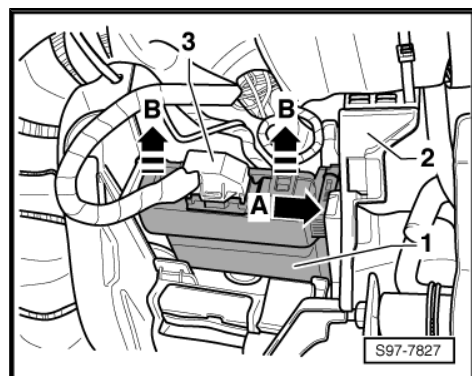
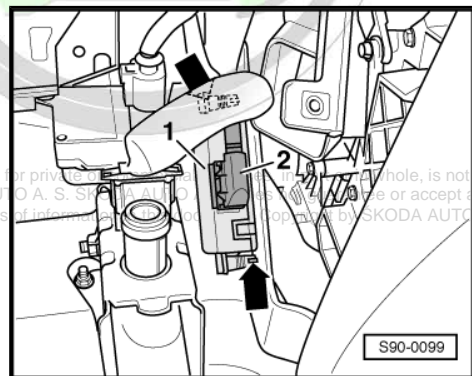

2.3.3 Contact assignment data bus diagnostic interface Gateway - J533-

- 1 - Battery "+" (terminal 30)
- 2 - Battery "+" (terminal 30) - as of CW 22.07 not assigned
- 3 - not assigned
- 4 - not assigned
- 5 - Convenience system CAN bus low
- 6 - Drive CAN bus Low
- 7 - not assigned
- 8 - Dash panel insert CAN bus Low
- 9 - Diagnosis CAN bus Low
- 10 - Infotainment CAN bus Low
- 11 - Earth "-" (terminal 31)
- 12 - Earth "-" (terminal 31) - as of CW 22/07 not assigned
- 13 - Dash panel insert time input
- 14 - Terminal 15
- 15 - Convenience system CAN bus high
- 16 - Drive CAN bus High
- 17 - not assigned
- 18 - Dash panel insert CAN bus High
- 19 - Diagnosis CAN bus High
- 20 - Infotainment CAN bus High

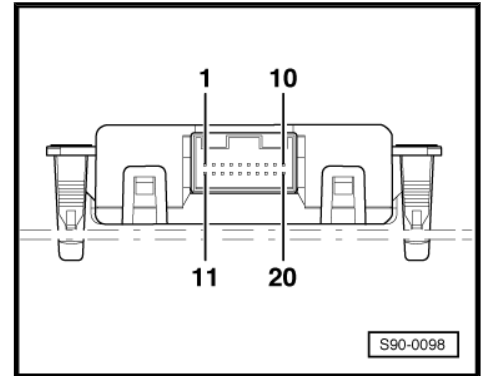

SKODA



Protected by copyright. Copying for private or commercial purposes, in part or in whole, is not permitted unless authorised by ŠKODA AUTO A. S. ŠKODA AUTO A. S. does not guarantee or accept any liability with respect to the correctness of information in this document. Copyright by ŠKODA AUTO A. S. ©



3 Vehicle diagnosis, testing and information systems

Following descriptions see Workshop Manual "Electrical System - General notes" ⇒ Electrical System - General notes; Rep. gr. 27 .

- ◆ Use and safety instructions
- ◆ Connect ⇒ Vehicle diagnostic tester

ŠKODA



Protected by copyright. Copying for private or commercial purposes, in part or in whole, is not permitted unless authorised by ŠKODA AUTO A. S. ŠKODA AUTO A. S. does not guarantee or accept any liability with respect to the correctness of information in this document. Copyright by ŠKODA AUTO A. S. ©

4 Wiring loom and plug repair, contact surface cleaning

All the notes and comments to the following chapters can be found in the Workshop Manual "Electrical System - General notes" ⇒ Electrical System - General notes; Rep. gr. 97 .

- ◆ General instructions for the repair on the vehicle electrics
- ◆ General instructions for wiring harness and plug repair
- ◆ Repair of airbag and belt tensioner cables
- ◆ Repair of CAN bus lines
- ◆ Use contact surface cleaning set - VAS 6410-

ŠKODA



Protected by copyright. Copying for private or commercial purposes, in part or in whole, is not permitted unless authorised by ŠKODA AUTO A. S. ŠKODA AUTO A. S. does not guarantee or accept any liability with respect to the correctness of information in this document. Copyright by ŠKODA AUTO A. S. ©